

Fault Protection Switch with Current Fold-back

Features

- ▶ Up to 100V input voltage protection
- ▶ Low on resistance – 4.0Ω typical
- ▶ Fast switching speed
- ▶ No external supplies needed

Applications

- ▶ Power supplies
- ▶ Fast resettable fuse
- ▶ High side switches
- ▶ Data acquisition

General Description

The Supertex FP0100 is a high voltage fault protection switch with current fold-back. It is designed to protect system output power supplies against over-current or short circuit conditions. In protection mode, the FP0100 limits the current to 300μA.

The FP0100 can be considered as a normally closed switch with a typical switch resistance of 4.0Ω. The peak current allowed to pass through the switch can be set by an external resistor across VOUT and RSEN. Once the voltage drop across VIN and VOUT exceeds a nominal value of 3.0V, the input current will fold-back to 300μA. In the off state, the FP0100 can withstand up to 100V. Higher input voltages can be accommodated by using an external depletion-mode MOSFET. Please refer to Figure 4 for more details. The FP0100 is available in a SOT-89 package.

Typical Application Circuit

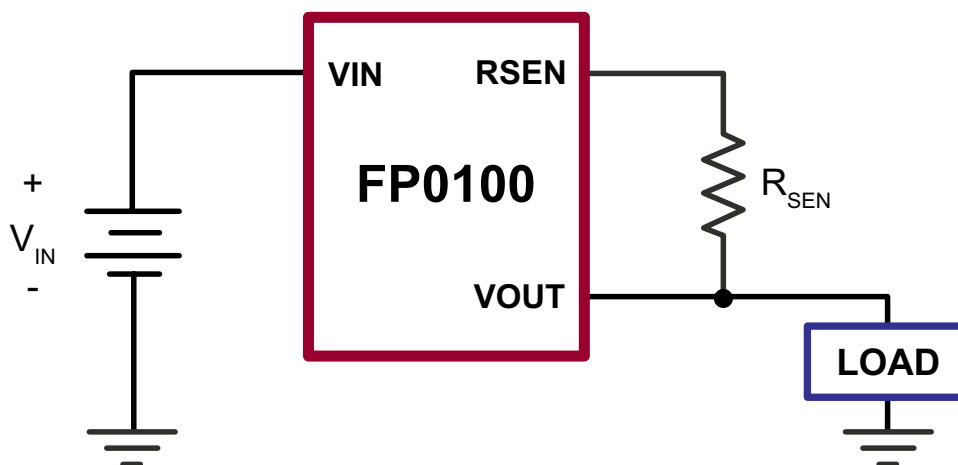

Ordering Information

Part Number	Package	Packing
FP0100N8-G	3-Lead SOT-89	2000/Reel

-G denotes a lead (Pb)-free / RoHS compliant package



Pin Configuration

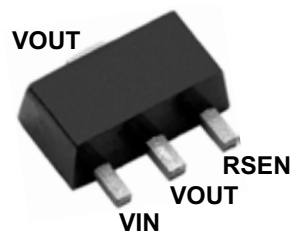

TO-243AA (SOT-89)

Absolute Maximum Ratings

Parameter	Value
$V_{IN} - V_{OUT}$, differential input voltage range	0 to +110V
Maximum junction temperature	+125°C
Storage temperature range	-65° to +150°C
Power dissipation, $T_A @ 25^\circ\text{C}$	1.6W ¹

Absolute Maximum Ratings are those values beyond which damage to the device may occur. Functional operation under these conditions is not implied. Continuous operation of the device at the absolute rating level may affect device reliability. All voltages are referenced to device ground.

Note:

1. Mounted on FR4 board, 25mm x 25mm x 1.57mm.

Product Marking



Y = Code for year sealed
W = Code for week sealed
— = "Green" Packaging

Package may or may not include the following marks: Si or

TO-243AA (SOT-89)

Typical Thermal Resistance

Package	θ_{ja}
3-Lead SOT-89	133°C/W

Electrical Characteristics ($T_A = 25^\circ\text{C}$ unless otherwise specified)

Sym	Parameter	Min	Typ	Max	Units	Conditions
$V_{IN} - V_{OUT}$	Differential input voltage range	0	-	100	V	$V_{OUT} = \text{GND}$, $I_{IN} = 600\mu\text{A}$
I_{PEAK}	Peak current	-	260	-	mA	$R_{SEN} = 0\Omega$
		-	20	40	mA	$R_{SEN} = 50\Omega$
		-	10	20	mA	$R_{SEN} = 100\Omega$
I_{OFF}	Off current	-	300	600	μA	$V_{IN} - V_{OUT} = 100\text{V}$, See I-V curve
R_{ON}	On resistance	-	4.0	6.0	Ω	$I_{IN} = 20\text{mA}$, $R_{SEN} = 0\Omega$
V_{TRIP}	$V_{IN - OUT}$ trip point to turn off	-	3.0	-	V	$R_{SEN} = 50\Omega$, $I_{IN} = 90\%$ of I_{PEAK} See I-V curve
V_{OFF}	Switch turn off voltage	-	-	4.5	V	$I_{OFF} \leq 600\mu\text{A}$
T_J	Operating junction temperature	-40	-	+125	°C	---

Block Diagram

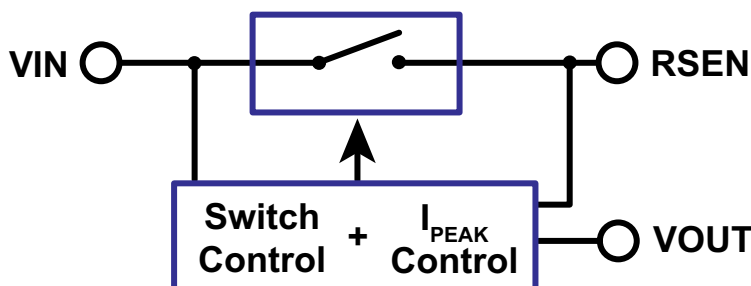

Figure 1. Typical I-V Characteristics

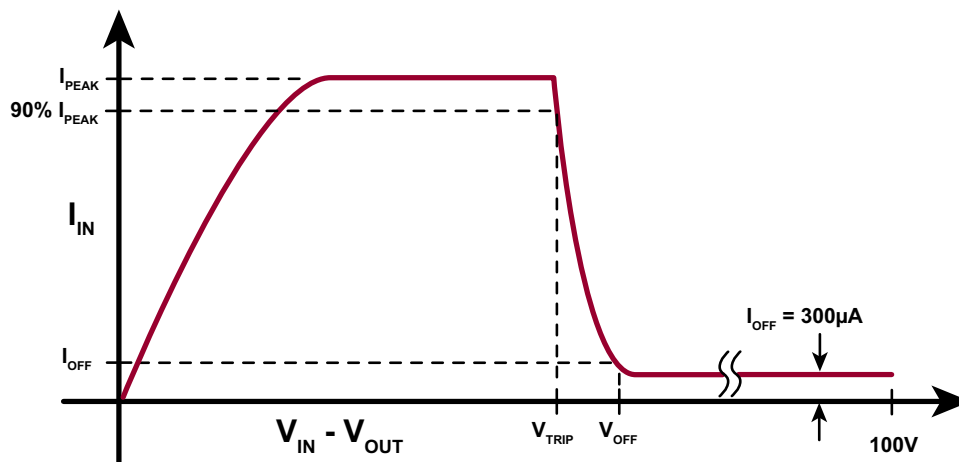
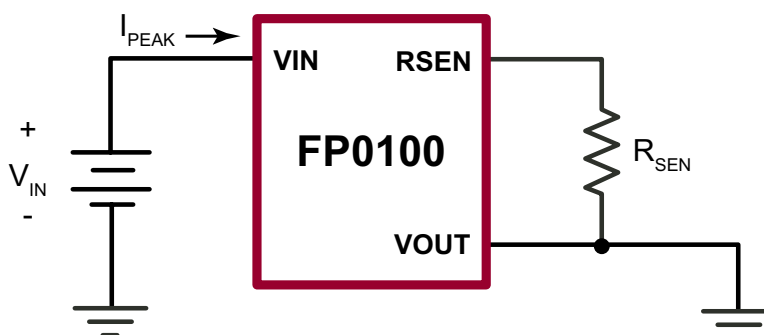

Figure 2. Test Circuit for I_{PEAK} vs R_{SEN}



The input peak current, I_{PEAK} , can be lowered by adding an external resistor across the RSEN and VOUT pins as shown in the test circuit in Figure 2. I_{PEAK} will decrease as the resist-

or value of R_{SEN} increases. The typical I_{PEAK} vs R_{SEN} characteristic is shown in Figure 3.

Figure 3. Typical I_{PEAK} vs R_{SEN} Characteristic

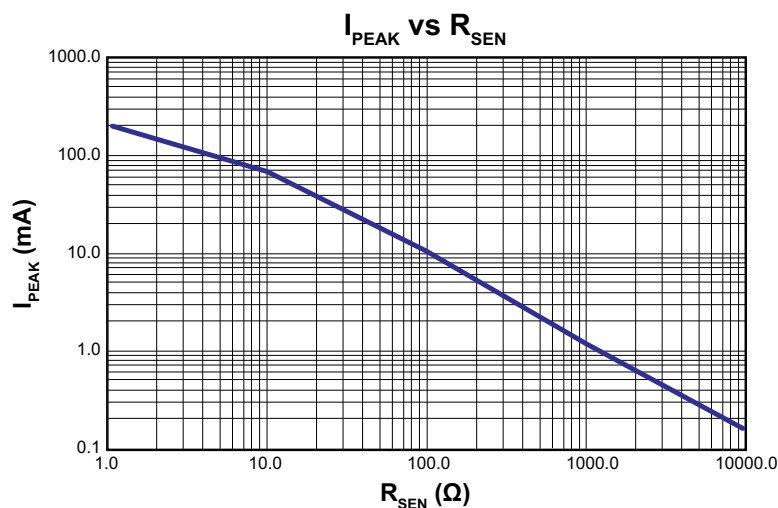

Figure 4. Higher Input Voltage Application

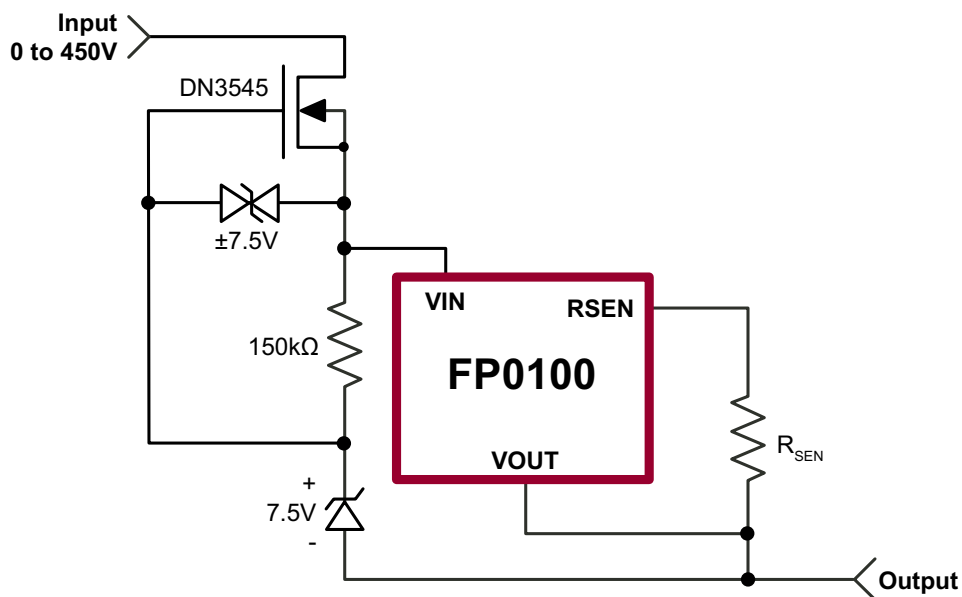
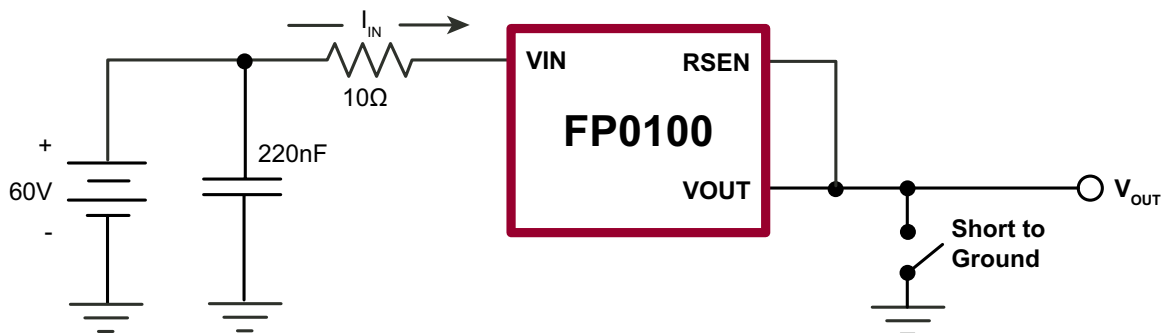

Figure 5. Short Circuit Test Performance



The FP0100 has a typical response time of less than 30ns. The short circuit test set-up is shown in Figure 5. The output is at 60V prior to a short. A 10Ω resistor is used to measure the current going into the FP0100. A 220nF ceramic capacitor is added on the input to supply any transient currents that

might occur. The waveform is shown in Figure 6. Channel 1 is the output voltage which is discharged to 0V. Channel 2 is the voltage across the 10Ω resistor. The input current peaks to 400mA then decays quickly within 20ns.

Figure 6. Typical Short Circuit Waveforms

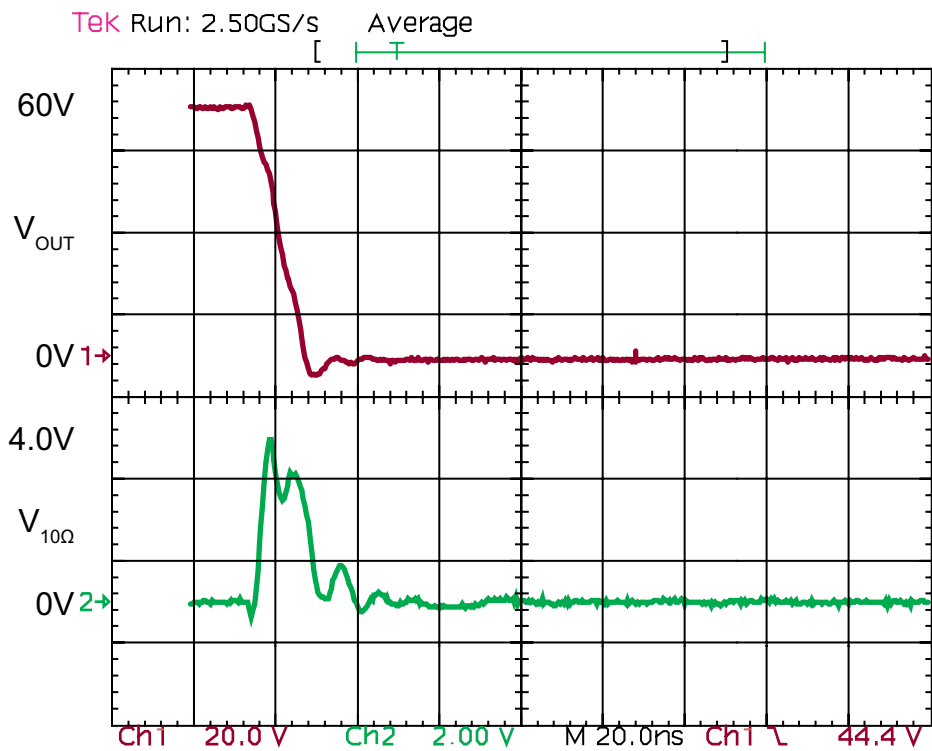

Pin Description

Pin #	Pin Name	Description
1	VIN	Input voltage
2, 4	VOUT	Output voltage
3	RSEN	Current sense for I_{PEAK} control. Connects to an external resistor across the RSEN and VOUT pins to set the I_{PEAK} .

3-Lead TO-243AA (SOT-89) Package Outline (N8)

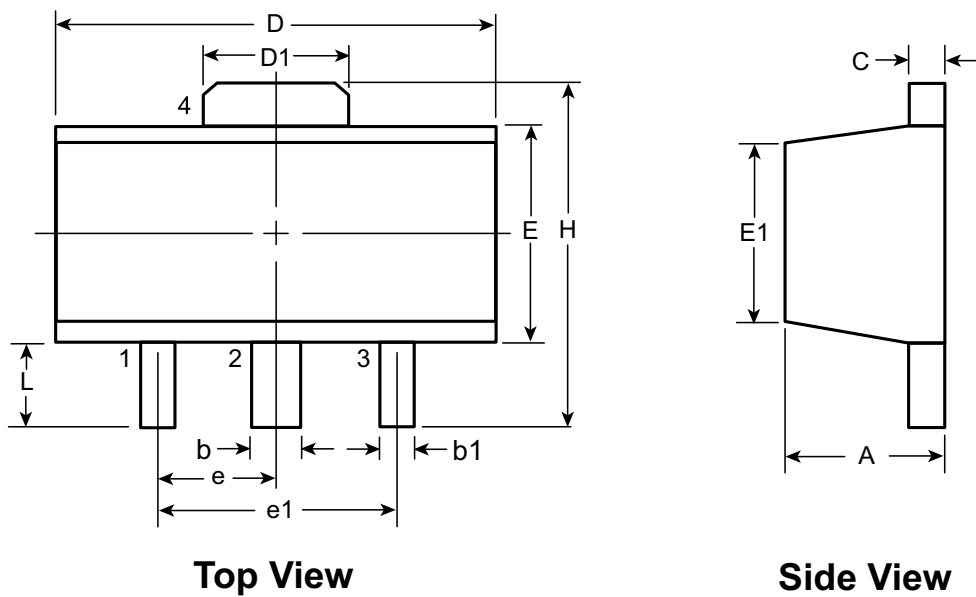

Top View

Side View

Symbol		A	b	b1	C	D	D1	E	E1	e	e1	H	L		
Dimensions (mm)	MIN	1.40	0.44	0.36	0.35	4.40	1.62	2.29	2.00†	1.50 BSC	3.00 BSC	3.94	0.73†		
	NOM	-	-	-	-	-	-	-	-			-	-	-	-
	MAX	1.60	0.56	0.48	0.44	4.60	1.83	2.60	2.29			4.25	1.20		

JEDEC Registration TO-243, Variation AA, Issue C, July 1986.

† This dimension differs from the JEDEC drawing

Drawings not to scale.

Supertex Doc. #: DSPD-3TO243AAN8, Version F111010.

(The package drawing(s) in this data sheet may not reflect the most current specifications. For the latest package outline information go to <http://www.supertex.com/packaging.html>.)

Supertex inc. does not recommend the use of its products in life support applications, and will not knowingly sell them for use in such applications unless it receives an adequate "product liability indemnification insurance agreement." Supertex inc. does not assume responsibility for use of devices described, and limits its liability to the replacement of the devices determined defective due to workmanship. No responsibility is assumed for possible omissions and inaccuracies. Circuitry and specifications are subject to change without notice. For the latest product specifications refer to the Supertex inc. (website: <http://www.supertex.com>)

X-ON Electronics

Largest Supplier of Electrical and Electronic Components

Click to view similar products for [Power Switch ICs - Power Distribution category](#):

Click to view products by [Supertex manufacturer](#):

Other Similar products are found below :

[TCK111G,LF\(S\)](#) [FPF1018](#) [DS1222](#) [TCK2065G,LF](#) [SZNCP3712ASNT3G](#) [MIC2033-05BYMT-T5](#) [MIC2033-12AYMT-T5](#) [MIC2033-05BYM6-T5](#) [SLG5NT1437VTR](#) [SZNCP3712ASNT1G](#) [DML1008LDS-7](#) [KTS1670EDA-TR](#) [KTS1640QGDV-TR](#) [KTS1641QGDV-TR](#) [U6513A](#) [MIC2012YM-TR](#) [MP5095GJ-P](#) [TPS2021IDRQ1](#) [TPS2104DBVR](#) [TPS22958NDGKR](#) [MIC2098-1YMT-TR](#) [MIC94062YMT TR](#) [MP6231DN-LF](#) [MIC2015-1.2YM6 TR](#) [MIC2075-2YM](#) [MIC94068YML-TR](#) [SIP32461DB-T2-GE1](#) [NCP335FCT2G](#) [TCK105G,LF\(S\)](#) [AP2411S-13](#) [AP2151DSG-13](#) [AP2172MPG-13](#) [MIC94094YC6-TR](#) [MIC94093YC6-TR](#) [MIC94064YC6-TR](#) [MIC94061YMT-TR](#) [MIC2505-1YM](#) [MIC94085YFT-TR](#) [MIC94042YFL-TR](#) [MIC2005-1.2YM6-TR](#) [NCP333FCT2G](#) [NCP331SNT1G](#) [TPS2092DR](#) [TPS2063DR](#) [MIC2008YML-TR](#) [MIC94084YFT-TR](#) [MIC2040-1YMM](#) [DIO1280WL12](#) [AP22814ASN-7](#) [MIC2043-2YTS](#)