

High Voltage, Low Noise, Inductorless EL Lamp Driver

Features

- ▶ No external components required when using an external EL clock frequency
- ▶ EL frequency can be set by an external resistor
- ▶ Low noise
- ▶ DC to AC converter
- ▶ Drives up to 5.0nF load (approx. 1.5in² lamp)
- ▶ Output voltage regulation
- ▶ Enable function
- ▶ EL Lamp dimming

Applications

- ▶ Cell phone keypads and displays
- ▶ Transceivers
- ▶ MP3 players
- ▶ Watches
- ▶ Pagers
- ▶ Measuring instruments/gauges

General Description

The Supertex HV850 is a high voltage electroluminescent (EL) Lamp Driver IC. It is designed to drive EL lamps of up to 1.5in², with capacitive values up to 5.0nF. The HV850 converts a low voltage DC input to a high voltage AC output across an EL lamp. It uses a charge pump scheme to boost the input voltage, eliminating the need for external inductors, diodes, and high voltage capacitors, components commonly found in conventional topologies.

The charge pump circuit discharges its energy into an EL lamp through a high voltage H-bridge. Once the voltage reaches its regulated limit, it is turned off to conserve power. The EL lamp is then discharged to ground and the H-bridge changes state to allow the charge pump to charge the EL lamp in the opposite direction.

The EL lamp frequency can be set either by an external resistor, R_{EL} , or by applying an external clock, where the clock frequency is divided by 128 to set the EL lamp frequency.

Typical Application Circuits *(For $V_{DD} = 3.4V$ to $4.2V$ only)*

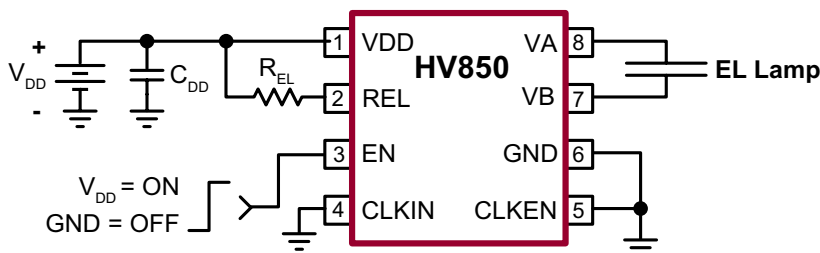
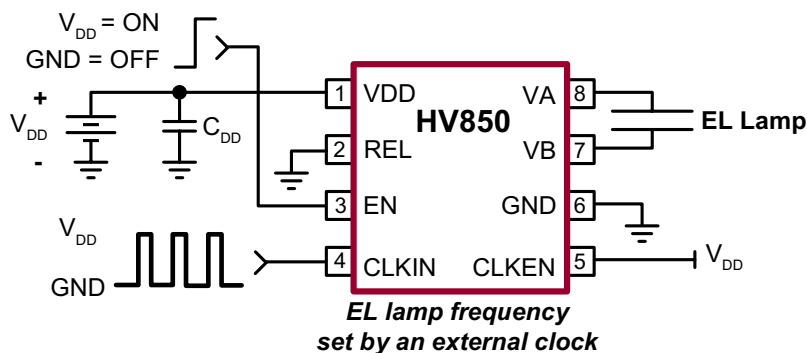

Ordering Information

Device	Package Options
	8-Lead MSOP 3.00x3.00mm body 1.10mm height (max) 0.65mm pitch
HV850	HV850MG-G

-G indicates package is RoHS compliant ("Green")



Absolute Maximum Ratings

Parameter	Value
V _{DD} , supply voltage	-0.5V to 4.5V
Operating temperature	-25°C to +85°C
Storage temperature	-65°C to +150°C
Power dissipation	300mW

Stresses beyond those listed under "Absolute Maximum Ratings" may cause permanent damage to the device. These are stress ratings only, and functional operation of the device at these or any other conditions beyond those indicated in the operational sections of the specifications is not implied. Exposure to absolute maximum rating conditions for extended periods may affect device reliability.

Recommended Operating Conditions

Sym	Parameter	Min	Typ	Max	Units	Conditions
V _{DD}	Input voltage	3.0	-	4.2	V	---
f _{EL}	EL lamp frequency	50	-	500	Hz	---
C _{LOAD}	EL lamp capacitance	0	-	5.0	nF	---
T _A	Operating temperature	-25	-	+85	°C	---

Electrical Characteristics (Unless otherwise specified V_{DD} = 3.5V, T_A = 25°C)

Sym	Parameter	Min	Typ	Max	Units	Conditions
I _{DDQ}	Quiescent current	-	-	150	nA	EN = 0V
V _A or V _B	Peak output voltage	63	70	77	V	No load.
V _A - V _B	Peak to peak output voltage	126	140	154	V	
f _{EL}	EL lamp frequency	225	250	275	Hz	R _{EL} = 1.65MΩ or CLK = 32kHz
I _{DD}	Operating current	-	-	16	mA	See Figure 1, V _{DD} = 3.5V, R _{EL} = 1.5MΩ, Load = 3.3nF + 1.0kΩ
V _A or V _B	Peak output voltage	54	-	74	V	
V _A - V _B	Peak to peak output voltage	108	-	148	V	
f _{EL}	EL lamp frequency	250	294	338	Hz	
t _{ROUT}	Output voltage rise time	1.5	-	-	ms	f _{EL} = 250Hz, 1in ² lamp, 10 to 90% of final value

Pin Configuration

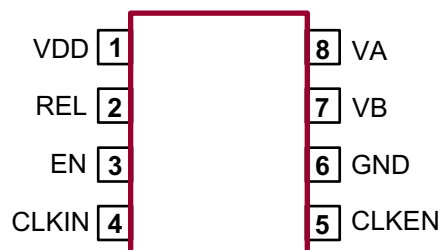

8-Lead MSOP (MG)
(top view)

Product Marking

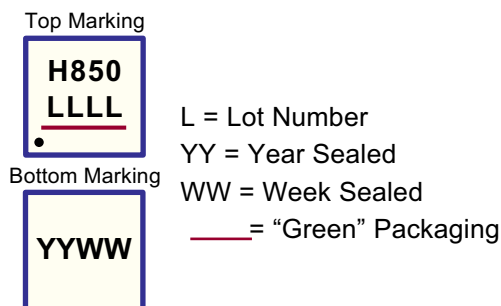

Package may or may not include the following marks: Si or

8-Lead MSOP (MG)

Logic Inputs (Unless otherwise specified $V_{DD} = 3.5V, T_A = 25^\circ C$)

Sym	Parameter	Min	Typ	Max	Units	Conditions
V_{IL}	Input logic low voltage	0	-	0.5	V	---
V_{IH}	Input logic high voltage	2.0	-	V_{DD}	V	---
I_{IL}	Input logic low current	-	-	1.0	μA	---
I_{IH}	Input logic high current	-	-	1.0	μA	---
EN_{RISE}	Enable input rise time (for delay turn on)	0.01	-	10	ms	Using external R-C circuit, see Figure 2.
EN_{FALL}	Enable input fall time (for delay turn off)	10 μ	-	5.0	s	
C_{IN}	Logic input capacitance	-	-	10	pF	---

Block Diagram

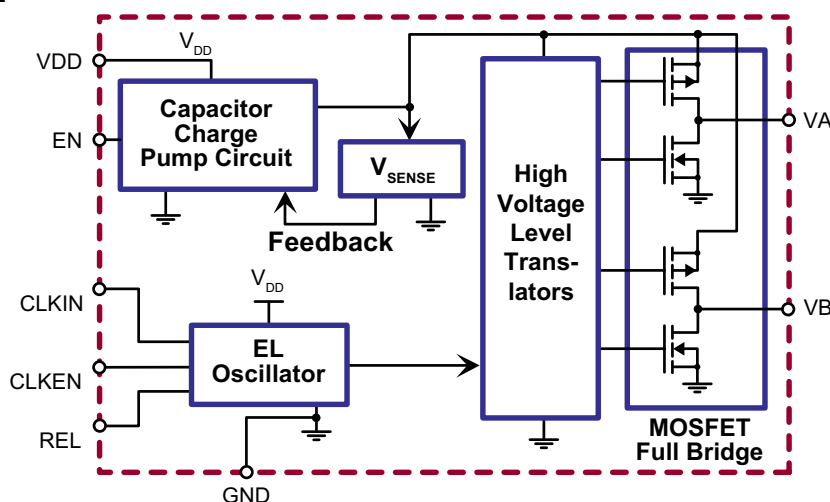
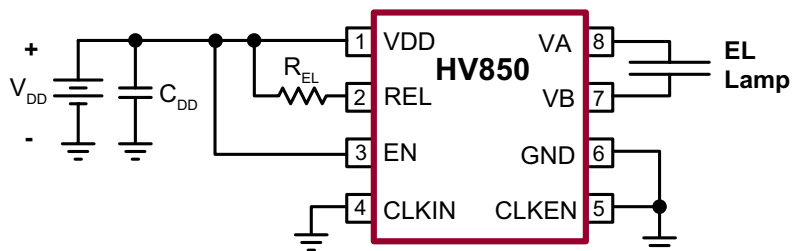

Figure 1: Typical Application Circuit (without Enable function)



Load	R_{EL} (M Ω)	V_{DD} (V)	I_{DD} (mA)	Peak V_A (V)	f_{EL} (Hz)
3.3nF + 1.0k Ω	1.5	3.0	8.9	53	294
		3.5	10.2	61	
		4.0	10.4	66	

Note: $C_{DD} = 2.2\mu F, 6.3V$ low ESR

Typical Performance

Lamp Size (in ²)	R _{EL} (MΩ)	V _{DD} (V)	I _{DD} (mA)	Peak V _A (V)	f _{EL} (Hz)	Brightness (cd/m ²)
1.0	1.65	3.0	8.4	53	250	7.31
		3.5	9.4	62		10.35
		4.0	9.9	66		12.62
0.5	2.0	3.0	5.5	62	210	11.54
		3.5	5.3	68		14.33
		4.0	4.9	68		14.90
1.0	3.3	3.0	5.6	62	128	8.55
		3.5	5.4	67		10.29
		4.0	5.0	68		10.94
0.5	3.3	3.0	4.6	64	128	8.25
		3.5	4.1	68		9.62
		4.0	3.8	68		9.95
1.0	4.7	3.0	4.8	64	89	6.02
		3.5	4.4	68		7.5
		4.0	5.0	68		10.94

Typical Output Waveform

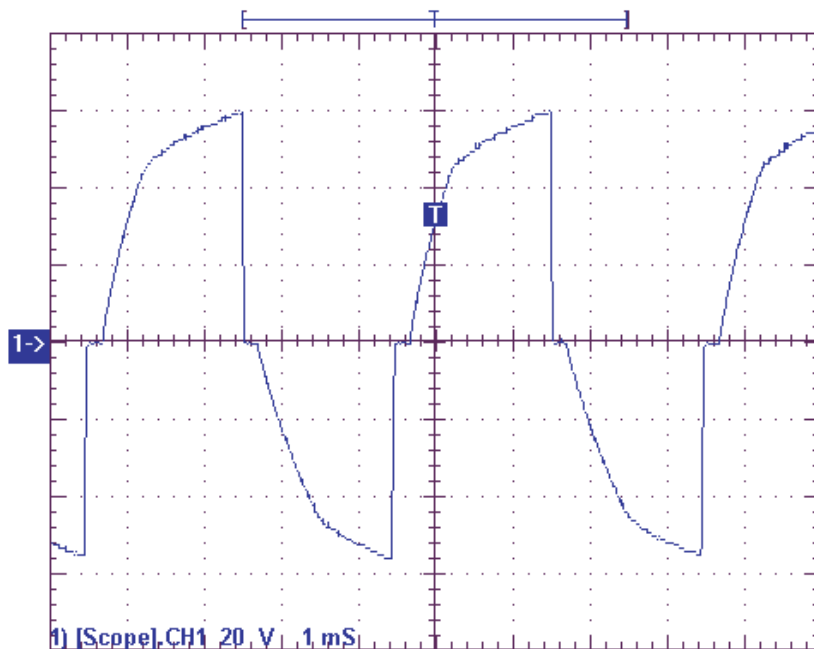

V_{DD} = 3.5V, f_{EL} = 250.0Hz; Load = 3.3nF+1.0kΩ; I_{DD} = 9.19mA, CH1 20V/div, 1.0mS/div

Figure 2: Push Button Turn on with Delay Turn off (For $V_{DD} = 3.4V$ to $4.2V$ only)

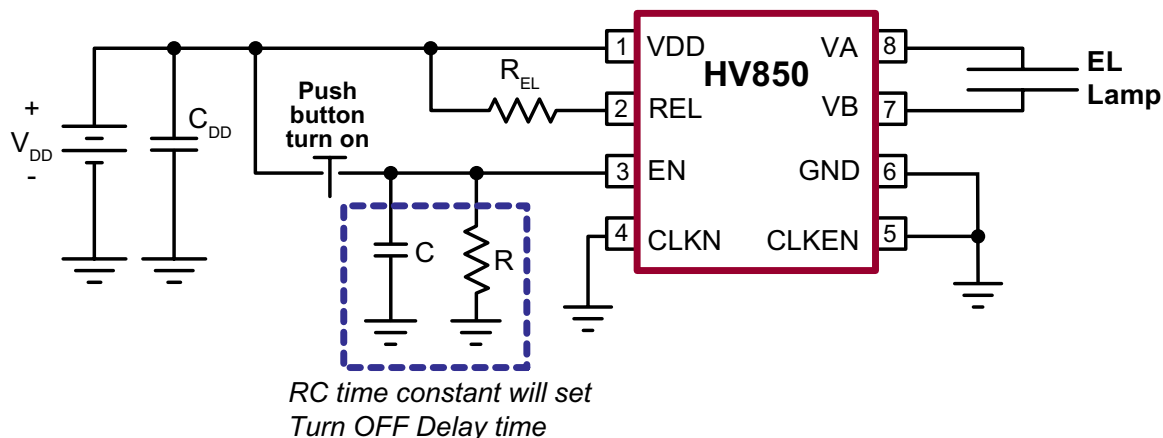
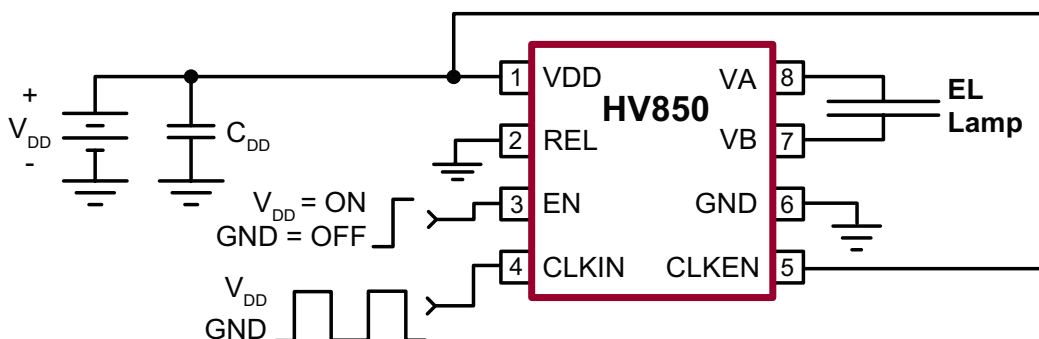

Figure 3: Independent Programmable Output Frequency (f_{EL}) (For $V_{DD} = 3.4V$ to $4.2V$ only)



EL Lamp Dimming Using PWM

EL lamp dimming can be achieved by applying a PWM signal to the ENABLE pin. The PWM signal duty cycle is proportional to the lamp brightness. This is done by pulse skipping the output pulses. The PWM frequency should be kept below the EL frequency but above 50Hz to avoid flickering.

Figure 4: PWM Dimming Circuit (For $V_{DD} = 3.4V$ to $4.2V$ only)

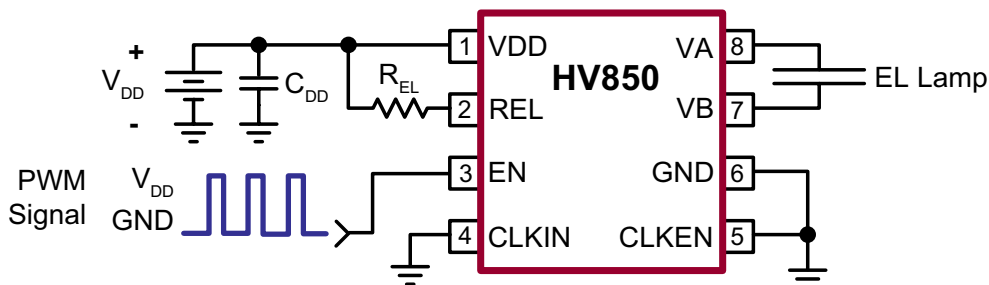

Pin Description

Pin #	Pad	Description
1	VDD	Input supply voltage pin.
2	REL	An external resistor to VDD will set the EL lamp frequency. The EL lamp frequency is inversely proportional to the resistor value.
3	EN	Enable input pin. Logic high will turn the device ON. An external R-C circuit can be added for a delayed turn off. Logic low will turn the device OFF only for $V_{DD} = 3.4V$ to $4.2V$. For V_{DD} lower than $3.4V$, logic low will not turn the device OFF.
4	CLKIN	Logic input pin. An external logic clock applied to this pin can be used to set the EL lamp frequency (see Figure 3). This is useful for applications requiring the EL lamp to be synchronized to a system clock. Connect to ground when not in use.
5	CLKEN	Logic input pin. Logic high will cause the EL lamp frequency to be set by the CLKIN input. Logic low will cause the EL lamp frequency to be set by the external R_{EL} resistor.
6	GND	IC ground pin.
7	VB	EL lamp driver output pin. The EL lamp is connected across VA and VB terminals.
8	VA	EL lamp driver output pin. The EL lamp is connected across VA and VB terminals.

8-Lead MSOP Package Outline (MG)

3.00x3.00mm body, 1.10mm height (max), 0.65mm pitch

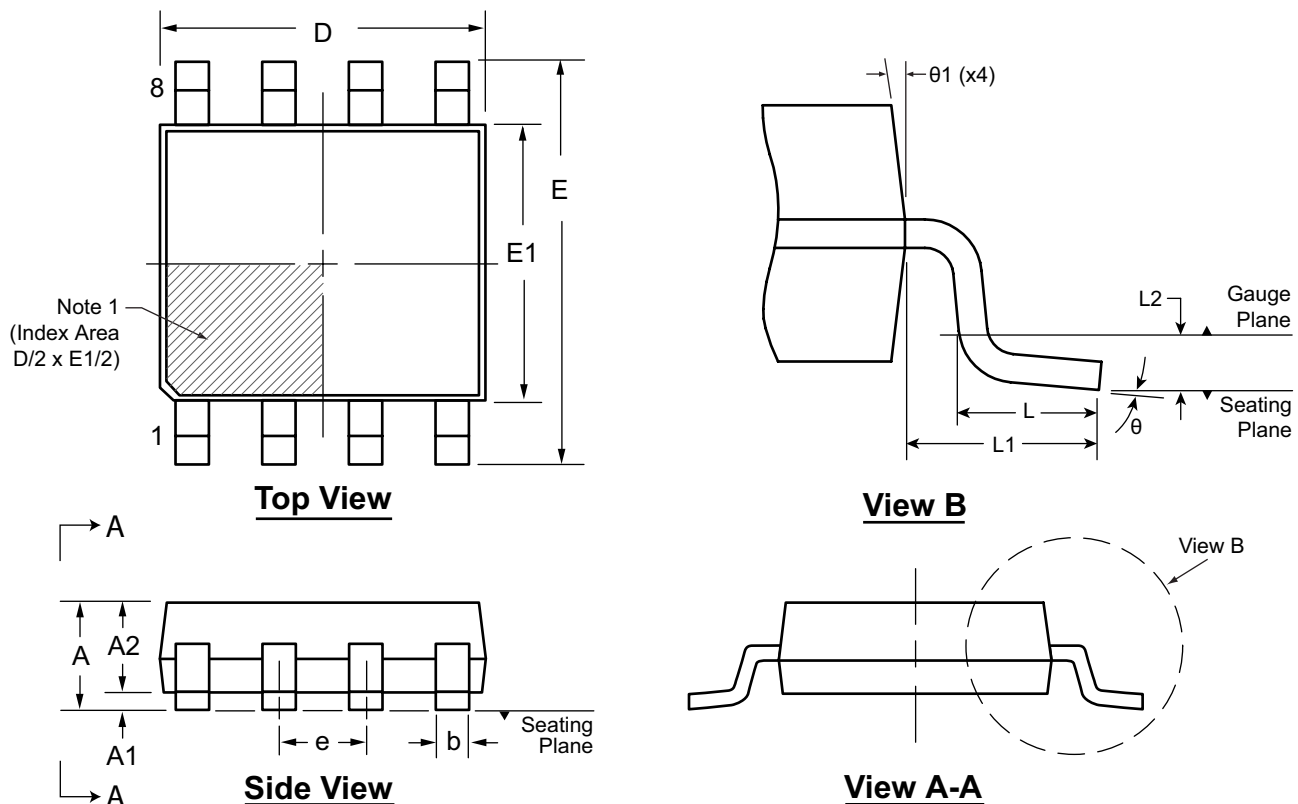

Note:
 1. A Pin 1 identifier must be located in the index area indicated. The Pin 1 identifier can be: a molded mark/identifier; an embedded metal marker; or a printed indicator.

Symbol	A	A1	A2	b	D	E	E1	e	L	L1	L2	θ	θ1	
Dimension (mm)	MIN	0.75*	0.00	0.75	0.22	2.80*	4.65*	2.80*	0.65 BSC	0.40	0.95 REF	0.25 BSC	0°	5°
	NOM	-	-	0.85	-	3.00	4.90	3.00		0.60		0.25	-	-
	MAX	1.10	0.15	0.95	0.38	3.20*	5.15*	3.20*		0.80		0.25	8°	15°

JEDEC Registration MO-187, Variation AA, Issue E, Dec. 2004.

* This dimension is not specified in the JEDEC drawing.

Drawings are not to scale.

Supertex Doc. #: DSPD-8MSOPMG, Version H041309.

(The package drawing(s) in this data sheet may not reflect the most current specifications. For the latest package outline information go to <http://www.supertex.com/packaging.html>.)

Supertex inc. does not recommend the use of its products in life support applications, and will not knowingly sell them for use in such applications unless it receives an adequate "product liability indemnification insurance agreement." Supertex inc. does not assume responsibility for use of devices described, and limits its liability to the replacement of the devices determined defective due to workmanship. No responsibility is assumed for possible omissions and inaccuracies. Circuitry and specifications are subject to change without notice. For the latest product specifications refer to the Supertex inc. (website: <http://www.supertex.com>)

X-ON Electronics

Largest Supplier of Electrical and Electronic Components

Click to view similar products for [Display Drivers & Controllers](#) category:

Click to view products by [Supertex](#) manufacturer:

Other Similar products are found below :

[ICB2FL01G](#) [HV5812PJ-G-M904](#) [TW8813-LB2-GR](#) [TW8811-PC2-GR](#) [MAX1839EEP+](#) [TW9907-TA1-GR](#) [LX27901IDW](#) [SSD2828QN4](#)
[ICB2FL01GXUMA2](#) [DLP2000FQC](#) [PAD1000YFFR](#) [S1D13746F01A600](#) [FIN324CMLX](#) [AD8387JSVZ](#) [DLPC6421ZPC](#) [HV852K7-G](#)
[HV859K7-G](#) [HV857K7-G](#) [DIO2133CT14](#) [S1D13506F00A200](#) [S1D13L03F00A100-40](#) [TW2836-BA1-GR](#) [SSD2829QL9](#) [MAX749CSA+T](#)
[MAX4820EUP+T](#) [ICL7135CAI+](#) [ICL7135CMH+D](#) [ICL7137CMH+D](#) [MAX25221BATJ/V+](#) [S1D13748B00B100](#) [S1D13A05B00B200](#)
[MAX3738ETG+T](#) [MAX8722CEEG+](#) [MAX749CPA+](#) [MAX8785AETI+](#) [ICL7135CQI+](#) [HV518PJ-G-M903](#) [HV5812P-G](#) [HV5812PJ-G](#)
[HV7224PG-G](#) [HV853K7-G](#) [HV860K7-G](#) [HV6810WG-G](#) [HV823LG-G](#) [HV857MG-G](#) [HV833MG-G](#) [HV857LMG-G](#) [HV859MG-G](#)
[FMS6363ACSX](#) [FMS6364AMTC14X](#)