

LED Driver IC with Average-Mode Constant Current Control

Features

- Fast Average Current Control
- Correction for Propagation Delay and Offset Voltage
- Fixed Offtime Switching Mode
- Linear Dimming Input
- PWM Dimming Input
- Output Short-Circuit Protection with Programmable Skip Mode
- Input Undervoltage Shutdown

Applications

- Backlighting of LCD Panels
- General Lighting

General Description

The HV9803 is an open-loop, Average-mode current control LED driver IC operating in a constant Offtime mode. The IC features $\pm 2\%$ current accuracy and tight line and load regulation of the LED current without any need for loop compensation or high-side current sensing. Its auto-zero circuit cancels the effect of both the input offset voltage and the propagation delay in the current sense comparator.

The HV9803 can be powered from a 7V to 13.2V supply. The IC features fast PWM dimming response. The linear dimming input LD can accept a reference voltage of up to 2.5V.

The IC is equipped with a current limit comparator for Hiccup-mode output short-circuit protection. It also features a programmable input undervoltage shutdown.

Package Type

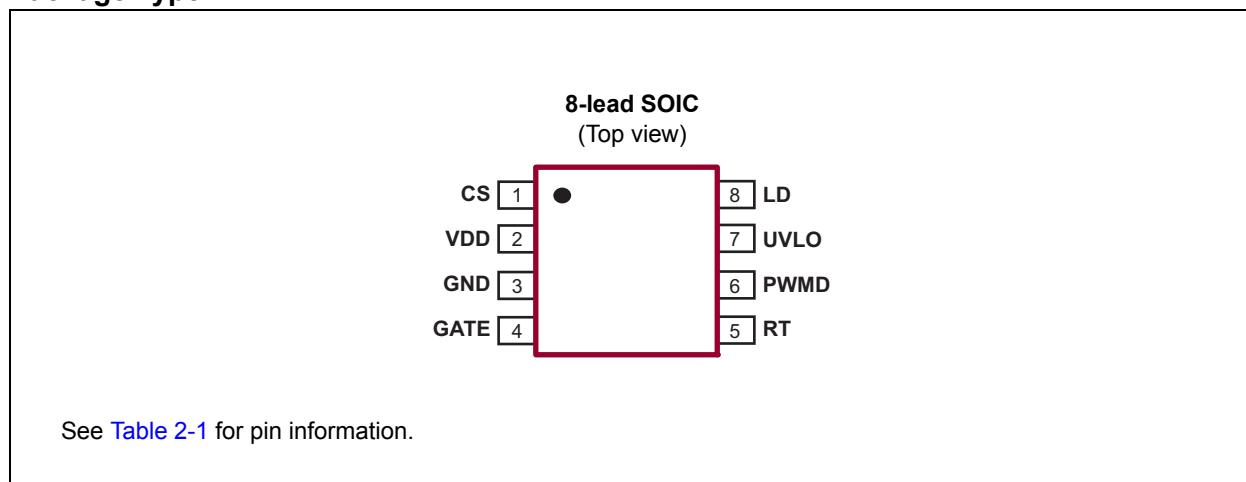

HV9803

Functional Block Diagram

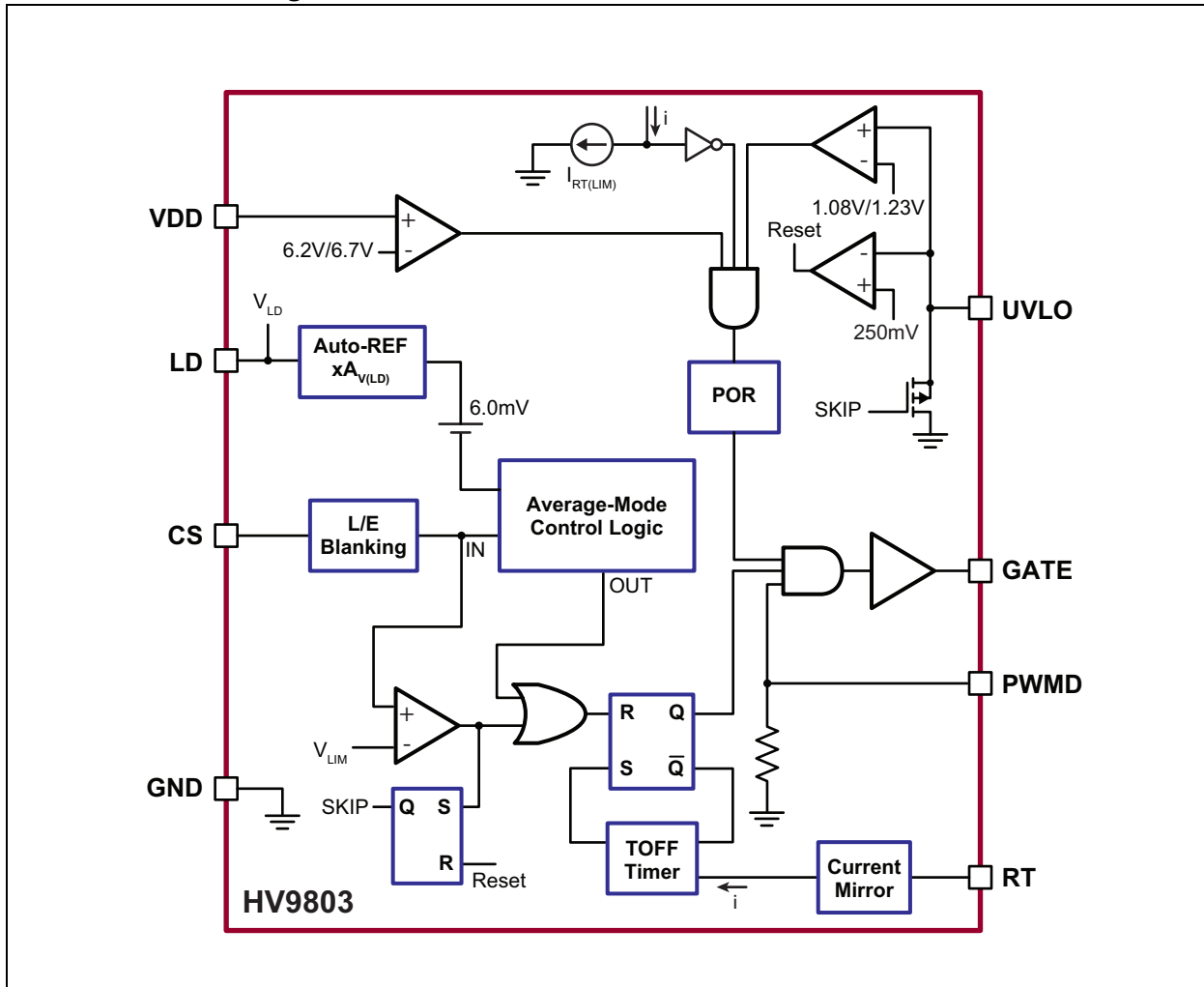

Typical Application Circuit

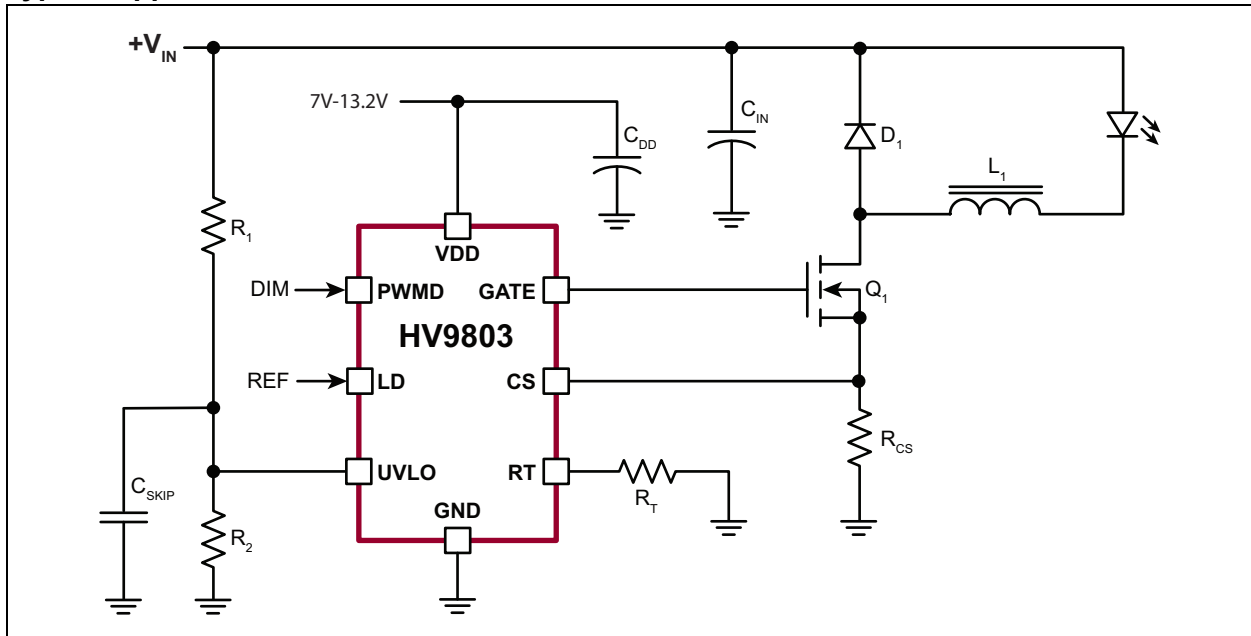

HV9803

1.0 ELECTRICAL CHARACTERISTICS

Absolute Maximum Ratings†

V_{DD} , GATE, CS	-0.3V to +14V
LD, RT, PWMD, UVLO	-0.3V to +6V
Junction Temperature, T_J	-40°C to +150°C
Storage Temperature, T_S	-65°C to +150°C
Power Dissipation (at 25 °C):	
8-lead SOIC	650 mW

† **Notice:** Stresses above those listed under “Absolute Maximum Ratings” may cause permanent damage to the device. This is a stress rating only, and functional operation of the device at those or any other conditions above those indicated in the operational sections of this specification is not intended. Exposure to maximum rating conditions for extended periods may affect device reliability.

DC ELECTRICAL CHARACTERISTICS

Electrical Specifications: Specifications apply over the full operating ambient temperature range, $T_A = -40^\circ\text{C}$ to $+125^\circ\text{C}$. Unless otherwise noted, $T_A = 25^\circ\text{C}$, $V_{DD} = 12\text{V}$ and $V_{PWMD} = 5\text{V}$.

Parameter	Sym.	Min.	Typ.	Max	Unit	Conditions
INPUT						
Input DC Supply Voltage Range	V_{DD}	—	—	13.2	V	DC input voltage
Quiescent V_{DD} Supply Current	I_{DD}	—	1.5	2.5	mA	$V_{CS} = 0\text{V}$
V_{DD} UNDERVOLTAGE LOCKOUT						
V_{DD} Undervoltage Lockout Upper Threshold	$V_{DDUV,R}$	6.45	6.7	6.95	V	V_{DD} Rising
V_{DD} Undervoltage Lockout Hysteresis	ΔV_{DDUV}	—	500	—	mV	V_{DD} Falling
PWM DIMMING						
PWMD Input Low Voltage	$V_{PWMD(LO)}$	—	—	1	V	
PWMD Input High Voltage	$V_{PWMD(HI)}$	2.6	—	—	V	
Internal Pull-Down Resistance at PWMD	R_{PWMD}	50	100	150	k Ω	
CURRENT SENSE COMPARATOR						
External Reference Voltage	V_{LD}	0	—	3	V	
CS Threshold Voltage	V_{CST}	762	778	794	mV	$V_{LD} = 1.6\text{V}$
		955	975	995		$V_{LD} = 2\text{V}$
LD to CS Voltage Ratio	$A_{V(LD)}$	—	0.49	—	—	
Current Sense Blanking Interval	T_{BLANK}	150	—	280	ns	
Minimum On-Time	$T_{ON(MIN)}$	—	—	760	ns	$V_{CS} = 0.5 V_{LD} + 30\text{ mV}$
Maximum Steady State Duty Cycle	D_{MAX}	80	—	—	%	Reduction in output LED current may occur beyond this duty cycle.
SHORT-CIRCUIT PROTECTION						
Current Limit Threshold Voltage	V_{LIM}	1.57	1.75	1.93	V	
Current Limit Delay CS-to-GATE	T_{DELAY}	—	—	150	ns	$V_{CS} = V_{LIM} + 30\text{ mV}$
UVLO Skip Timer Reset Switch Resistance	R_{UVRST}	—	—	500	Ω	

DC ELECTRICAL CHARACTERISTICS (CONTINUED)

Electrical Specifications: Specifications apply over the full operating ambient temperature range, $T_A = -40^\circ\text{C}$ to $+125^\circ\text{C}$. Unless otherwise noted, $T_A = 25^\circ\text{C}$, $V_{DD} = 12\text{V}$ and $V_{PWMD} = 5\text{V}$.

Parameter	Sym.	Min.	Typ.	Max.	Unit	Conditions
UVLO Skip Timer Reset Voltage	V_{UVRST}	200	—	300	mV	
Minimum On-Time (Short Circuit)	$T_{ON(MIN)}$	—	—	430	ns	$V_{CS} = V_{LIM} + 30\text{ mV}$
T_{OFF} TIMER						
Offtime	T_{OFF}	6.7	9	11.3	μs	$R_T = 250\text{ k}\Omega$
		0.8	1	1.2	μs	$R_T = 25\text{ k}\Omega$
RT Overcurrent Threshold	$I_{RT(LIM)}$	—	2.8	—	mA	
GATE DRIVER						
Gate Sourcing Current	I_{SOURCE}	0.165	—	—	A	$V_{GATE} = 0\text{V}$
Gate Sinking Current	I_{SINK}	0.165	—	—	A	$V_{GATE} = V_{DD}$
GATE Output Rise Time	t_{RISE}	—	30	50	ns	$C_{GATE} = 500\text{ pF}$
GATE Output Fall Time	t_{FALL}	—	30	50	ns	$C_{GATE} = 500\text{ pF}$
UVLO						
Undervoltage Upper Threshold Voltage	$V_{UVLO,R}$	1.17	1.23	1.29	V	V_{UVLO} rising
Undervoltage Threshold Voltage Hysteresis	ΔV_{UVLO}	—	150	—	mV	V_{UVLO} falling

TEMPERATURE SPECIFICATIONS

Parameter	Sym.	Min.	Typ.	Max.	Unit	Conditions
TEMPERATURE RANGE						
Operating Ambient Temperature	T_A	-40	—	+125	$^\circ\text{C}$	
Maximum Junction Temperature	T_J	—	—	+150	$^\circ\text{C}$	
Storage Temperature	T_S	-65	—	+150	$^\circ\text{C}$	
PACKAGE THERMAL RESISTANCE						
8-lead SOIC	θ_{JA}	—	101	—	$^\circ\text{C/W}$	

HV9803

2.0 PIN DESCRIPTION

The details on the pins of HV9803 are listed in [Table 2-1](#). See location of pins in [Package Type](#).

TABLE 2-1: PIN FUNCTION TABLE

Pin Number	Pin Name	Description
1	CS	This pin is the current sense pin used to detect the MOSFET source current by means of an external sense resistor.
2	VDD	This is the power supply input for the GATE output and input of the low-voltage regulator powering the internal logic. It must be bypassed with a low-ESR capacitor to GND (at least 0.1 μ F).
3	GND	Ground return for all internal circuitry. This pin must be electrically connected to the ground of the power train.
4	GATE	This pin is the output of gate driver for an external N-channel power MOSFET.
5	RT	A resistor connected between RT and GND programs the GATE offtime.
6	PWMD	This is the PWM dimming input of the IC. When this pin is pulled to GND, the gate driver is turned off. When the pin is pulled high, the gate driver operates normally.
7	UVLO	This pin is the undervoltage comparator input. It is also used to program a short-circuit protection skip delay.
8	LD	This pin is the reference voltage input for programming the LED current.

3.0 FUNCTIONAL DESCRIPTION

3.1 General

The peak-current control of a buck converter is the most economical and simplest way to regulate its output current. However, it suffers accuracy and regulation problems that arise from the peak-to-average current error due to the current ripple in the output inductor and the propagation delay in the current sense comparator. The full inductor current signal is unavailable for switch current sensing with current-sensing resistor in the ground path between the low-side switch and ground in a buck converter with low-side main switch configuration when the switch is turned-on. While it is very simple to detect the peak current in the switch, controlling the average inductor current is usually implemented by level-translating the current sense signal from the positive input supply rail. While this is practical for relatively low-input voltage, this type of average-current control may become excessively complex and expensive in the case of input voltages above 100V.

The HV9803 uses a control scheme that senses only the switch current to quickly and accurately control the average current in the buck inductor. No compensation of the current control loop is required. The inductor current ripple amplitude does not affect this control scheme significantly. The LED current is independent of the variation in inductance, switching frequency and output voltage. Constant offtime control of the buck converter is used for stability and to improve the LED current regulation over a wide range of input voltages. The IC features excellent PWM dimming response.

3.2 OFF Timer

In the HV9803, the timing resistor connected at the RT pin determines the offtime of the gate driver, and the resistor must be wired to GND. The equation governing the offtime of the GATE output is derived with [Equation 3-1](#).

EQUATION 3-1:

$$T_{OFF} = R_T \times 40pF$$

The RT input is protected from short circuit. Overcurrent condition at RT inhibits the IC.

3.3 Current Sense Comparator and Timer Circuits

The function of the HV9803's current sense comparator is similar to that of a peak current controller. However, the GATE pulse is not terminated immediately as the CS threshold is met. The GATE turn-off in the nth cycle is delayed by a time $T_{2,n}$ determined by a timer circuit as shown in [Equation 3-2](#).

EQUATION 3-2:

$$T_{2,n} = \frac{1}{2} \times (T_{1,n} + T_{1,n-1})$$

Where $T_{1,n}$ and $T_{1,n-1}$ are the times to the CS threshold in any two consecutive switching cycles.

This iterative control law is needed for damping sub-harmonic oscillation. Note that the control law is only valid up to a maximum switching duty cycle, $D_{MAX} = 0.8$. Exceeding D_{MAX} will cause a reduction in the LED current.

Propagation delay in the current sense comparator is one of the most significant contributors to the LED current error. It must be noted that the control scheme described above does not improve this deficiency of the peak-current control scheme by itself. Moreover, it samples the propagation delay during T_1 and replicates it during T_2 , essentially doubling the error introduced by this delay. To eliminate this error, the reference voltage is corrected by an auto-zero circuit. In essence, the HV9803 samples its CS signal when the current sense comparator triggers and detects the difference between the sampled CS level and the reference input of the current sense comparator. The resulting difference is subtracted from the reference level to generate a new reference in the next switching cycle.

3.4 GATE Output

The GATE output of the HV9803 is used to drive an external MOSFET. It is recommended that the gate charge Q_G of the external MOSFET should be less than 25 nC for switching frequencies ≤ 100 kHz and less than 15 nC for switching frequencies > 100 kHz.

The resulting LED current is calculated using [Equation 3-3](#).

EQUATION 3-3:

$$I_{LED} = \frac{0.49 \times V_{LD} - 6mV}{R_{CS}}$$

3.5 Short-Circuit Protection

The HV9803 is equipped with a short-circuit protection comparator having another CS threshold V_{LIM} . When this second threshold is triggered, the GATE output shuts off for the duration of a restart delay, determined by the RC constant set at UVLO pin. Meanwhile, the capacitor C_{SKIP} is discharged below 200 mV. The restart delay due to charging C_{SKIP} to the UVLO upper threshold is calculated as shown in [Equation 3-4](#).

EQUATION 3-4:

$$T_{SKIP} = k \times R_1 \times C_{SKIP} \times I_n \times \left(\frac{k \times V_{IN} - 0.30V}{k \times V_{IN} - 1.17V} \right)$$

Where:

$$k = \frac{R_2}{R_1 + R_2}$$

3.6 Undervoltage Shutdown

Undervoltage comparator input is provided to disable the IC when the UVLO input is below the UVLO lower threshold. Hysteresis is provided to avoid oscillation.

3.7 Failure Modes and Effects Analysis (FMEA)

The HV9803 is designed to withstand short circuit between its adjacent pins without damage. [Table 3-1](#) describes the effect of such incidental short-circuit conditions.

TABLE 3-1: SHORT-CIRCUIT MODES AND EFFECTS

Short-Circuit Mode	Effect
CS to V_{DD}	The IC triggers the short-circuit protection and operates in the Auto-restart mode continuously.
V_{DD} to GND	Short circuit across the 12V should cause the external bias supply overcurrent protection.
GND to GATE	This should cause the external bias supply overcurrent protection. The power MOSFET Q1 is off.
RT to PWM	Case 1—PWM = Lo: The RT pin sources its maximum current. GATE = 0V and Q1 is off. Case 2—PWM = Hi: The RT pin is pulled up, shutting off the timer. GATE is off.
PWM to UVLO	This overdrives the undervoltage threshold. However, since the V_{IN} UV condition is harmless to the IC, there is no effect.
UVLO to LD	LD overdrives the UVLO. If LD is lower than the UVLO lower threshold, the IC shuts off. No effect otherwise.

4.0 PACKAGING INFORMATION

4.1 Package Marking Information

8-lead SOIC

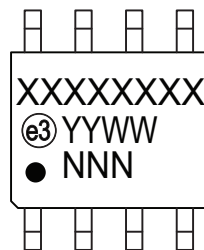

Example

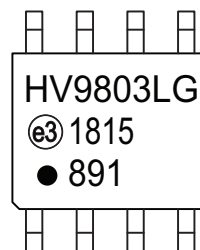

Legend:	XX...X	Product Code or Customer-specific information
	Y	Year code (last digit of calendar year)
	YY	Year code (last 2 digits of calendar year)
	WW	Week code (week of January 1 is week '01')
	NNN	Alphanumeric traceability code
	(e3)	Pb-free JEDEC® designator for Matte Tin (Sn)
	*	This package is Pb-free. The Pb-free JEDEC designator (e3) can be found on the outer packaging for this package.
Note:	In the event the full Microchip part number cannot be marked on one line, it will be carried over to the next line, thus limiting the number of available characters for product code or customer-specific information. Package may or not include the corporate logo.	

HV9803

8-Lead SOIC (Narrow Body) Package Outline (LG/TG) 4.90x3.90mm body, 1.75mm height (max), 1.27mm pitch

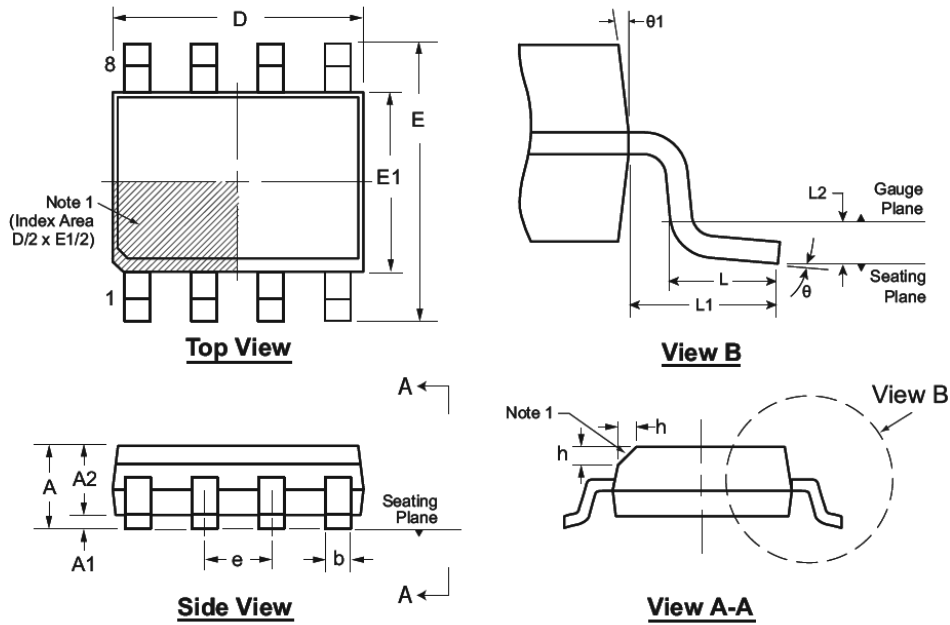

Note: For the most current package drawings, see the Microchip Packaging Specification at www.microchip.com/packaging.

Note:

1. This chamfer feature is optional. A Pin 1 identifier must be located in the index area indicated. The Pin 1 identifier can be: a molded mark/identifier; an embedded metal marker; or a printed indicator.

Symbol	A	A1	A2	b	D	E	E1	e	h	L	L1	L2	θ	$\theta 1$		
Dimension (mm)	MIN	1.35*	0.10	1.25	0.31	4.80*	5.80*	3.80*	1.27 BSC	0.25	0.40	1.04 REF	0.25	BSC	0°	5°
	NOM	-	-	-	-	4.90	6.00	3.90		-	-		-		-	
	MAX	1.75	0.25	1.65*	0.51	5.00*	6.20*	4.00*		0.50	1.27		8°		15°	

JEDEC Registration MS-012, Variation AA, Issue E, Sept. 2005.

* This dimension is not specified in the JEDEC drawing.

Drawings are not to scale.

APPENDIX A: REVISION HISTORY

Revision A (August 2018)

- Converted Supertex Doc# DSFP-HV9803 to Microchip DS20005641A
- Changed the packaging quantity for the 8-lead SOIC LG package from 2500/Reel to 3300/Reel
- Added a maximum junction temperature to the Temperature Specifications Table
- Made minor text changes throughout the document

HV9803

PRODUCT IDENTIFICATION SYSTEM

To order or obtain information, e.g., on pricing or delivery, contact your local Microchip representative or sales office.

PART NO.	XX	-	X	-	X
Device	Package Options		Environmental		Media Type
Device:	HV9803	=	LED Driver IC with Average-Mode Constant Current Control		
Package:	LG	=	8-lead SOIC		
Environmental:	G	=	Lead (Pb)-free/RoHS-compliant Package		
Media Type:	(blank)	=	3300/Reel for an LG Package		

Example:

a) HV9803LG-G: LED Driver IC with Average-Mode Constant Current Control, 8-lead SOIC Package, 3300/Reel

Note the following details of the code protection feature on Microchip devices:

- Microchip products meet the specification contained in their particular Microchip Data Sheet.
- Microchip believes that its family of products is one of the most secure families of its kind on the market today, when used in the intended manner and under normal conditions.
- There are dishonest and possibly illegal methods used to breach the code protection feature. All of these methods, to our knowledge, require using the Microchip products in a manner outside the operating specifications contained in Microchip's Data Sheets. Most likely, the person doing so is engaged in theft of intellectual property.
- Microchip is willing to work with the customer who is concerned about the integrity of their code.
- Neither Microchip nor any other semiconductor manufacturer can guarantee the security of their code. Code protection does not mean that we are guaranteeing the product as “unbreakable.”

Code protection is constantly evolving. We at Microchip are committed to continuously improving the code protection features of our products. Attempts to break Microchip's code protection feature may be a violation of the Digital Millennium Copyright Act. If such acts allow unauthorized access to your software or other copyrighted work, you may have a right to sue for relief under that Act.

Information contained in this publication regarding device applications and the like is provided only for your convenience and may be superseded by updates. It is your responsibility to ensure that your application meets with your specifications. MICROCHIP MAKES NO REPRESENTATIONS OR WARRANTIES OF ANY KIND WHETHER EXPRESS OR IMPLIED, WRITTEN OR ORAL, STATUTORY OR OTHERWISE, RELATED TO THE INFORMATION, INCLUDING BUT NOT LIMITED TO ITS CONDITION, QUALITY, PERFORMANCE, MERCHANTABILITY OR FITNESS FOR PURPOSE. Microchip disclaims all liability arising from this information and its use. Use of Microchip devices in life support and/or safety applications is entirely at the buyer's risk, and the buyer agrees to defend, indemnify and hold harmless Microchip from any and all damages, claims, suits, or expenses resulting from such use. No licenses are conveyed, implicitly or otherwise, under any Microchip intellectual property rights unless otherwise stated.

Microchip received ISO/TS-16949:2009 certification for its worldwide headquarters, design and wafer fabrication facilities in Chandler and Tempe, Arizona; Gresham, Oregon and design centers in California and India. The Company's quality system processes and procedures are for its PIC® MCUs and dsPIC® DSCs, KEELOQ® code hopping devices, Serial EEPROMs, microperipherals, nonvolatile memory and analog products. In addition, Microchip's quality system for the design and manufacture of development systems is ISO 9001:2000 certified.

**QUALITY MANAGEMENT SYSTEM
CERTIFIED BY DNV
= ISO/TS 16949 =**

Trademarks

The Microchip name and logo, the Microchip logo, AnyRate, AVR, AVR logo, AVR Freaks, BitCloud, chipKIT, chipKIT logo, CryptoMemory, CryptoRF, dsPIC, FlashFlex, flexPWR, Heldo, JukeBlox, KeeLoq, Klear, LANCheck, LINK MD, maXStylus, maXTouch, MediaLB, megaAVR, MOST, MOST logo, MPLAB, OptoLyzer, PIC, picoPower, PICSTART, PIC32 logo, Prochip Designer, QTouch, SAM-BA, SpyNIC, SST, SST Logo, SuperFlash, tinyAVR, UNI/O, and XMEGA are registered trademarks of Microchip Technology Incorporated in the U.S.A. and other countries.

ClockWorks, The Embedded Control Solutions Company, EtherSynch, Hyper Speed Control, HyperLight Load, IntellIMOS, mTouch, Precision Edge, and Quiet-Wire are registered trademarks of Microchip Technology Incorporated in the U.S.A.

Adjacent Key Suppression, AKS, Analog-for-the-Digital Age, Any Capacitor, AnyIn, AnyOut, BodyCom, CodeGuard, CryptoAuthentication, CryptoAutomotive, CryptoCompanion, CryptoController, dsPICDEM, dsPICDEM.net, Dynamic Average Matching, DAM, ECAN, EtherGREEN, In-Circuit Serial Programming, ICSP, INICnet, Inter-Chip Connectivity, JitterBlocker, KlearNet, KlearNet logo, memBrain, Mindi, MiWi, motorBench, MPASM, MPF, MPLAB Certified logo, MPLIB, MPLINK, MultiTRAK, NetDetach, Omniscient Code Generation, PICDEM, PICDEM.net, PICKit, PICtail, PowerSmart, PureSilicon, QMatrix, REAL ICE, Ripple Blocker, SAM-ICE, Serial Quad I/O, SMART-I.S., SQI, SuperSwitcher, SuperSwitcher II, Total Endurance, TSHARC, USBCheck, VariSense, ViewSpan, WiperLock, Wireless DNA, and ZENA are trademarks of Microchip Technology Incorporated in the U.S.A. and other countries.

SQTP is a service mark of Microchip Technology Incorporated in the U.S.A.

Silicon Storage Technology is a registered trademark of Microchip Technology Inc. in other countries.

GestIC is a registered trademark of Microchip Technology Germany II GmbH & Co. KG, a subsidiary of Microchip Technology Inc., in other countries.

All other trademarks mentioned herein are property of their respective companies.

© 2018, Microchip Technology Incorporated, All Rights Reserved.
ISBN: 978-1-5224-3476-4



MICROCHIP

Worldwide Sales and Service

AMERICAS

Corporate Office
2355 West Chandler Blvd.
Chandler, AZ 85224-6199
Tel: 480-792-7200
Fax: 480-792-7277
Technical Support:
<http://www.microchip.com/support>
Web Address:
www.microchip.com

Atlanta

Duluth, GA
Tel: 678-957-9614
Fax: 678-957-1455

Austin, TX

Tel: 512-257-3370

Boston

Westborough, MA
Tel: 774-760-0087
Fax: 774-760-0088

Chicago

Itasca, IL
Tel: 630-285-0071
Fax: 630-285-0075

Dallas

Addison, TX
Tel: 972-818-7423
Fax: 972-818-2924

Detroit

Novi, MI
Tel: 248-848-4000

Houston, TX

Tel: 281-894-5983

Indianapolis

Noblesville, IN
Tel: 317-773-8323
Fax: 317-773-5453
Tel: 317-536-2380

Los Angeles

Mission Viejo, CA
Tel: 949-462-9523
Fax: 949-462-9608
Tel: 951-273-7800

Raleigh, NC

Tel: 919-844-7510

New York, NY

Tel: 631-435-6000

San Jose, CA

Tel: 408-735-9110
Tel: 408-436-4270

Canada - Toronto

Tel: 905-695-1980
Fax: 905-695-2078

ASIA/PACIFIC

Australia - Sydney
Tel: 61-2-9868-6733

China - Beijing
Tel: 86-10-8569-7000

China - Chengdu
Tel: 86-28-8665-5511

China - Chongqing
Tel: 86-23-8980-9588

China - Dongguan
Tel: 86-769-8702-9880

China - Guangzhou
Tel: 86-20-8755-8029

China - Hangzhou
Tel: 86-571-8792-8115

China - Hong Kong SAR
Tel: 852-2943-5100

China - Nanjing
Tel: 86-25-8473-2460

China - Qingdao
Tel: 86-532-8502-7355

China - Shanghai
Tel: 86-21-3326-8000

China - Shenyang
Tel: 86-24-2334-2829

China - Shenzhen
Tel: 86-755-8864-2200

China - Suzhou
Tel: 86-186-6233-1526

China - Wuhan
Tel: 86-27-5980-5300

China - Xian
Tel: 86-29-8833-7252

China - Xiamen
Tel: 86-592-2388138

China - Zhuhai
Tel: 86-756-3210040

ASIA/PACIFIC

India - Bangalore
Tel: 91-80-3090-4444

India - New Delhi
Tel: 91-11-4160-8631

India - Pune
Tel: 91-20-4121-0141

Japan - Osaka
Tel: 81-6-6152-7160

Japan - Tokyo
Tel: 81-3-6880-3770

Korea - Daegu
Tel: 82-53-744-4301

Korea - Seoul
Tel: 82-2-554-7200

Malaysia - Kuala Lumpur
Tel: 60-3-7651-7906

Malaysia - Penang
Tel: 60-4-227-8870

Philippines - Manila
Tel: 63-2-634-9065

Singapore
Tel: 65-6334-8870

Taiwan - Hsin Chu
Tel: 886-3-577-8366

Taiwan - Kaohsiung
Tel: 886-7-213-7830

Taiwan - Taipei
Tel: 886-2-2508-8600

Thailand - Bangkok
Tel: 66-2-694-1351

Vietnam - Ho Chi Minh
Tel: 84-28-5448-2100

EUROPE

Austria - Wels
Tel: 43-7242-2244-39
Fax: 43-7242-2244-393

Denmark - Copenhagen
Tel: 45-4450-2828
Fax: 45-4485-2829

Finland - Espoo
Tel: 358-9-4520-820

France - Paris
Tel: 33-1-69-53-63-20
Fax: 33-1-69-30-90-79

Germany - Garching
Tel: 49-8931-9700

Germany - Haan
Tel: 49-2129-3766400

Germany - Heilbronn
Tel: 49-7131-67-3636

Germany - Karlsruhe
Tel: 49-721-625370

Germany - Munich
Tel: 49-89-627-144-0
Fax: 49-89-627-144-44

Germany - Rosenheim
Tel: 49-8031-354-560

Israel - Ra'anana
Tel: 972-9-744-7705

Italy - Milan
Tel: 39-0331-742611
Fax: 39-0331-466781

Italy - Padova
Tel: 39-049-7625286

Netherlands - Drunen
Tel: 31-416-690399
Fax: 31-416-690340

Norway - Trondheim
Tel: 47-7288-4388

Poland - Warsaw
Tel: 48-22-3325737

Romania - Bucharest
Tel: 40-21-407-87-50

Spain - Madrid
Tel: 34-91-708-08-90
Fax: 34-91-708-08-91

Sweden - Gothenberg
Tel: 46-31-704-60-40

Sweden - Stockholm
Tel: 46-8-5090-4654

UK - Wokingham
Tel: 44-118-921-5800
Fax: 44-118-921-5820

X-ON Electronics

Largest Supplier of Electrical and Electronic Components

Click to view similar products for [LED Lighting Drivers](#) category:

Click to view products by [Supertex](#) manufacturer:

Other Similar products are found below :

[LV5235V-MPB-H](#) [MB39C602PNF-G-JNEFE1](#) [MIC2871YMK-T5](#) [AL1676-10BS7-13](#) [AL1676-20AS7-13](#) [AP5726WUG-7](#) [MX877RTR](#)
[ICL8201](#) [IS31BL3228B-UTLS2-TR](#) [IS31BL3506B-TTLS2-TR](#) [AL3157F-7](#) [AP5725FDCG-7](#) [AP5726FDCG-7](#) [LV52204MTTBG](#)
[AP5725WUG-7](#) [STP4CMPQTR](#) [NCL30086BDR2G](#) [CAT4004BHU2-GT3](#) [LV52207AXA-VH](#) [AP1694AS-13](#) [TLE4242EJ](#) [AS3688](#)
[IS31LT3172-GRLS4-TR](#) [TLD2311EL](#) [KTD2694EDQ-TR](#) [KTZ8864EJAA-TR](#) [IS32LT3174-GRLA3-TR](#) [ZXLD1374QESTTC](#) [MP2488DN-](#)
[LF-Z](#) [NLM0010XTSA1](#) [AL1676-20BS7-13](#) [MPQ7220GF-AEC1-P](#) [MPQ4425BGJ-AEC1-P](#) [MPQ7220GF-AEC1-Z](#) [MPQ4425BGJ-AEC1-Z](#)
[IS31FL3737B-QFLS4-TR](#) [IS31FL3239-QFLS4-TR](#) [KTD2058EUAC-TR](#) [KTD2037EWE-TR](#) [DIO5662ST6](#) [IS31BL3508A-TTLS2-TR](#)
[MAX20052CATC/V+](#) [MAX25606AUP/V+](#) [BD6586MUV-E2](#) [BD9206EFV-E2](#) [BD9416FS-E2](#) [LYT4227E](#) [LYT6079C-TL](#) [MP3394SGF-P](#)
[MP4689AGN-P](#)