

Hysteretic, Buck, High Brightness LED Driver with High-Side Current Sensing

Features

- Hysteretic control with high-side current sensing
- Wide input-voltage range: 4.5 to 40V
- >90% Efficiency
- Typical $\pm 5\%$ LED current accuracy
- Up to 2.0MHz switching frequency
- Adjustable constant LED current
- Analog or PWM control signal for PWM dimming
- Over-temperature protection
- -40°C to $+125^{\circ}\text{C}$ operating temperature range

Applications

- Low-voltage industrial and architectural lighting
- General purpose constant current source
- Signage and decorative LED lighting
- Indicator and emergency lighting

Description

HV9919B is a Pulse-Width Modulation (PWM) controller IC designed to drive high-brightness LEDs using a buck topology. It operates from an input voltage of 4.5 to 40VDC and employs hysteretic control, with a high-side current sense resistor, to set the constant output current.

Set the operating frequency range by selecting the proper inductor. Operation at high switching frequency is possible since the hysteretic control maintains accuracy even at high frequencies. This permits the use of small inductors and capacitors, minimizing space and cost in the overall system.

LED brightness control is achieved with PWM dimming from an analog or PWM input signal. Unique PWM circuitry allows true constant color with a high dimming range. The dimming frequency is programmed using a single external capacitor.

HV9919B comes in a small, 8-Lead DFN package and is ideal for industrial and general lighting applications.

Package Type

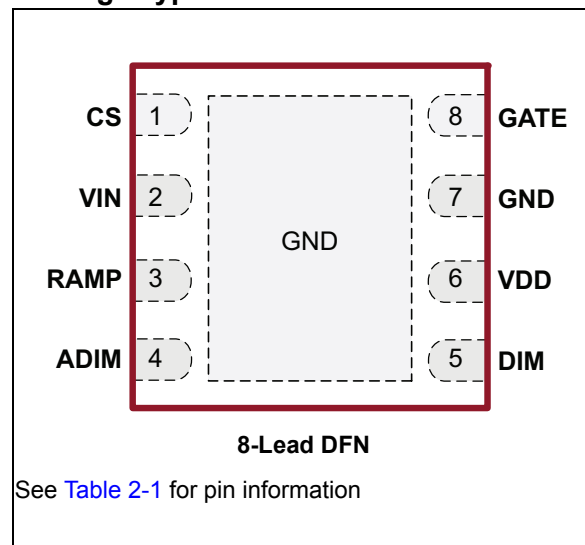

HV9919B

Block Diagram

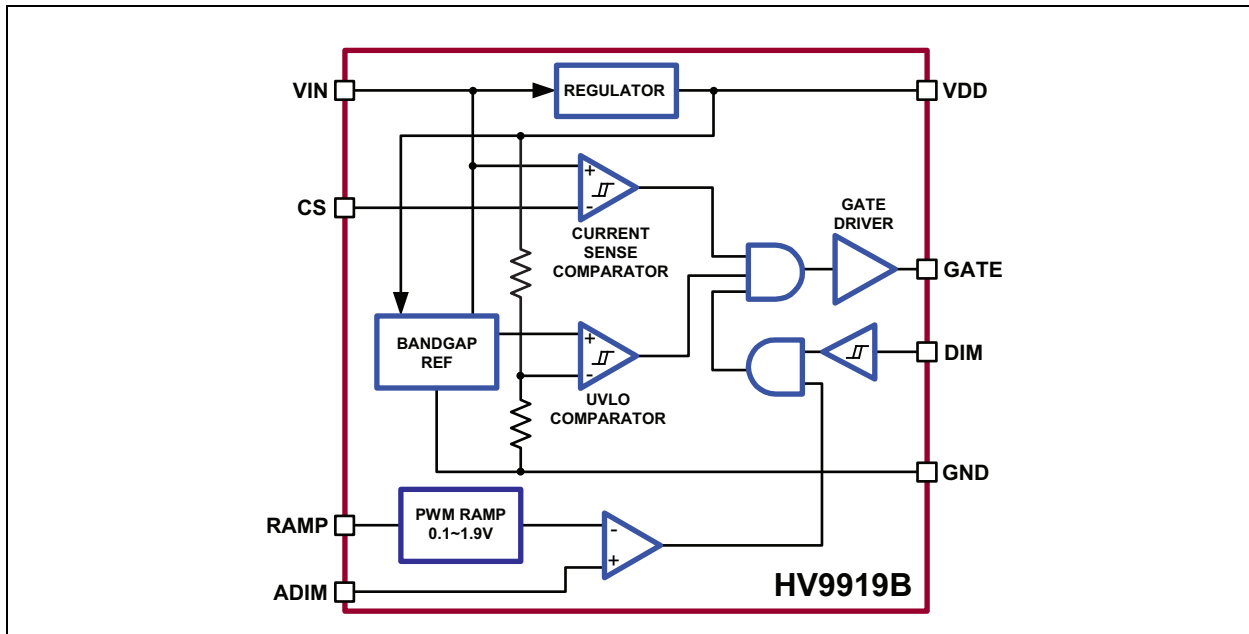

Typical Application Circuit

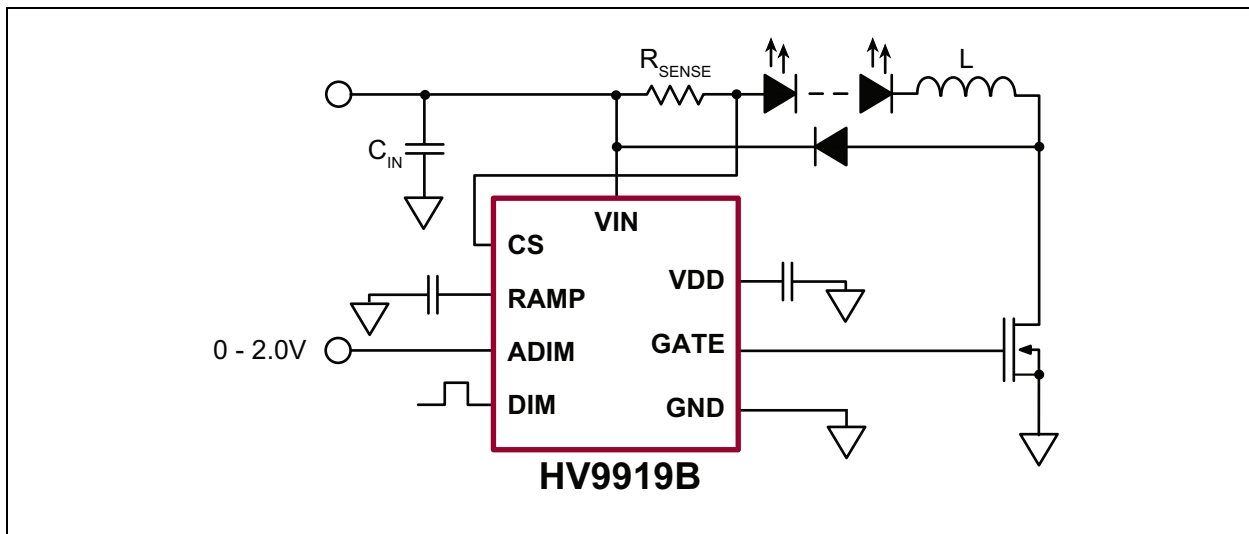

1.0 ELECTRICAL CHARACTERISTICS

ABSOLUTE MAXIMUM RATINGS†

V _{IN} to GND	-0.3V to +45V
V _{DD} to GND	-0.3V to +6.0V
GATE, RAMP, DIM, ADIM to GND	-0.3V to +V _{DD}
CS to V _{IN}	-1.0V to +0.3V
Continuous total power dissipation (T _A = 25. °C)	1.6W
Operating temperature range	-40°C to +125°C
Junction temperature	+150°C
Storage temperature range	-65°C to +150°C

† **Notice:** Stresses above those listed under “Maximum Ratings” may cause permanent damage to the device. This is a stress rating only and functional operation of the device at those or any other conditions above those indicated in the operational listings of this specification is not implied. Exposure to maximum rating conditions for extended periods may affect device reliability.

TABLE 1-1: ELECTRICAL CHARACTERISTICS (SHEET 1 OF 2)

Parameter	Symbol	Min	Typ	Max	Units	Conditions
Electrical Specifications: V _{IN} =12V, V _{DIM} = V _{DD} , V _{RAMP} = GND, C _{VDD} = 1.0 μF, R _{CS} = 0.5Ω, T _A = T _J = -40°C to +125°C, unless otherwise noted. (Note 1)						
Input DC supply voltage range	V _{IN}	4.5	-	40	V	DC input voltage
Internally regulated voltage	V _{DD}	4.5	-	5.5	V	V _{IN} = 6.0 to 40V
Supply current	I _{IN}	-	-	1.5	mA	GATE open
Shutdown supply current	I _{IN, SDN}	-	-	900	μA	DIM < 0.7V
Current limit	I _{IN, LIM}	-	11	-	mA	V _{IN} = 4.5V, V _{DD} = 0V
		-	5.5	-		V _{IN} = 4.5V, V _{DD} = 4.0V
Switching frequency	f _{SW}	-	-	2.0	MHz	-
V _{DD} Undervoltage lockout threshold	UVLO	-	-	4.5	V	V _{DD} rising
V _{DD} Undervoltage lockout hysteresis	ΔUVLO	-	500	-	mV	V _{DD} falling
Sense Comparator						
Sense voltage threshold high	V _{CS(HI)}	-	230	-	mV	(V _{IN} - V _{CS}) rising
Sense voltage threshold low	V _{CS(LO)}	-	170	-	mV	(V _{IN} - V _{CS}) falling
Average sense voltage	V _{CS(AVG)}	186	200	214	mV	V _{CS(AVG)} = 0.5(V _{CS(HI)} + V _{CS(LO)})
Propagation delay to output high	t _{DPDH}	-	70	-	ns	Falling edge of (V _{IN} - V _{CS}) = V _{RS(LO)} - 70mV
Propagation delay to output low	t _{DPDL}	-	70	-	ns	Rising edge of (V _{IN} - V _{CS}) = V _{RS(HI)} + 70mV
Current-sense input current	I _{CS}	-	-	1.0	μA	(V _{IN} - V _{CS}) = 200mV
Current-sense threshold hysteresis	V _{CS(HYS)}	15	56	98	mV	V _{CS(HYS)} = V _{CS(HI)} - V _{CS(LO)}
DIM Input						
Pin DIM input high voltage	V _{IH}	2.2	-	-	V	-
Pin DIM input low voltage	V _{IL}	-	-	0.7	V	-
Turn-on time	t _{ON}	-	100	-	ns	DIM rising edge to V _{GATE} = 0.5 x V _{DD} , C _{GATE} = 2.0nF
Turn-off time	t _{OFF}	-	100	-	ns	DIM falling edge to V _{GATE} = 0.5 x V _{DD} , C _{GATE} =2.0nF

HV9919B

TABLE 1-1: ELECTRICAL CHARACTERISTICS (SHEET 2 OF 2)

Electrical Specifications: $V_{IN}=12V$, $V_{DIM} = V_{DD}$, $V_{RAMP} = GND$, $C_{VDD} = 1.0 \mu F$, $R_{CS} = 0.5\Omega$, $T_A = T_J = -40^\circ C$ to $+125^\circ C$, unless otherwise noted. (Note 1)						
Parameter	Symbol	Min	Typ	Max	Units	Conditions
GATE Driver						
GATE current, source	I_{GATE}	0.3	0.5	-	A	$V_{GATE} = GND$, (Note 2)
GATE current, sink		0.7	1.0	-	A	$V_{GATE} = V_{DD}$, (Note 2)
GATE output rise time	T_{RISE}	-	40	55	ns	$C_{GATE} = 2.0nF$
GATE output fall time	T_{FALL}	-	17	25	ns	$C_{GATE} = 2.0nF$
GATE high output voltage	$V_{GATE(HI)}$	$V_{DD}-0.5$	-	-	V	$I_{GATE} = 10mA$
GATE low output voltage	$V_{GATE(LO)}$	-	-	0.5	V	$I_{GATE} = -10mA$
Over-Temperature Protection						
Over temperature trip limit	T_{OT}	128	140	-	$^\circ C$	(Note 2)
Temperature hysteresis	ΔT_{HYST}	-	60	-	$^\circ C$	(Note 2)
Analog Control of PWM Dimming						
Dimming frequency	f_{RAMP}	114	-	308	Hz	$C_{RAMP} = 47nF$
		529	-	1380		$C_{RAMP} = 10nF$
RAMP threshold, Low	V_{LOW}	-	0.1	-	V	-
RAMP threshold, High	V_{HIGH}	1.8	-	2.1	V	-
ADIM offset voltage	V_{OS}	-35	-	+35	mV	-

Note 1: Specification is obtained by characterization and is 100% tested at $T_A = 25^\circ C$.

2: Specification is obtained by characterization and not 100% tested

TEMPERATURE SPECIFICATIONS

Electrical Specifications: Unless otherwise specified, for all specifications $T_A = T_J = +25^\circ C$						
Parameter	Symbol	Min	Typ	Max	Units	Conditions
Temperature Ranges						
Operating Temperature		-40		125	$^\circ C$	
Storage Temperature		-65	-	150	$^\circ C$	
Package Thermal Resistances						
Thermal Resistance, DFN	θ_{ja}	-	60	-	$^\circ C/W$	Mounted on FR-4 board, 25 mm x 25 mm x 1.57 mm

2.0 PIN DESCRIPTION

The locations of the pins are listed in [Features](#).

TABLE 2-1: PIN DESCRIPTION

Pin #	Symbol	Description
1	CS	Current sense input. Senses LED string current.
2	VIN	Input voltage 4.5 to 40V DC.
3	RAMP	Analog PWM dimming ramp output.
4	ADIM	Analog 0~2.0V signal input for analog control of PWM dimming.
5	DIM	PWM signal input.
6	VDD	Internally regulated supply voltage. Connect a capacitor from V _{DD} to ground.
7	GND	Device ground.
8	GATE	Drives gate of external MOSFET.
TAB	GND	Must be wired to pin 7 on PCB.

HV9919B

3.0 APPLICATION INFORMATION

HV9919B is a step-down, constant current, High-Brightness LED (HB LED) driver. The device operates from a 4.5 to 40V input voltage range and provides the gate drive output to an external N-channel MOSFET.

A high-side, current-sense resistor sets the output current and a dedicated PWM Dimming Input (DIM) allows for a wide range of dimming duty ratios. The PWM dimming could also be achieved by applying a DC voltage between 0 and 2.0V to the Analog Dimming Input (ADIM). In this case, the dimming frequency can be programmed using a single capacitor at the RAMP pin.

The high-side current setting and sensing scheme minimizes the number of external components while delivering LED current with a $\pm 8\%$ accuracy, using a 1% sense resistor.

3.1 Undervoltage Lockout (UVLO)

HV9919B includes a 3.7V Under-Voltage lockout (UVLO) with 500mV hysteresis. When V_{DD} falls below 3.7V, GATE goes low, turning off the external N-channel MOSFET. GATE goes high once V_{DD} is 4.5V or higher.

3.2 5.0V Regulator

V_{DD} is the output of a 5.0V regulator capable of sourcing 5.0 mA. Bypass V_{DD} to GND with a 1.0 μ F capacitor.

3.3 DIM Input

HV9919B allows dimming with a PWM signal at the DIM input. A logic level below 0.7V at DIM forces the GATE output low, turning off the LED current. To turn the LED current on, the logic level at DIM must be at least 2.2V.

3.4 ADIM and RAMP Inputs

The PWM dimming scheme can be also implemented by applying an analog control signal to ADIM pin. If an analog control signal of 0 – 2.0V is applied to ADIM, the device compares this analog input to a voltage ramp to pulse-width-modulate the LED current. Connecting an external capacitor to RAMP programs the PWM dimming ramp frequency.

$$f_{PWM} = \frac{1}{C_{RAMP} \cdot 120K\Omega}$$

DIM and ADIM inputs can be used simultaneously. In such a case, $f_{PWM(MAX)}$ must be selected lower than the frequency of the dimming signal at DIM. The smaller dimming duty cycle of ADIM and DIM will determine the GATE signal.

When the analog control of PWM dimming feature is not used, RAMP must be wired to GND, and ADIM should be connected to V_{DD} .

One possible application of the ADIM feature of HV9919B may include protection of the LED load from over-temperature by connecting an NTC thermistor at ADIM, as shown in Figure 3-1

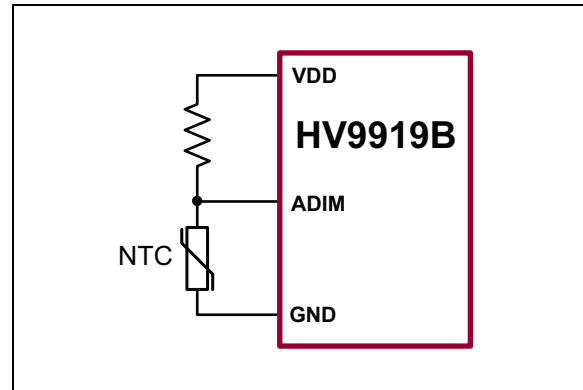

FIGURE 3-1: NTC Thermistor at ADIM

3.5 Setting LED Current with External Resistor R_{SENSE}

The output current in the LED is determined by the external current sense resistor (R_{SENSE}) connected between V_{IN} and CS. Disregarding the effect of the propagation delays, the sense resistor can be calculated as:

$$R_{SENSE} \approx \frac{1}{2} \cdot \frac{(V_{CS(HI)} + V_{CS(LO)})}{I_{LED}} = \frac{200mV}{I_{LED}}$$

3.6 Selecting Buck Inductor L

HV9919B regulates the LED output current using a comparator with hysteresis, see Figure 3-2. As the current through the inductor ramps up and the voltage across the sense resistor reaches the upper threshold, the voltage at GATE goes low, turning off the external MOSFET. The MOSFET turns on again when the inductor current ramps down through the freewheeling diode, until the voltage across the sense resistor equals the lower threshold. Use the following equation to determine the inductor value for a desired value of operating frequency f_S :

$$L = \frac{(V_{IN} - V_{OUT})V_{OUT}}{f_S V_{IN} \Delta I_O} - \frac{V_{IN} - V_{OUT} t_{DPDL}}{\Delta I_O} - \frac{V_{OUT} t_{DPDH}}{\Delta I_O}$$

Where:

$$\Delta I_O = \frac{V_{CS(HI)} - V_{CS(LO)}}{R_{SENSE}}$$

and t_{DPDL} , t_{DPDH} are the propagation delays. The current ripple ΔI in the inductor L is greater than ΔI_O .

This ripple can be calculated from the following equation:

$$\Delta I = \Delta I_O + \frac{(V_{IN} - V_{OUT})t_{DPDL}}{L} + \frac{V_{OUT}t_{DPDH}}{L}$$

For the purpose of the proper inductor selection, note that the maximum switching frequency occurs at the highest V_{IN} and $V_{OUT} = V_{IN}/2$.

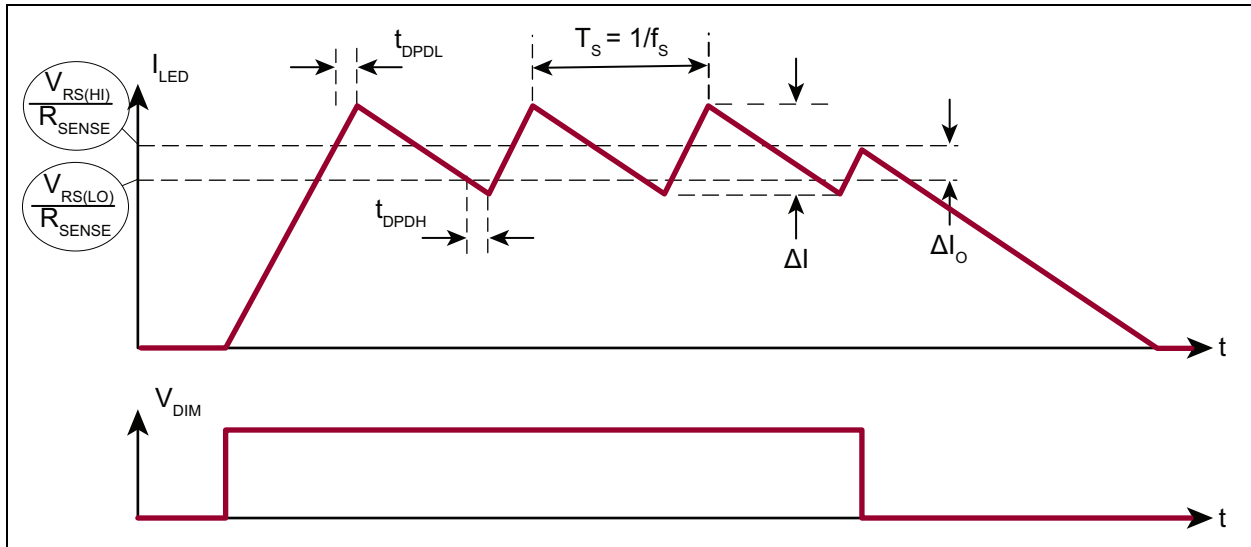

FIGURE 3-2: Regulating LED output

3.7 MOSFET Selection

MOSFET selection is based on the maximum input operating voltage V_{IN} , output current I_{LED} , and operating switching frequency. Choose a logic-level MOSFET that has a higher breakdown voltage than the maximum operation voltage, low $R_{DS(ON)}$, and low total gate charge for better efficiency.

3.8 Freewheeling Diode Selection

The forward voltage of the freewheeling diode should be as low as possible for better efficiency. A Schottky diode is a good choice as long as the breakdown voltage is high enough to withstand the maximum operating voltage. The forward-current rating of the diode must be at least equal to the maximum LED current.

3.9 LED Current Ripple

The LED current ripple is equal to the inductor-current ripple. In cases when a lower LED current ripple is needed, a capacitor can be placed across the LED terminals.

3.10 PCB Layout Guidelines

Careful PCB layout is critical to achieve low switching losses and stable operation. Use a multilayer board whenever possible for better noise immunity. Minimize ground noise by connecting high-current ground returns, the input bypass capacitor ground lead, and the output filter ground lead to a single point (star ground configuration). The fast di/dt loop is formed by the input capacitor C_{IN} , the free-wheeling diode and the MOSFET. To minimize noise interaction, this loop area should be as small as possible. Place R_{SENSE} as close as possible to the input filter and V_{IN} . For better noise immunity, a Kelvin connection is strongly recommended between CS and R_{SENSE} . Connect the exposed tab of the IC to a large-area ground plane for improved power dissipation.

HV9919B

4.0 PACKAGING INFORMATION

4.1 Package Marking Information

8-lead DFN

Example

XXXX
YYWW
○NNN

9919
1542
○343

Legend:	XX...X	Product Code or Customer-specific information
	Y	Year code (last digit of calendar year)
	YY	Year code (last 2 digits of calendar year)
	WW	Week code (week of January 1 is week '01')
	NNN	Alphanumeric traceability code
	ⓔ3	Pb-free JEDEC® designator for Matte Tin (Sn)
	*	This package is Pb-free. The Pb-free JEDEC designator ⓔ3 can be found on the outer packaging for this package.

Note:	In the event the full Microchip part number cannot be marked on one line, it will be carried over to the next line, thus limiting the number of available characters for product code or customer-specific information. Package may or not include the corporate logo.
--------------	--

8-Lead DFN Package Outline (K7) 3.00x3.00mm body, 0.80mm height (max), 0.65mm pitch

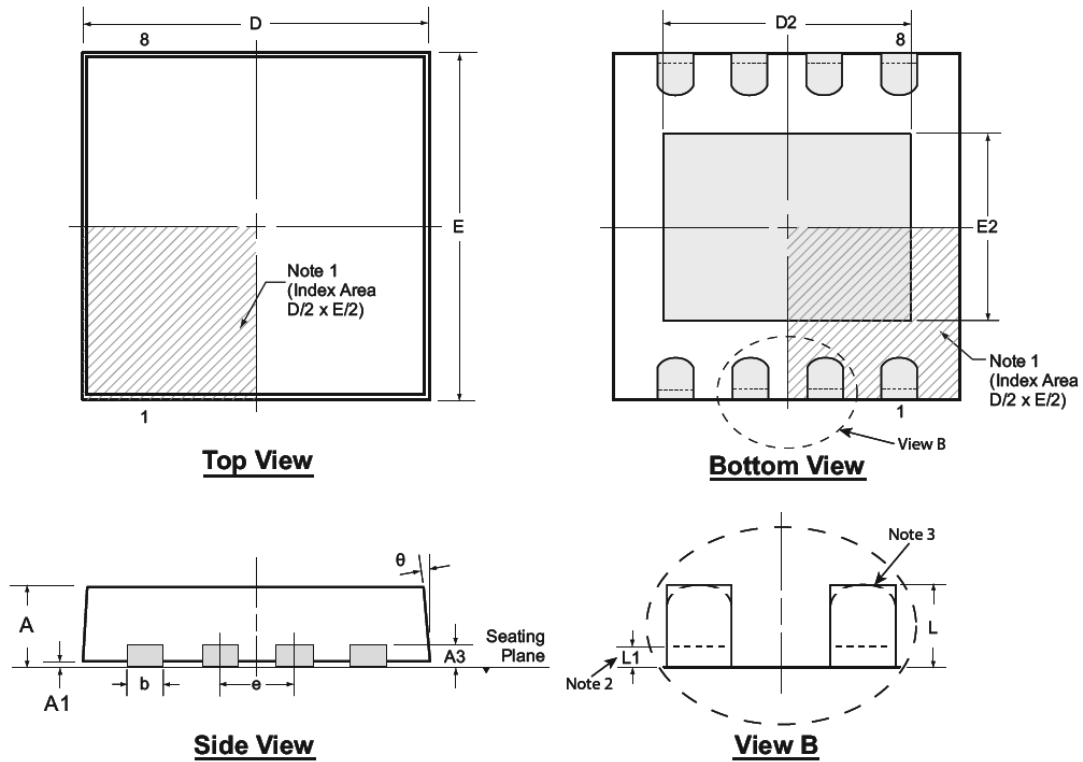

Note: For the most current package drawings, see the Microchip Packaging Specification at www.microchip.com/packaging.

Notes:

1. A Pin 1 identifier must be located in the index area indicated. The Pin 1 identifier can be: a molded mark/identifier; an embedded metal marker; or a printed indicator.
2. Depending on the method of manufacturing, a maximum of 0.15mm pullback (L1) may be present.
3. The inner tip of the lead may be either rounded or square.

Symbol	A	A1	A3	b	D	D2	E	E2	e	L	L1	θ	
Dimension (mm)	MIN	0.70	0.00	0.20 REF	0.25	2.85*	1.60	2.85*	1.35	0.65 BSC	0.30	0.00*	0°
	NOM	0.75	0.02		0.30	3.00	-	3.00	-		0.40	-	-
	MAX	0.80	0.05		0.35	3.15*	2.50	3.15*	1.75		0.50	0.15	14°

JEDEC Registration MO-229, Variation WEEC-2, Issue C, Aug. 2003.

* This dimension is not specified in the JEDEC drawing.

Drawings not to scale.

APPENDIX A: REVISION HISTORY

Revision A (November 2015)

- Updated file to Microchip format.
- Revised **Absolute Maximum Ratings**[†].
- Modified values and notes in **Table 1-1**.
- Added condition to **Temperature Specifications**.
- Changed value in **Section 3.2 “5.0V Regulator”**.
- Wording change in **Section 3.7 “MOSFET Selection”**.
- Minor text changes throughout.

Revision B (December 2015)

- Updated Revision History.

PRODUCT IDENTIFICATION SYSTEM

To order or obtain information, e.g., on pricing or delivery, refer to the factory or the listed sales office.

<u>PART NO.</u>	<u>XX</u>	-	<u>X</u>	-	<u>X</u>
Device	Package Options		Environmental		Media Type
Device:	HV9919B = Hysteretic, Buck, High Brightness LED Driver with High-Side Current Sensing				
Package:	K7	=	48-lead DFN		
Environmental:	G	=	Lead (Pb)-free/ROHS-compliant package		
Media Type:	(blank)	=	3000/Reel		

Examples:

a) HV9919BK7-G 8-Lead DFN package, 3000/Reel

Note the following details of the code protection feature on Microchip devices:

- Microchip products meet the specification contained in their particular Microchip Data Sheet.
- Microchip believes that its family of products is one of the most secure families of its kind on the market today, when used in the intended manner and under normal conditions.
- There are dishonest and possibly illegal methods used to breach the code protection feature. All of these methods, to our knowledge, require using the Microchip products in a manner outside the operating specifications contained in Microchip's Data Sheets. Most likely, the person doing so is engaged in theft of intellectual property.
- Microchip is willing to work with the customer who is concerned about the integrity of their code.
- Neither Microchip nor any other semiconductor manufacturer can guarantee the security of their code. Code protection does not mean that we are guaranteeing the product as “unbreakable.”

Code protection is constantly evolving. We at Microchip are committed to continuously improving the code protection features of our products. Attempts to break Microchip's code protection feature may be a violation of the Digital Millennium Copyright Act. If such acts allow unauthorized access to your software or other copyrighted work, you may have a right to sue for relief under that Act.

Information contained in this publication regarding device applications and the like is provided only for your convenience and may be superseded by updates. It is your responsibility to ensure that your application meets with your specifications. MICROCHIP MAKES NO REPRESENTATIONS OR WARRANTIES OF ANY KIND WHETHER EXPRESS OR IMPLIED, WRITTEN OR ORAL, STATUTORY OR OTHERWISE, RELATED TO THE INFORMATION, INCLUDING BUT NOT LIMITED TO ITS CONDITION, QUALITY, PERFORMANCE, MERCHANTABILITY OR FITNESS FOR PURPOSE. Microchip disclaims all liability arising from this information and its use. Use of Microchip devices in life support and/or safety applications is entirely at the buyer's risk, and the buyer agrees to defend, indemnify and hold harmless Microchip from any and all damages, claims, suits, or expenses resulting from such use. No licenses are conveyed, implicitly or otherwise, under any Microchip intellectual property rights unless otherwise stated.

Trademarks

The Microchip name and logo, the Microchip logo, dsPIC, FlashFlex, flexPWR, JukeBlox, KEELOQ, KEELOQ logo, Kleer, LANCheck, MediaLB, MOST, MOST logo, MPLAB, OptoLyzer, PIC, PICSTART, PIC³² logo, RightTouch, SpyNIC, SST, SST Logo, SuperFlash and UNI/O are registered trademarks of Microchip Technology Incorporated in the U.S.A. and other countries.

The Embedded Control Solutions Company and mTouch are registered trademarks of Microchip Technology Incorporated in the U.S.A.

Analog-for-the-Digital Age, BodyCom, chipKIT, chipKIT logo, CodeGuard, dsPICDEM, dsPICDEM.net, ECAN, In-Circuit Serial Programming, ICSP, Inter-Chip Connectivity, KleerNet, KleerNet logo, MiWi, motorBench, MPASM, MPF, MPLAB Certified logo, MPLIB, MPLINK, MultiTRAK, NetDetach, Omniscient Code Generation, PICDEM, PICDEM.net, PICkit, PICTail, RightTouch logo, REAL ICE, SQI, Serial Quad I/O, Total Endurance, TSHARC, USBCheck, VariSense, ViewSpan, WiperLock, Wireless DNA, and ZENA are trademarks of Microchip Technology Incorporated in the U.S.A. and other countries.

SQTP is a service mark of Microchip Technology Incorporated in the U.S.A.

Silicon Storage Technology is a registered trademark of Microchip Technology Inc. in other countries.

GestIC is a registered trademark of Microchip Technology Germany II GmbH & Co. KG, a subsidiary of Microchip Technology Inc., in other countries.

All other trademarks mentioned herein are property of their respective companies.

© 2015, Microchip Technology Incorporated, Printed in the U.S.A., All Rights Reserved.

ISBN: 978-1-5224-0111-7

QUALITY MANAGEMENT SYSTEM
CERTIFIED BY DNV
== ISO/TS 16949 ==

Microchip received ISO/TS-16949:2009 certification for its worldwide headquarters, design and wafer fabrication facilities in Chandler and Tempe, Arizona; Gresham, Oregon and design centers in California and India. The Company's quality system processes and procedures are for its PIC[®] MCUs and dsPIC[®] DSCs, KEELOQ[®] code hopping devices, Serial EEPROMs, microperipherals, nonvolatile memory and analog products. In addition, Microchip's quality system for the design and manufacture of development systems is ISO 9001:2000 certified.



MICROCHIP

Worldwide Sales and Service

AMERICAS

Corporate Office

2355 West Chandler Blvd.
Chandler, AZ 85224-6199
Tel: 480-792-7200
Fax: 480-792-7277
Technical Support:
<http://www.microchip.com/support>

Web Address:

www.microchip.com

Atlanta

Duluth, GA
Tel: 678-957-9614
Fax: 678-957-1455

Austin, TX

Tel: 512-257-3370

Boston

Westborough, MA
Tel: 774-760-0087
Fax: 774-760-0088

Chicago

Itasca, IL
Tel: 630-285-0071
Fax: 630-285-0075

Cleveland

Independence, OH
Tel: 216-447-0464
Fax: 216-447-0643

Dallas

Addison, TX
Tel: 972-818-7423
Fax: 972-818-2924

Detroit

Novi, MI
Tel: 248-848-4000

Houston, TX

Tel: 281-894-5983

Indianapolis

Noblesville, IN
Tel: 317-773-8323
Fax: 317-773-5453

Los Angeles

Mission Viejo, CA
Tel: 949-462-9523
Fax: 949-462-9608

New York, NY

Tel: 631-435-6000

San Jose, CA

Tel: 408-735-9110

Canada - Toronto

Tel: 905-673-0699
Fax: 905-673-6509

ASIA/PACIFIC

Asia Pacific Office

Suites 3707-14, 37th Floor
Tower 6, The Gateway
Harbour City, Kowloon

Hong Kong

Tel: 852-2943-5100
Fax: 852-2401-3431

Australia - Sydney

Tel: 61-2-9868-6733
Fax: 61-2-9868-6755

China - Beijing

Tel: 86-10-8569-7000
Fax: 86-10-8528-2104

China - Chengdu

Tel: 86-28-8665-5511
Fax: 86-28-8665-7889

China - Chongqing

Tel: 86-23-8980-9588
Fax: 86-23-8980-9500

China - Dongguan

Tel: 86-769-8702-9880

China - Hangzhou

Tel: 86-571-8792-8115
Fax: 86-571-8792-8116

China - Hong Kong SAR

Tel: 852-2943-5100
Fax: 852-2401-3431

China - Nanjing

Tel: 86-25-8473-2460
Fax: 86-25-8473-2470

China - Qingdao

Tel: 86-532-8502-7355
Fax: 86-532-8502-7205

China - Shanghai

Tel: 86-21-5407-5533
Fax: 86-21-5407-5066

China - Shenyang

Tel: 86-24-2334-2829
Fax: 86-24-2334-2393

China - Shenzhen

Tel: 86-755-8864-2200
Fax: 86-755-8203-1760

China - Wuhan

Tel: 86-27-5980-5300
Fax: 86-27-5980-5118

China - Xian

Tel: 86-29-8833-7252
Fax: 86-29-8833-7256

ASIA/PACIFIC

China - Xiamen

Tel: 86-592-2388138
Fax: 86-592-2388130

China - Zhuhai

Tel: 86-756-3210040
Fax: 86-756-3210049

India - Bangalore

Tel: 91-80-3090-4444
Fax: 91-80-3090-4123

India - New Delhi

Tel: 91-11-4160-8631
Fax: 91-11-4160-8632

India - Pune

Tel: 91-20-3019-1500

Japan - Osaka

Tel: 81-6-6152-7160
Fax: 81-6-6152-9310

Japan - Tokyo

Tel: 81-3-6880-3770
Fax: 81-3-6880-3771

Korea - Daegu

Tel: 82-53-744-4301
Fax: 82-53-744-4302

Korea - Seoul

Tel: 82-2-554-7200
Fax: 82-2-558-5932 or
82-2-558-5934

Malaysia - Kuala Lumpur

Tel: 60-3-6201-9857
Fax: 60-3-6201-9859

Malaysia - Penang

Tel: 60-4-227-8870
Fax: 60-4-227-4068

Philippines - Manila

Tel: 63-2-634-9065
Fax: 63-2-634-9069

Singapore

Tel: 65-6334-8870
Fax: 65-6334-8850

Taiwan - Hsin Chu

Tel: 886-3-5778-366
Fax: 886-3-5770-955

Taiwan - Kaohsiung

Tel: 886-7-213-7828

Taiwan - Taipei

Tel: 886-2-2508-8600
Fax: 886-2-2508-0102

Thailand - Bangkok

Tel: 66-2-694-1351
Fax: 66-2-694-1350

EUROPE

Austria - Wels

Tel: 43-7242-2244-39
Fax: 43-7242-2244-393

Denmark - Copenhagen

Tel: 45-4450-2828
Fax: 45-4485-2829

France - Paris

Tel: 33-1-69-53-63-20
Fax: 33-1-69-30-90-79

Germany - Dusseldorf

Tel: 49-2129-3766400

Germany - Karlsruhe

Tel: 49-721-625370

Germany - Munich

Tel: 49-89-627-144-0
Fax: 49-89-627-144-44

Italy - Milan

Tel: 39-0331-742611
Fax: 39-0331-466781

Italy - Venice

Tel: 39-049-7625286

Netherlands - Drunen

Tel: 31-416-690399
Fax: 31-416-690340

Poland - Warsaw

Tel: 48-22-3325737

Spain - Madrid

Tel: 34-91-708-08-90
Fax: 34-91-708-08-91

Sweden - Stockholm

Tel: 46-8-5090-4654

UK - Wokingham

Tel: 44-118-921-5800
Fax: 44-118-921-5820

07/14/15

X-ON Electronics

Largest Supplier of Electrical and Electronic Components

Click to view similar products for [LED Lighting Drivers](#) category:

Click to view products by [Supertex](#) manufacturer:

Other Similar products are found below :

[LV5235V-MPB-H](#) [MB39C602PNF-G-JNEFE1](#) [MIC2871YMK-T5](#) [AL1676-10BS7-13](#) [AL1676-20AS7-13](#) [AP5726WUG-7](#) [MX877RTR](#)
[ICL8201](#) [IS31BL3228B-UTLS2-TR](#) [IS31BL3506B-TTLS2-TR](#) [AL3157F-7](#) [AP5725FDCG-7](#) [AP5726FDCG-7](#) [LV52204MTTBG](#)
[AP5725WUG-7](#) [STP4CMPQTR](#) [NCL30086BDR2G](#) [CAT4004BHU2-GT3](#) [LV52207AXA-VH](#) [AP1694AS-13](#) [TLE4242EJ](#) [AS3688](#)
[IS31LT3172-GRLS4-TR](#) [TLD2311EL](#) [KTD2694EDQ-TR](#) [KTZ8864EJAA-TR](#) [IS32LT3174-GRLA3-TR](#) [ZXLD1374QESTTC](#) [MP2488DN-](#)
[LF-Z](#) [NLM0010XTSA1](#) [AL1676-20BS7-13](#) [MPQ7220GF-AEC1-P](#) [MPQ4425BGJ-AEC1-P](#) [MPQ7220GF-AEC1-Z](#) [MPQ4425BGJ-AEC1-Z](#)
[IS31FL3737B-QFLS4-TR](#) [IS31FL3239-QFLS4-TR](#) [KTD2058EUAC-TR](#) [KTD2037EWE-TR](#) [DIO5662ST6](#) [IS31BL3508A-TTLS2-TR](#)
[MAX20052CATC/V+](#) [MAX25606AUP/V+](#) [BD6586MUV-E2](#) [BD9206EFV-E2](#) [BD9416FS-E2](#) [LYT4227E](#) [LYT6079C-TL](#) [MP3394SGF-P](#)
[MP4689AGN-P](#)