



Features

- SOP package 4 Pin type in miniature design (4.4×4.3×2.1mm / .173×.169×.083inch)
- Low driver power requirements (TTL/CMOS Compatible)
- Contact form: Normally-OFF (1b)
- Load voltage: 400V max.
- On-Resistance: 50Ω max.
- 1500Vrms Input/Output isolation
- Tape & Reel version available

Applications

- Telecommunications (PC, Electronic notepad)
- Measuring and Testing equipment
- Industrial control
- Security equipments
- High speed inspection machine

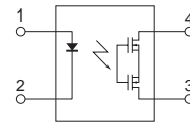

1. LED Anode
2. LED Cathode
3. Drain (MOSFET)
4. Drain (MOSFET)

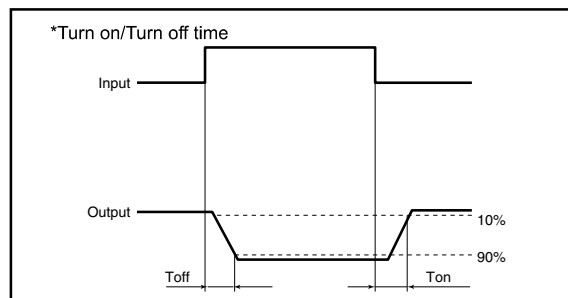

TYPES

| Category | Output rating ^{*1} | | Part No. | Packing quantity |
|----------|-----------------------------|--------------|----------|------------------|
| | Load voltage | Load current | SOP4 | Tape and reel |
| AC/DC | 400V | 120mA | GAQY414S | 2000 pcs/1REEL |

Absolute Maximum Ratings (Ambient Temperature: 25°C)

| Item | | Symbol | Value | Units | Note |
|---------------------------|--------------------------|-------------------|-------------|------------------|------------------|
| Input | Continuous LED Current | I _F | 50 | mA | |
| | Peak LED Current | I _{FP} | 500 | mA | f=100Hz, duty=1% |
| | LED Reverse Voltage | V _R | 5 | V | |
| | Input Power Dissipation | P _{In} | 75 | mW | |
| Output | Load Voltage | V _L | 400 | V(AC peak or DC) | |
| | Load Current | I _L | 120 | mA | |
| | Peak Load Current | I _{Peak} | 0.3 | A | 1ms(1 pulse) |
| | Output Power Dissipation | P _{Out} | 500 | mW | |
| Total Power Dissipation | | P _T | 550 | mW | |
| I/O Breakdown Voltage | | V _{I/O} | 1500 | V _{rms} | RH=60%, 1min |
| Operating Temperature | | T _{opr} | -40 to +85 | °C | |
| Storage Temperature | | T _{stg} | -40 to +100 | °C | |
| Pin Soldering Temperature | | T _{sol} | 260 | °C | 10 sec max. |

Electrical Specifications (Ambient Temperature: 25°C)

| Item | | Symbol | MIN. | TYP. | MAX. | Units | Conditions |
|--------------|---------------------------|-------------------|------------------|------|------|-------|--|
| Input | LED Forward Voltage | V _F | | 1.2 | 1.4 | V | I _F =10mA |
| | Operation LED Current | I _{Fon} | | 0.5 | 3.0 | mA | |
| | Recovery LED Current | I _{Foff} | | 0.35 | 0.5 | mA | |
| | Recovery LED Voltage | V _{Foff} | 0.5 | | | V | |
| Output | On-Resistance | R _{on} | | 20 | 50 | Ω | I _F =0mA, I _L =100mA, Time to flow is within 1 sec. |
| | Off-State Leakage Current | I _{Leak} | | | 10 | uA | I _F =5mA, V _L =400V |
| | Output Capacitance | C _{out} | | 165 | | pF | I _F =5mA, V _L =0, f=1MHz |
| Transmission | Turn-Off Time | T _{off} | | 0.5 | 3.0 | ms | I _F =5mA, I _L =50mA |
| | Turn-On Time | T _{on} | | 0.02 | 1.0 | ms | |
| Coupled | I/O Isolation Resistance | R _{I/O} | 10 ¹⁰ | | | Ω | DC500V |
| | I/O Capacitance | C _{I/O} | | 0.8 | | pF | f=1MHz |

Reference Data

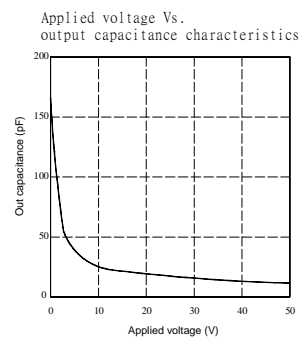
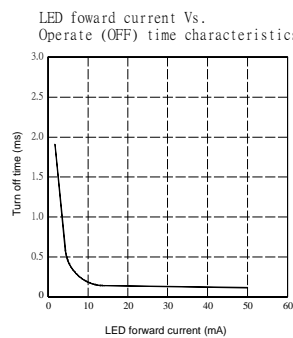
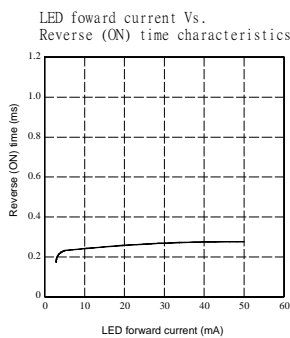
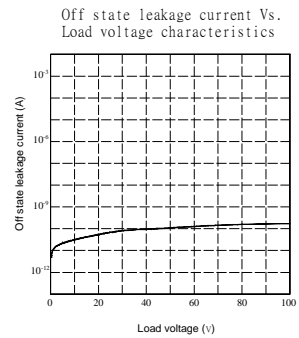
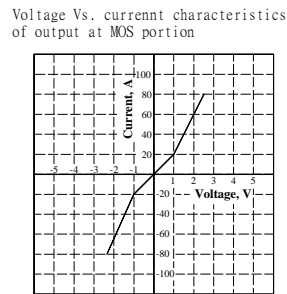
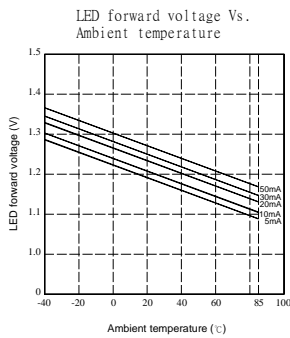
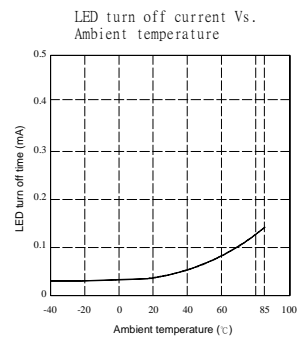
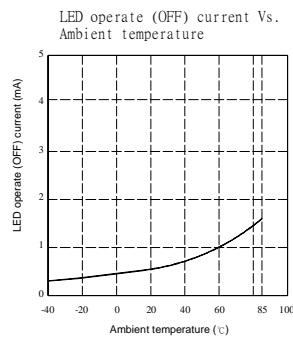
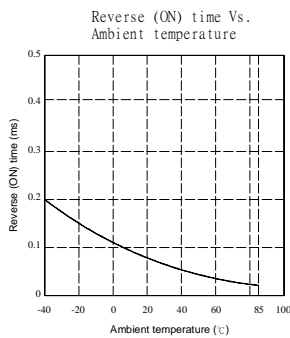
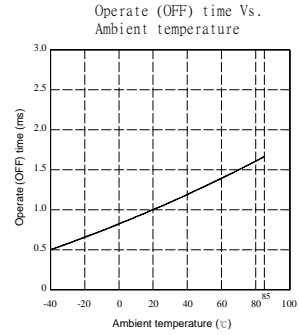
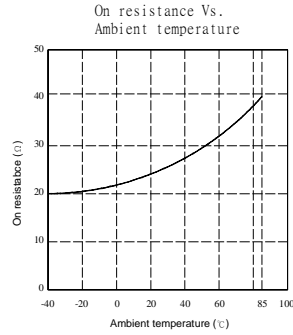
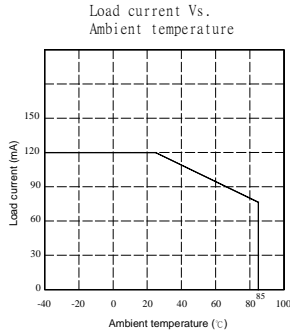

Dimensions

4-SOP

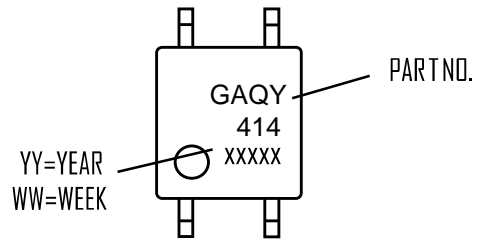

Surface mount terminal type

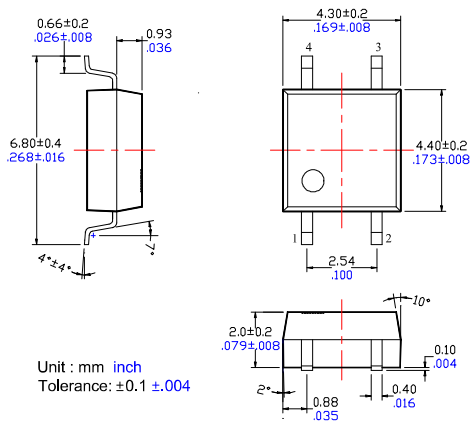

Recommended mounting pad (Top view)

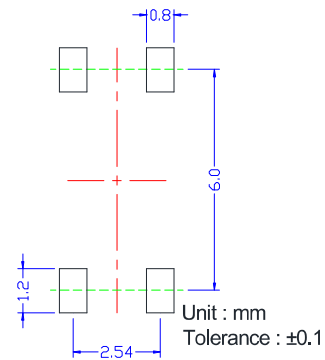

Tape dimensions

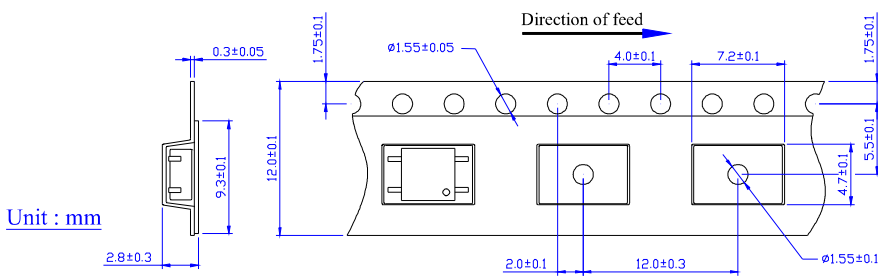

Dimensions of tape reel

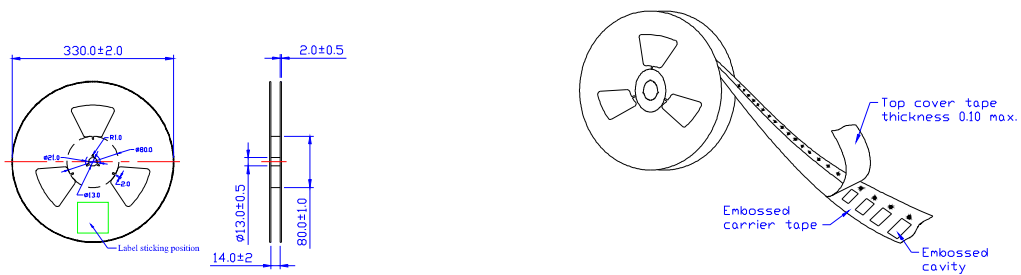

X-ON Electronics

Largest Supplier of Electrical and Electronic Components

Click to view similar products for [Solid State Relays - PCB Mount](#) category:

Click to view products by [SUPSiC](#) manufacturer:

Other Similar products are found below :

[M86F-2W](#) [M90F-2W](#) [M90F-2Y](#) [901-SX](#) [G2-1A07-ST](#) [G2-1A07-TT](#) [G2-1B02-TT](#) [G2-DA06-ST](#) [PLA134S](#) [DS11-1005](#) [AQH3213J](#)
[AQV112KLAXJ](#) [AQV210EHJ](#) [AQV212J](#) [AQV252GAJ](#) [AQY210ST](#) [AQY221N2SJ](#) [AQY221R2SJ](#) [EFR1200480A150](#) [901-7](#) [LCA220](#)
[LCB110S](#) [1618400-5](#) [SR75-1ST](#) [AQV112KLJ](#) [AQV212AJ](#) [AQV212SXJ](#) [AQV238AD01](#) [AQV252GAXJ](#) [AQW414TS](#) [AQY212ST](#)
[AQY221R2VJ](#) [AQY275AXJ](#) [AQY414SXE01](#) [G2-1A02-ST](#) [G2-1A03-ST](#) [G2-1A03-TT](#) [G2-1A05-ST](#) [G2-1A06-TT](#) [G2-1A23-TT](#) [G2-1B01-](#)
[ST](#) [G2-1B01-TT](#) [G2-1B02-ST](#) [G2-DA03-ST](#) [G2-DA03-TT](#) [G2-DA06-TT](#) [3-1617776-2](#) [CTA2425](#) [LBA110S](#) [LBB110S](#)