

SPECIFICATIONS

MECHANICAL:
 SHOCK: MIL-STD 202 METHOD 213B, COND. K.
 VIBRATION: MIL-STD 202 METHOD 201
 LIFE: 300 INSERTION/WITHDRAWAL CYCLES (MINIMUM)

ELECTRICAL
 DIELECTRIC WITHSTANDING VOLTAGE: 1,000 VAC
 INSULATION RESISTANCE: 100 MEGOHMS (MIN) AT 77°F
 CONTACT RESISTANCE: 5.0 MILLOHMS MAX.
 CURRENT RATING: 7.5 AMPS (#20 CONTACT)
 13.0 AMPS (#16 CONTACT)

ENVIRONMENTAL
 TEMPERATURE LIMITS: -40°C TO +65°C (NON-OPERATING)
 MOISTURE RESISTANCE: MIL-STD 202 METHOD 106F
 INSULATION RESISTANCE: MIL-STD 202 METHOD 302, COND. B
 THERMAL SHOCK: MIL-STD 202 METHOD 107G
 SALT SPRAY: MIL-STD 202 METHOD 101D, COND. B
 WATER TIGHTNESS TEST: U.S. COAST GUARD CFR 46 PART 110.20

MATERIALS:
 CORD CONNECTOR SHELL, CONTACT
 LOCKING DISK, COUPLING RING AND CABLE CLAMP
ASSEMBLY:
 THERMOPLASTIC POLYMER GLASS FIBER, FLAME RETARDANT

REAR BOOT AND CONNECTOR SHELL INTERIOR:
 THERMOPLASTIC RUBBER

CONTACTS: COPPER BASE ALLOY GOLD-PLATED
 OVER NICKEL UNDERPLATE

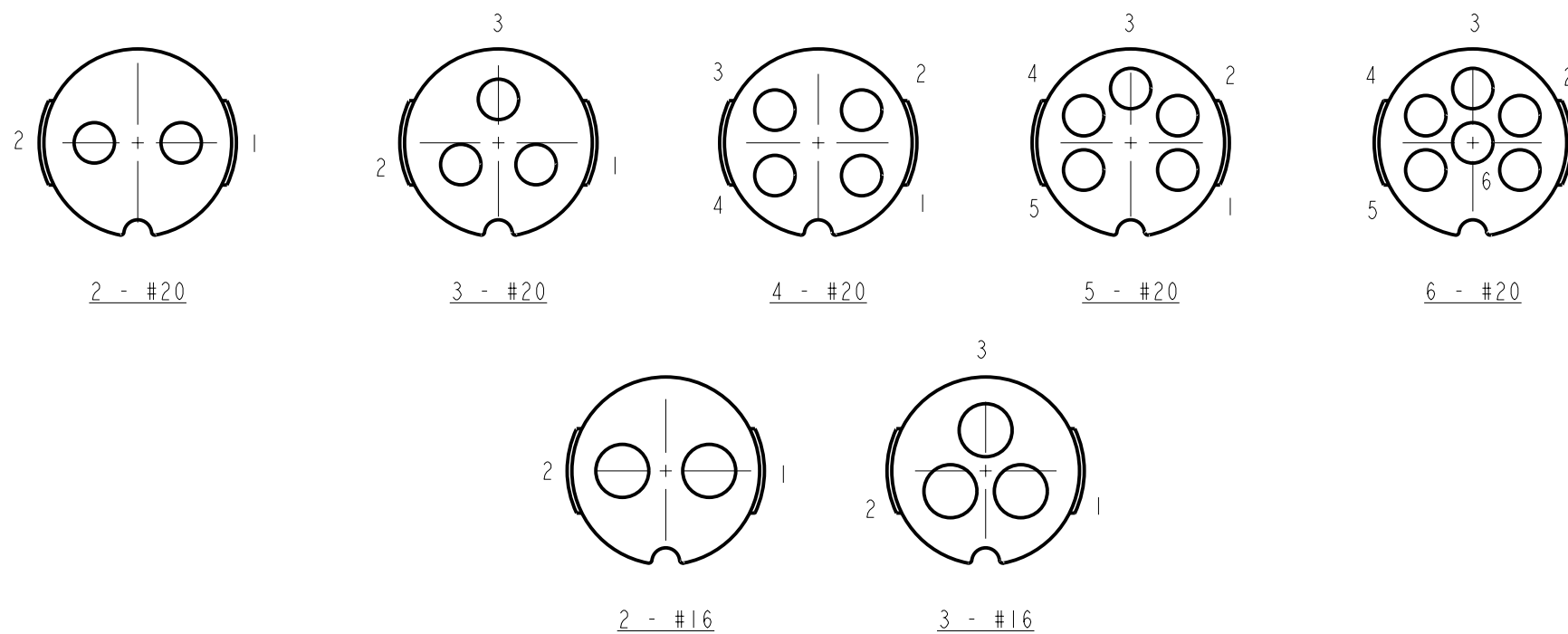

CONTACT ARRANGEMENTS

SHOWN ARE REAR VIEWS OF MALE CORD CONNECTORS

NOTE: #7 AND #8 PIN NOT AVAILABLE IN MALE CORD CONNECTOR.

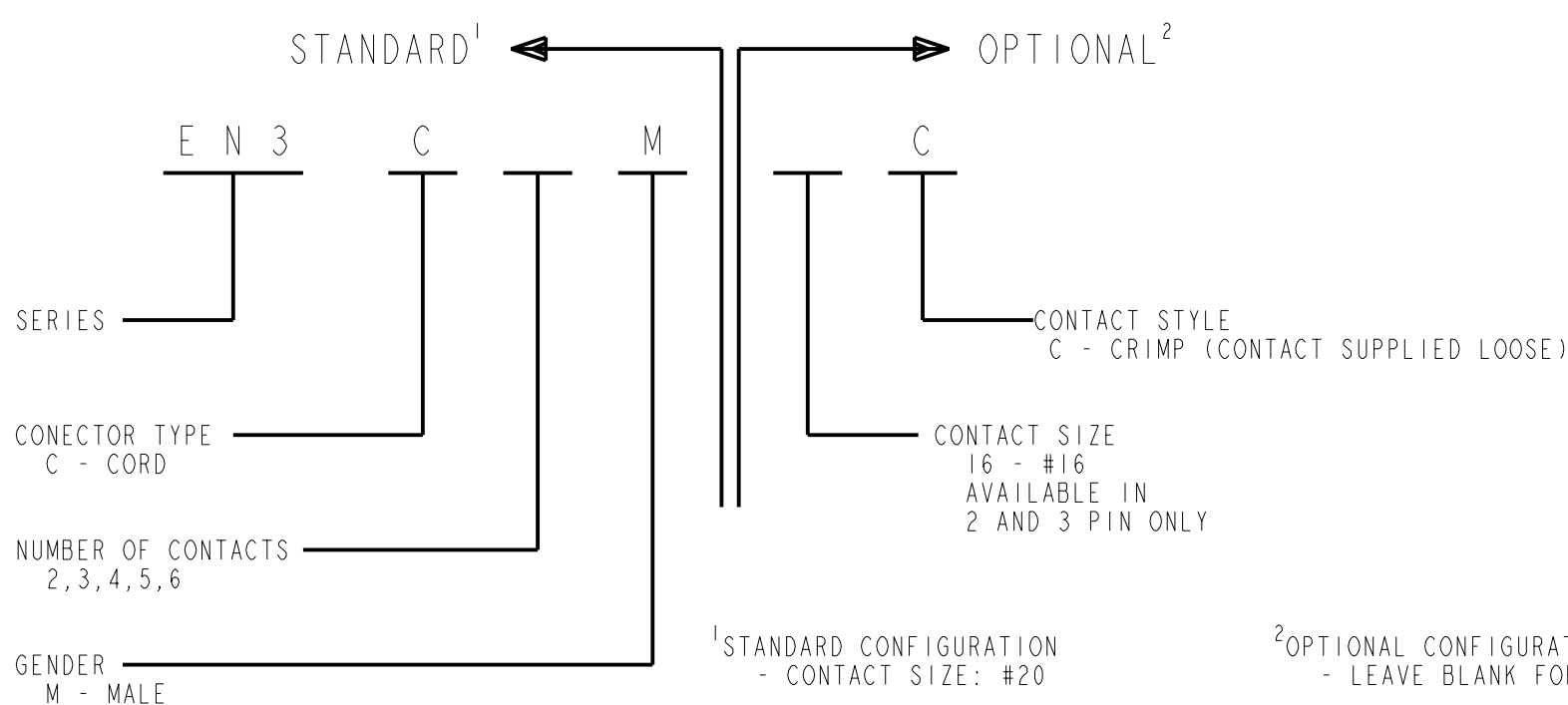
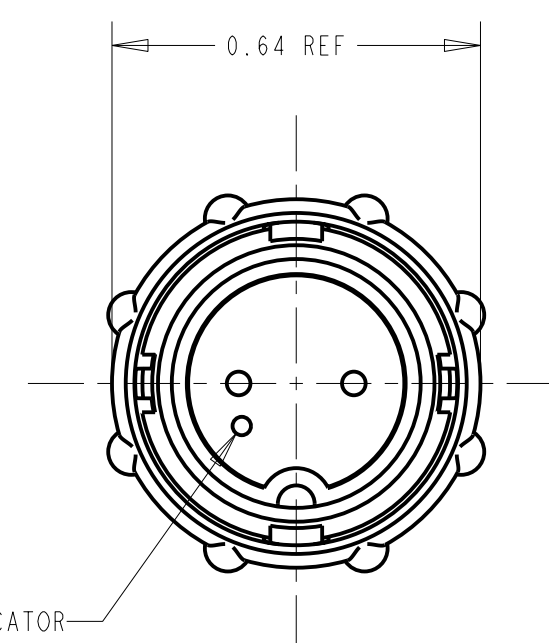
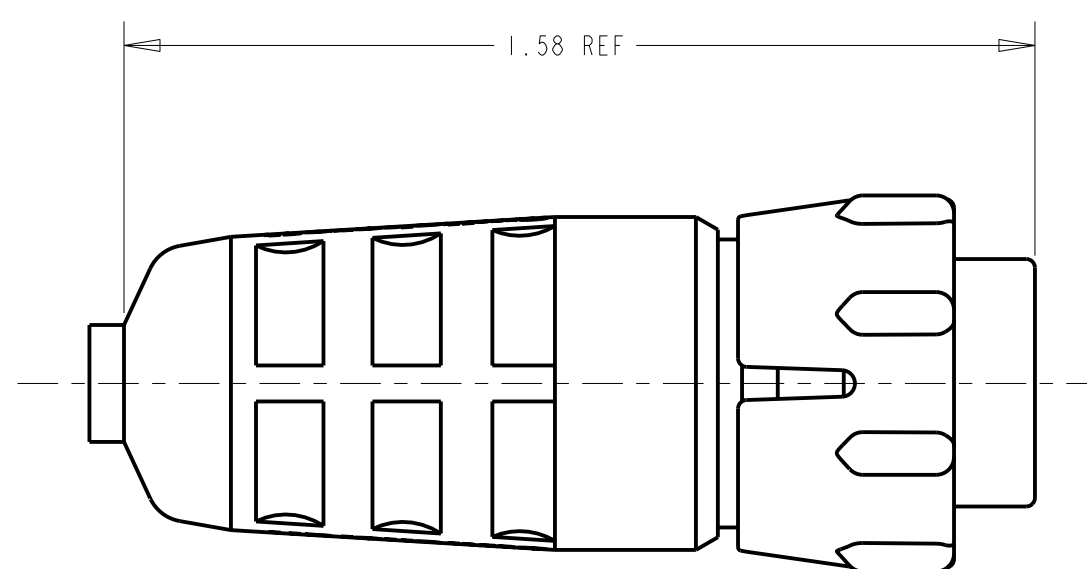
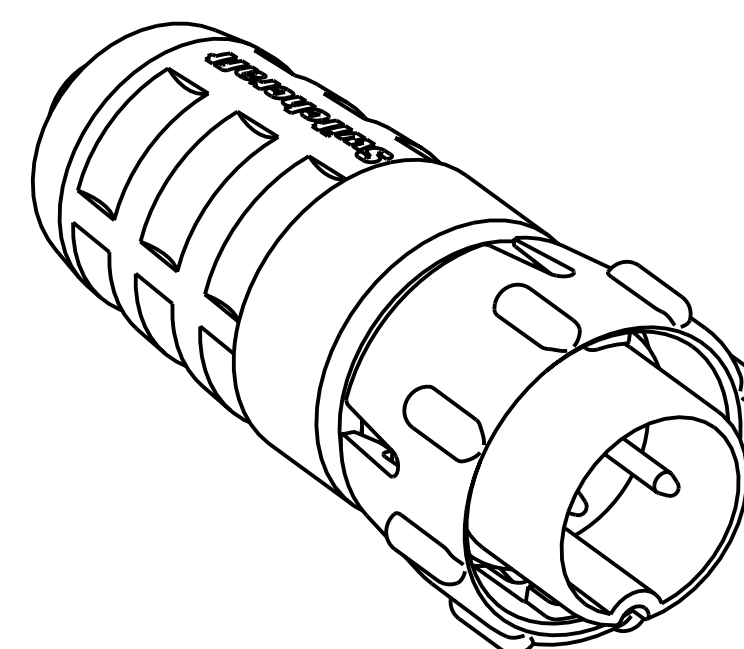
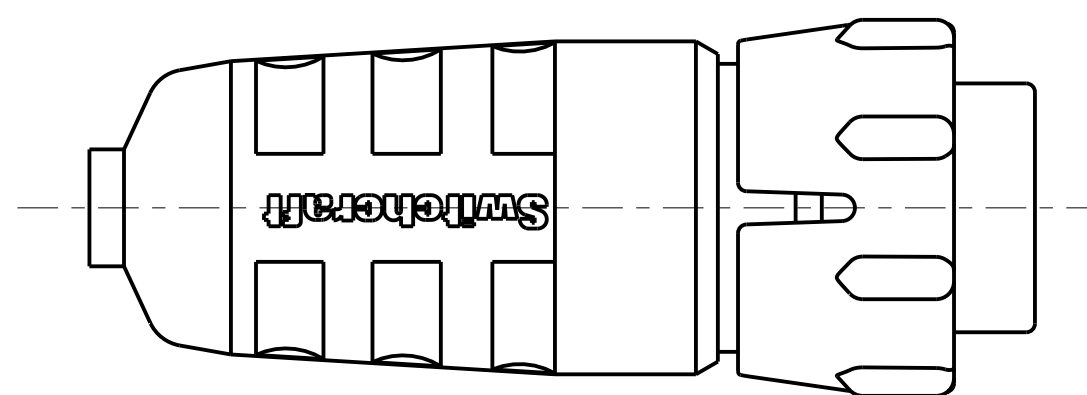

¹STANDARD CONFIGURATION
 - CONTACT SIZE: #20
 - CONTACT STYLE: SOLDER CUP
 - CONTACT PLATING: GOLD
 - PACKAGED IN BULK

²OPTIONAL CONFIGURATION
 - LEAVE BLANK FOR STANDARD CONFIGURATION

REV	ECO NUMBER	DATE	BY	APVD
D	22232	6-12-98	SG	RB
C	21282	1-31-97	SG	RB
B	20897	1-31-97	SG	RB
A	RELEASE TO MFG ECO #20698	4-2-96	CCB	RB

★ STAR SYMBOL DENOTES CRITICAL DIMENSION

UNLESS OTHERWISE SPECIFIED

1. ALL DIMENSIONS IN INCHES
 - TWO PLACE DECIMALS ±0.01
 - THREE PLACE DECIMALS ±0.005
 - ANGLES ±1°
 - ALL DIA. CONCENTRIC WITHIN 0.005 T.I.R.

2. FEATURES ON THE SAME CENTERLINE MUST BE ALIGNED WITHIN ±0.002

3. REMOVE ALL BURRS

DO NOT SCALE DRAWING

THIS DRAWING DESCRIBES A DESIGN CONSIDERED PROPRIETARY IN NATURE, DEVELOPED AND MANUFACTURED BY SWITCHCRAFT INC. AND IS RELEASED ON A CONFIDENTIAL BASIS FOR IDENTIFICATION PURPOSES ONLY.				
SIZE	WIDTH	MULT	LBS/M	TEMPER
FINISH		MATERIAL		
SPEC No.		SPEC No.		
FIRST USED ON		SCALE		
		3:1		
DATE DRAWN	BY	CHKD	APVD	
11-28-95	SG	11-28-95	RB	
NAME		PART No.		
MALE CORD CONNECTOR		EN3C_M_C		
				REV
				D

CUSTOMER DRAWING



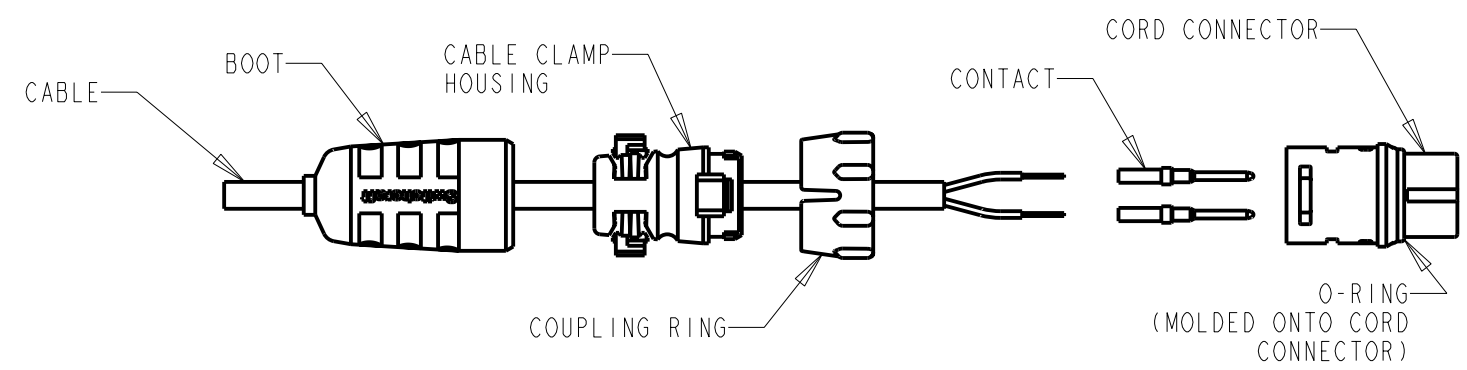

STEP 1
 STRIP CABLE AS SHOWN.
 FEED THE END OF THE CABLE THROUGH THE BOOT, CABLE CLAMP HOUSING, AND COUPLING RING IN THE ORDER AND POSITION SHOWN.
 CRIMP CONDUCTOR TO CONTACT.
 CONTACT #1 TO BE NEXT TO NOTCH.

**REMAINING CONTACTS TO BE PLACED COUNTER CLOCKWISE.

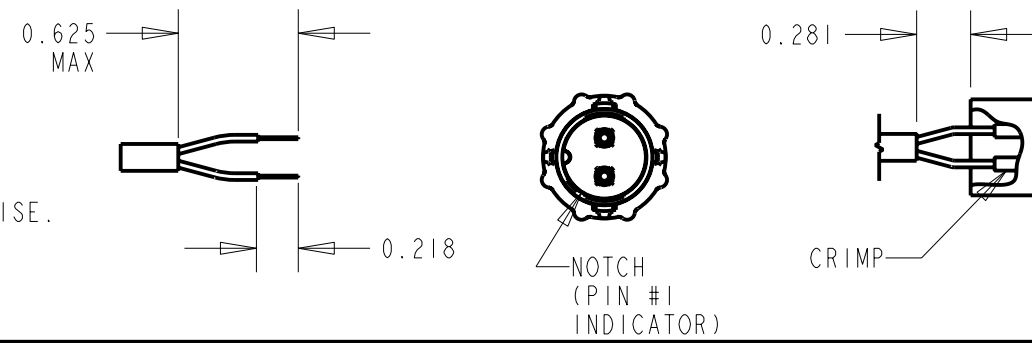

STEP 2
 ALIGN COUPLING RING'S TABS WITH CORD CONNECTOR'S SIDE NOTCHES AND PUSH THE COUPLING RING ONTO CORD CONNECTOR.

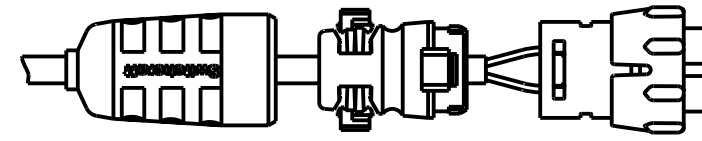

STEP 3
 PUSH THE CABLE CLAMP HOUSING FORWARD UNTIL IT LOCKS INTO THE CONNECTOR BODY AND SNAP THE TWO CLAMPS INTO IT'S COMPARTMENTS.

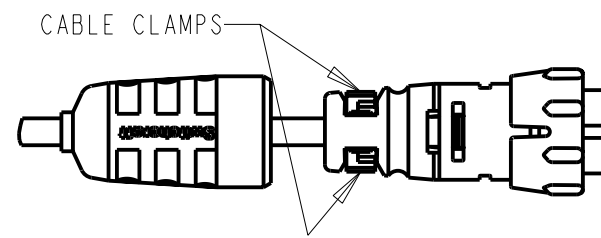

STEP 4
 PUSH THE BOOT ALL THE WAY FORWARD TO SEAT TIGHTLY ONTO THE CABLE CLAMP HOUSING.

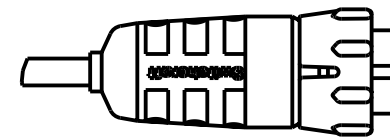

CONTACT INSERTION INSTRUCTIONS

HOUSING NOT SHOWN

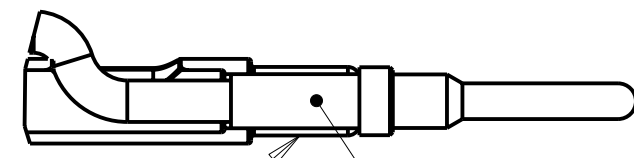

PLACE CRIMP CONTACT AND CONDUCTOR ONTO HAND TOOL.

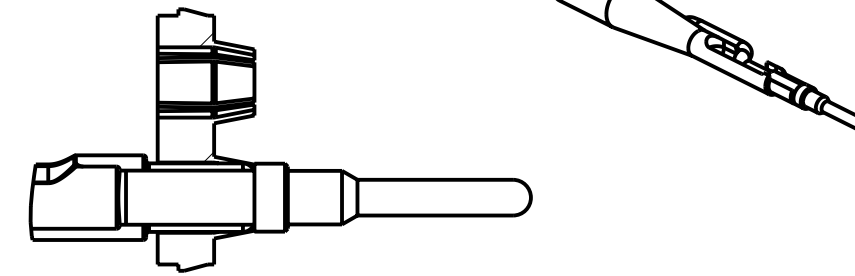

INSERT TOOL INTO HOUSING UNTIL IT BOTTOMS ONTO DISC.

CONTACT EXTRACTION INSTRUCTIONS

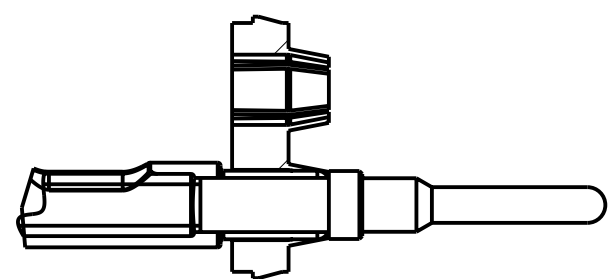

INSERT TOOL INTO HOUSING UNTIL IT BOTTOMS ONTO DISC.

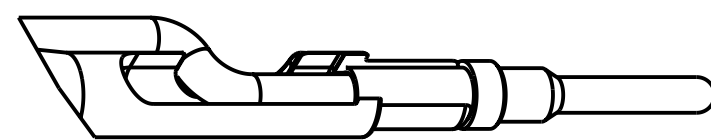

PLACE CONDUCTOR INTO SLOT ON HAND TOOL AS SHOWN.

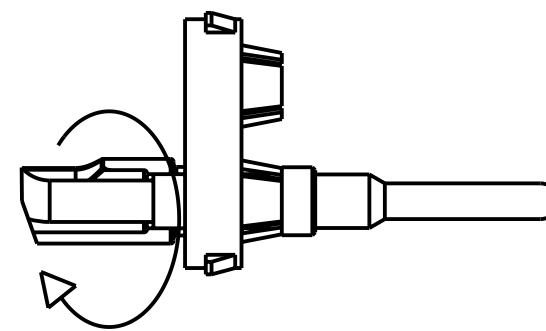

ROTATE HAND TOOL CLOCKWISE AND REMOVE FROM HOUSING.

EN3 CRIMP TOOL

SWITCHCRAFT PART NUMBER	DESCRIPTION	CONTACT SIZE	MANUFACTURER PART NUMBER	MILITARY PART NUMBER
EN3CR	CRIMP HAND TOOL FRAME	#20, #16	DMC MH860	M22520/7-01
EN3CRAUTO	POWER CRIMP TOOL	#20, #16	DMC WA22P	
EN3POS20	POSITIONER	#20	DMC 86-15	M22520/7-02
EN3POS16	POSITIONER	#16	DMC 86-3	M22520/7-04

CONTACT PART NO.	CONTACT SIZE	DIM. "A"	DIM. "B"	DIM. "C"	DIM. "D"	WIRE GAUGE RANGE	INSERTION/ EXTRACTION HAND TOOL
EN3CC20M	#20	0.209	0.047	0.069	0.041	#20-22-24	EN3INS20
EN3CC16M	#16	0.218	0.067	0.095	0.062	#16-18-20	EN3IN16

RECOMMENDED STRIP LENGTH: 0.218

ALL DIMENSIONS ARE REFERENCE UNLESS OTHERWISE SPECIFIED

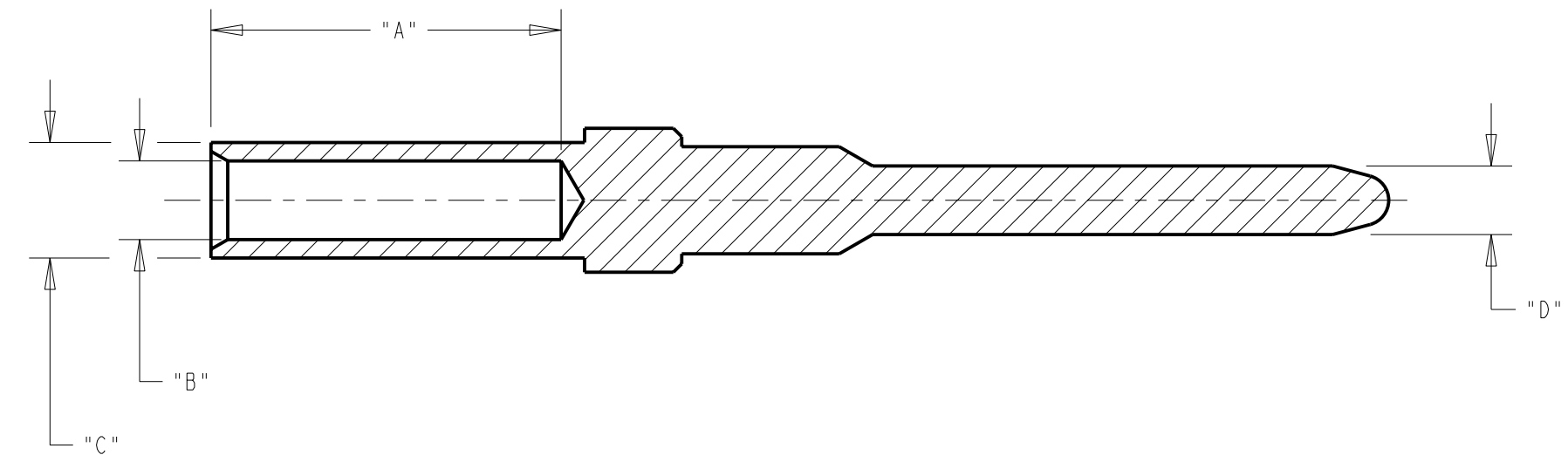

CUSTOMER DRAWING

SCALE 3:1	Switchcraft®	
DATE DRAWN 15-Apr-96		
DRAWN BY CCB	PART No. EN3C_M_C	REV D

X-ON Electronics

Largest Supplier of Electrical and Electronic Components

Click to view similar products for [Standard Circular Connector](#) category:

Click to view products by [Switchcraft](#) manufacturer:

Other Similar products are found below :

[5M2530B10P](#) [600259N006](#) [600273N007](#) [6134-336-13149](#) [6134-337-11149](#) [6134-337-2390](#) [6134-341-17149](#) [6280-4SG-516](#) [6280-7SG-3DC](#)
[6290](#) [6291A](#) [66200A-10](#) [680-SMG](#) [681-PMG](#) [CXS3102A14S2P](#) [CXS3102A181S](#) [7251-5SG-300](#) [7271-6SG-300](#) [7282-3PG-300-CH3](#) [75-](#)
[474618-01S](#) [75-474618-04P](#) [75-474618-04S](#) [799539-000](#) [MI8-SE](#) [805-005-07NF11-19PC](#) [805-005-07NF15-7PA](#) [8280-4PG-516](#) [8280-7PG-](#)
[519](#) [8282-5PG-519](#) [836783-1](#) [MP-4102-25P-C](#) [862256-1](#) [864019-2](#) [866857-1](#) [867865-1](#) [PT01SP-14-18P](#) [PT08P-14-5S](#) [PTSF06SE-14-12S](#)
[120-1833-000](#) [QCM019PC2DC012B](#) [1-2069279-1](#) [121583-0217](#) [121667-0020](#) [129591AU](#) [1000B BULK](#) [RD10A16-19-P6CS051/1](#)
[RD10A20-31-P8CS051/1](#) [RD16A14-12-S6CS051/2](#) [1301240290](#) [1301240347](#) [1301860202](#)