



TAI-SAW TECHNOLOGY CO., LTD.

No. 3, Industrial 2nd Rd., Ping-Chen Industrial District,
Taoyuan, 324, Taiwan, R.O.C.

TEL: 886-3-4690038 FAX: 886-3-4697532

E-mail: tstsales@mail.taisaw.com Web: www.taisaw.com

Product Specifications Approval Sheet

Product Name: SAW Filter 1583 MHz (BW 46.79MHz) SMD 1.4X1.1 mm

TST Parts No.: TA1661A

Customer Parts No.: _____

Company: _____
Division: _____
Approved by : _____
Date: _____

Checked by: _____ Michael Yang *Michael*

Approval by: _____ Kazuma Lee *Kazuma Lee*

Date: _____ 2022/02/11

1. Customer signed back is required before TST can proceed with sample build and receive orders.
2. Orders received without customer signed back will be regarded as agreement on the specifications.
3. Any specifications changes must be approved upon by both parties and a new revision of specifications shall be released to reflect the changes



TAI-SAW TECHNOLOGY CO., LTD.

No. 3, Industrial 2nd Rd., Ping-Chen Industrial District,
Taoyuan, 324, Taiwan, R.O.C.

TEL: 886-3-4690038 FAX: 886-3-4697532

E-mail: tstsales@mail.taisaw.com Web: www.taisaw.com

SAW Filter 1583MHz

MODEL NO.:TA1661A

REV. NO.:6.0

A. MAXIMUM RATING:

1. Input Power Level: 15 dBm
2. DC Voltage : 5Vmax
3. Operating Temperature: -40°C to +85°C
4. Storage Temperature: -40°C to +105°C
5. Moisture Sensitivity Level: Level 2a (MSL2a)
6. ESD 50V(MM) 100V(HBM)

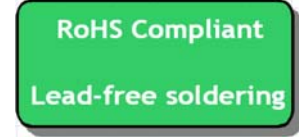

Electrostatic Sensitive Device (ESD)

B. ELECTRICAL CHARACTERISTICS:

Terminating source impedance (single) : $Z_s = 50 \Omega$

Terminating load impedance(single) : $Z_L = 50 \Omega$

Item	Unit	Min	Type.	Max
Center Frequency Fc	MHz	-	1583	-
Insertion Loss (1559.1~1563.1 MHz) IL	dB		1.8	2.1
Insertion Loss (1573.42~1577.42 MHz) IL	dB		1.4	1.6
Insertion Loss (1597.55~1605.89 MHz) IL	dB		1.7	2.1
VSWR (1559.1~1563.1 MHz)			1.4	1.8
VSWR (1573.42~1577.42 MHz)			1.6	2.0
VSWR (1597.55~1605.89 MHz)			1.6	1.9
Absolute Group Delay (1573.42~1577.42 MHz)	nS		15	17
Absolute Group Delay (1597.55~1605.89 MHz)	nS		17	19
Group Delay Ripple (1573.42~1577.42 MHz)	nS		2	3
Group Delay Ripple (1597.55~1605.89 MHz)	nS		4	6
Amplitude ripple				
(1559.1~1563.1 MHz)	dB		0.6	0.8
(1573.42~1577.42 MHz)	dB		0.3	0.5
(1597.55~1605.89 MHz)	dB		0.5	0.6
Attenuation				
100 ~ 824 MHz	dB	40	46	
824 ~ 925 MHz	dB	40	46	

1427 ~ 1463 MHz	dB	40	45	
1710 ~ 1785 MHz	dB	36	40	
1850 ~ 1980 MHz	dB	36	40	
2400 ~ 2570 MHz	dB	36	40	
2570 ~ 3000 MHz	dB	33	40	
Package size	mm	1411		

C. OUTLINE DRAWING:

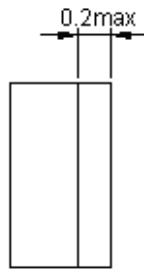
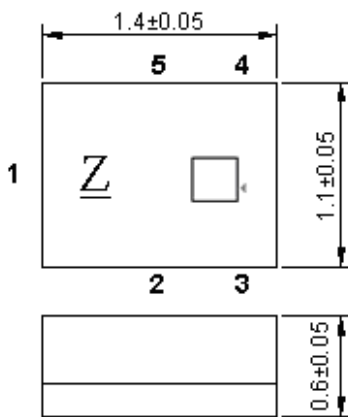

All tolerances are +/-0.05 mm unless otherwise specified
 Coplanarity : 0.1 mm max.
 1 to 5 : Pin No.
 Unit : mm

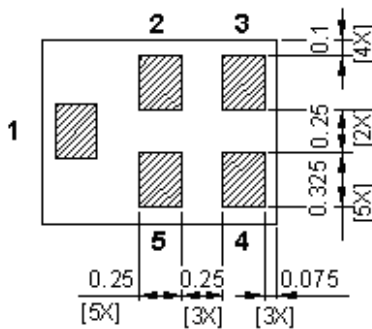

Pin No.Ⓢ	SymbolⓈ	FunctionⓈ
1Ⓢ	INⓈ	InputⓈ
2Ⓢ	GNDⓈ	GroundⓈ
3Ⓢ	GNDⓈ	GroundⓈ
4Ⓢ	OUTⓈ	OutputⓈ
5Ⓢ	GNDⓈ	GroundⓈ

□ : Year/Month Code (Follow the table) - 8year cycle

YEAR/Month	1	2	3	4	5	6	7	8	9	10	11	12
2021	A	B	C	D	E	F	G	H	J	K	L	M
2022	N	P	Q	R	S	T	U	V	W	X	Y	Z
2023	a	b	c	d	e	f	g	h	j	k	l	m
2024	n	p	q	r	s	t	u	v	w	x	y	z
2025	<u>A</u>	<u>B</u>	<u>C</u>	<u>D</u>	<u>E</u>	<u>F</u>	<u>G</u>	<u>H</u>	<u>J</u>	<u>K</u>	<u>L</u>	<u>M</u>
2026	<u>N</u>	<u>P</u>	<u>Q</u>	<u>R</u>	<u>S</u>	<u>T</u>	<u>U</u>	<u>V</u>	<u>W</u>	<u>X</u>	<u>Y</u>	<u>Z</u>
2027	<u>a</u>	<u>b</u>	<u>c</u>	<u>d</u>	<u>e</u>	<u>f</u>	<u>g</u>	<u>h</u>	<u>i</u>	<u>k</u>	<u>l</u>	<u>m</u>
2028	<u>n</u>	<u>p</u>	<u>q</u>	<u>r</u>	<u>s</u>	<u>t</u>	<u>u</u>	<u>v</u>	<u>w</u>	<u>x</u>	<u>y</u>	<u>z</u>

D. Frequency Characteristics:

S21 response: (span 500MHz)

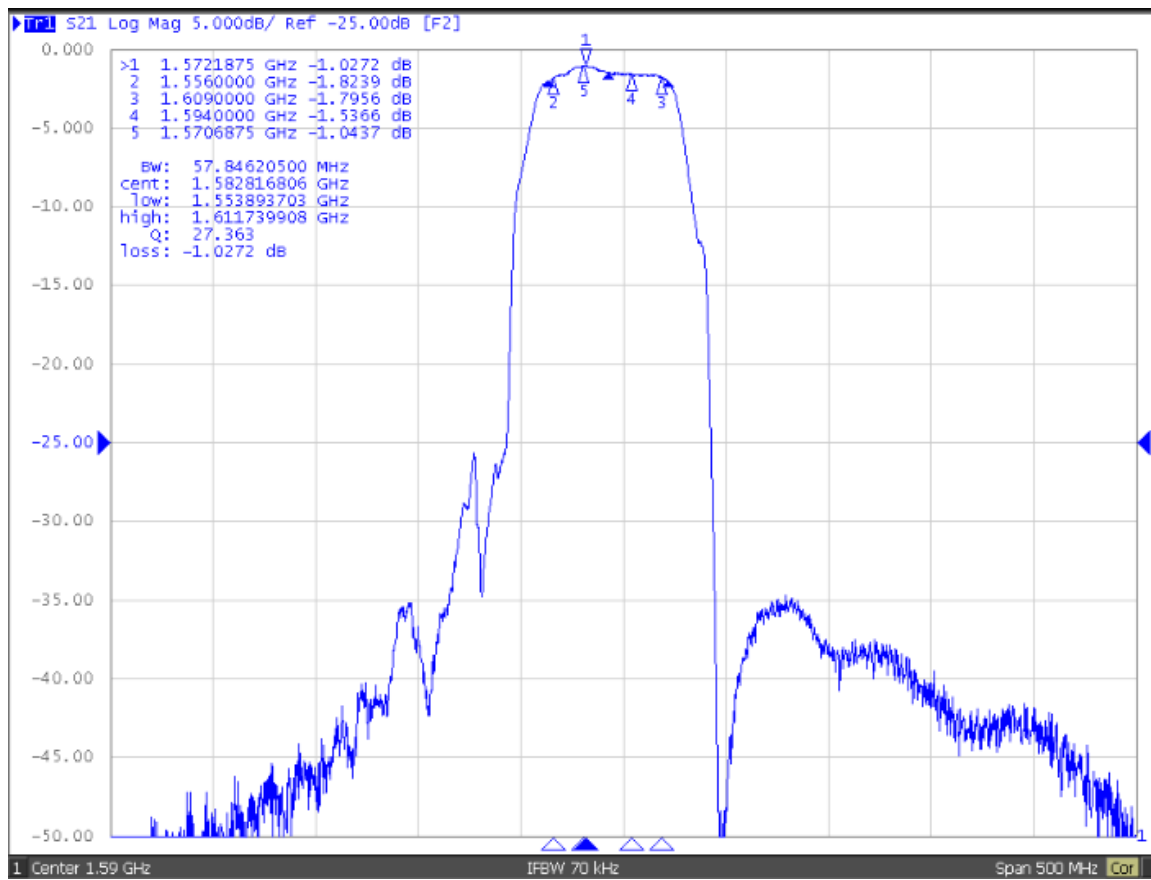

S21 response: (span 100MHz)

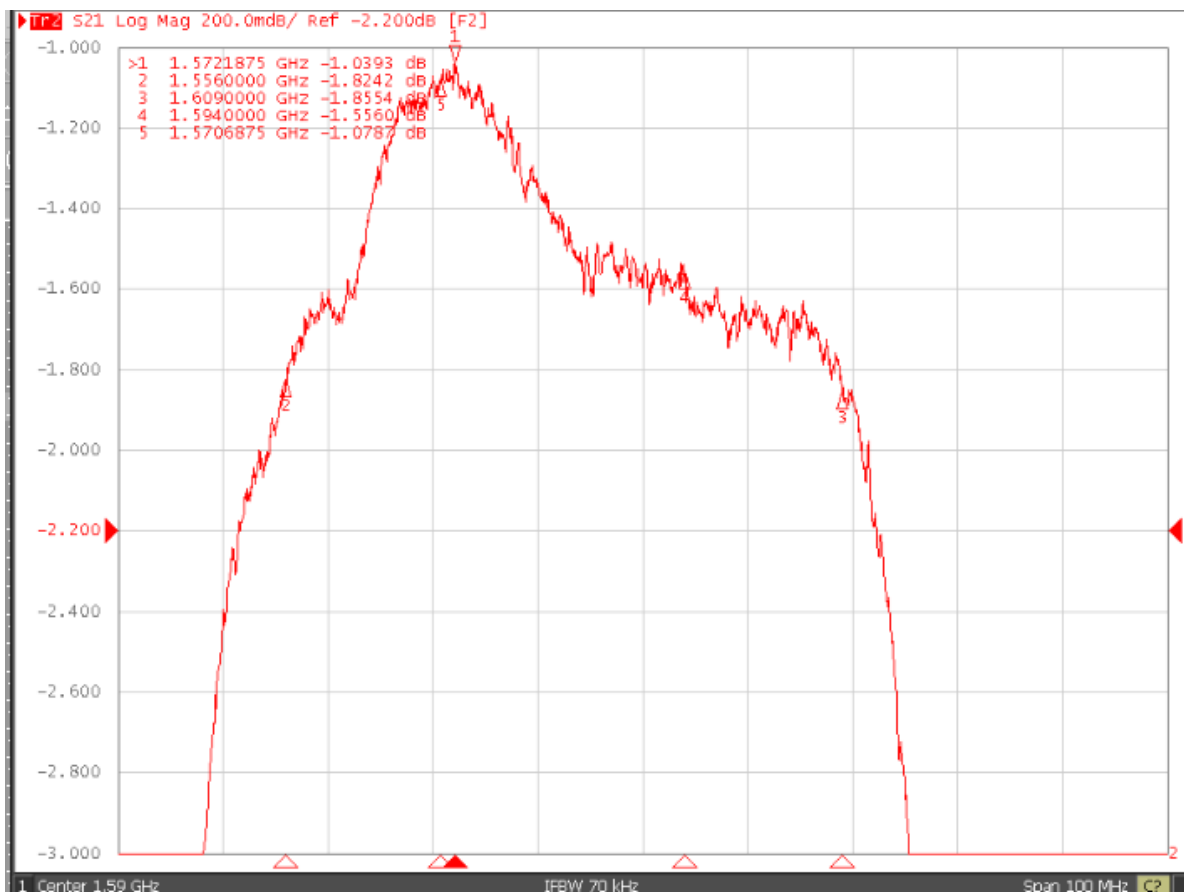

Delay :

TA1661A-Delay

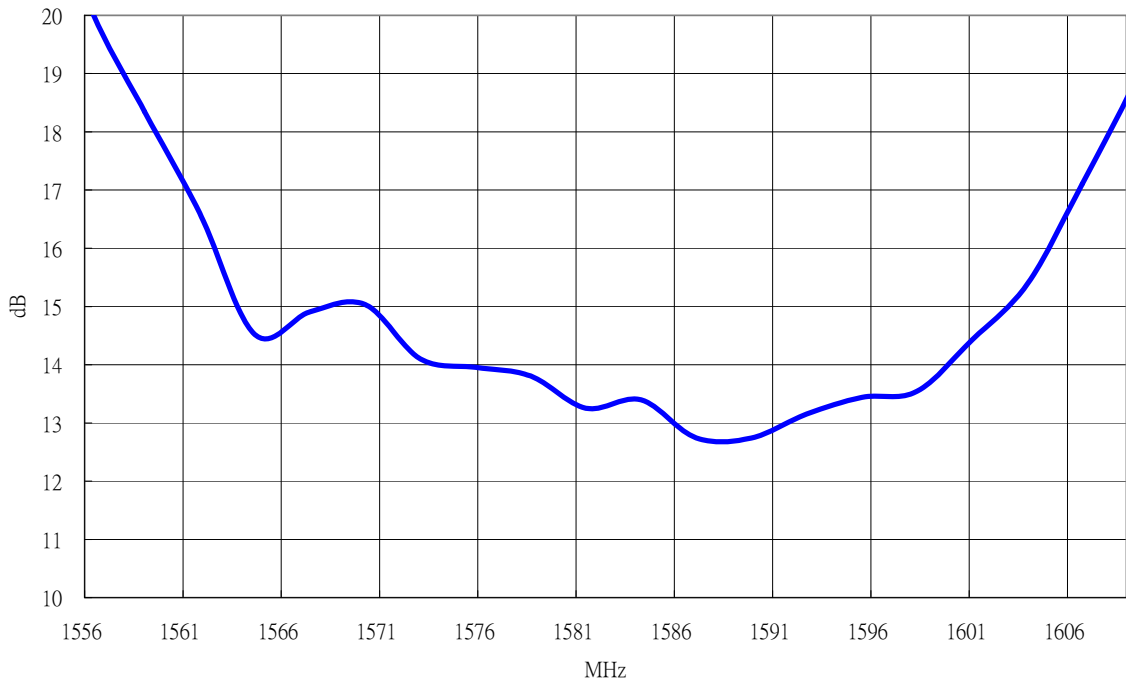

S11/S22 response :

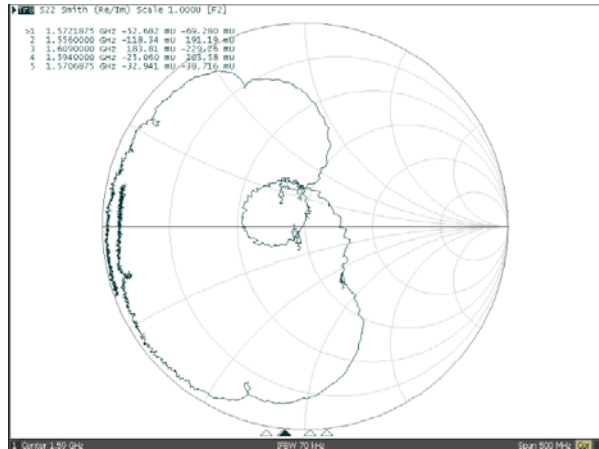
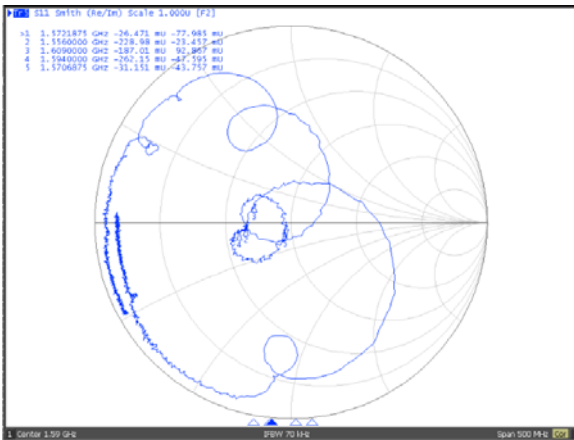

S21 response: (span 3GHz)

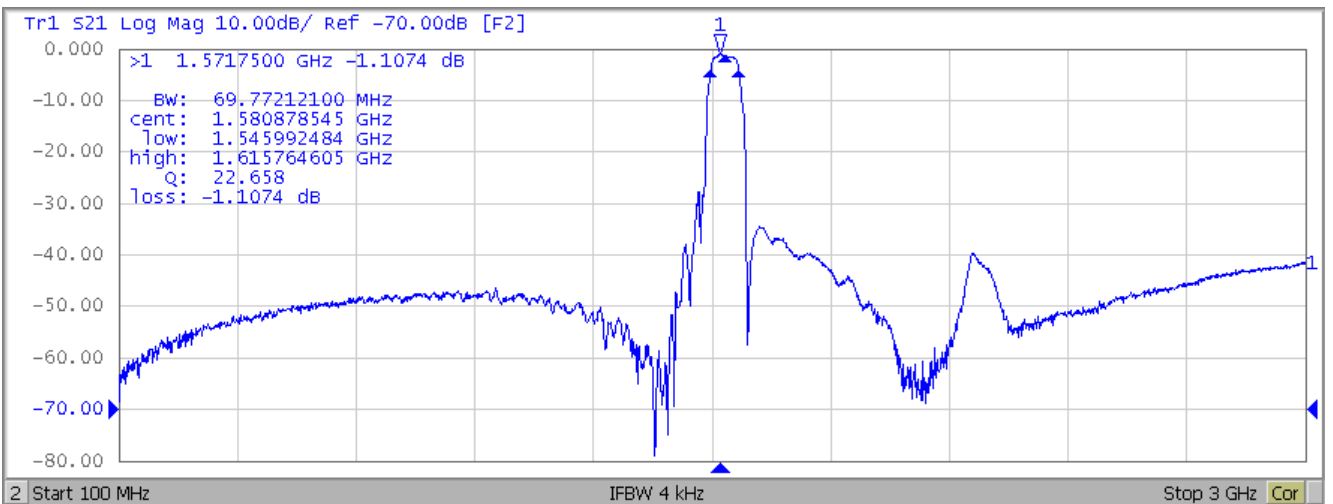

E. MEASUREMENT CIRCUIT:

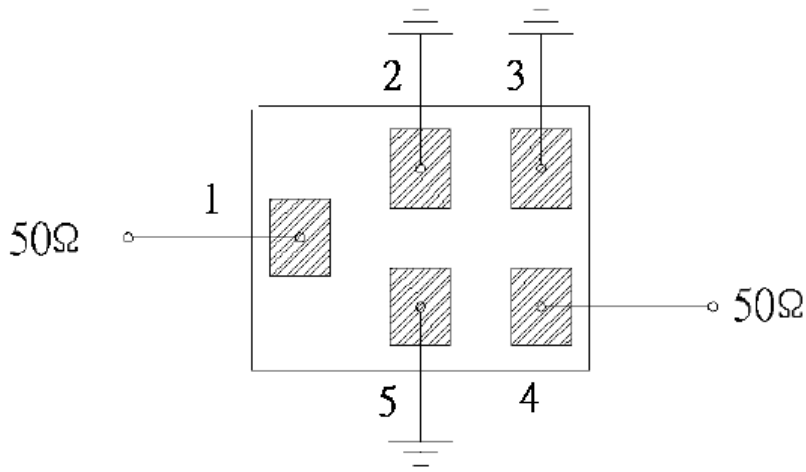

F. PCB Footprint:

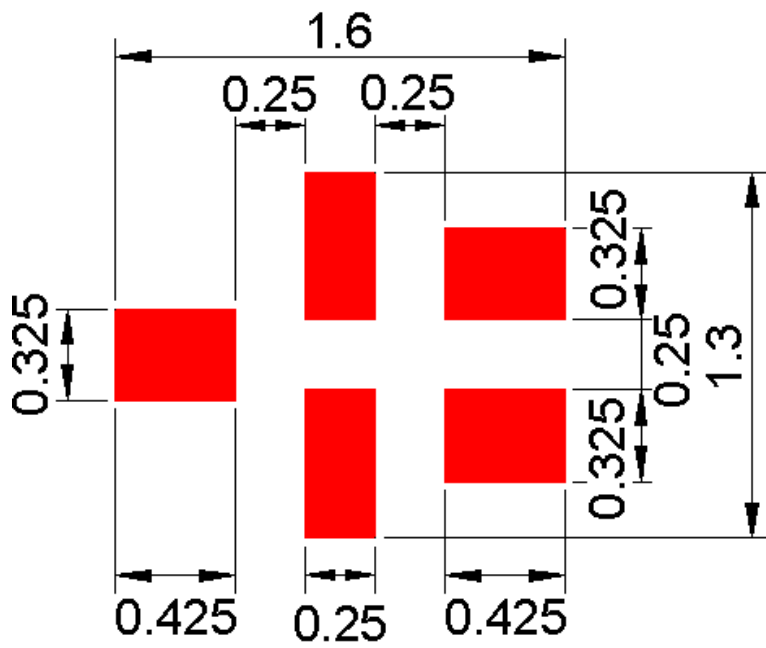

 : Land Pattern
Unit: mm

G. PACKING:

1. REEL DIMENSION

(Please refer to FR-75D10 for packing quantity)

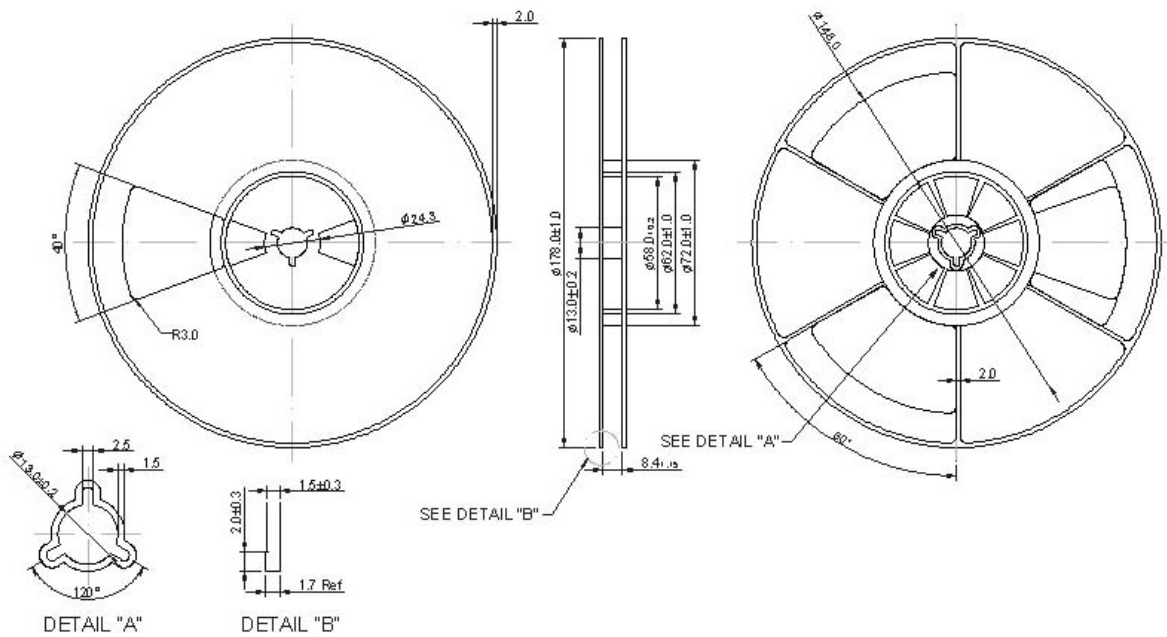

2. TAPE DIMENSION

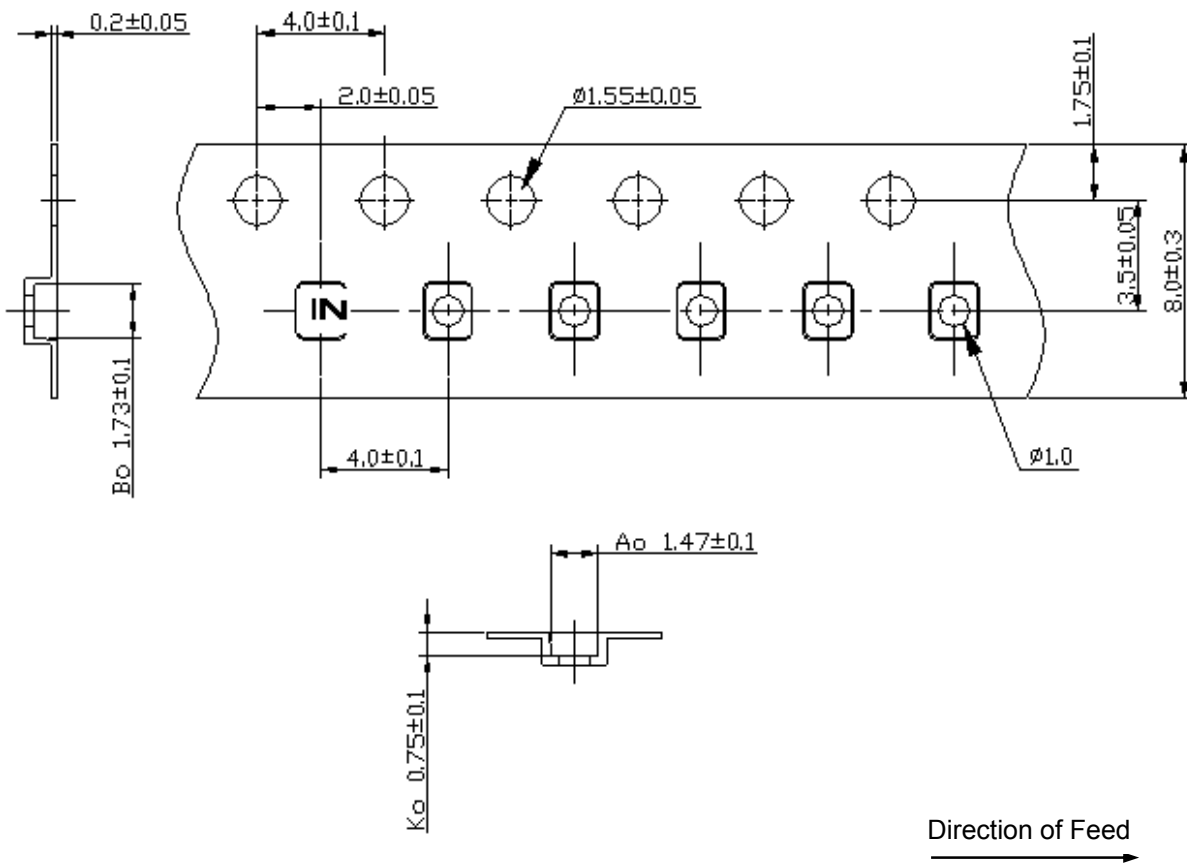

H. Recommended Reflow Profile:

1. Preheating shall be fixed at 150~180°C for 60~90 seconds.
2. Ascending time to preheating temperature 150°C shall be 30 seconds min.
3. Heating shall be fixed at 220°C for 50~80 seconds and at 260°C +0/-5°C peak (20~40sec).
4. Time: 2 times.

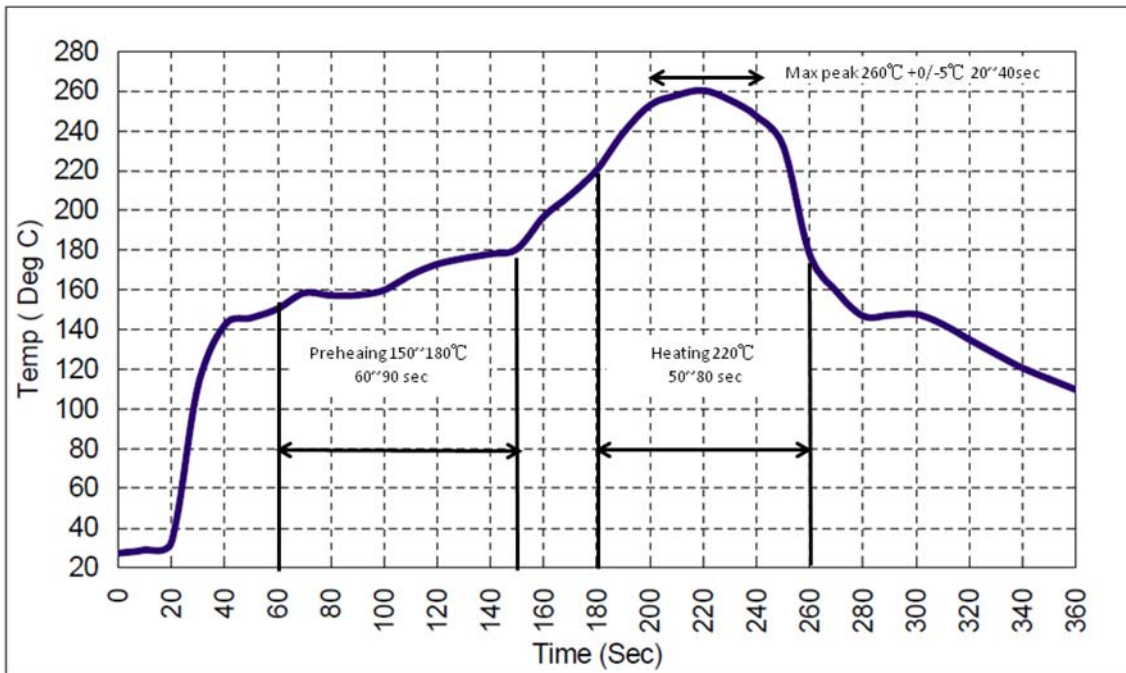

X-ON Electronics

Largest Supplier of Electrical and Electronic Components

Click to view similar products for [Signal Conditioning](#) category:

Click to view products by [Tai-Saw Technology](#) manufacturer:

Other Similar products are found below :

[MAPDCC0001](#) [MAPDCC0004](#) [PD0409J5050S2HF](#) [HHS-109-PIN](#) [AFS14A35-1591.50-T3](#) [DS-323-PIN](#) [JP510S](#) [LFB322G45SN1A504](#)
[SF2159E](#) [FM-104-PIN](#) [CER0813B](#) [MAPDCC0005](#) [3A325](#) [BD0810N50100AHF](#) [JHS-115-PIN](#) [DC0710J5005AHF](#) [DC2327J5005AHF](#)
[LFB2H2G60BB1C106](#) [LFL15869MTC1B787](#) [X3C19F1-20S](#) [XC3500P-20S](#) [CDBLB455KCAX39-B0](#) [RF1353C](#) [051157-0000](#)
[PD0922J5050D2HF](#) [600S150FTRB](#) [1E1305-3](#) [1F1304-3S](#) [1G1304-30](#) [TP-103-PIN](#) [BD1222J50200AHF](#) [BD1722J50100AHF](#)
[2450DP39K5400E](#) [BD0810J50150AHF](#) [BD1722J50200AHF](#) [DSS-113-PIN](#) [DS-327-PIN](#) [MACP-008125-CK07F0](#) [DS-329-PIN](#) [DS-313-PIN](#)
[M38510/10304BCA](#) [TP-104-PIN](#) [HH-128-PIN](#) [JP506S](#) [XC0900P-10S](#) [XC0900B-30S](#) [CHS-134-PIN](#) [CHE1260-QAG](#) [11305-10](#) [5962-](#)
[9091202MXA](#)