



TAI-SAW TECHNOLOGY CO., LTD.

No. 3, Industrial 2nd Rd., Ping-Chen Industrial District,
Taoyuan, 324, Taiwan, R.O.C.

TEL: 886-3-4690038 FAX: 886-3-4697532

E-mail: tstsales@mail.taisaw.com Web: www.taisaw.com

Product Specifications Approval Sheet

Product Name: SAW Filter 1583 MHz (BW 46.79MHz) SMD 2.0X1.6 mm

TST Parts No.: TA1745A

Customer Parts No.: _____

Company: _____
Division: _____
Approved by : _____
Date: _____

Checked by: _____ Michael Yang *Michael*

Approval by: _____ Bob Chau *Bob Chau*

Date: _____ 2014/07/17

1. Customer signed back is required before TST can proceed with sample build and receive orders.
2. Orders received without customer signed back will be regarded as agreement on the specifications.
3. Any specifications changes must be approved upon by both parties and a new revision of specifications shall be released to reflect the changes



TAI-SAW TECHNOLOGY CO., LTD.

No. 3, Industrial 2nd Rd., Ping-Chen Industrial District,
Taoyuan, 324, Taiwan, R.O.C.

TEL: 886-3-4690038 FAX: 886-3-4697532

E-mail: tstsales@mail.taisaw.com Web: www.taisaw.com

SAW Filter 1583MHz

MODEL NO.:TA1745A

REV. NO.:1.0

A. MAXIMUM RATING:

1. Input Power Level: 20 dBm
2. DC Voltage : 0V
3. Operating Temperature: -40°C to +85°C
4. Storage Temperature: -40°C to +85°C

RoHS Compliant
Lead free
Lead-free soldering

Electrostatic Sensitive Device (ESD)

B. ELECTRICAL CHARACTERISTICS:

Terminating source/load impedance (single) : $Z_s = 50 \Omega / Z_L = 50 \Omega$

Item	Unit	25±2°C	Type.	-40 ~ +85°C
Center Frequency Fc	MHz	-	1583	-
Insertion Loss (1559.1~1563.1 MHz) IL	dB	1.9max	1.8	2.1max
Insertion Loss (1571.42~1577.42 MHz) IL	dB	1.5max	1.4	1.6max
Insertion Loss (1597.55~1605.89 MHz) IL	dB	1.8max	1.7	2.1max
VSWR (1559.1~1563.1 MHz)		1.7max	1.8	2.0max
VSWR (1571.42~1577.42 MHz)		1.7max	1.8	2.0max
VSWR (1597.55~1605.89 MHz)		2.1max	2.0	2.2max
Amplitude ripple				
(1559.1~1563.1 MHz)	dB	0.6max	0.5	0.8max
(1571.42~1577.42 MHz)	dB	0.3max	0.2	0.5max
(1597.55~1605.89 MHz)	dB	0.5max	0.3	0.6max
Attenuation				
10 ~ 824 MHz	dB	45min	50	43min
824 ~ 925 MHz	dB	45min	50	43min
1427 ~ 1463 MHz	dB	28min	32	25min
1710 ~ 1785 MHz	dB	37min	40	34min
1850 ~ 1980 MHz	dB	37min	40	35min
2400 ~ 2570 MHz	dB	27min	30	25min
2570 ~ 3000 MHz	dB	25min	27	23min
Package size	mm	2016		

C. TEST CIRCUIT:

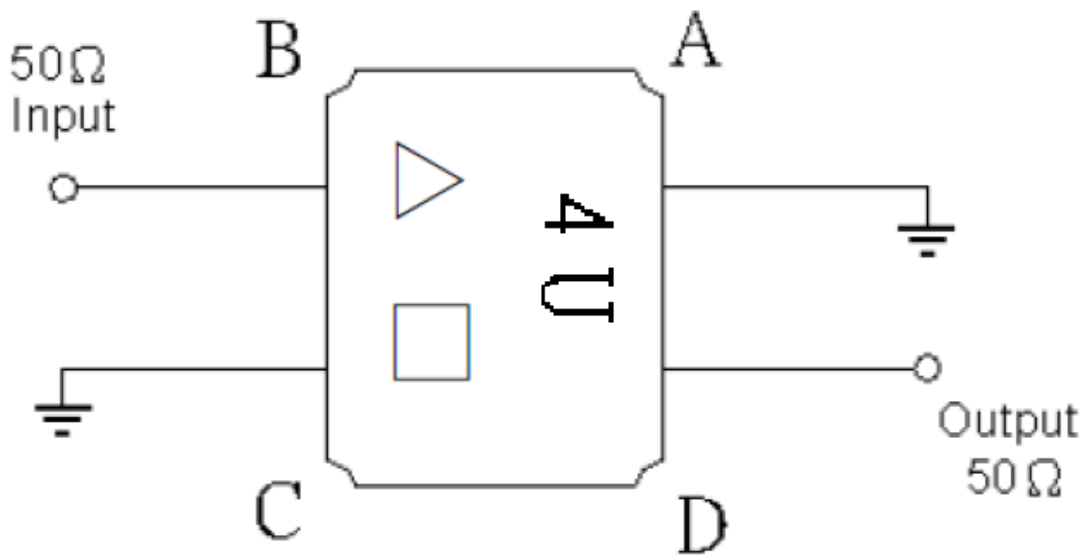

D. Frequency Characteristics :
S21 response: (span 500MHz)

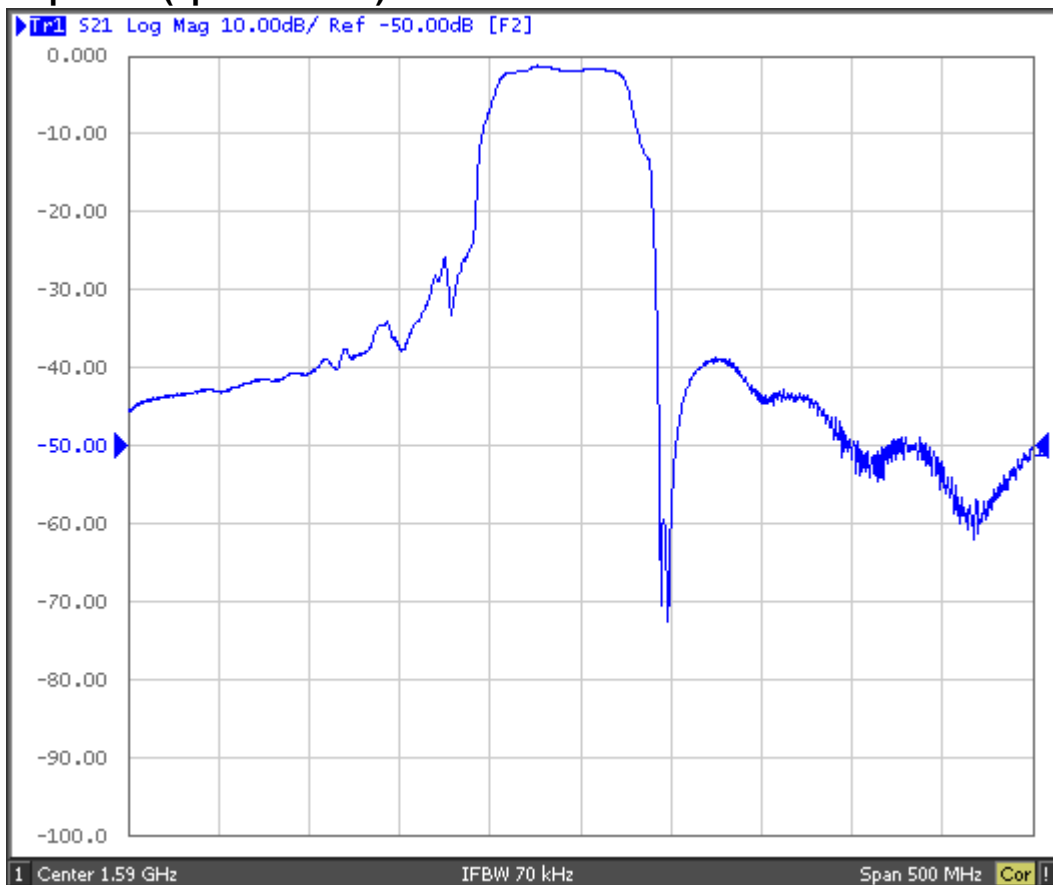

S21 response: (span 100MHz)

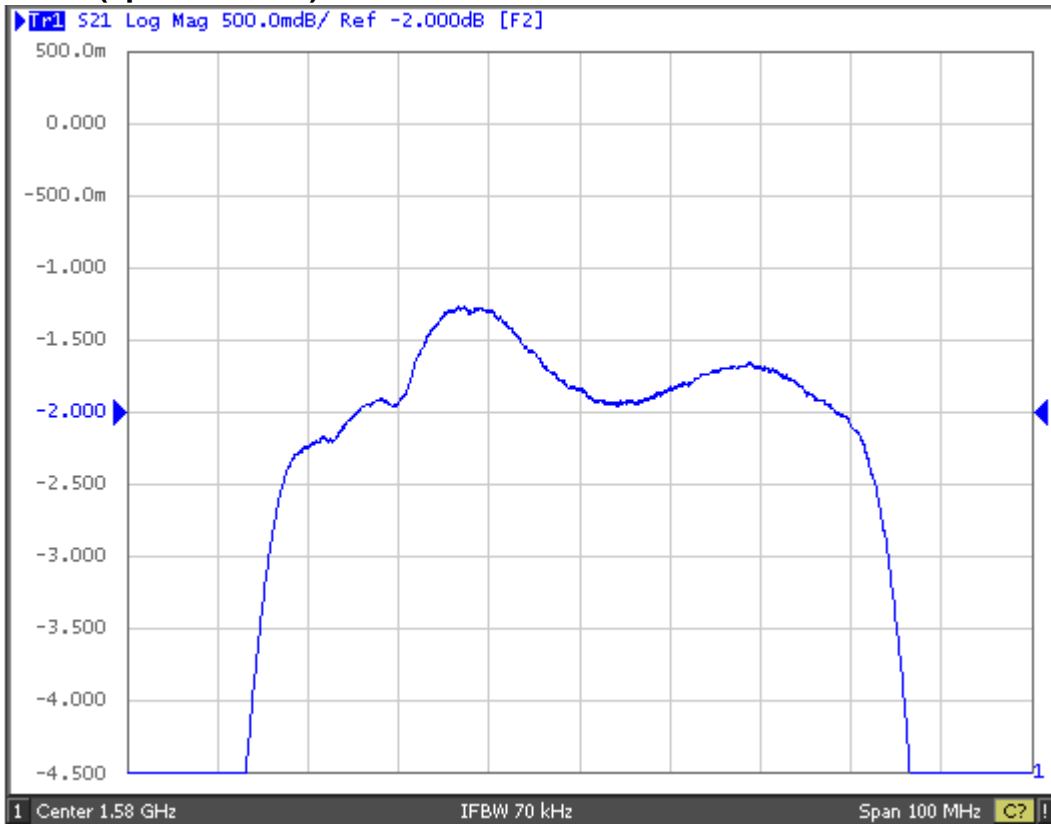

S11/S22 response :

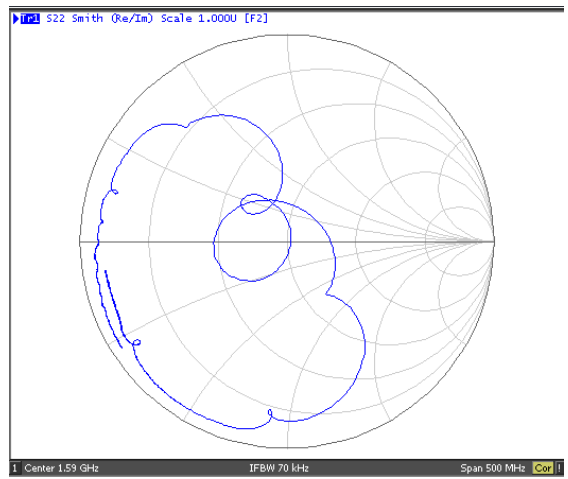
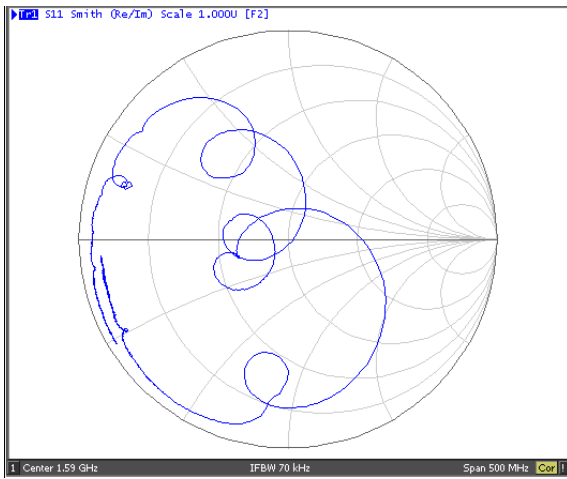

S21 response: (span 3GHz)

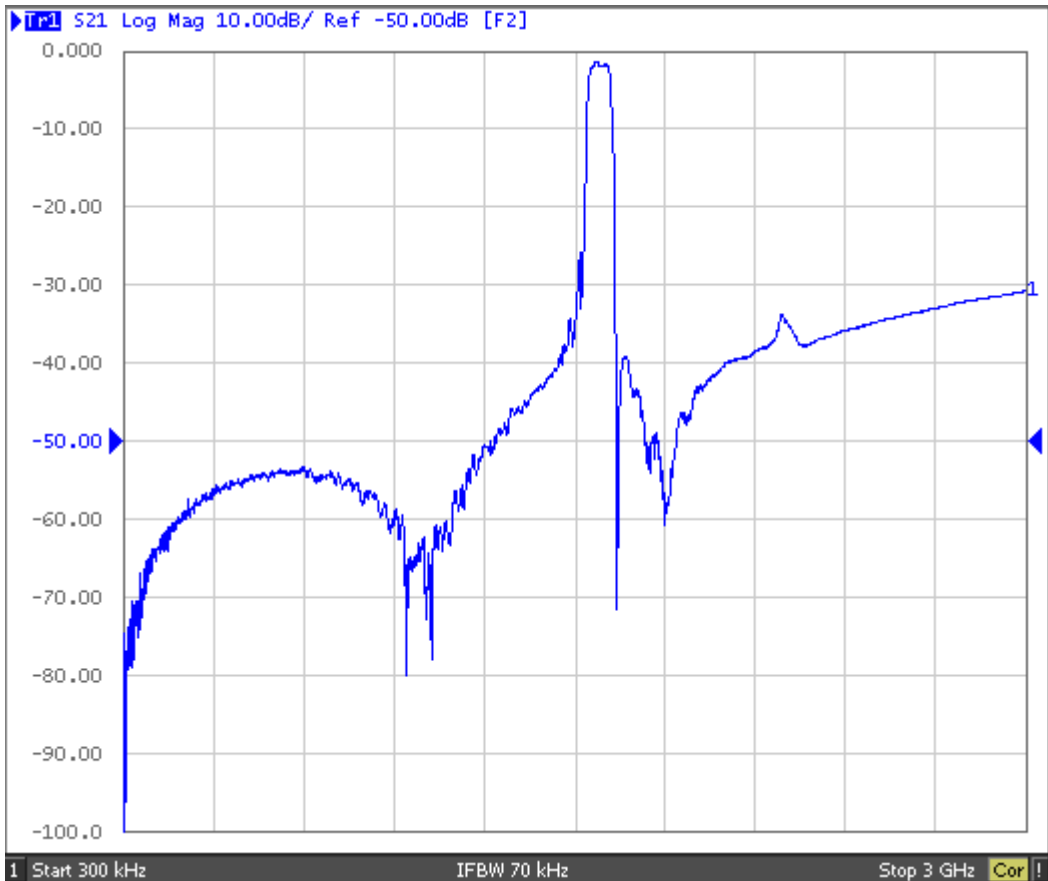

E.OUTLINE DRAWING:

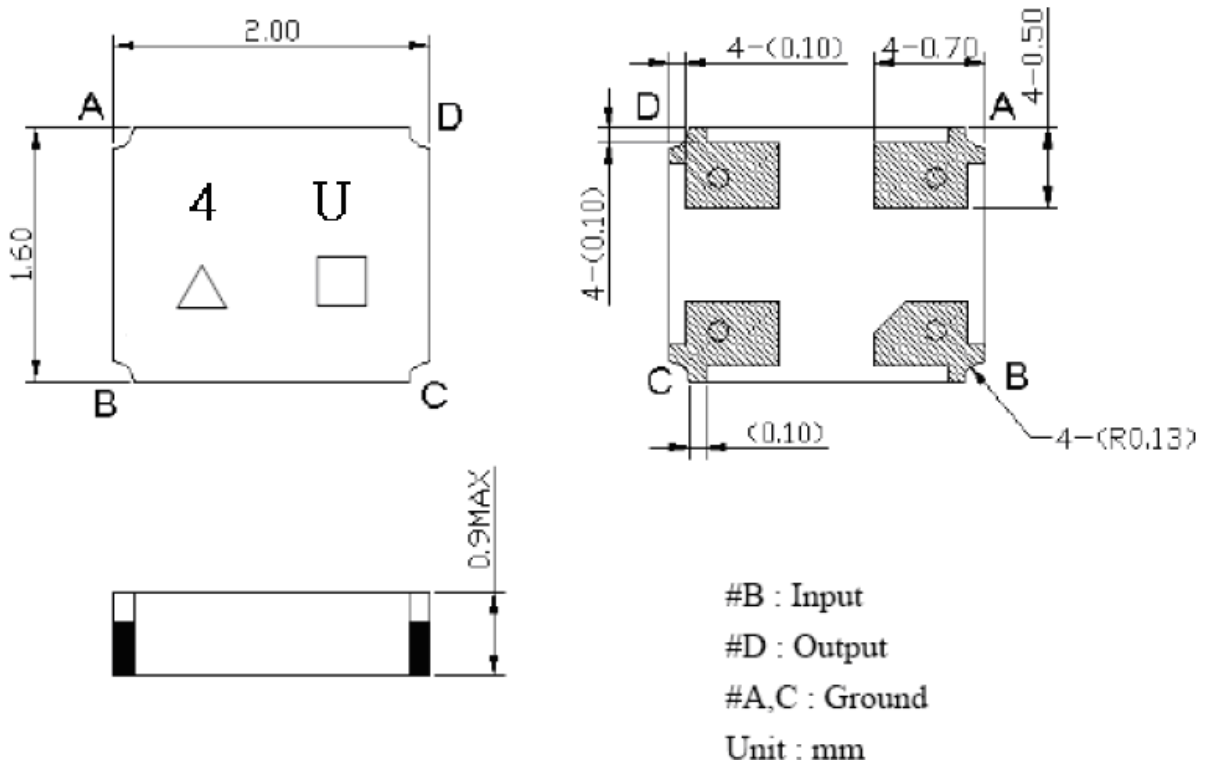

Date code : See the table

WK	01	02	...	26	27	28	...	52
Code	A	B	...	Z	a	b	...	z

△ Year code : See the table

Year	2008	2009	2010	2011	...	2019	2020
Code	8	9	0	1	...	9	0

F. PACKING:

1. REEL DIMENSION

(Please refer to FR-75D10 for packing quantity)

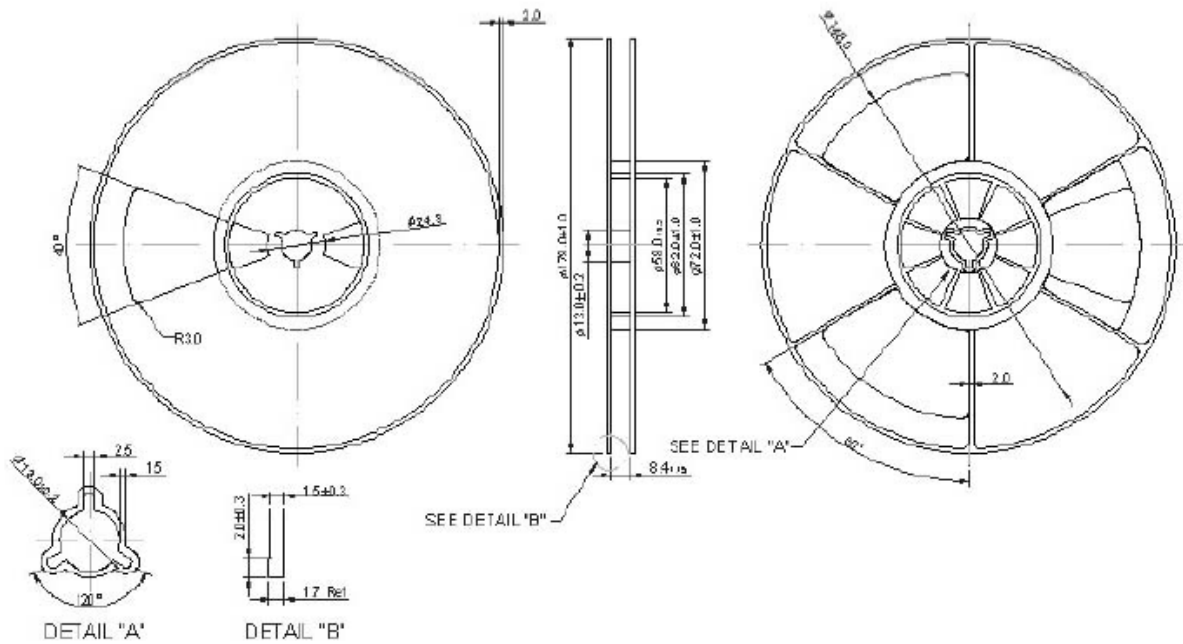

2. TAPE DIMENSION

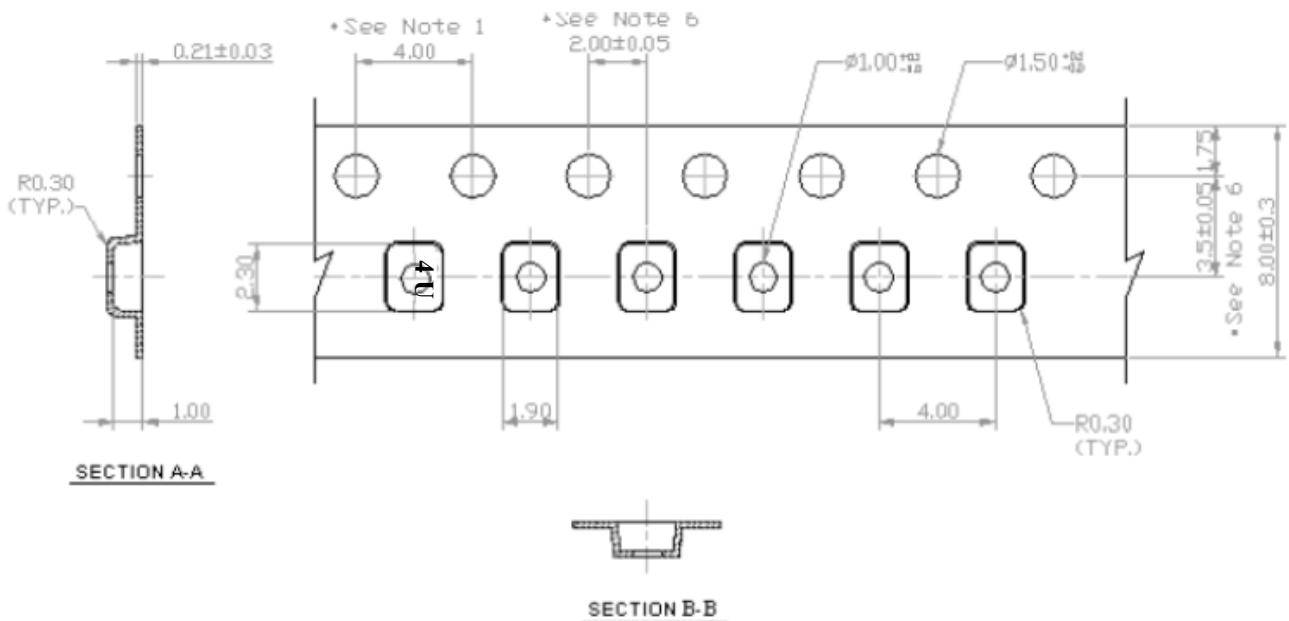

Direction of Feed
→

G. RECOMMENDED REFLOW PROFILE :

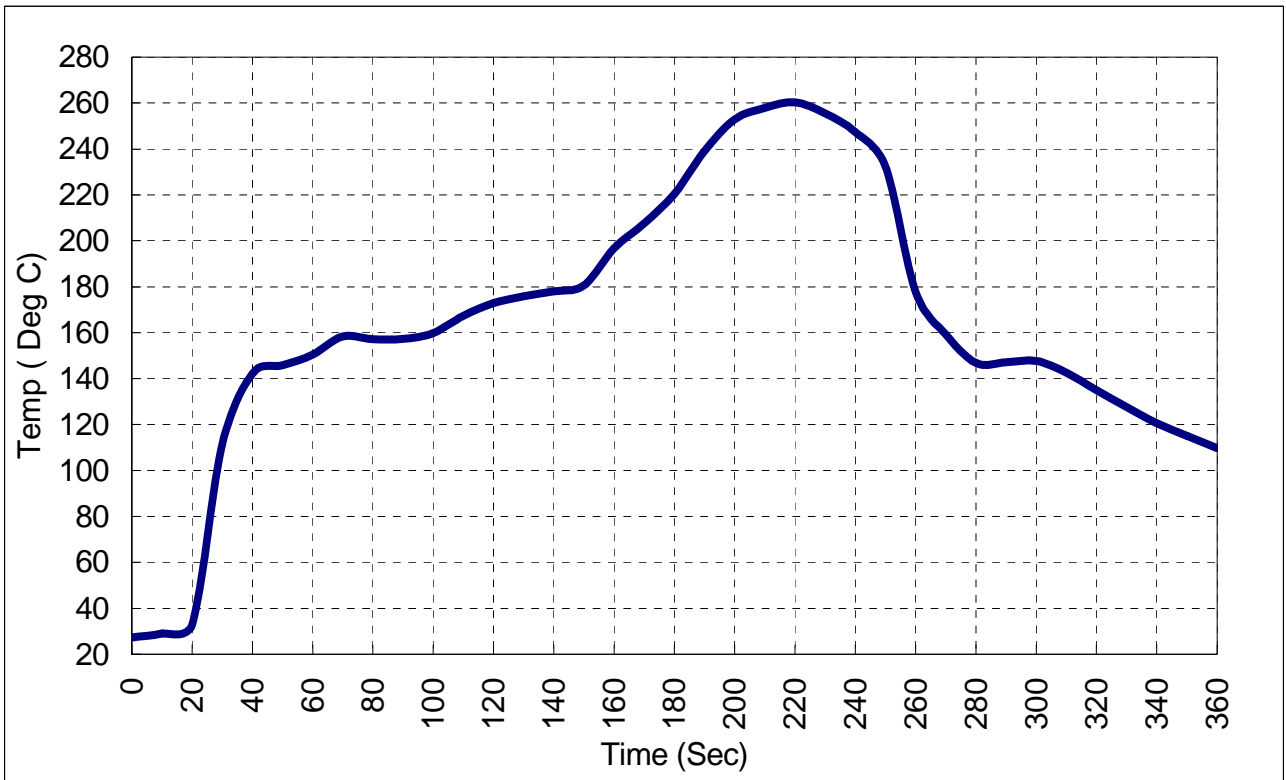

X-ON Electronics

Largest Supplier of Electrical and Electronic Components

Click to view similar products for [Signal Conditioning](#) category:

Click to view products by [Tai-Saw Technology](#) manufacturer:

Other Similar products are found below :

[MAPDCC0001](#) [MAPDCC0004](#) [PD0409J5050S2HF](#) [HHS-109-PIN](#) [AFS14A35-1591.50-T3](#) [DS-323-PIN](#) [DSS-313-PIN](#) [JP510S](#)
[LFB322G45SN1A504](#) [SF2159E](#) [FM-104-PIN](#) [CER0813B](#) [MAPDCC0005](#) [3A325](#) [BD0810N50100AHF](#) [JHS-115-PIN](#) [DC0710J5005AHF](#)
[DC2327J5005AHF](#) [LFB2H2G60BB1C106](#) [LFL15869MTC1B787](#) [X3C19F1-20S](#) [XC3500P-20S](#) [CDBLB455KCAX39-B0](#) [RF1353C](#) [051157-](#)
[0000](#) [PD0922J5050D2HF](#) [600S150FTRB](#) [1E1305-3](#) [1F1304-3S](#) [1G1304-30](#) [TP-103-PIN](#) [BD1222J50200AHF](#) [BD1722J50100AHF](#)
[2450DP39K5400E](#) [BD0810J50150AHF](#) [BD1722J50200AHF](#) [DSS-113-PIN](#) [DS-327-PIN](#) [MACP-008125-CK07F0](#) [DS-329-PIN](#) [DS-313-PIN](#)
[M38510/10304BCA](#) [TP-104-PIN](#) [HH-128-PIN](#) [JP506S](#) [XC0900P-10S](#) [XC0900B-30S](#) [CHE1260-QAG](#) [11305-10](#) [5962-9091202MXA](#)