



TAI-SAW TECHNOLOGY CO., LTD.

No. 3, Industrial 2nd Rd., Ping-Chen Industrial District,
Taoyuan, 324, Taiwan, R.O.C.

TEL: 886-3-4690038 FAX: 886-3-4697532

E-mail: tstsales@mail.taisaw.com Web: www.taisaw.com

Product Specifications Approval Sheet

Product Description: SAW Rx Filter 1842.5MHz LTE Band 3 SMD 1109

TST Part No.: TA1857A

Customer Part No.: _____

Customer signature required
Company: _____
Division: _____
Approved by : _____
Date: _____

Checked by: _____ Hayley Chou *Hayley Chou*

Approved by: _____ Andy Yu *Andy Yu*

Date: _____ 2017, 04. 05

1. Customer signed back is required before TST can proceed with sample build and receive orders.
2. Orders received without customer signed back will be regarded as agreement on the specifications.
3. Any specifications changes must be approved upon by both parties and a new revision of specifications shall be released to reflect the changes.



TAI-SAW TECHNOLOGY CO., LTD.

No. 3, Industrial 2nd Rd., Ping-Chen Industrial District,
Taoyuan, 324, Taiwan, R.O.C.

TEL: 886-3-4690038 FAX: 886-3-4697532

E-mail: tstsales@mail.taisaw.com Web: www.taisaw.com

SAW Rx Filter 1842.5MHz LTE Band 3 SMD 1109 (75MHz BW)

MODEL NO.: TA1857A

REV. NO.:2

A. MAXIMUM RATING:

1. Operating temperature range: -30 °C to +85 °C
2. Storage temperature range: -40 °C to +100 °C
3. Maximum Input Power: +10 dBm
4. Maximum DC Voltage: +/-5 V
5. Moisture Sensitivity Level: Level 1
6. ESD 50V(MM) 100V(HBM)

RoHS Compliant
Lead free
Lead-free soldering

Electrostatic Sensitive Device (ESD)

B. ELECTRICAL CHARACTERISTICS:

Terminating source impedance: $Z_s = 50 \Omega$ (Unbalanced)

Terminating load impedance: $Z_L = 100//18nH \Omega$ (Balanced / differential)

Parameters Description		Unit	Min.	Typ.	Max.
Center Frequency		MHz	-	1842.5	-
Insertion Loss(*1)	1805~1880 MHz	dB	-	3.2	4.5
Amplitude Ripple	1805~1880 MHz	dB	-	1.9	3.3
VSWR(Input)	1805~1880 MHz	-	-	1.8	2.3
VSWR(Output)	1805~1880 MHz	-	-	2.0	2.3
Amplitude Balance ($ S_{21} / S_{31} $)	1805~1880 MHz	dB	-1.3	+0.8/-0.5	+1.3
Phase Balance ($(\Phi_{S21}-\Phi_{S31})+180$)	1805~1880 MHz	deg.	+12	+3/-3	-12
Attenuation:					
10~1300 MHz		dB	40	63	-
1300~1705 MHz		dB	40	53	-
1705~1785 MHz		dB	41	45	-
1920~1980 MHz		dB	24	28	-
1980~3000 MHz		dB	30	38	-
3000~5000 MHz		dB	30	50	-
5000~6000 MHz		dB	30	48	-

(*1) Specification of insertion loss includes loss that comes from the test board. (Value: 0.15dB)

C. FREQUENCY CHARACTERISTICS:

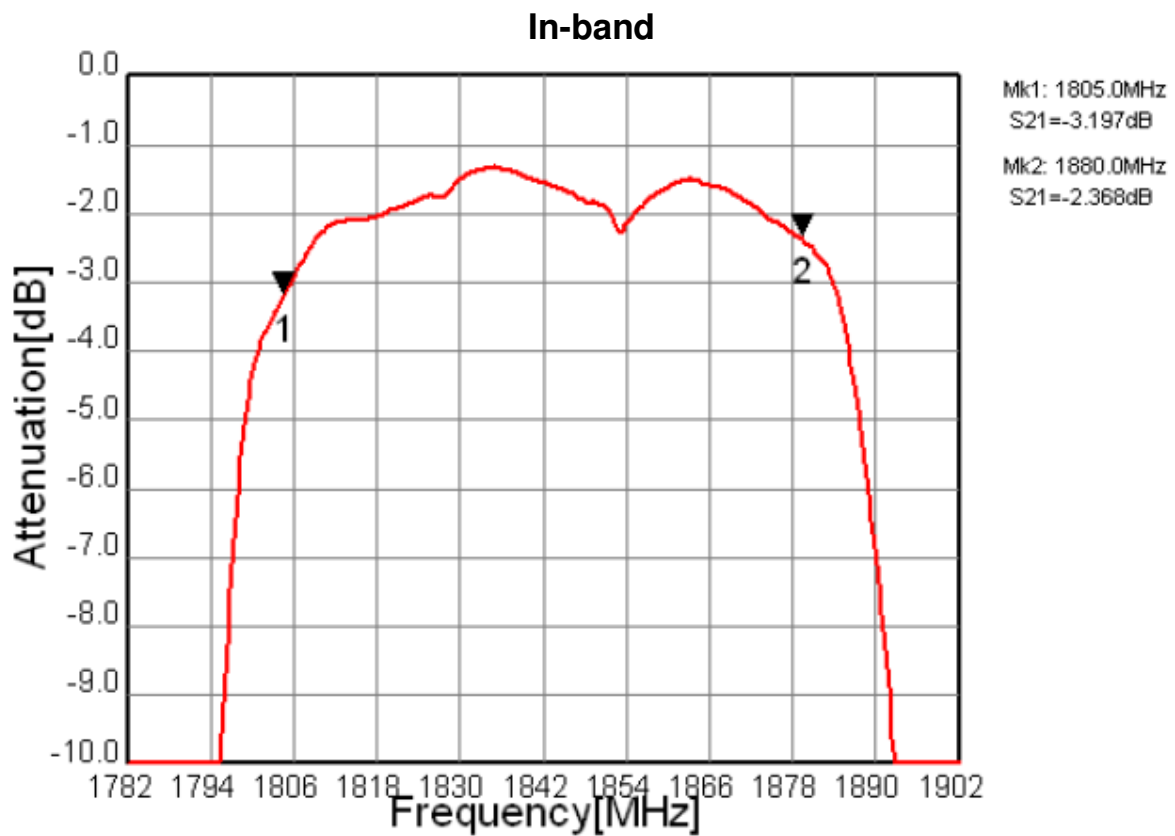
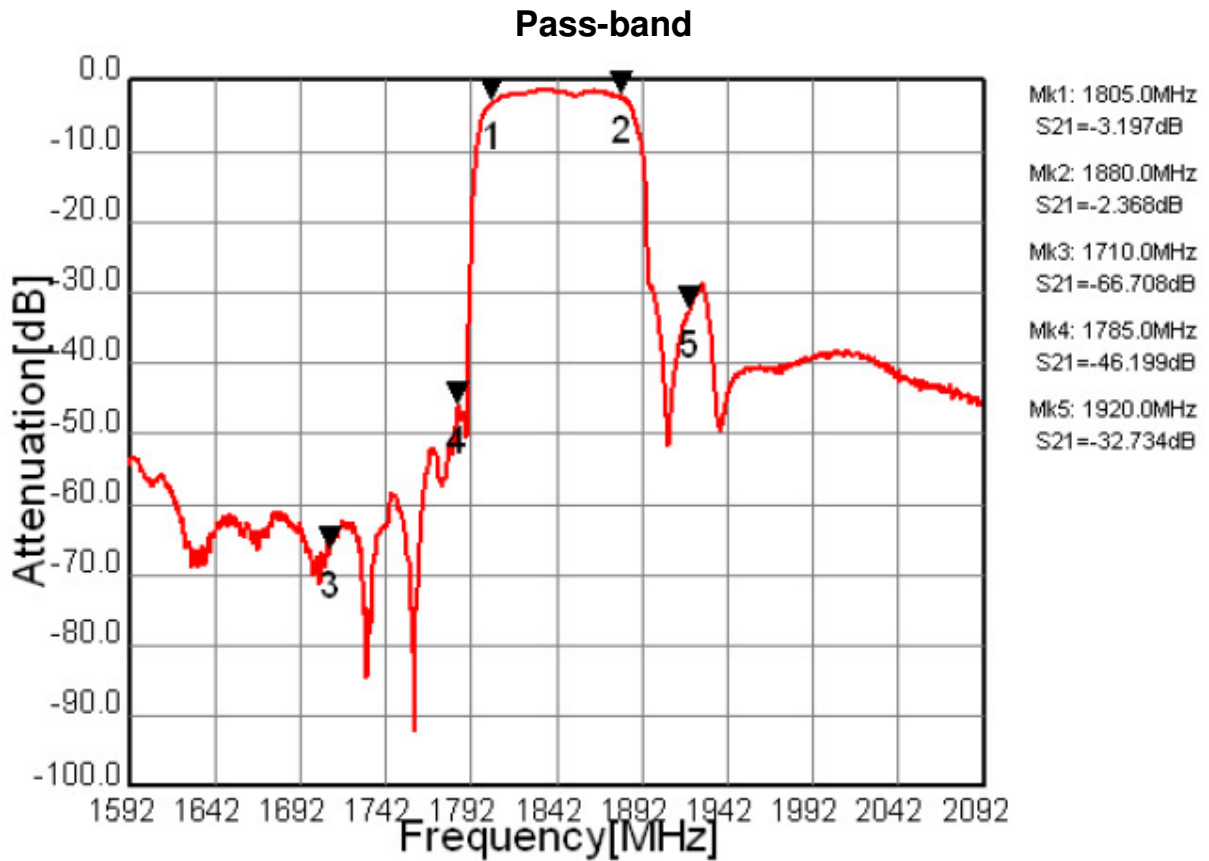

Wide-band

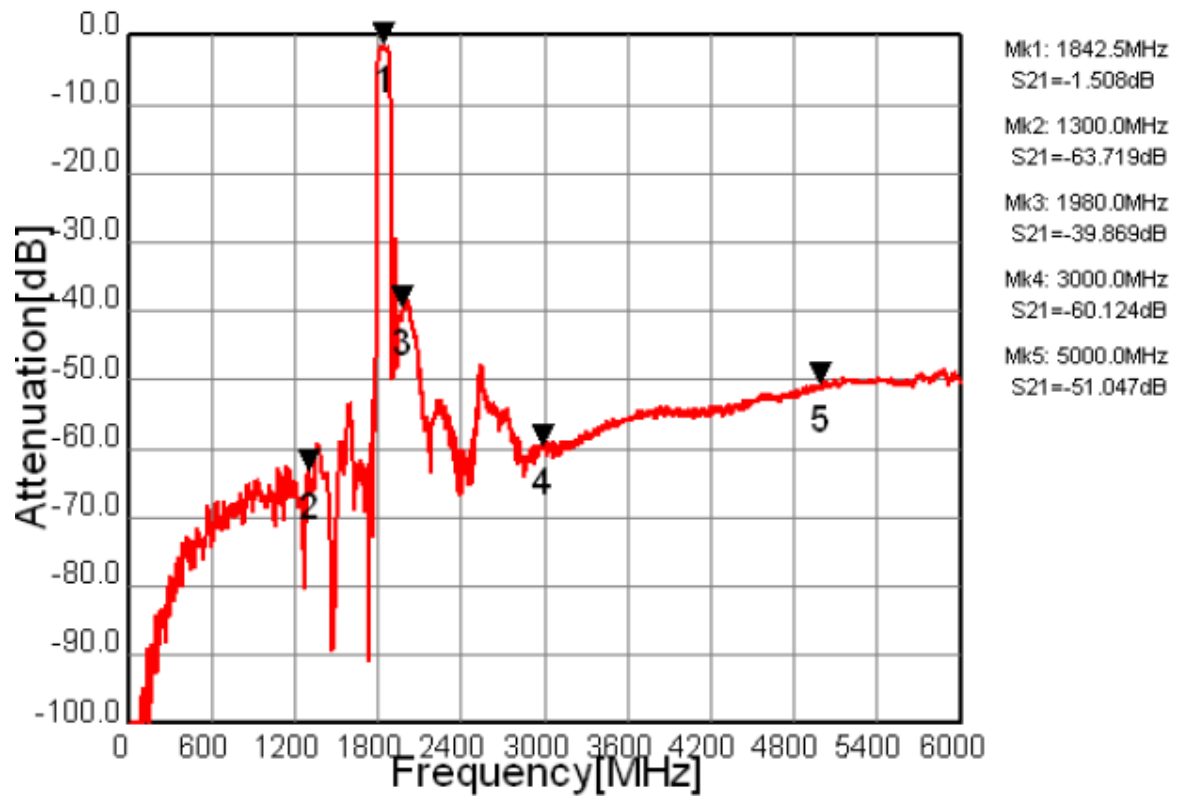

VSWR (Input)

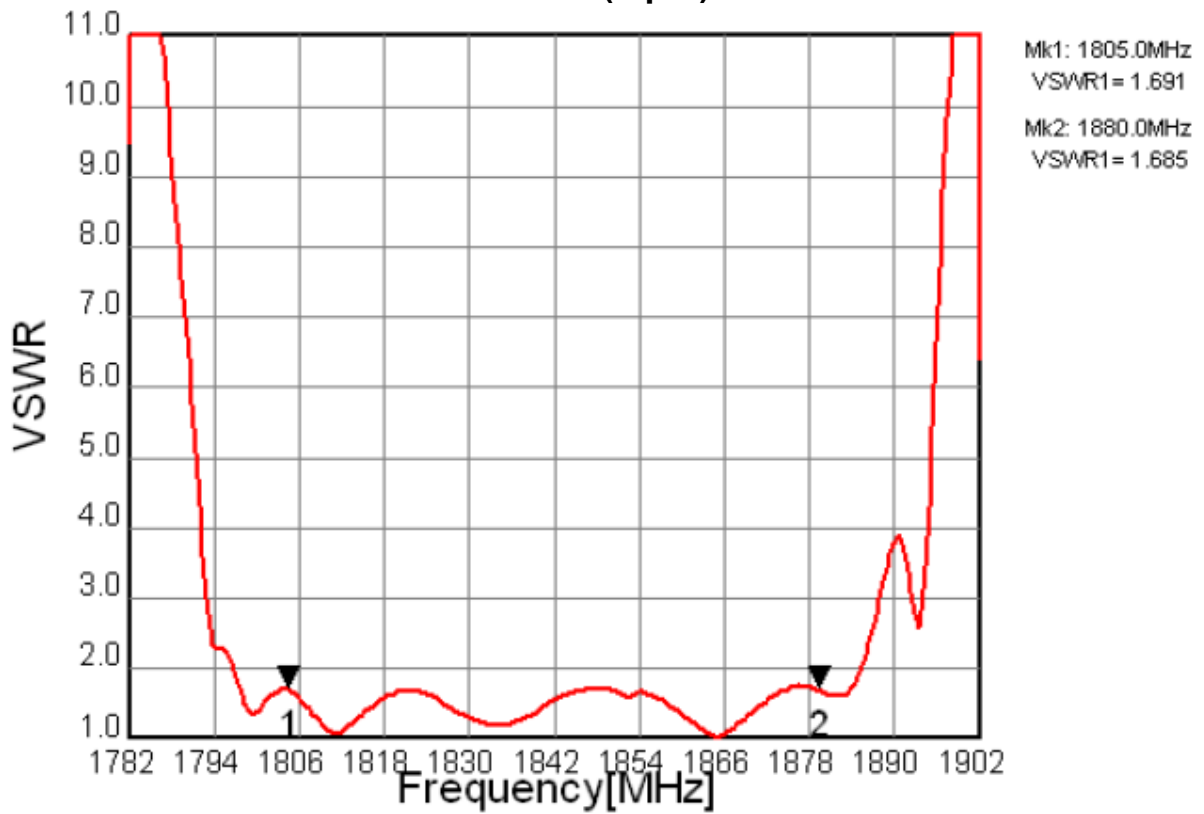

VSWR (Output)

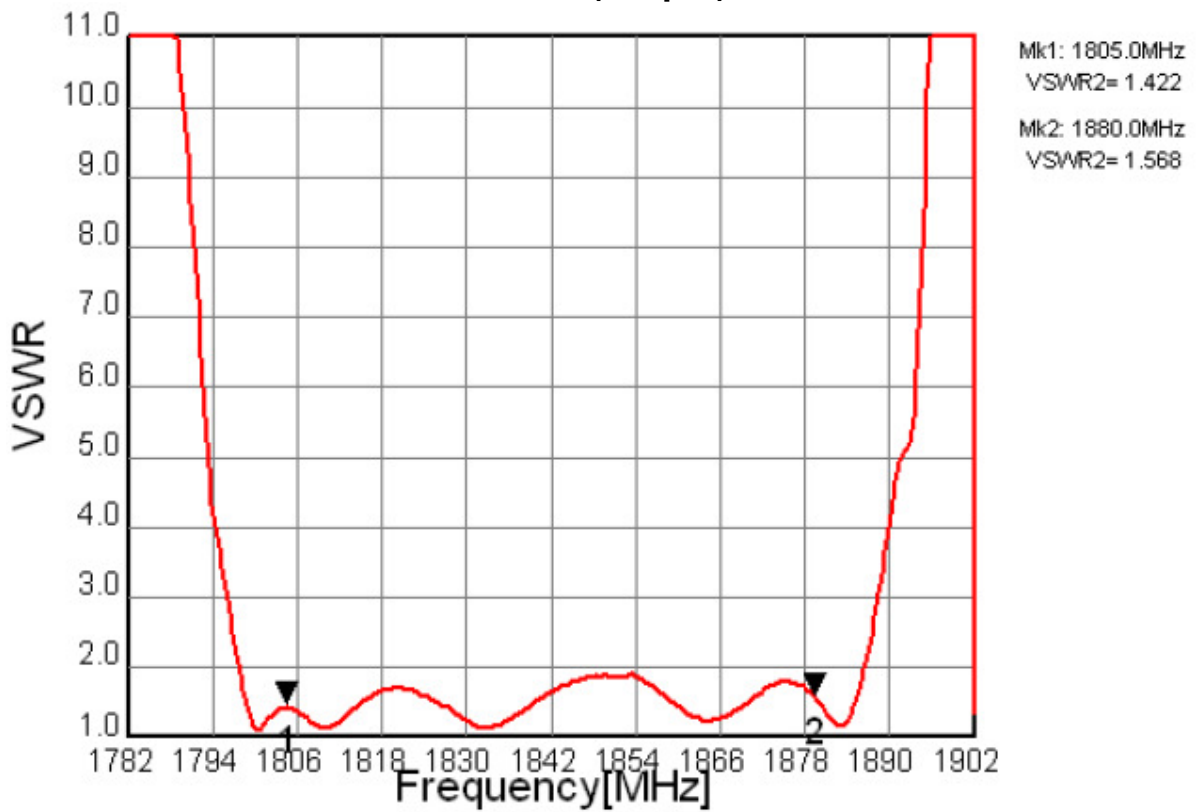

Input Impedance

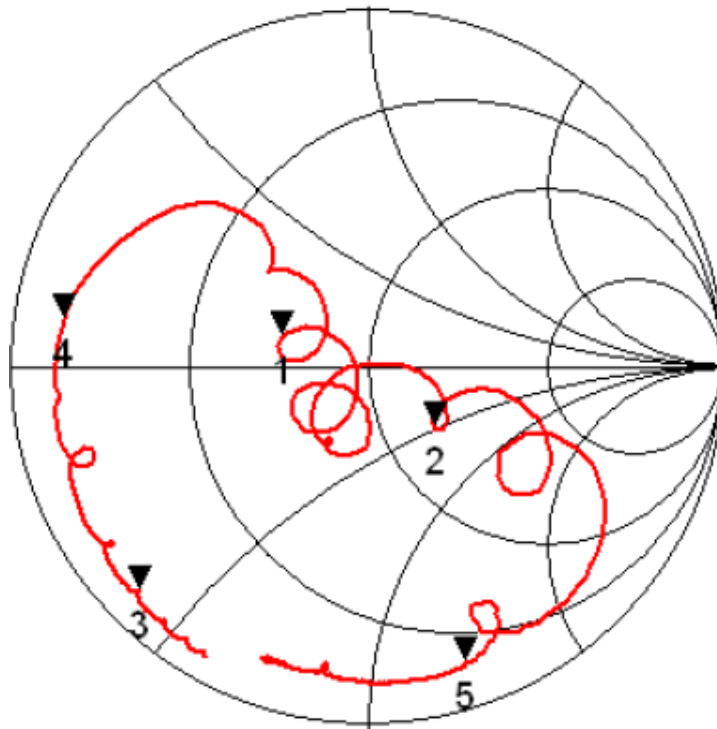

Mk1: 1805.0
S11= 0.601 + j 0.113
Mk2: 1880.0
S11= 1.363 - j 0.500
Mk3: 1710.0
S11= 0.061 - j 0.406
Mk4: 1785.0
S11= 0.073 + j 0.079
Mk5: 1920.0
S11= 0.194 - j 1.368

Output Impedance

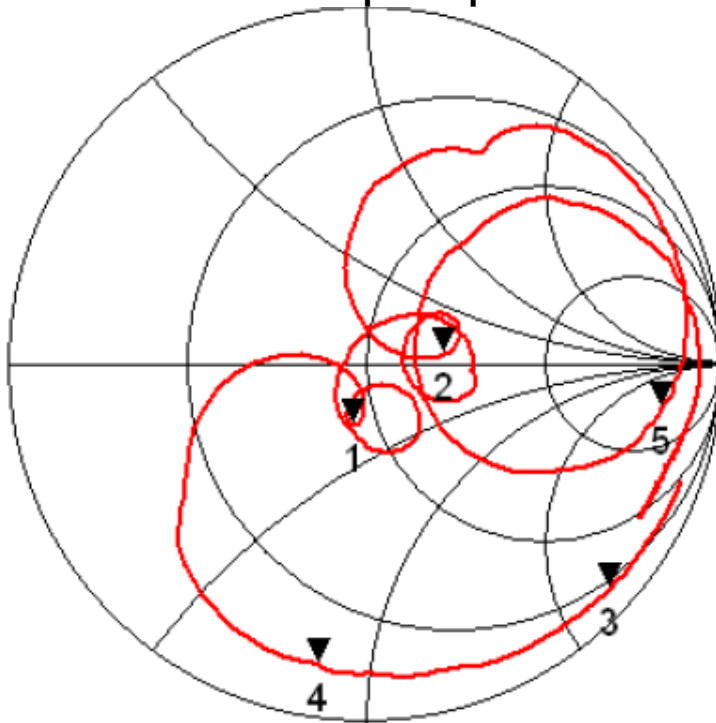

Mk1: 1805.0
S22= 0.873 - j 0.306
Mk2: 1880.0
S22= 1.568 + j 0.106
Mk3: 1710.0
S22= 0.270 - j 2.528
Mk4: 1785.0
S22= 0.135 - j 0.842
Mk5: 1920.0
S22= 6.664 - j 5.564

Amplitude Balance

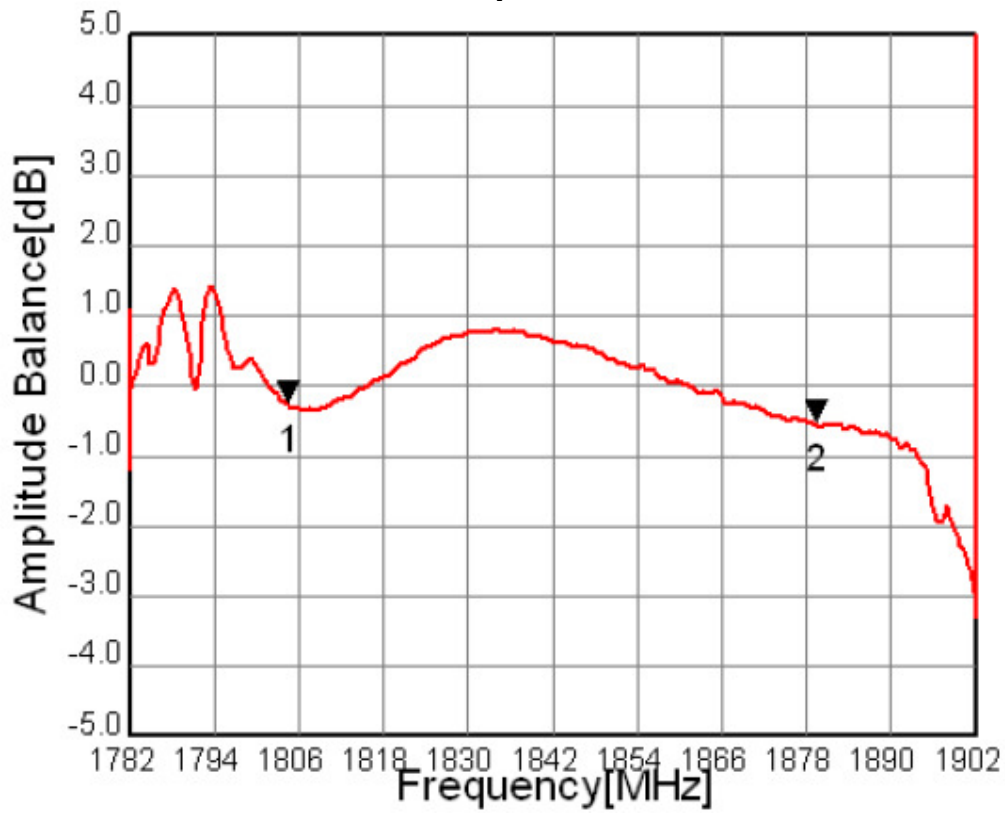

Phase Balance

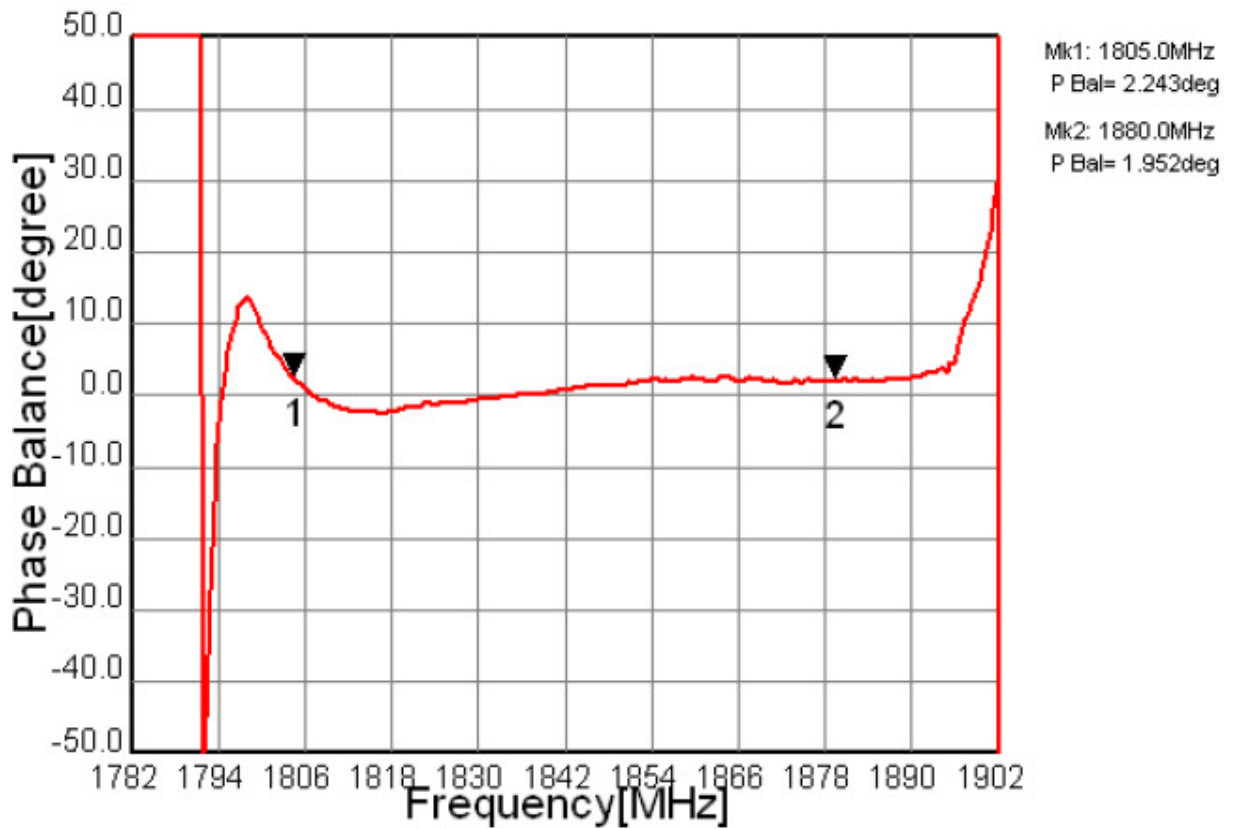

D. MEASUREMENT CIRCUIT:

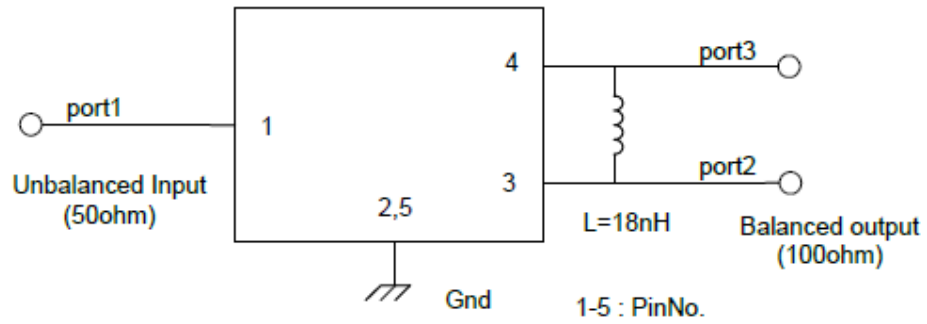

E. OUTLINE DRAWING:

Device size: 1.1typ. x 0.9typ. x 0.5max.

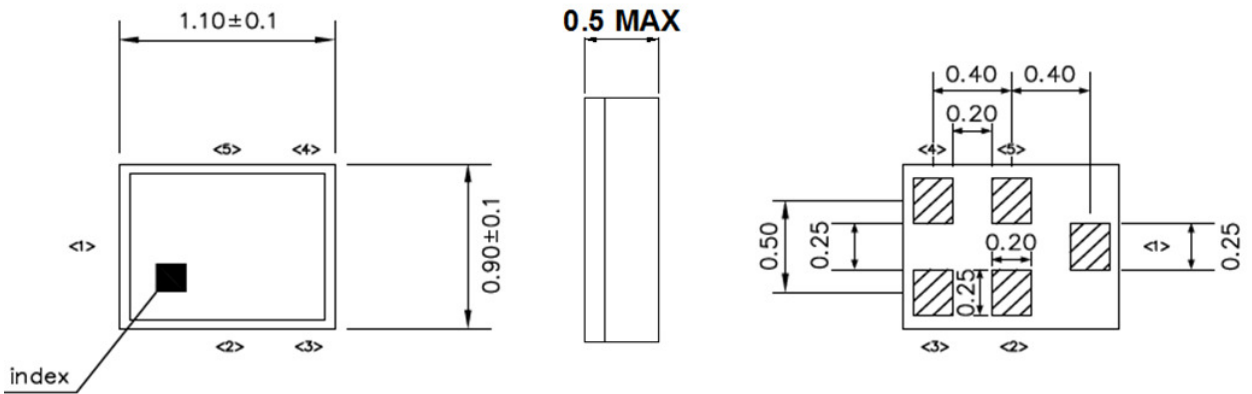

Unit : mm

Pin Configuration

Pin No.	Symbol	Function
1	IN	Unbalanced pin
2	GND	Ground
3	OUT	Balanced pin
4	OUT	Balanced pin
5	GND	Ground

Top View (Sample Run):

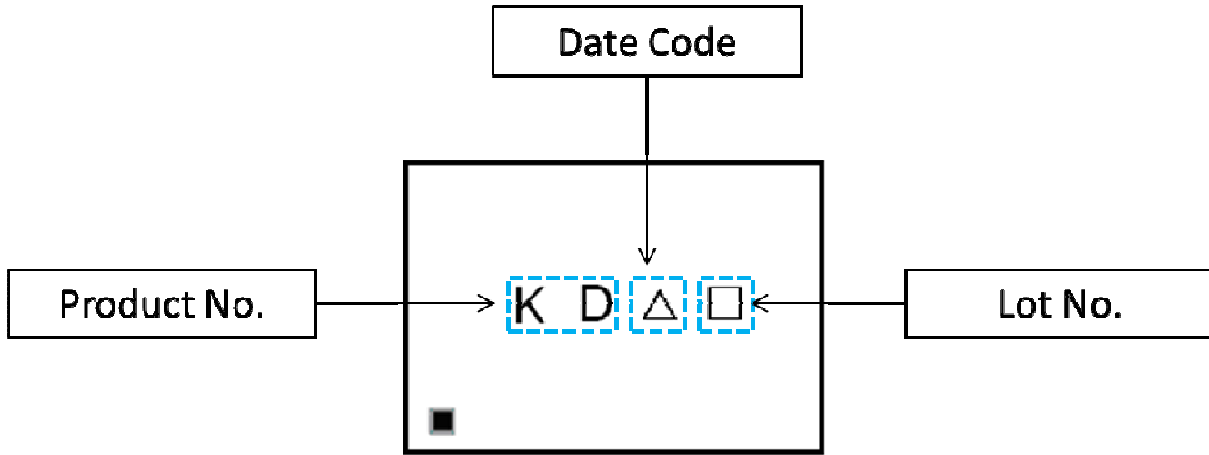

Top View (Pilot Run):

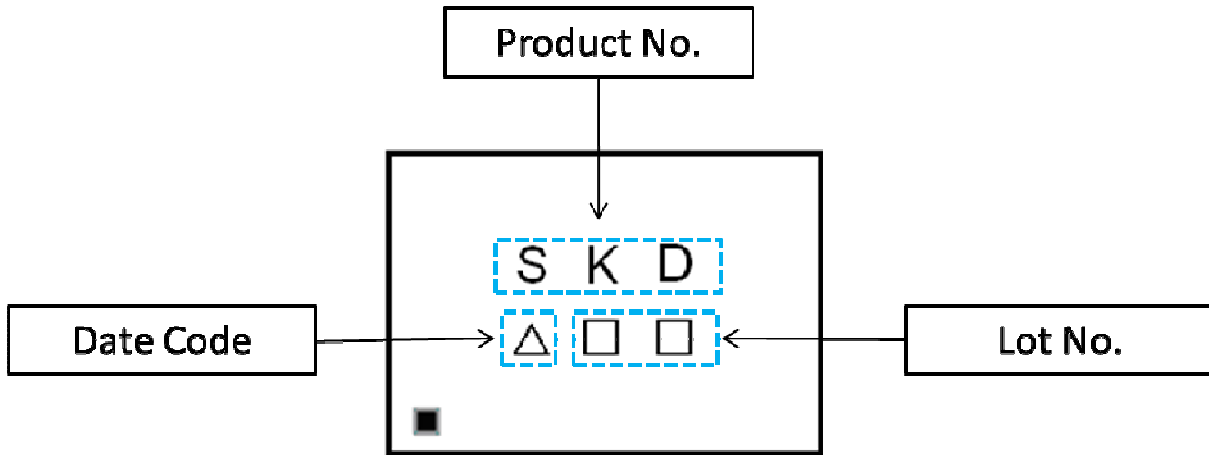

△ : Date Code

□ : Lot No. (Indicated by 0~9 or A to Z and a to z, except I, O, i, o and l)

Product date Code (EIAJ)

Year	Jan	Feb	Mar	Apr	May	Jun	Jul	Aug	Sep	Oct	Nov	Dec
2015	a	b	c	d	e	f	g	h	j	k	l	m
2016	n	p	q	r	s	t	u	v	w	x	y	z
2017	A	B	C	D	E	F	G	H	J	K	L	M
2018	N	P	Q	R	S	T	U	V	W	X	Y	Z

F. PACKING:

1. REEL DIMENSION

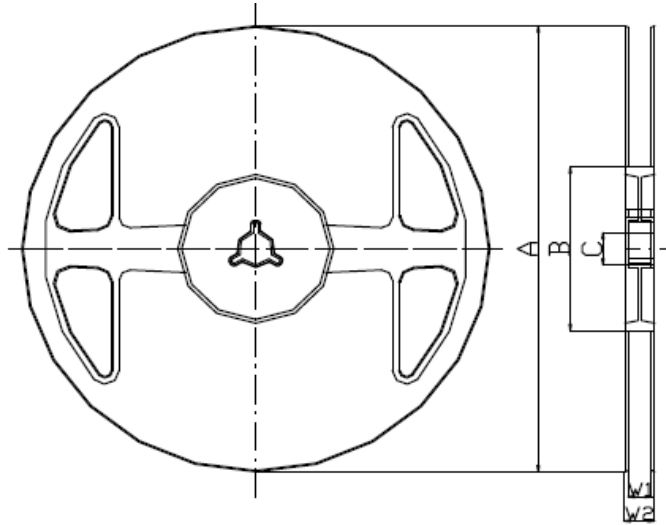

Materials of Reel

Material : Polystyrene + Carbon

Color : Black

Surface resistance (reference value) : $10^9 \Omega/\text{sq}$ Max.

Unit : mm

Code	Quantity	A	B	C	W1	W2
J	5,000 pcs	$\phi 180.0 +0.0/-1.5$	$\phi 66.0 +/-0.5$	$\phi 13.0 +/-0.2$	$9.0 +1.0/-0.0$	$11.4 +/-1.0$

2. TAPE DIMENSION

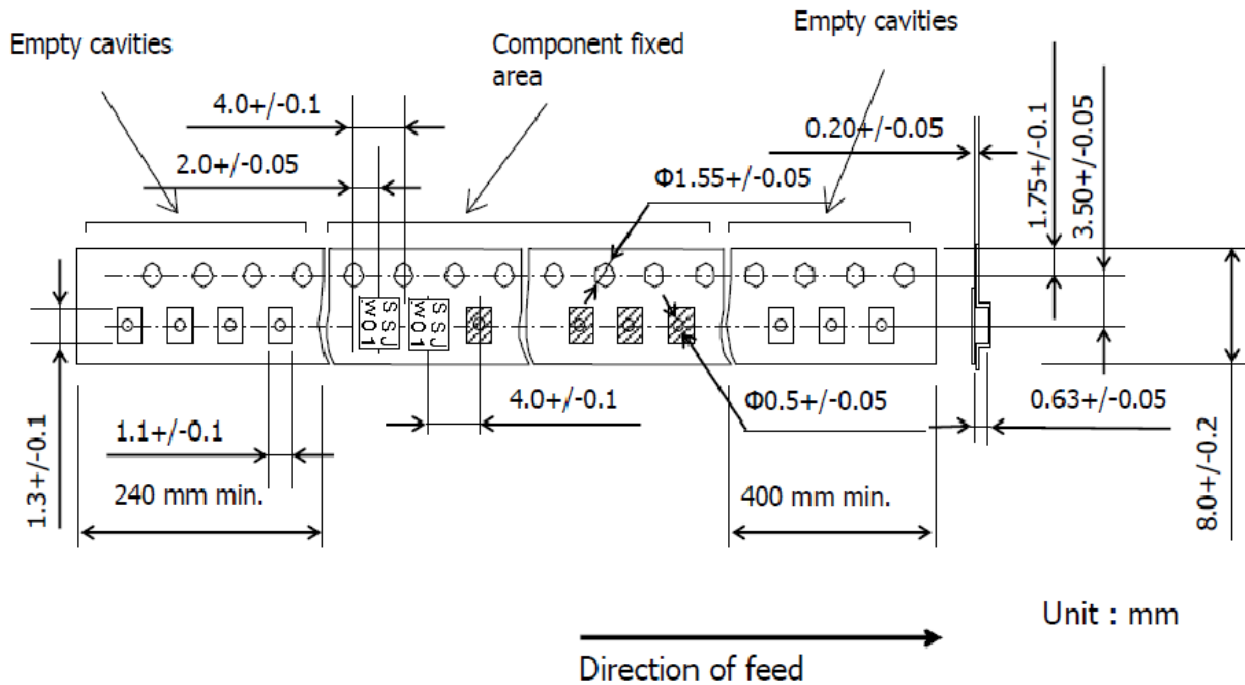

Unit : mm

G. RECOMMENDED REFLOW PROFILE:

1. Preheating shall be fixed at 150~180°C for 60~90 seconds.
2. Ascending time to preheating temperature 150°C shall be 30 seconds min.
3. Heating shall be fixed at 220°C for 50~80 seconds and at 260°C +0/-5°C peak (20~40sec).
4. Time: 2 times.

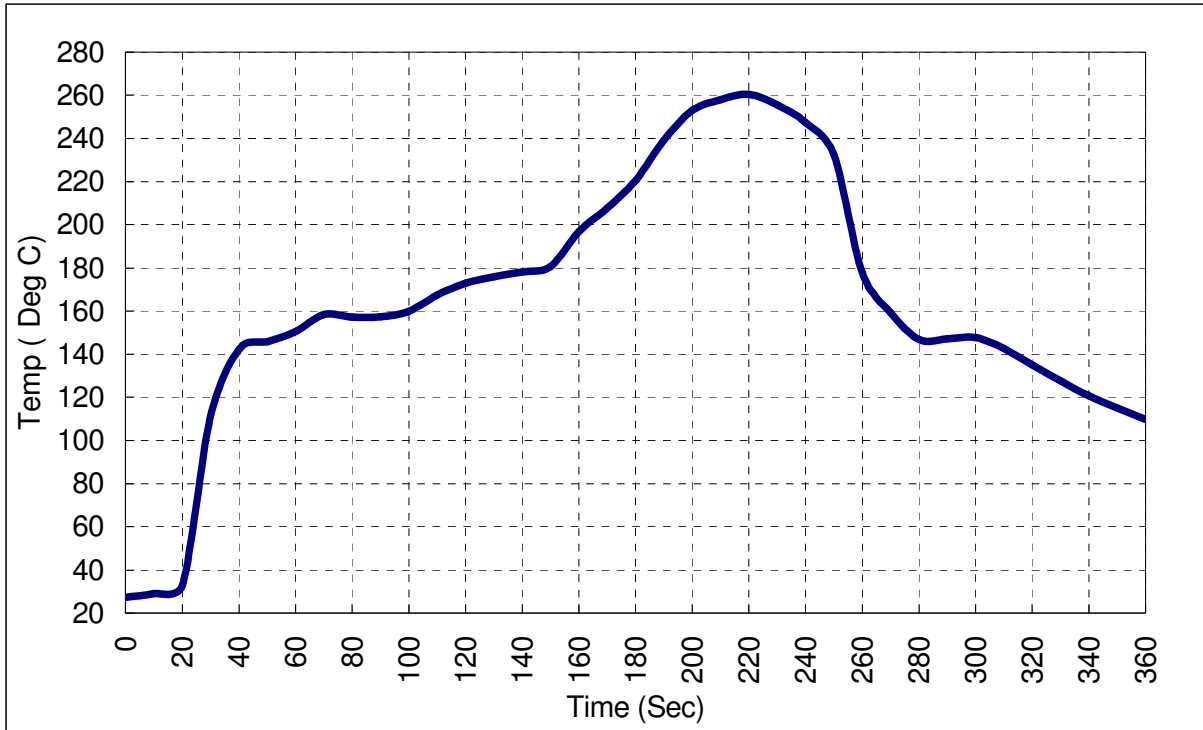

X-ON Electronics

Largest Supplier of Electrical and Electronic Components

Click to view similar products for [Signal Conditioning category](#):

Click to view products by [Tai-Saw Technology manufacturer](#):

Other Similar products are found below :

[MAPDCC0004](#) [PD0409J5050S2HF](#) [HHS-109-PIN](#) [AFS14A35-1591.50-T3](#) [DS-323-PIN](#) [DSS-313-PIN](#) [1A0220-3](#) [JP510S](#)

[LFB212G45SG8C341](#) [LFB322G45SN1A504](#) [LFL182G45TC3B746](#) [SF2159E](#) [30057](#) [AFS1575.42S4-T](#) [FM-104-PIN](#) [CER0813B](#)

[MAPDCC0005](#) [3A325](#) [40287](#) [BD0810N50100AHF](#) [JHS-115-PIN](#) [DC0710J5005AHF](#) [DC2327J5005AHF](#) [43020](#) [LFB2H2G60BB1C106](#)

[LFL15869MTC1B787](#) [X3C19F1-20S](#) [XC3500P-20S](#) [10013-20](#) [SF2194E](#) [CDBLB455KCAX39-B0](#) [RF1353C](#) [051157-0000](#)

[PD0922J5050D2HF](#) [1E1305-3](#) [1F1304-3S](#) [1G1304-30](#) [B0922J7575AHF](#) [10017-3](#) [TP-103-PIN](#) [BD1222J50200AHF](#) [BD1722J50100AHF](#)

[2450DP39K5400E](#) [BD0810J50150AHF](#) [BD1722J50200AHF](#) [DSS-113-PIN](#) [DS-327-PIN](#) [MACP-008125-CK07F0](#) [DS-329-PIN](#) [DS-313-PIN](#)