



TAI-SAW TECHNOLOGY CO., LTD.

No. 3, Industrial 2nd Rd., Ping-Chen Industrial District,
Taoyuan, 324, Taiwan, R.O.C.

TEL: 886-3-4690038 FAX: 886-3-4697532

E-mail: tstsales@mail.taisaw.com Web: www.taisaw.com

Product Specifications Approval Sheet

Product Name: SAW Rx Filter 1960MHz LTE Band 2 SMD 1109

TST Parts No.: TA1870C

Customer Parts No.: _____

Customer signature required
Company: _____
Division: _____
Approved by : _____
Date: _____

Checked by: _____ Hayley Chou *Hayley Chou*

Approval by: _____ Andy Yu *Andy Yu*

Date: _____ 2017, 04. 05

1. Customer signed back is required before TST can proceed with sample build and receive orders.
2. Orders received without customer signed back will be regarded as agreement on the specifications.
3. Any specifications changes must be approved upon by both parties and a new revision of specifications shall be released to reflect the changes.



TAI-SAW TECHNOLOGY CO., LTD.

No. 3, Industrial 2nd Rd., Ping-Chen Industrial District,
Taoyuan, 324, Taiwan, R.O.C.

TEL: 886-3-4690038 FAX: 886-3-4697532

E-mail: tstsales@mail.taisaw.com Web: www.taisaw.com

SAW Rx Filter 1960MHz LTE Band 2 SMD 1109 (60MHz BW)

MODEL NO.:TA1870C

REV.2

A. MAXIMUM RATING:

1. Operating temperature range: -30 °C to +90 °C
2. Storage temperature range: -40 °C to +100 °C
3. Maximum Input Power: +10 dBm
4. Maximum DC Voltage: +/-5 V
5. Moisture Sensitivity Level: Level 1
6. ESD 50V(MM) 100V(HBM)

RoHS Compliant
Lead free
Lead-free soldering

Electrostatic Sensitive Device (ESD)

B. ELECTRICAL CHARACTERISTICS:

Terminating source impedance: $Z_s = 50 \Omega$ (Single-ended)

Terminating load impedance: $Z_L = 50//4.7nH \Omega$ (Single-ended)

Parameters Description		Unit	Min.	Typ.	Max.
Center Frequency		MHz	-	1960	-
Insertion Loss(*1)	1930~1990 MHz	dB	-	2.8	4.0
Amplitude ripple	1930~1990 MHz	dB	-	1.3	2.7
VSWR(Input)	1930~1990 MHz	-	-	1.9	2.2
VSWR(Output)	1930~1990 MHz	-	-	2.0	2.3
Attenuation:					
DC~960 MHz		dB	40	45	-
1558~1608 MHz		dB	35	40	-
1710~1850 MHz		dB	35	40	-
1850~1910 MHz		dB	35	39	-
2020~2070 MHz		dB	7	27	-
2070~2400 MHz		dB	25	33	-
2400~2500 MHz		dB	33	43	-
2500~3780 MHz		dB	28	40	-
3780~3980 MHz		dB	30	39	-
3980~5790 MHz		dB	21	31	-
5790~5970 MHz		dB	21	31	-
5970~7720 MHz		dB	21	31	-
7720~7960 MHz		dB	17	27	-
7960~8000 MHz		dB	17	27	-

(*1) Specification of insertion loss excludes loss that comes from the test board.

C. FREQUENCY CHARATERISTIC:

Frequency Response

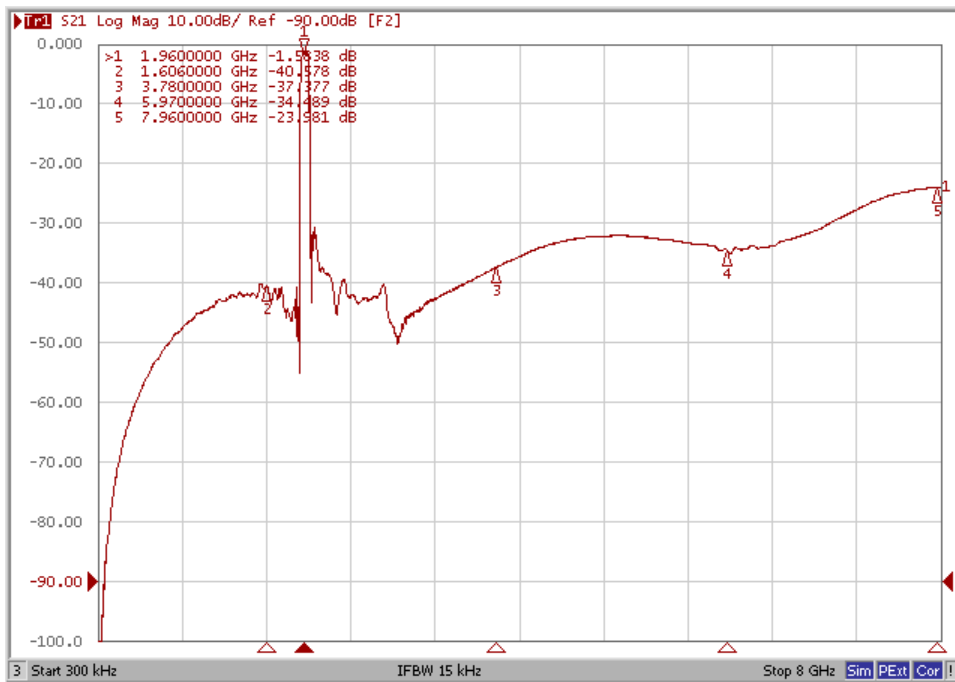
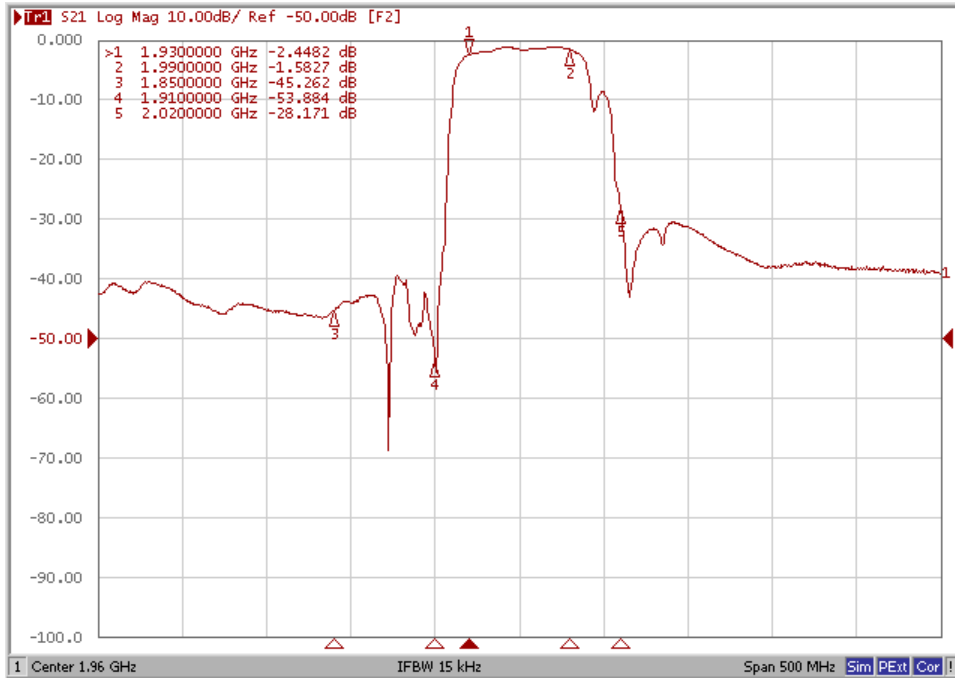

Ripple

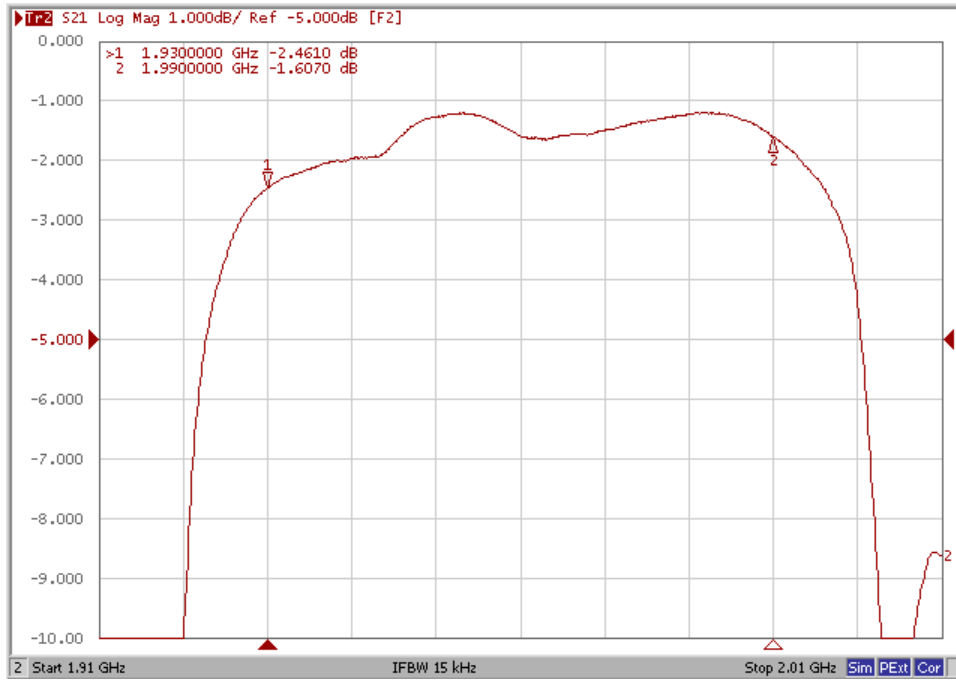

Smith Chart (S11)

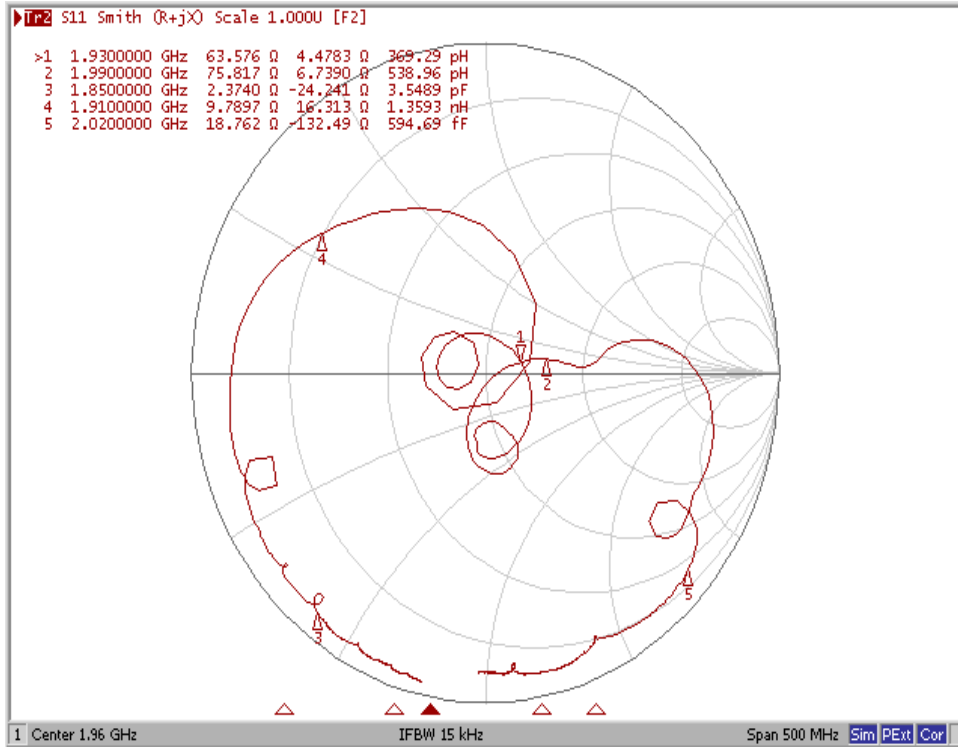

Smith Chart (S22)

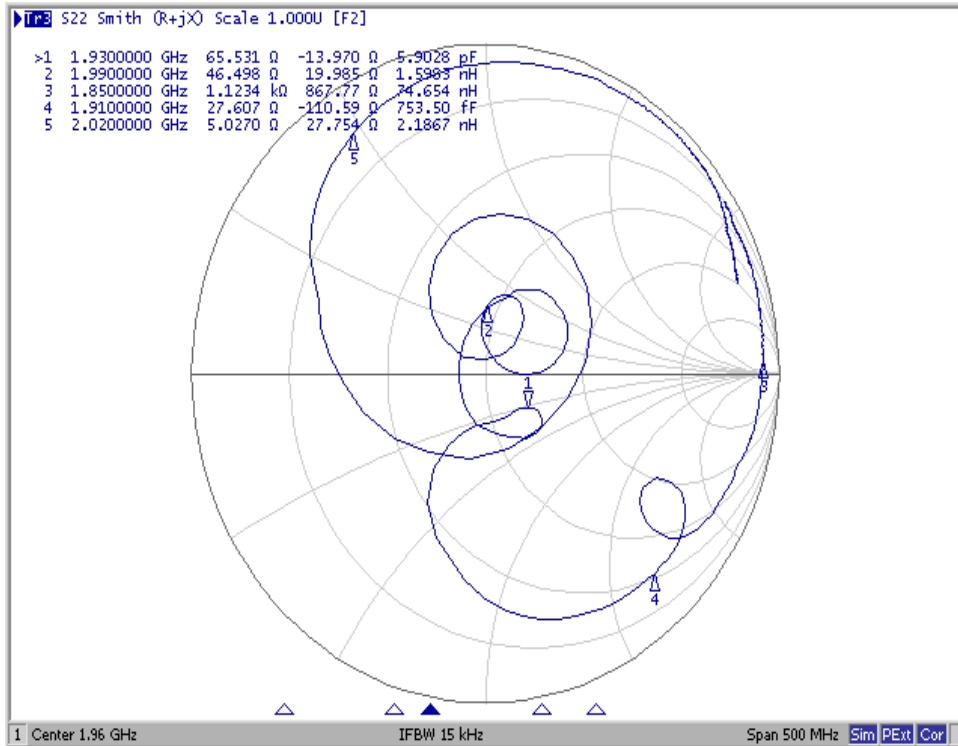

D. MEASUREMENT CIRCUIT:

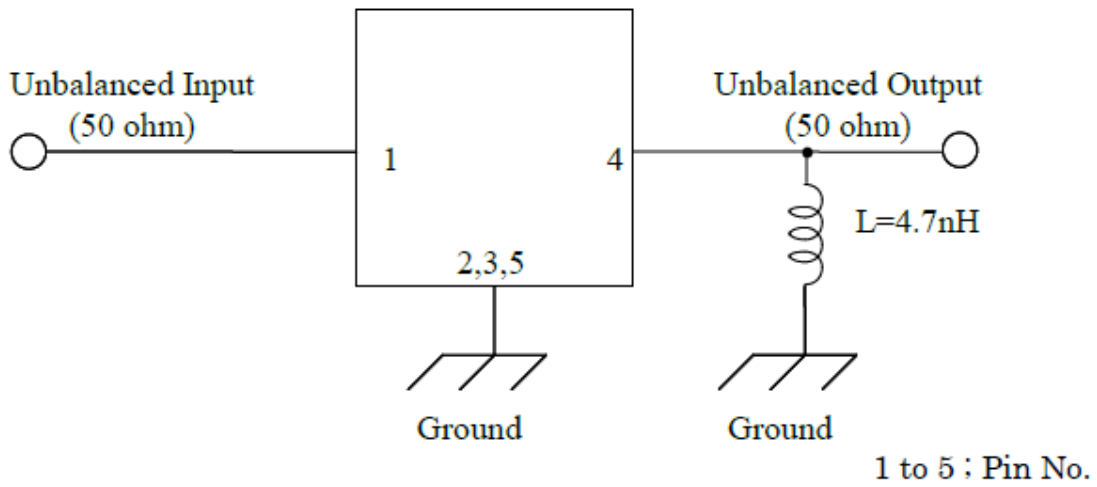

E. OUTLINE DRAWING:

Device size: 1.1typ. x 0.9typ. x 0.5max.

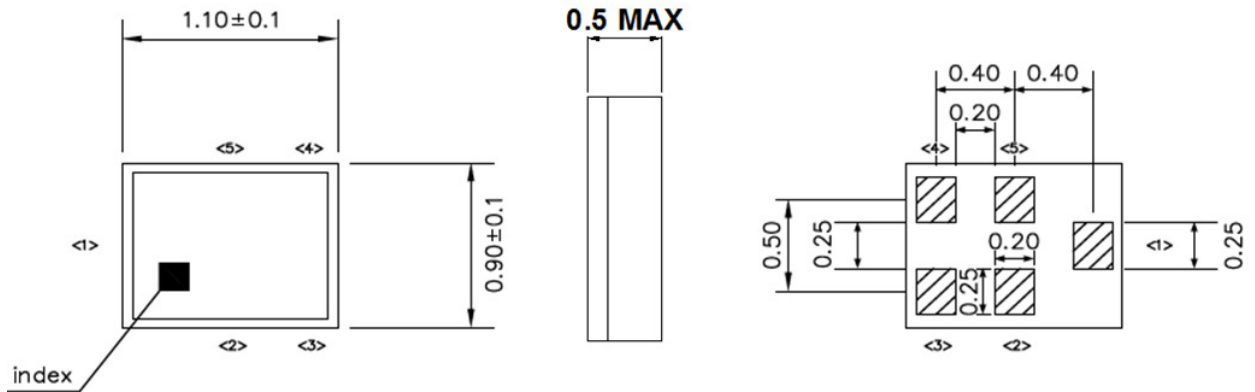

Unit : mm

Pin Configuration

Pin No.	Symbol	Function
1	IN	Unbalanced pin
2	GND	Ground
3	GND	Ground
4	OUT	Unbalanced pin
5	GND	Ground

Top View (Sample Production):

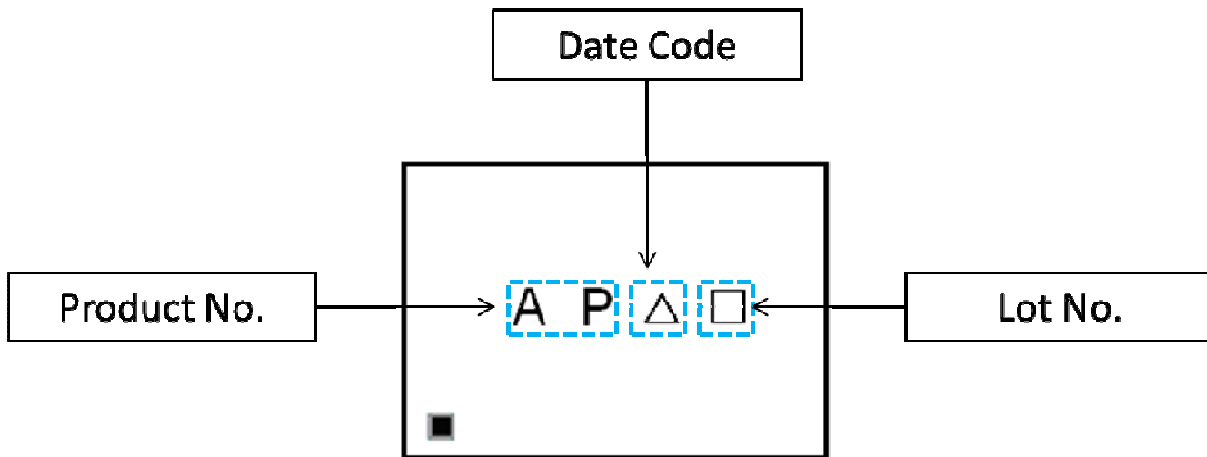

Top View (Mass Production):

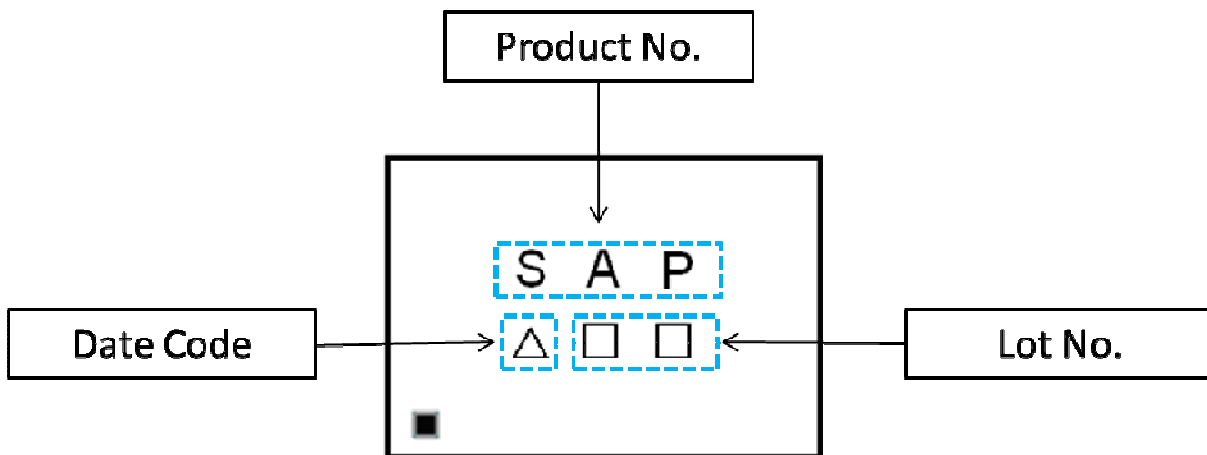

△ : Date Code

□ : Lot No. (Indicated by 0~9 or A to Z and a to z, except I, O, i, o and l)

Product date Code (EIAJ)

Year	Jan	Feb	Mar	Apr	May	Jun	Jul	Aug	Sep	Oct	Nov	Dec
2015	a	b	c	d	e	f	g	h	j	k	l	m
2016	n	p	q	r	s	t	u	v	w	x	y	z
2017	A	B	C	D	E	F	G	H	J	K	L	M
2018	N	P	Q	R	S	T	U	V	W	X	Y	Z

F. PACKING:

1. REEL DIMENSION

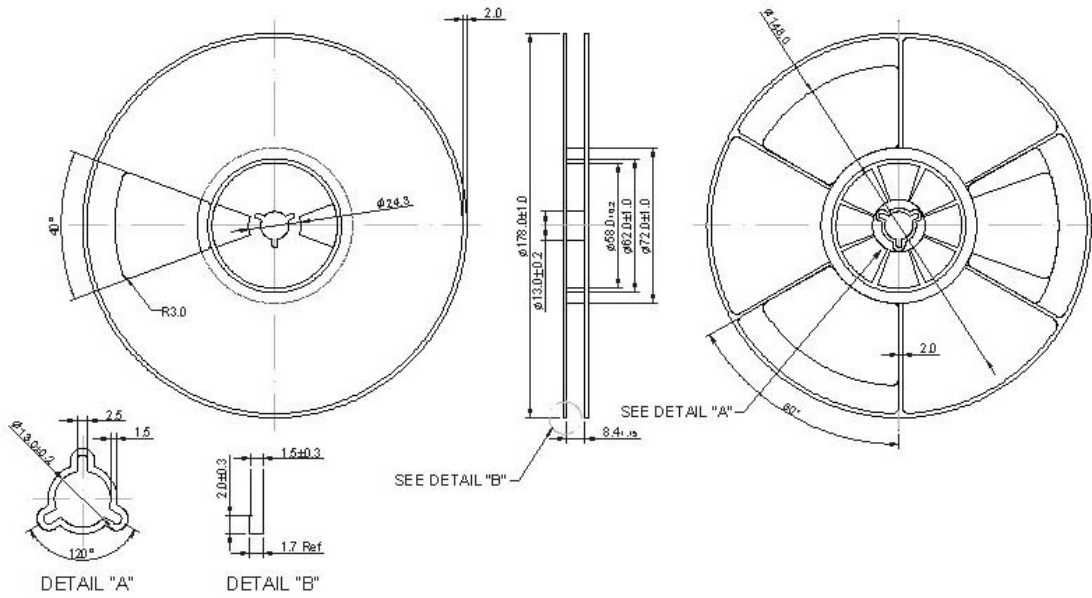

2. TAPE DIMENSION

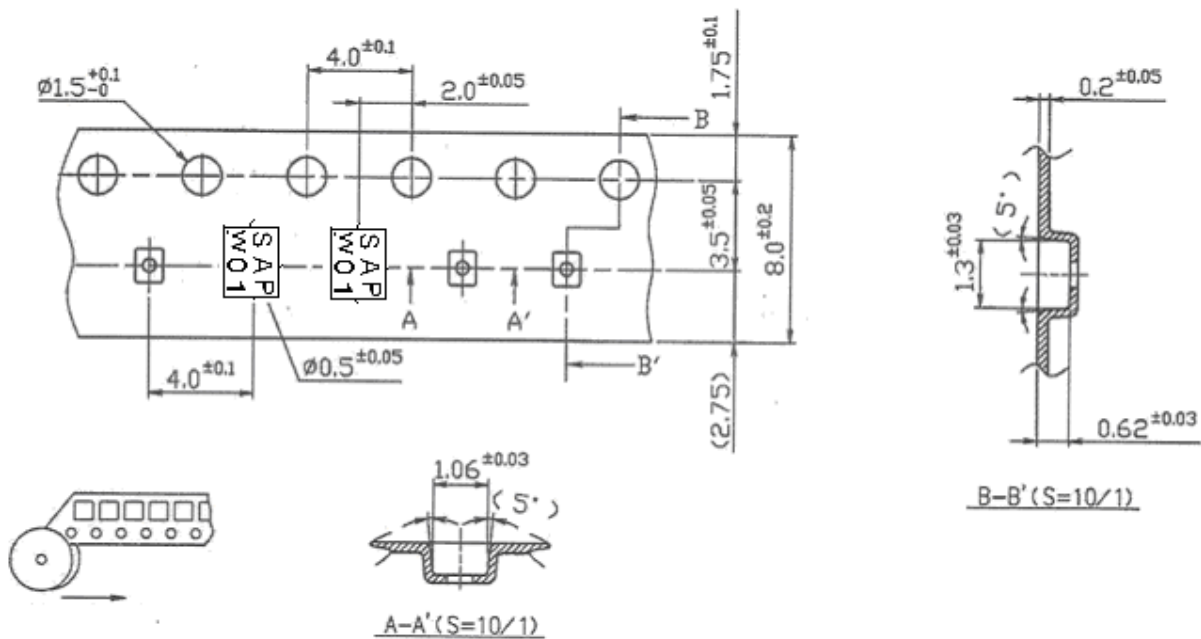

G. RECOMMENDED REFLOW PROFILE:

1. Preheating shall be fixed at 150~180°C for 60~90 seconds.
2. Ascending time to preheating temperature 150°C shall be 30 seconds min.
3. Heating shall be fixed at 220°C for 50~80 seconds and at 260°C+0/-5°C peak (20~40sec).
4. Time: 2 times.

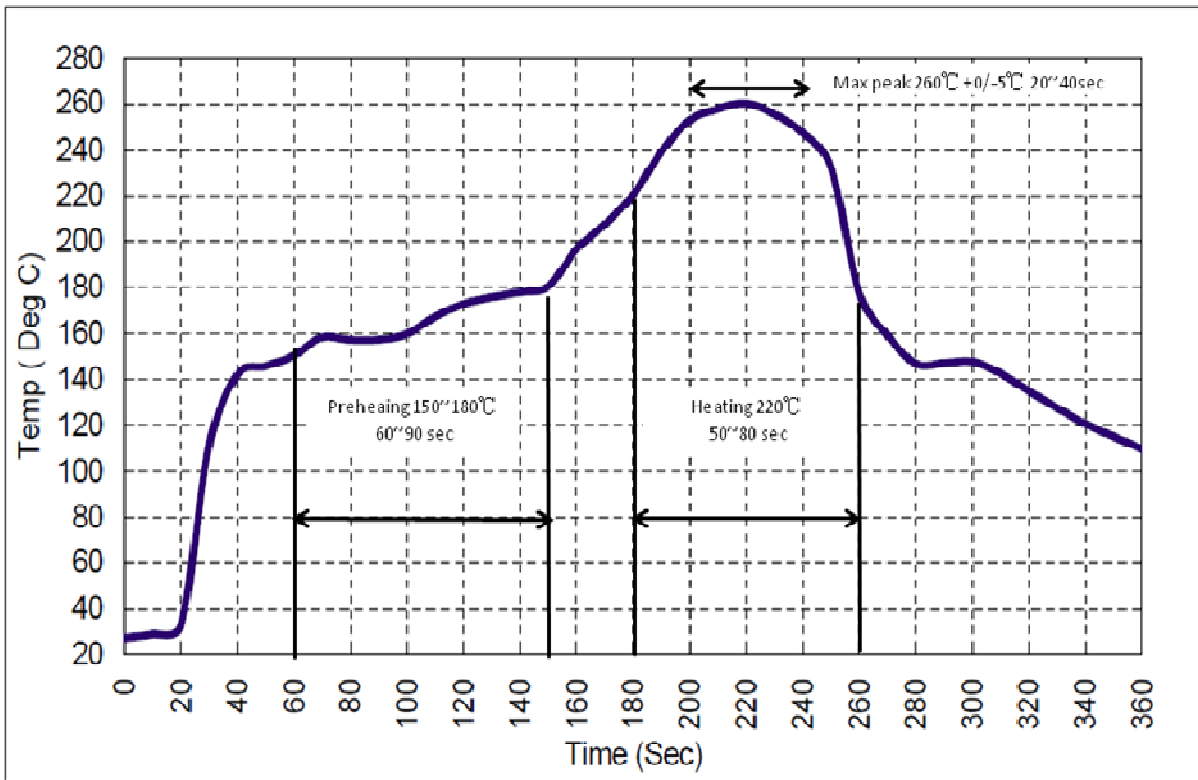

X-ON Electronics

Largest Supplier of Electrical and Electronic Components

Click to view similar products for [Signal Conditioning](#) category:

Click to view products by [Tai-Saw Technology](#) manufacturer:

Other Similar products are found below :

[MAPDCC0001](#) [MAPDCC0004](#) [PD0409J5050S2HF](#) [HHS-109-PIN](#) [AFS14A30-2185.00-T3](#) [AFS14A35-1591.50-T3](#) [DS-323-PIN](#) [DSS-313-PIN](#) [B39321R801H210](#) [1A0220-3](#) [JP510S](#) [LFB212G45SG8C341](#) [LFB322G45SN1A504](#) [LFL182G45TC3B746](#) [SF2159E](#) [30057](#)
[AFS1575.42S4-T](#) [FM-104-PIN](#) [CER0813B](#) [MAPDCC0005](#) [3A325](#) [40287](#) [41180](#) [ATB3225-75032NCT](#) [BD0810N50100AHF](#) [JHS-115-PIN](#)
[DC0710J5005AHF](#) [DC2327J5005AHF](#) [43020](#) [LFB2H2G60BB1C106](#) [LFL15869MTC1B787](#) [X3C19F1-20S](#) [XC3500P-20S](#) [10013-20](#)
[SF2194E](#) [CDBLB455KCAX39-B0](#) [TGL2208-SM, EVAL](#) [RF1353C](#) [051157-0000](#) [PD0922J5050D2HF](#) [1E1305-3](#) [1F1304-3S](#) [1G1304-30](#)
[B0922J7575AHF](#) [10017-3](#) [TP-103-PIN](#) [BD1222J50200AHF](#) [BD1722J50100AHF](#) [2450DP39K5400E](#) [BD0810J50150AHF](#)