



TAI-SAW TECHNOLOGY CO., LTD.

No. 3, Industrial 2nd Rd., Ping-Chen Industrial District,
Taoyuan, 324, Taiwan, R.O.C.

TEL: 886-3-4690038 FAX: 886-3-4697532

E-mail: tstsales@mail.taisaw.com Web: www.taisaw.com

Product Specifications Approval Sheet

Product Description: SAW Filter 1600 MHz (BW 20MHz) SMD 3.0X3.0 mm

TST Part No.: TA2268A (This part is is compliant with AEC-Q200)

Customer Part No.: _____

Customer signature required
Company: _____
Division: _____
Approved by : _____
Date: _____

Checked by: _____ Michael Yang *Michael*

Approval by: _____ Andy Yu *Andy Yu*

Date: _____ 2018/01/22

1. Customer signed back is required before TST can proceed with sample build and receive orders.
2. Orders received without customer signed back will be regarded as agreement on the specifications.
3. Any specifications changes must be approved upon by both parties and a new revision of specifications shall be released to reflect the changes.



TAI-SAW TECHNOLOGY CO., LTD.

No. 3, Industrial 2nd Rd., Ping-Chen Industrial District,
Taoyuan, 324, Taiwan, R.O.C.

TEL: 886-3-4690038 FAX: 886-3-4697532

E-mail: tstsales@mail.taisaw.com Web: www.taisaw.com

SAW Filter 1600MHz

MODEL NO.:TA2268A

REV. NO.:1.0

A. MAXIMUM RATING:

1. Input Power Level: 15 dBm
2. DC Voltage : 0V
3. Operating Temperature: -40°C to +85°C
4. Storage Temperature: -40°C to +105°C
5. Moisture Sensitive Level (MSL): Level 1

RoHS Compliant
Lead free
Lead-free soldering

Electrostatic Sensitive Device (ESD)

Moisture Sensitivity Level: 1

B. ELECTRICAL CHARACTERISTICS:

Terminating source impedance (single) : $Z_s = 50 \Omega$

Terminating load impedance(single) : $Z_L = 50 \Omega$

Item	Unit	Min	Typ.	Max
Center Frequency F_c	MHz	-	1600	-
Insertion Loss (1590~1610 MHz) IL	dB		2.5	3.5
Amplitude ripple(1590~1610 MHz)	dB		1.0	1.8
Group Delay Ripple(1590~1610 MHz)	nS		7	15
Attenuation				
50 ~ 1545 MHz	dB	40	45	
1645 ~ 2400 MHz	dB	40	45	
Temperature Coefficient	ppm/K	-36		
Package size	mm	SMD 3.0x3.0		

C. TEST CIRCUIT:

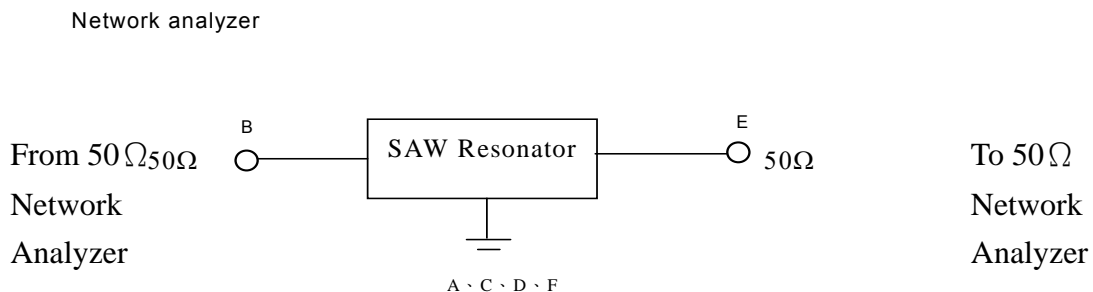

D.OUTLINE DRAWING:

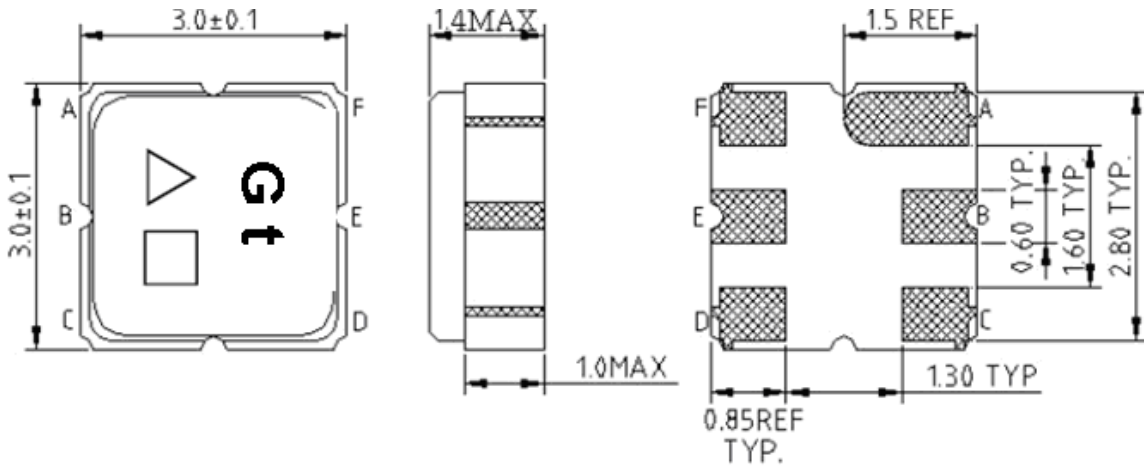

- #B: Input
- #E: Output
- # A.C.D.F Ground
- △:Year code (ex 2008→8)
- : Date code
- Unit: mm

Data code : See the table

WK	01	02	...	26	27	28	...	52
Code	A	B	...	Z	a	b	...	z

△ Year code : See the table

Year	2008	2009	2010	2011	...	2019	2020
Code	8	9	0	1	...	9	0

E.FOOT PRINT:

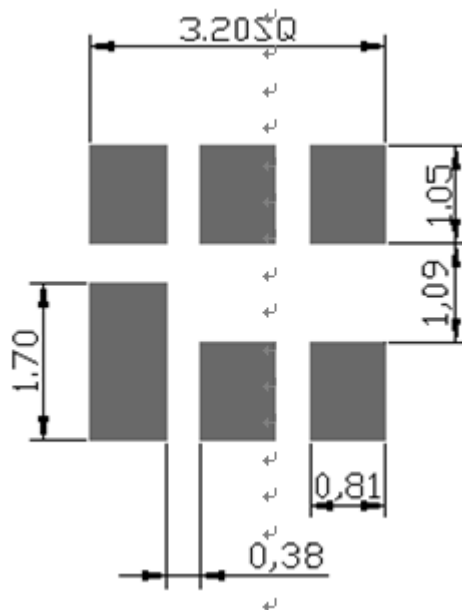

F. Frequency Characteristics:
S21 response: (span 400MHz)

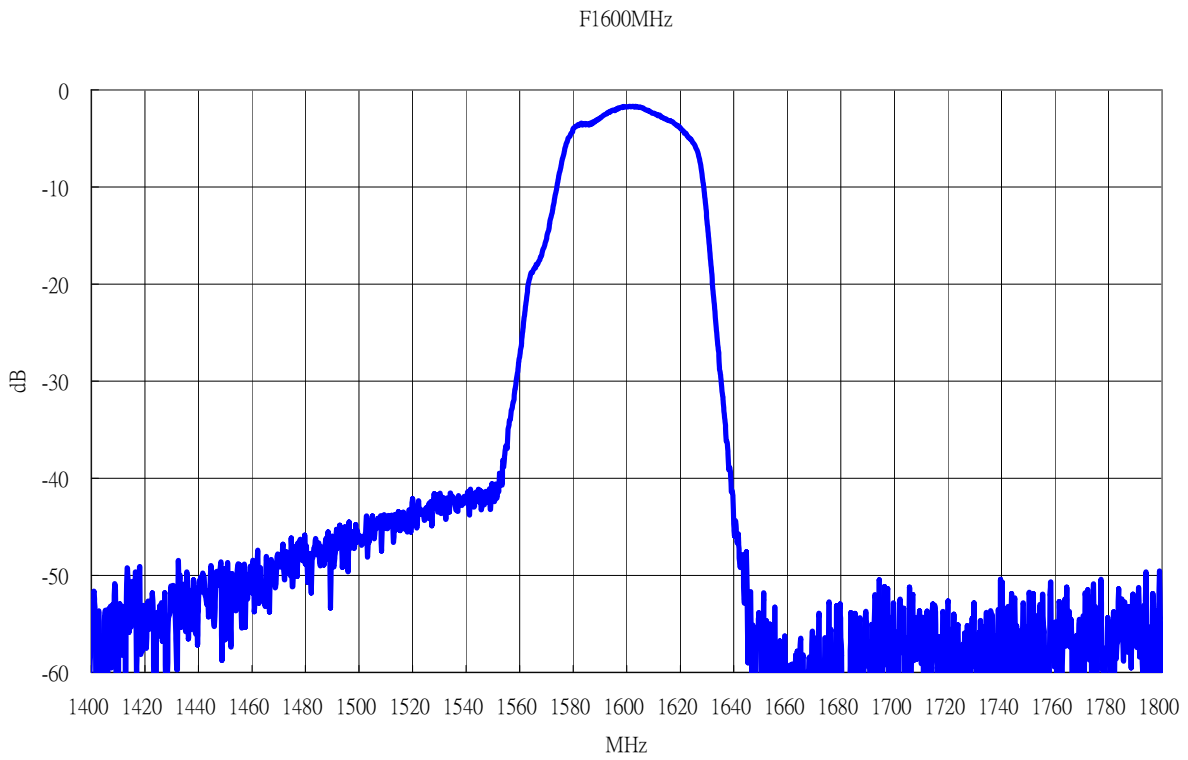

S21 response: (span 80MHz)

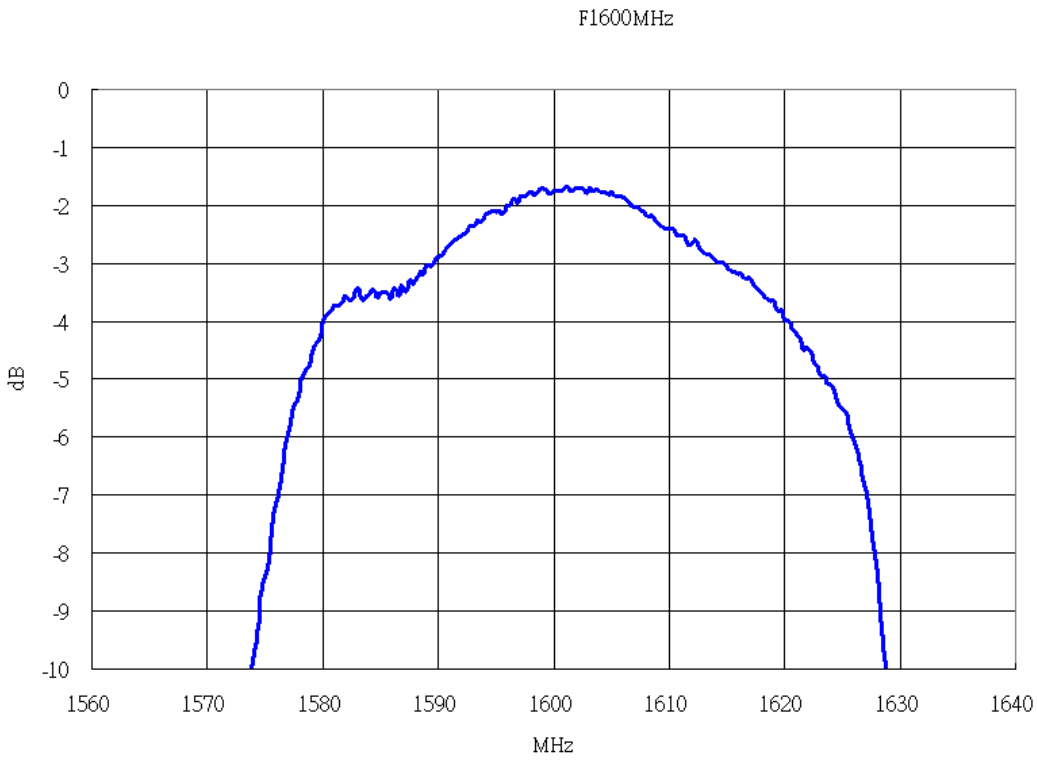

S21 response: (span 3GHz)

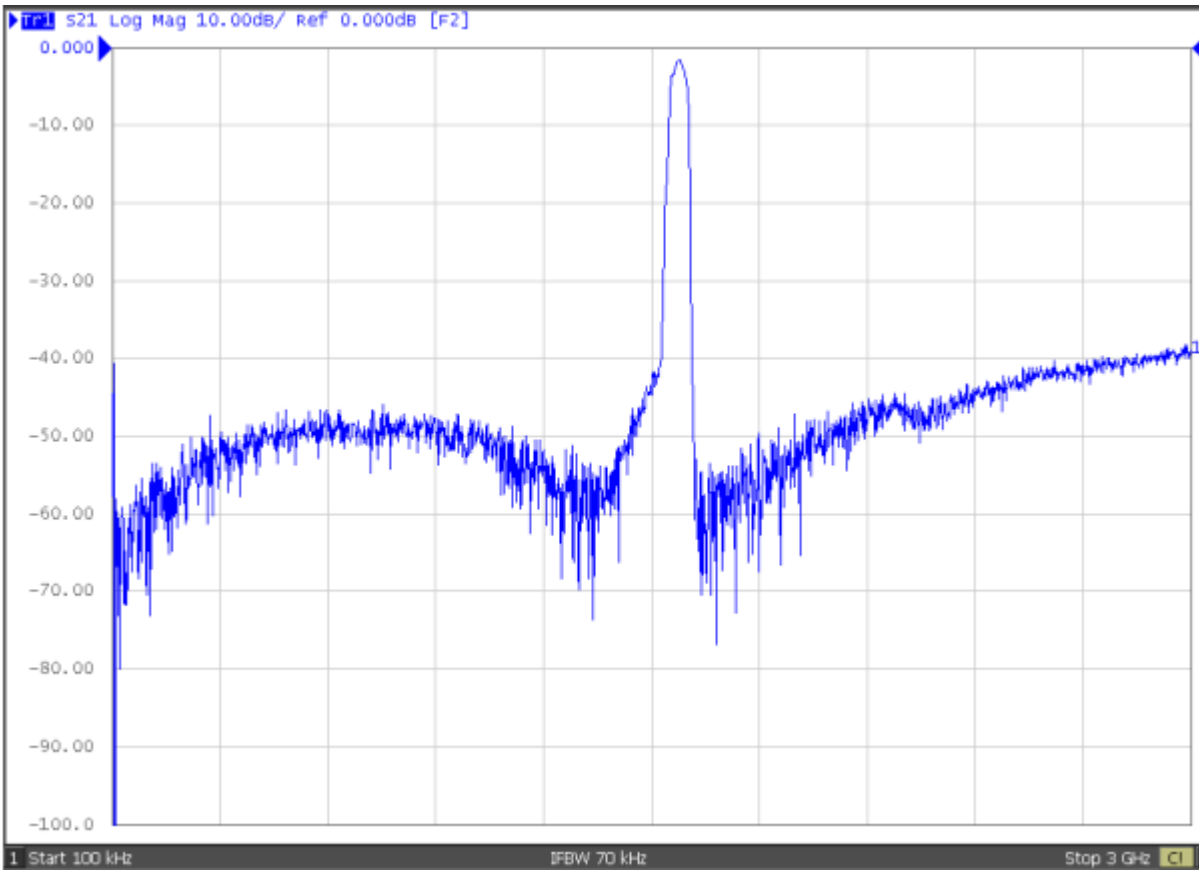

S11/S22 response :

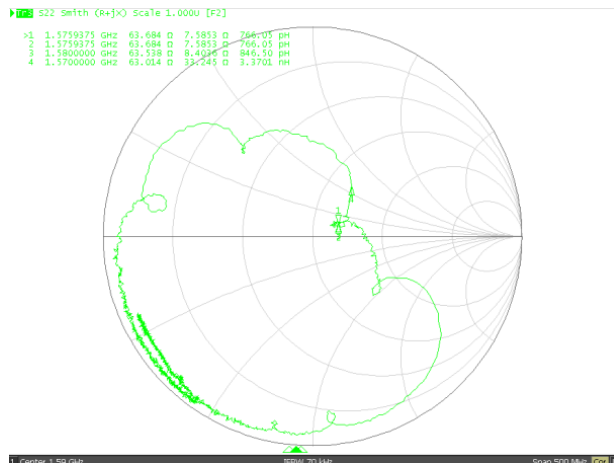
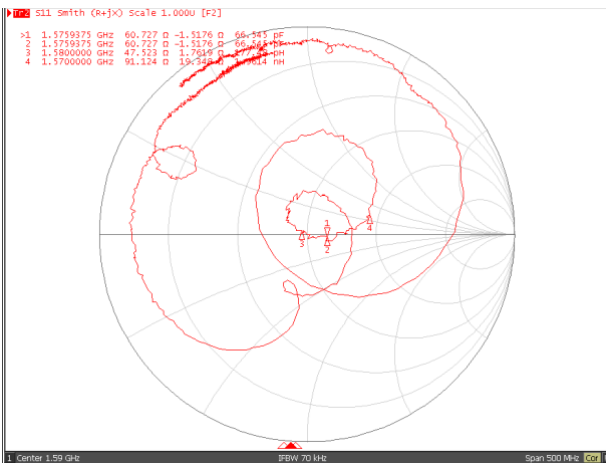

G. PACKING:

1. REEL DIMENSION

(Please refer to FR-75D10 for packing quantity)

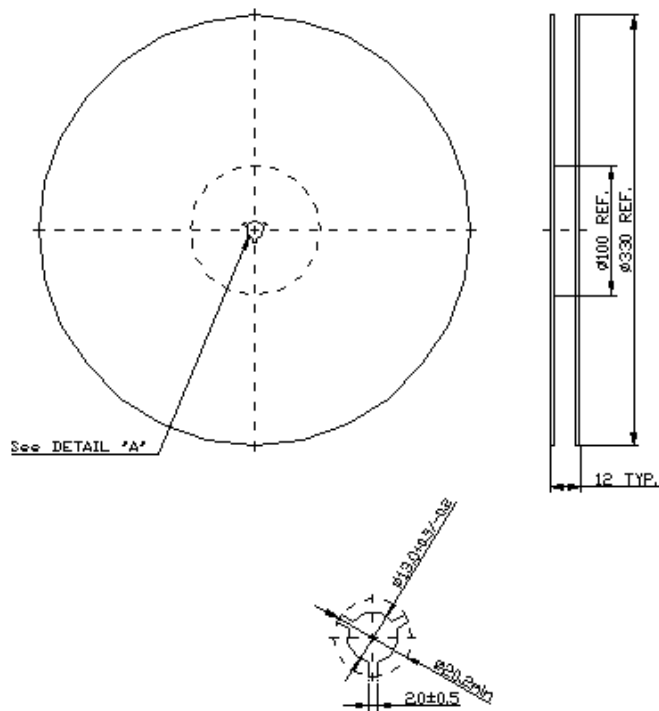

2. TAPE DIMENSION

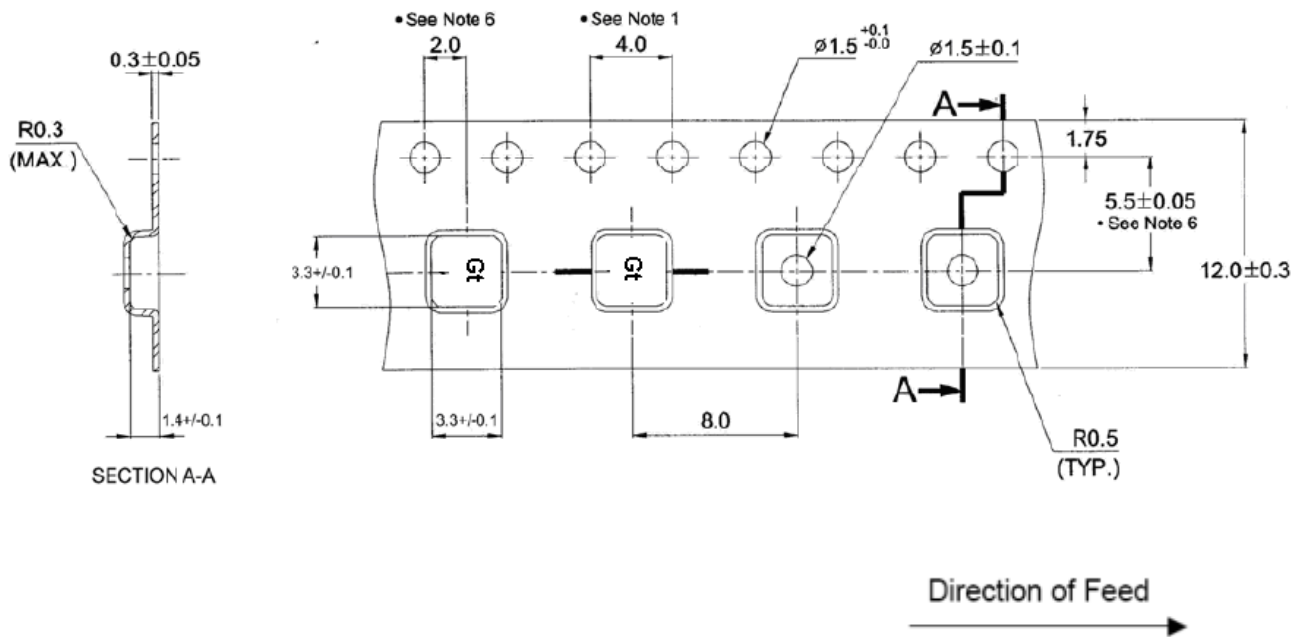

H. Recommended Reflow Profile:

1. Preheating shall be fixed at 150~180°C for 60~90 seconds.
2. Ascending time to preheating temperature 150°C shall be 30 seconds min.
3. Heating shall be fixed at 220°C for 50~80 seconds and at 260°C +0/-5°C peak (20~40sec).
4. Time: 2 times.

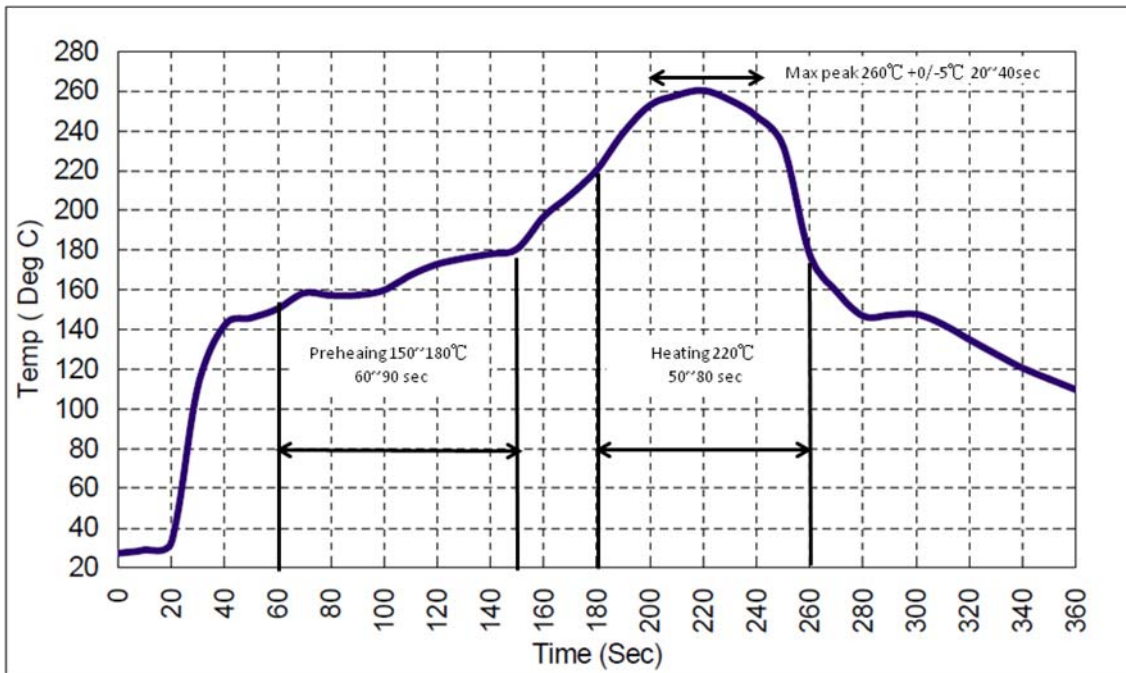

X-ON Electronics

Largest Supplier of Electrical and Electronic Components

Click to view similar products for [Signal Conditioning](#) category:

Click to view products by [Tai-Saw Technology](#) manufacturer:

Other Similar products are found below :

[PD0409J5050S2HF](#) [HHS-109-PIN](#) [AFS14A35-1591.50-T3](#) [JP510S](#) [LFB322G45SN1A504](#) [SF2159E](#) [FM-104-PIN](#) [CER0813B](#)

[MAPDCC0005](#) [3A325](#) [BD0810N50100AHF](#) [DC0710J5005AHF](#) [DC2327J5005AHF](#) [LFL15869MTC1B787](#) [X3C19F1-20S](#)

[CDBLB455KCAX39-B0](#) [RF1353C](#) [051157-0000](#) [PD0922J5050D2HF](#) [600S150FTRB](#) [1E1305-3](#) [1F1304-3S](#) [TP-103-PIN](#)

[BD1222J50200AHF](#) [BD1722J50100AHF](#) [2450DP39K5400E](#) [BD0810J50150AHF](#) [BD1722J50200AHF](#) [DS-327-PIN](#) [MACP-008125-](#)

[CK07F0](#) [DS-329-PIN](#) [DS-313-PIN](#) [TP-104-PIN](#) [TP-101-PIN](#) [HH-128-PIN](#) [8594810000](#) [T-1000-N](#) [JP506S](#) [XC0900P-10S](#) [XC0900B-30S](#)

[CHE1260-QAG](#) [11305-10](#) [5962-9091202MXA](#) [3A412S](#) [X3C06A4-03S](#) [B39000Z3410A4](#) [DSS-333-PIN](#) [PD2425J5050S2HF](#)

[B39242B4360P810](#) [B39781B8005P810](#)