



TAI-SAW TECHNOLOGY CO., LTD.

No. 3, Industrial 2nd Rd., Ping-Chen Industrial District,
Taoyuan, 324, Taiwan, R.O.C.

TEL: 886-3-4690038 FAX: 886-3-4697532

E-mail: tstsales@mail.taisaw.com Web: www.taisaw.com

Product Specifications Approval Sheet

Product Name: Duplexer 836.5/881.5MHz 25MHz BW SMD 2.0x1.6 mm

TST Parts No.: TF0089A

Customer Part No.: _____

Customer signature required
Company: _____
Division: _____
Approved by : _____
Date: _____

Checked by: _____ Andy Yu 

Approved by: _____ Bob Chau 

Date: _____ 2013, 11, 13

1. Customer signed back is required before TST can proceed with sample build and receive orders.
2. Orders received without customer signed back will be regarded as agreement on the specifications.
3. Any specifications changes must be approved upon by both parties and a new revision of specifications shall be released to reflect the changes



TAI-SAW TECHNOLOGY CO., LTD.

No. 3, Industrial 2nd Rd., Ping-Chen Industrial District,
Taoyuan, 324, Taiwan, R.O.C.

TEL: 886-3-4690038 FAX: 886-3-4697532

E-mail: tstsales@mail.taisaw.com Web: www.taisaw.com

SAW Duplexer 836.5/881.5MHz 25MHz BW SMD 2.0×1.6 mm

MODEL NO.: TF0089A

REV. No.: 1.0

A. MAXIMUM RATING:

1. Maximum Input Power: 29 dBm
2. DC voltage: 0 V
3. Operating Temperature: -30°C to +85°C
4. Storage Temperature: -40°C to +85°C

RoHS Compliant

Lead-free soldering

B. ELECTRICAL CHARACTERISTICS:

Tx to Ant		Specifications			
		Unit	Minimum	Typical	Maximum
Parameters Description	Condition [MHz]				
Insertion Loss	824.0 ~ 849.0	dB	-	1.4	1.9
Ripple	824.0 ~ 849.0	dB _{p-p}	-	0.4	1.0
VSWR of Ant Port	824.0 ~ 849.0	-	-	1.5	2.0
VSWR of Tx Port	824.0 ~ 849.0	-	-	1.6	2.0
Attenuation	779.0 ~ 804.0	dB	30	39	-
	869.0 ~ 894.0	dB	45	51	-
	1574.0 ~ 1577.0	dB	45	48	-
	1648.0 ~ 1698.0	dB	45	48	-
	2472.0 ~ 2547.0	dB	25	33	-

Ant to Rx		Specifications			
Parameters Description	Condition [MHz]	Unit	Minimum	Typical	Maximum
Insertion Loss	869.0 ~ 894.0	dB	-	1.7	2.2
Ripple	869.0 ~ 894.0	dB _{p-p}	-	0.4	1.1
VSWR of Ant Port	869.0 ~ 894.0	-	-	1.6	2.0
VSWR of Rx Port	869.0 ~ 894.0	-	-	1.6	2.0
Attenuation	824.0 ~ 849.0	dB	51	58	-
	1738.0 ~ 1788.0	dB	40	54	-
	1850.0 ~ 1910.0	dB	40	54	-
	1920.0 ~ 1980.0	dB	40	53	-
	2400.0 ~ 2500.0	dB	40	52	-
	3476.0 ~ 3576.0	dB	40	49	-
Amplitude balance(S ₃₁ /S ₄₁)	869.0 ~ 894.0	dB	-1.0	-0.2/+0.2	+1.0
Phase balance $\Phi(S_{31}) - \Phi(S_{41}) + 180^\circ$	869.0 ~ 894.0	deg	-10	-2/+2	+10

Tx to Rx		Specifications			
Parameters Description	Condition [MHz]	Unit	Minimum	Typical	Maximum
Isolation in Tx Band	824.0 ~ 849.0	dB	57	59	-
Isolation in Rx Band	869.0 ~ 894.0	dB	49	52	-

Notes : (1) With Matching Network .

C. Frequency Characteristics :

Tx to Ant

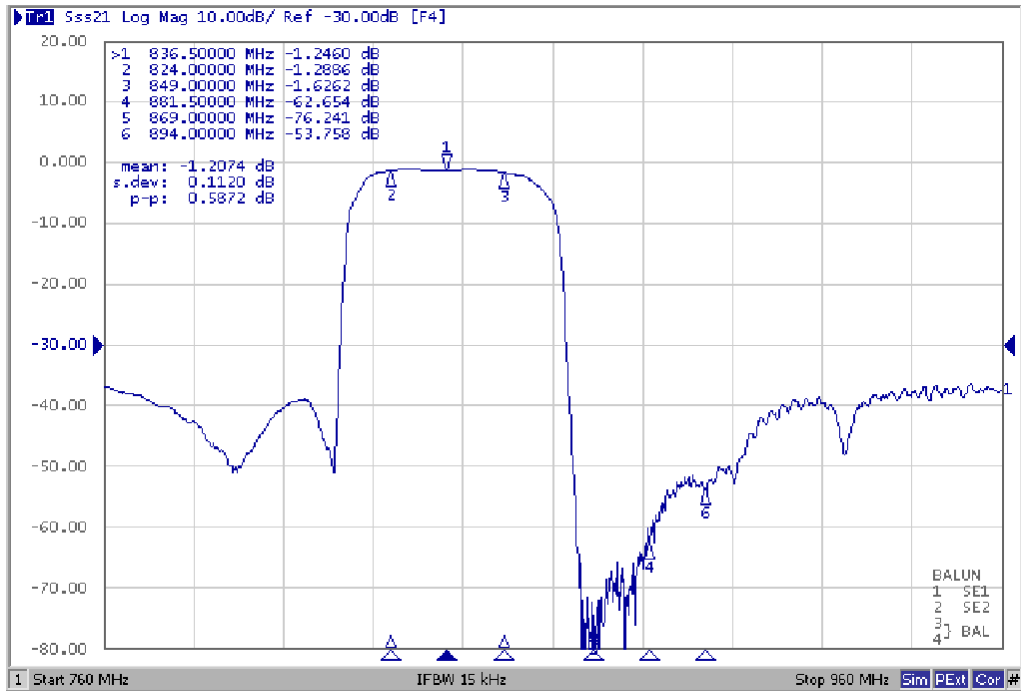

Ant to Rx

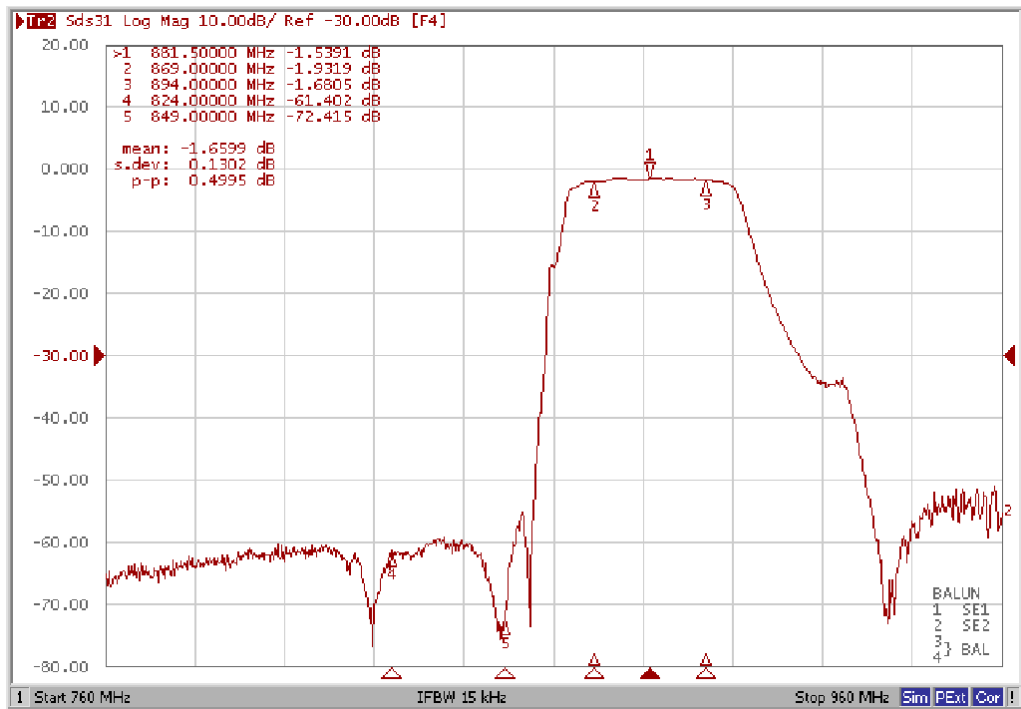

Isolation

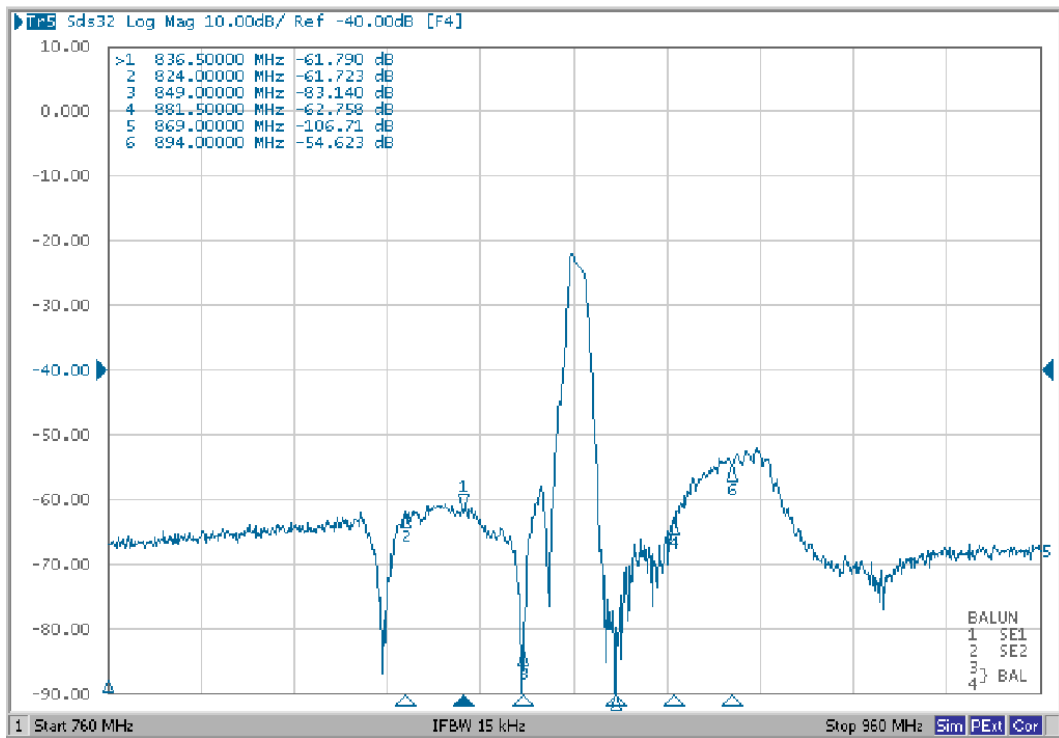

Ripple

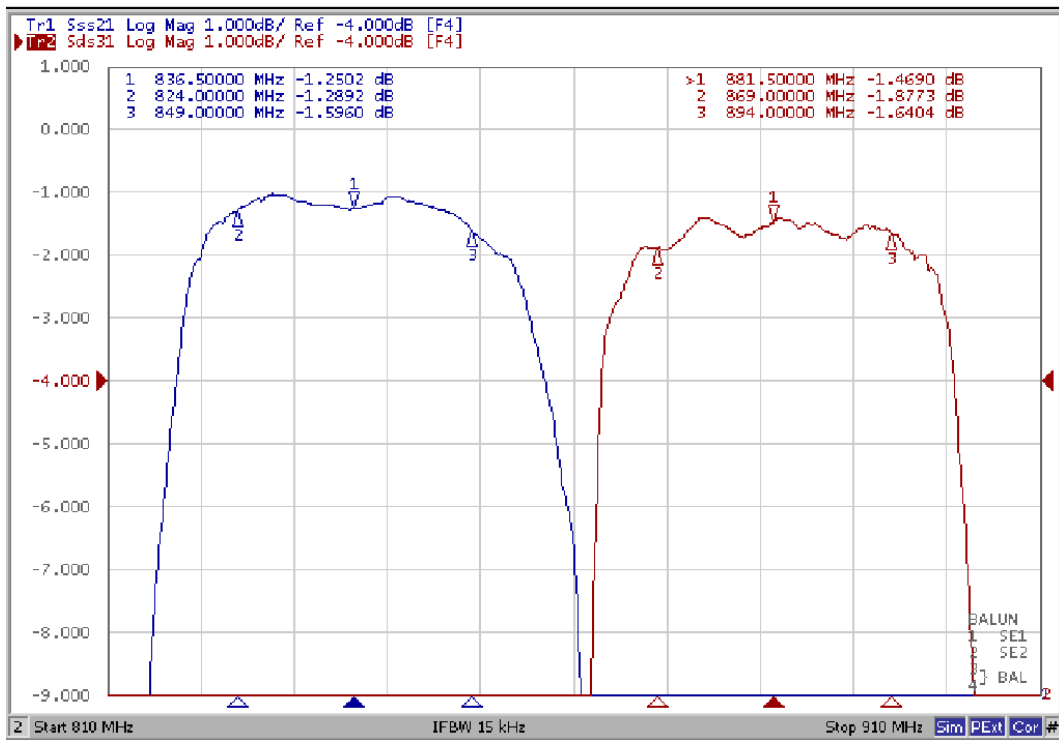

VSWR (Tx Port)

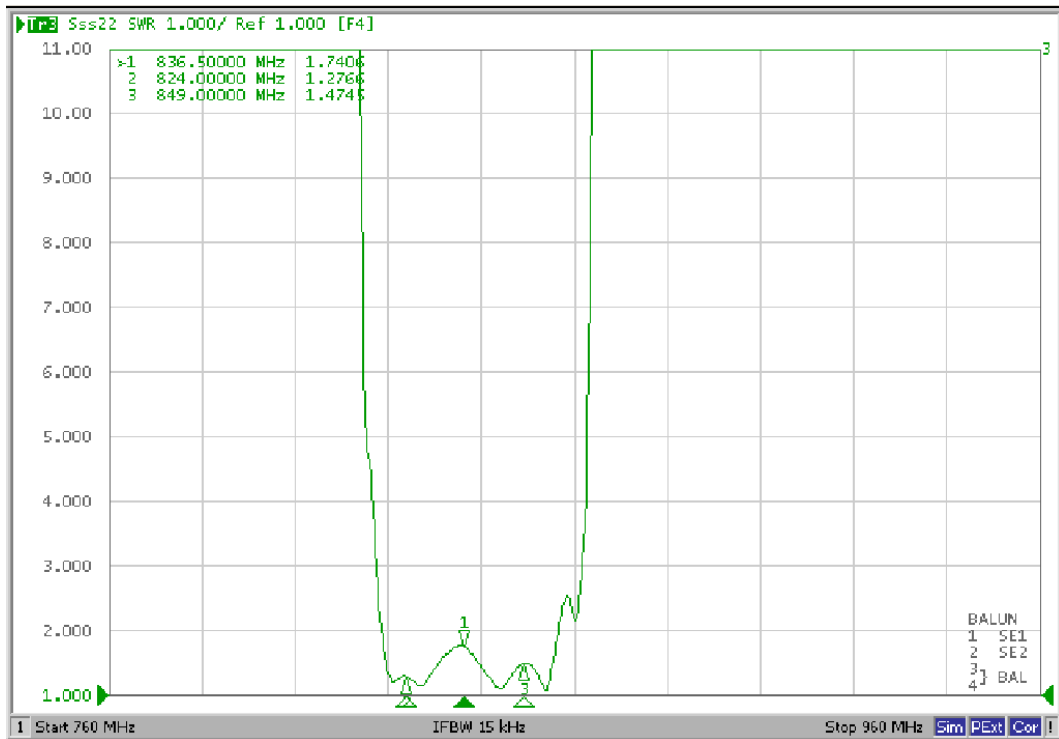

Smith Chart (Tx Port)

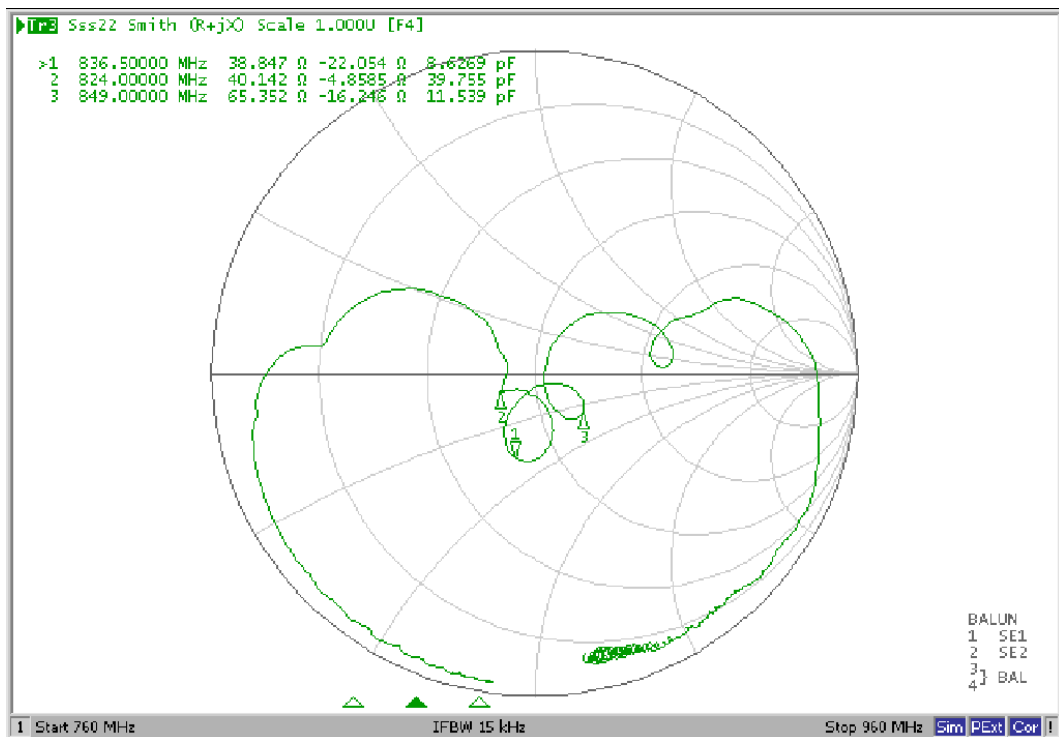

VSWR (Rx Port)

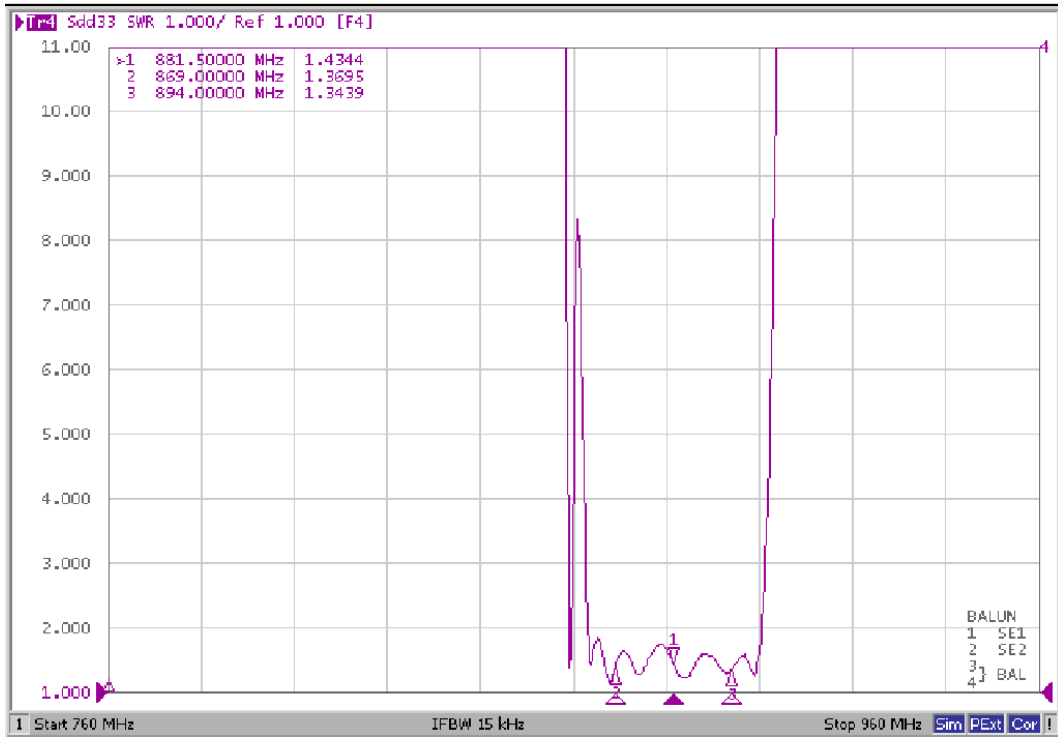

Smith Chart (Rx Port)

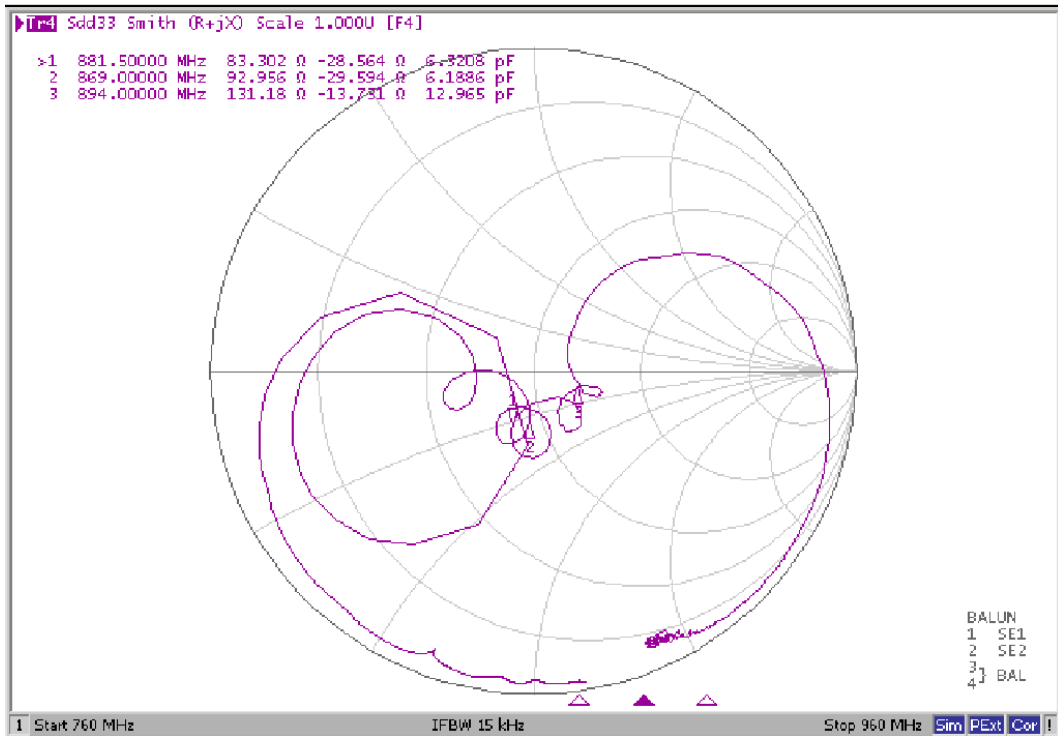

VSWR (ANT Port)

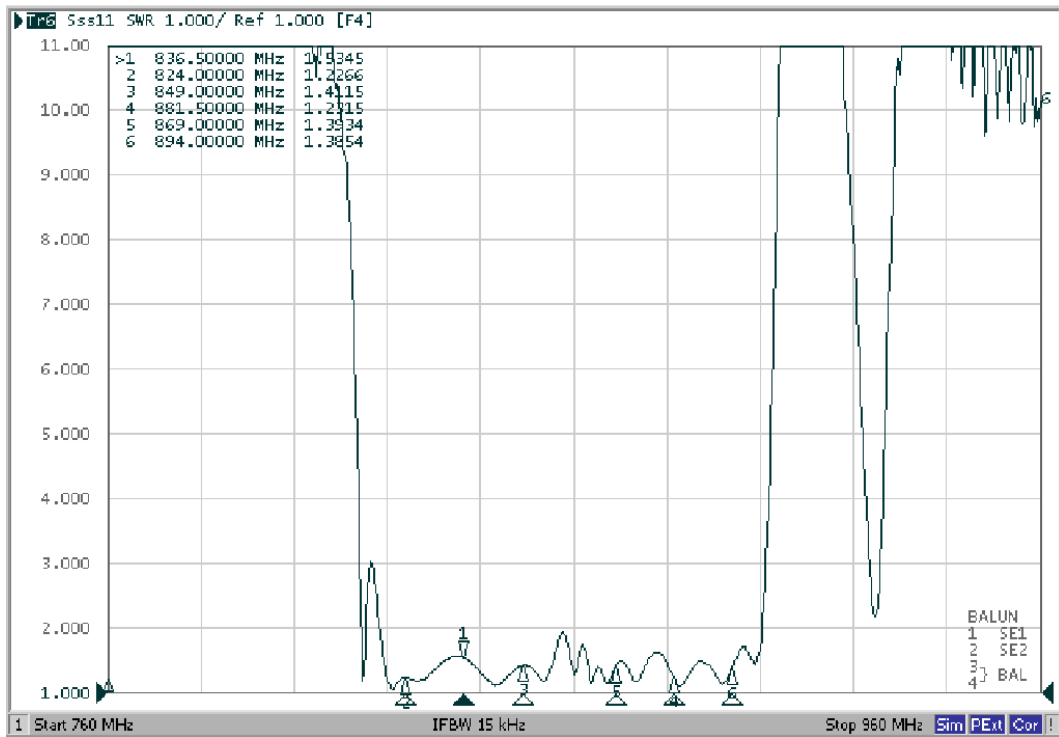

Smith Chart (ANT Port)

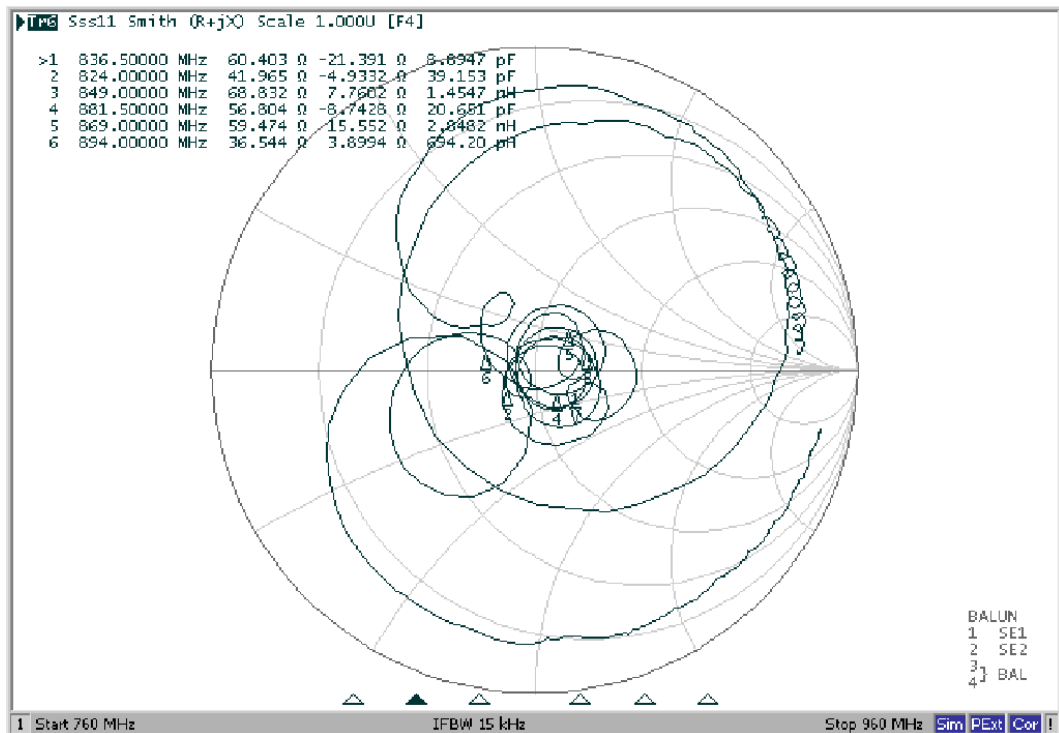

Wide Span

Tx

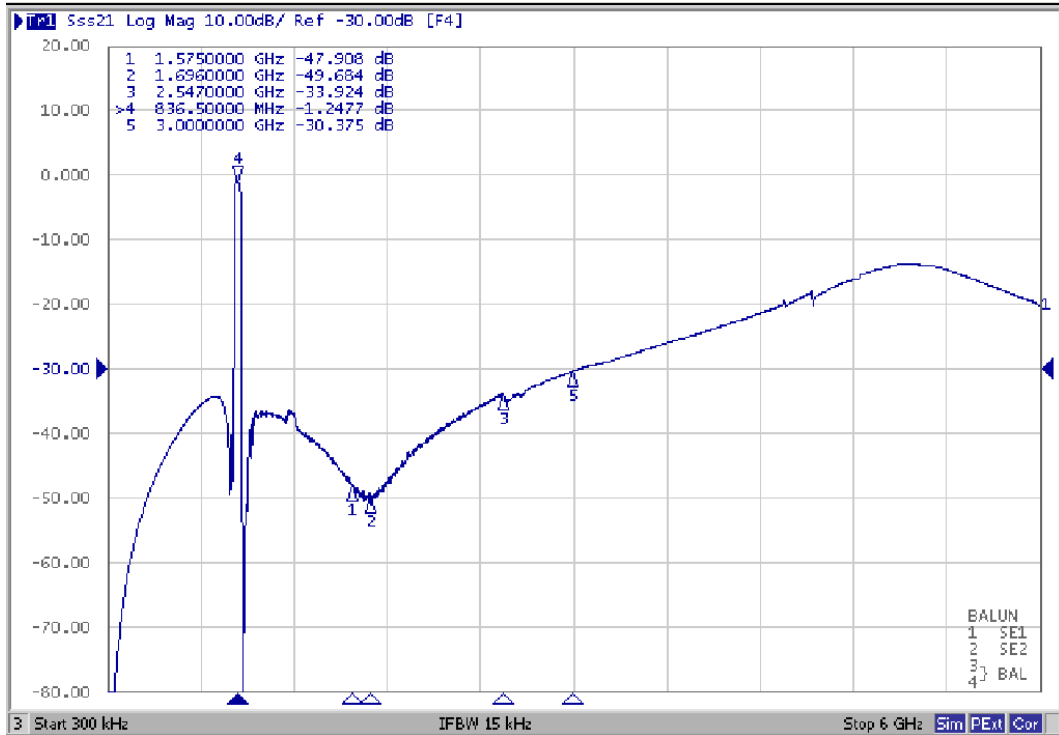

Rx

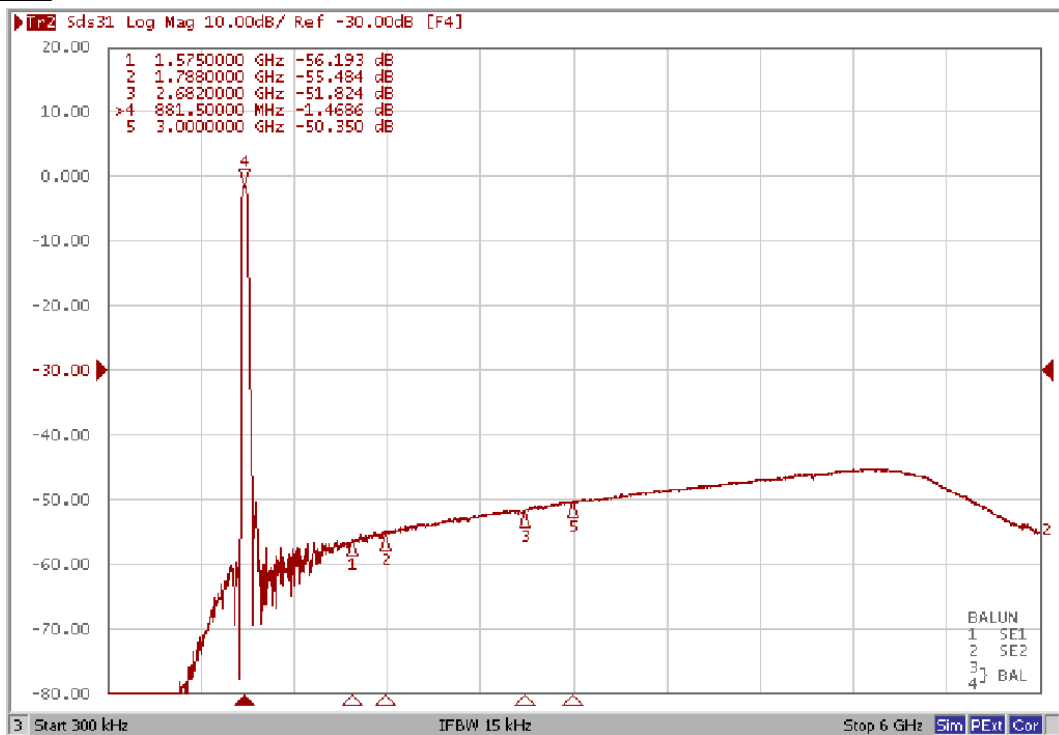

Amplitude balance of Ant to Rx+/Rx-

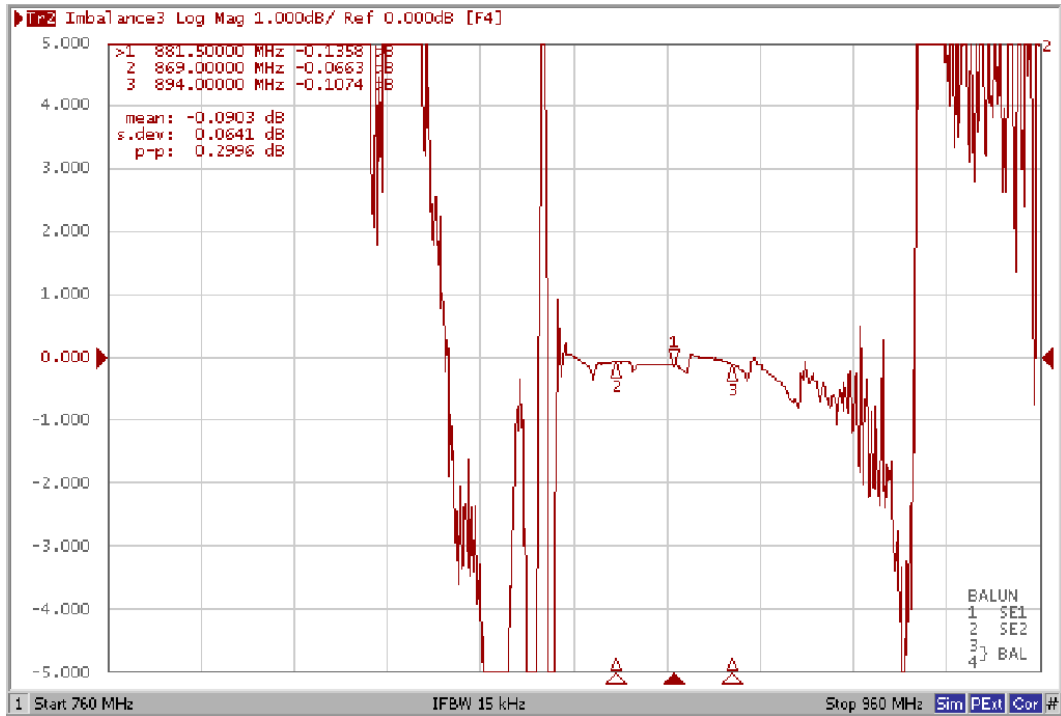

Phase balance of Ant to Rx+/Rx-



D. MEASUREMENT CIRCUIT:

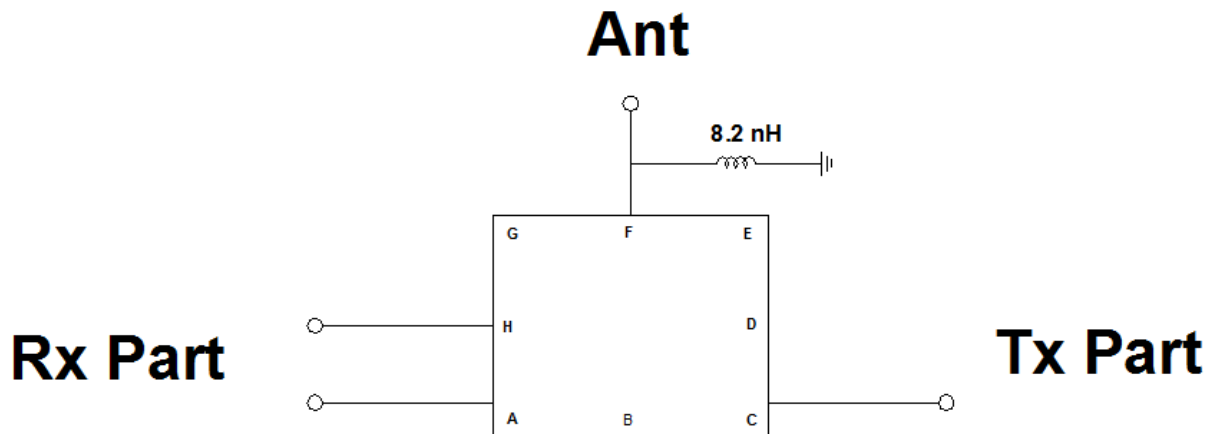

E. OUTLINE DRAWING:

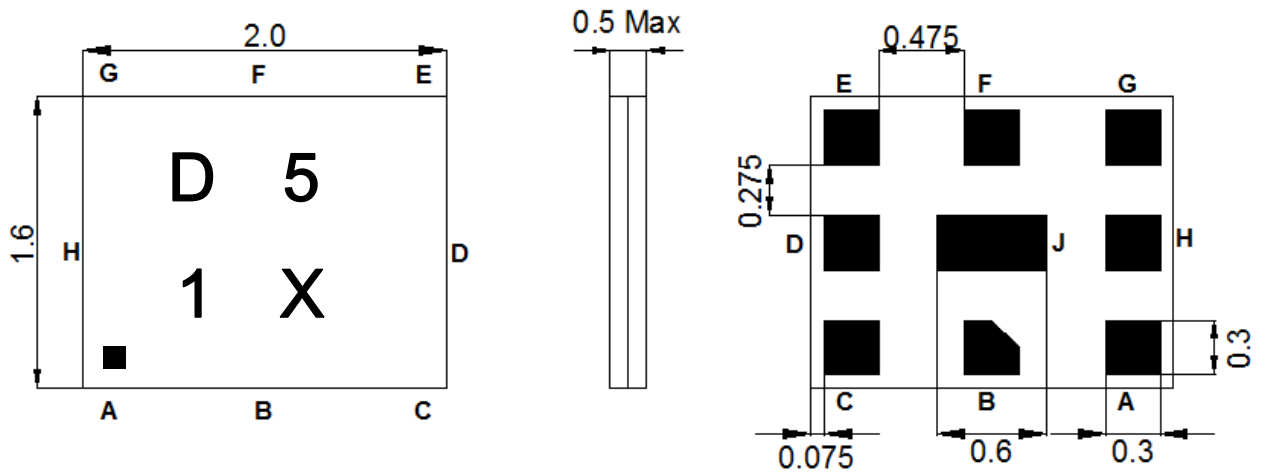

Marking Descriptions	
D	Duplexer Application
5	Band Class
1	Series Number
X	Date Code(Year+Month)

Pin Description	
B,D,E,G,J	Ground
F	Ant
C	Tx (836.5MHz)
A,H	Rx (881.5MHz)

E. PACKING:

1. REEL DIMENSION

(Please refer to FR-75D10 for packing quantity)

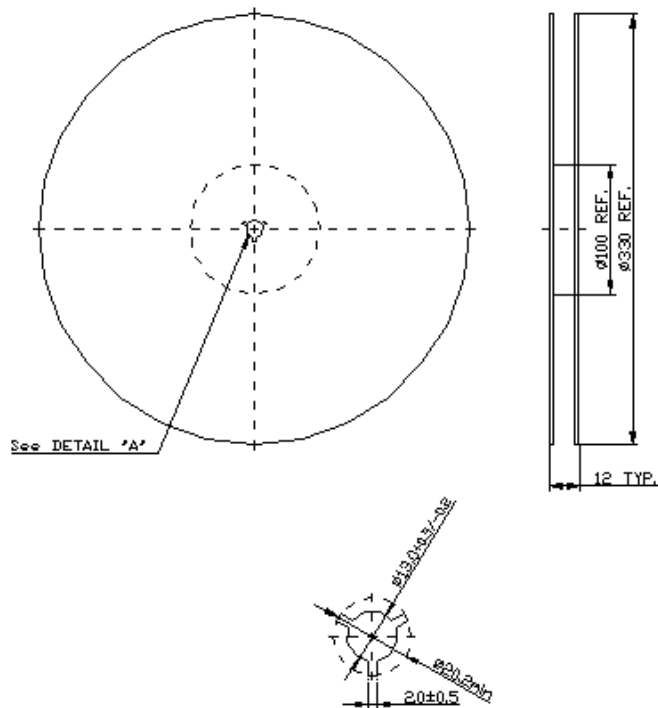

2. TAPE DIMENSION

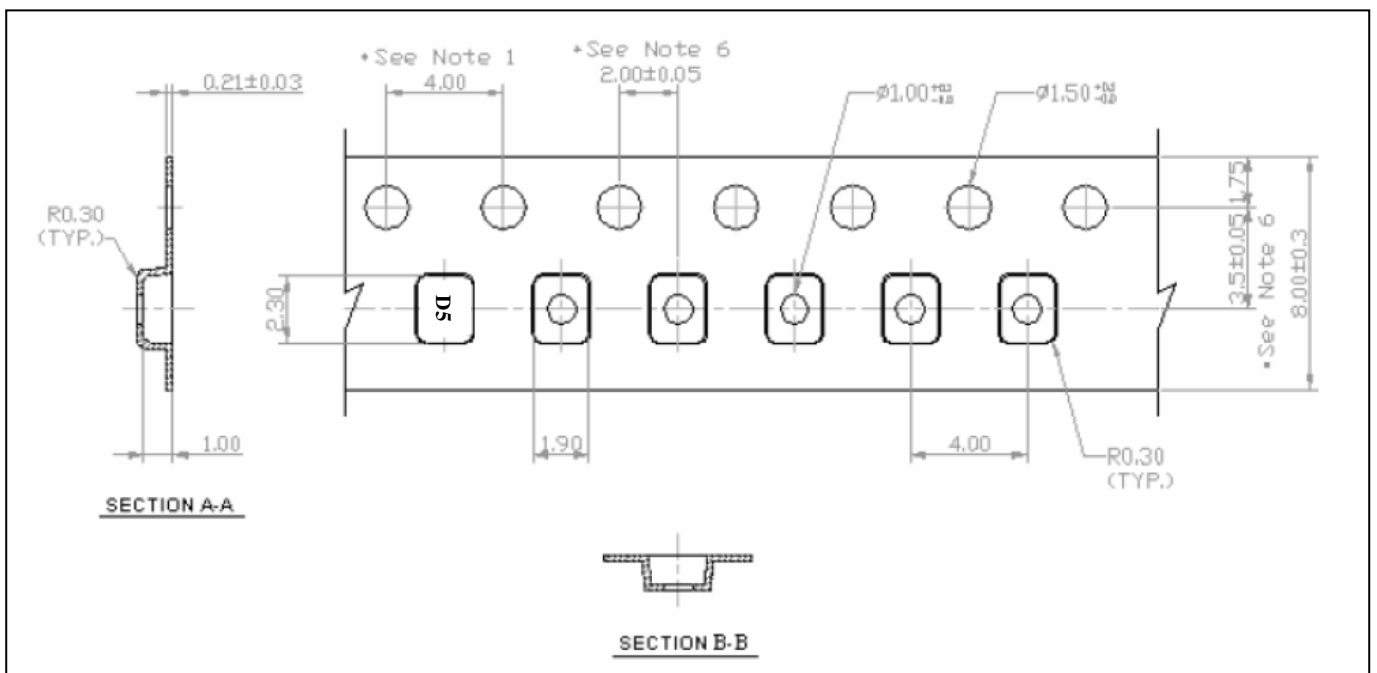

F. RECOMMENDED REFLOW PROFILE :

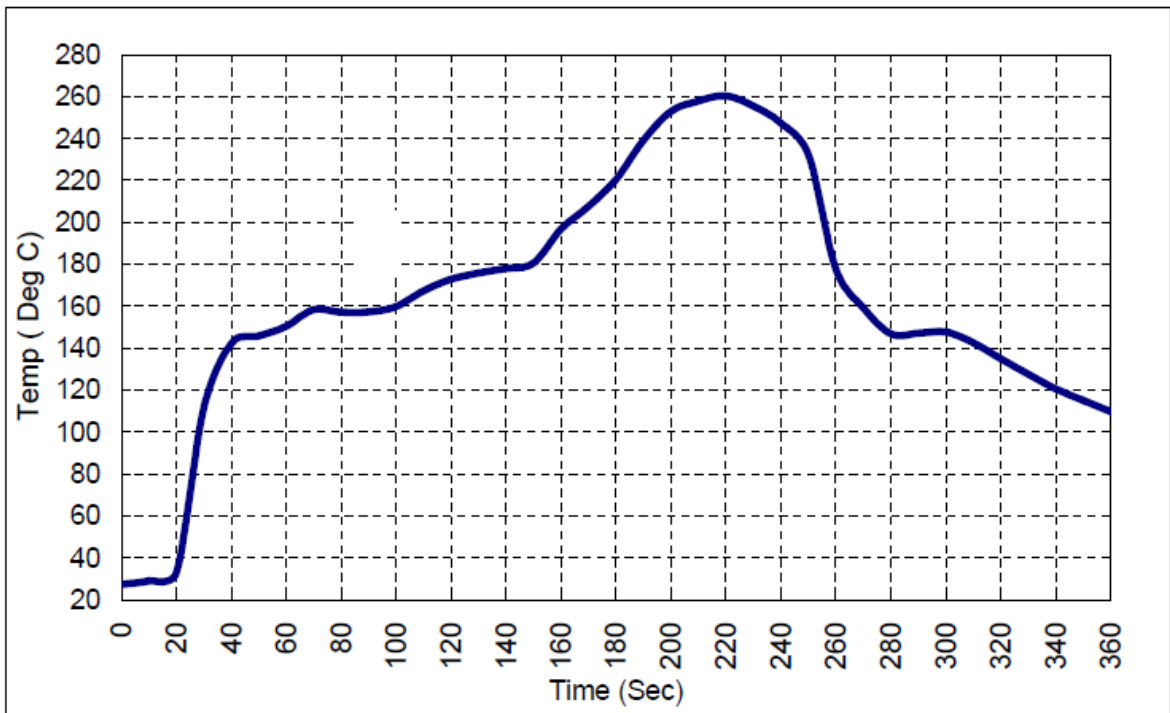

X-ON Electronics

Largest Supplier of Electrical and Electronic Components

Click to view similar products for [Signal Conditioning](#) category:

Click to view products by [Tai-Saw Technology](#) manufacturer:

Other Similar products are found below :

[MAPDCC0001](#) [MAPDCC0004](#) [PD0409J5050S2HF](#) [HHS-109-PIN](#) [AFS14A30-2185.00-T3](#) [AFS14A35-1591.50-T3](#) [DS-323-PIN](#) [DSS-313-PIN](#) [B39321R801H210](#) [1A0220-3](#) [JP510S](#) [LFB212G45SG8C341](#) [LFB322G45SN1A504](#) [LFL182G45TC3B746](#) [SF2159E](#) [30057](#)
[AFS1575.42S4-T](#) [FM-104-PIN](#) [CER0813B](#) [MAPDCC0005](#) [3A325](#) [40287](#) [41180](#) [ATB3225-75032NCT](#) [BD0810N50100AHF](#) [JHS-115-PIN](#)
[DC0710J5005AHF](#) [DC2327J5005AHF](#) [43020](#) [LFB2H2G60BB1C106](#) [LFL15869MTC1B787](#) [X3C19F1-20S](#) [XC3500P-20S](#) [10013-20](#)
[SF2194E](#) [CDBLB455KCAX39-B0](#) [TGL2208-SM, EVAL](#) [RF1353C](#) [051157-0000](#) [PD0922J5050D2HF](#) [1E1305-3](#) [1F1304-3S](#) [1G1304-30](#)
[B0922J7575AHF](#) [10017-3](#) [TP-103-PIN](#) [BD1222J50200AHF](#) [BD1722J50100AHF](#) [2450DP39K5400E](#) [BD0810J50150AHF](#)