



TAI-SAW TECHNOLOGY CO., LTD.

No. 3, Industrial 2nd Rd., Ping-Chen Industrial District,
Taoyuan, 324, Taiwan, R.O.C.

TEL: 886-3-4690038 FAX: 886-3-4697532

E-mail: tstsales@mail.taisaw.com Web: www.taisaw.com

Product Specifications Approval Sheet

Product Description: SAW DPX 836.5 / 881.5 MHz Band 5,Rx Balanced SMD 1.8X1.4 mm
(BW=25 MHz)

TST Part No.: TF0129D

Customer Part No.: _____

Customer signature required
Company: _____
Division: _____
Approved by : _____
Date: _____

Checked by: _____ Anne Chen 

Approved by: _____ Bob Chau 

Date: _____ 05, 11, 2017

1. Customer signed back is required before TST can proceed with sample build and receive orders.
2. Orders received without customer signed back will be regarded as agreement on the specifications.
3. Any specifications changes must be approved upon by both parties and a new revision of specifications shall be released to reflect the change



TAI-SAW TECHNOLOGY CO., LTD.

No. 3, Industrial 2nd Rd., Ping-Chen Industrial District,
Taoyuan, 324, Taiwan, R.O.C.

TEL: 886-3-4690038 FAX: 886-3-4697532

E-mail: tstsales@mail.taisaw.com Web: www.taisaw.com

SAW DPX 836.5/881.5 MHz Band 5 SMD 1.8X1.4 mm (BW=25 MHz)

MODEL NO.:TF0129D

REV.1.0

A. MAXIMUM RATING:

1. Operating temperature range: -20 °C to +85 °C
2. Storage temperature range: -40 °C to +85 °C
3. Tx Input power : 29dBm (Ta=+50°C,50000h,CW)
- 3.1Rx Input power : 15dBm
4. Maximum DC Voltage: 0 V
5. Moisture Sensitivity Level: Level 3 (MSL 3)
6. ESD 100V(MM) 200V(HBM)

RoHS Compliant
Lead free
Lead-free soldering

Electrostatic Sensitive Device (ESD)

B. ELECTRICAL CHARACTERISTICS:

Terminating impedance (Tx Port): 50 Ω(unbalanced)

Terminating impedance (Rx Port): 100 Ω//56nH (balanced)

Terminating impedance (Ant Port): 50 Ω//9.1nH (unbalanced)

Tx to ANT (f_{T0}=836.5 MHz)

Parameters Description		Unit	Min	Typ	Max	Remarks
Insertion Loss	824 ~ 849 MHz	dB	-	1.5	2.0	
Amplitude ripple	824 ~ 849 MHz	dB	-	0.6	1.2	
VSWR	ANT		-	1.6	2.0	
	Tx		-	1.5	2.0	
Attenuation:						
779.0 ~ 804.0 MHz		dB	35	41	-	
869.0 ~ 894.0 MHz		dB	40	45	-	
1565.42 ~ 1605.89 MHz		dB	35	44	-	
1648.0 ~ 1698.0 MHz		dB	35	44	-	
1710.0 ~ 1785.0 MHz		dB	35	42		
1805.0 ~ 1880.0 MHz		dB	33	40	-	
1920.0 ~ 1980.0 MHz		dB	30	38	-	
2110.0 ~ 2170.0 MHz		dB	30	35	-	
2400.0 ~ 2557.0 MHz		dB	25	31	-	
4900.0 ~ 5950.0 MHz		dB	20	33		

ANT to Rx (f_{T0}=881.5 MHz)

Parameters Description		Unit	Min	Typ	Max	Remarks
Insertion Loss	869 ~ 894 MHz	dB	-	1.8	2.3	
Amplitude ripple	869 ~ 894 MHz	dB	-	0.4	1.2	
Phase Balance	869 ~ 894 MHz	deg	-10	+0.1/+2.5	+10	
Amplitude Balance	869 ~ 894 MHz	dB	-1.0	-0.1/+0.4	+1.0	
VSWR	ANT	-		1.7	2.0	
	Rx	-		1.7	2.0	
Attenuation:						
824.0 ~ 849.0		dB	48	52		
1710.0 ~ 1788.0		dB	45	51		
1850.0 ~ 1920.0		dB	45	50		
1920.0 ~ 1980.0		dB	45	50		
2400.0 ~ 2500.0		dB	44	49		
3476.0 ~ 3576.0		dB	40	46		
4900.0 ~ 5950.0		dB	30	40		

Tx to Rx

Isolation	824 ~ 849 MHz	dB	53	56	-	
	869 ~ 894 MHz	dB	45	48	-	

Notes : (1) With Matching Network

C. FREQUENCY CHARACTERISTICS:

Tx to Ant

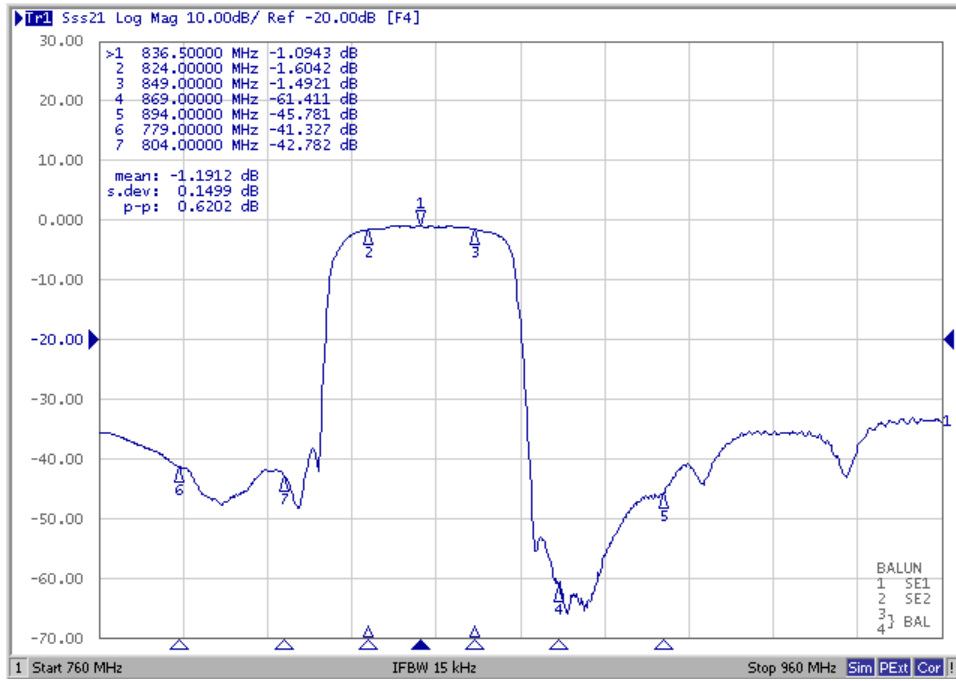

Ant to Rx

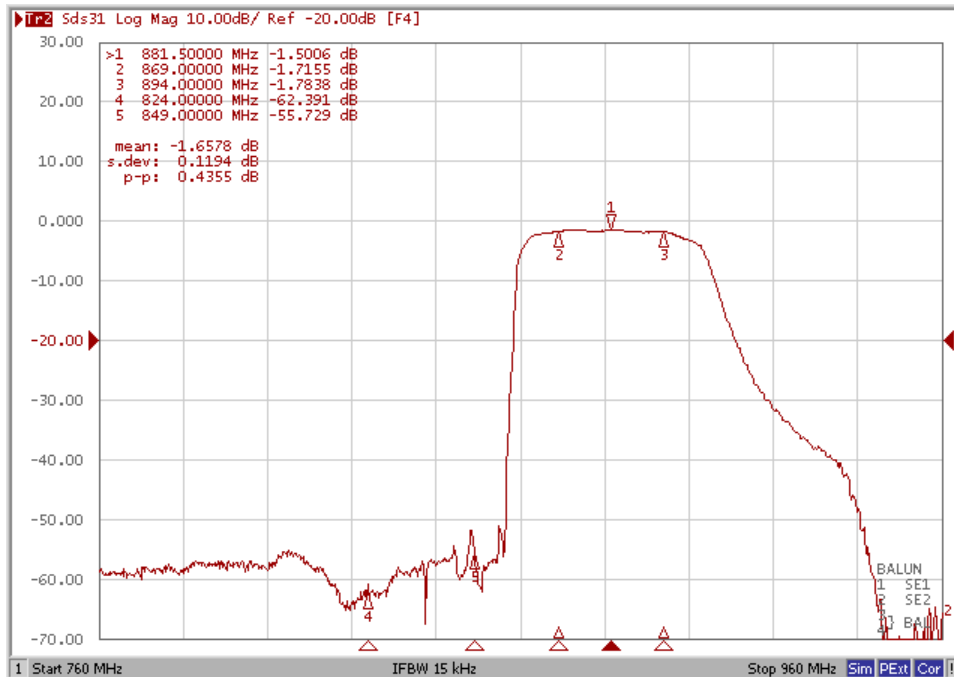

Ripple

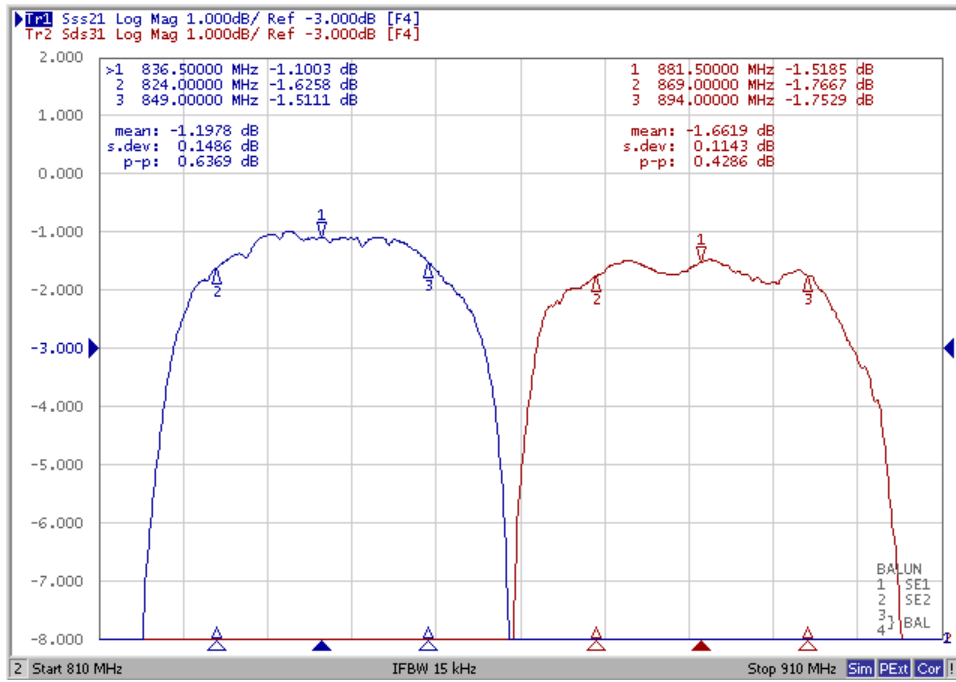

Isolation

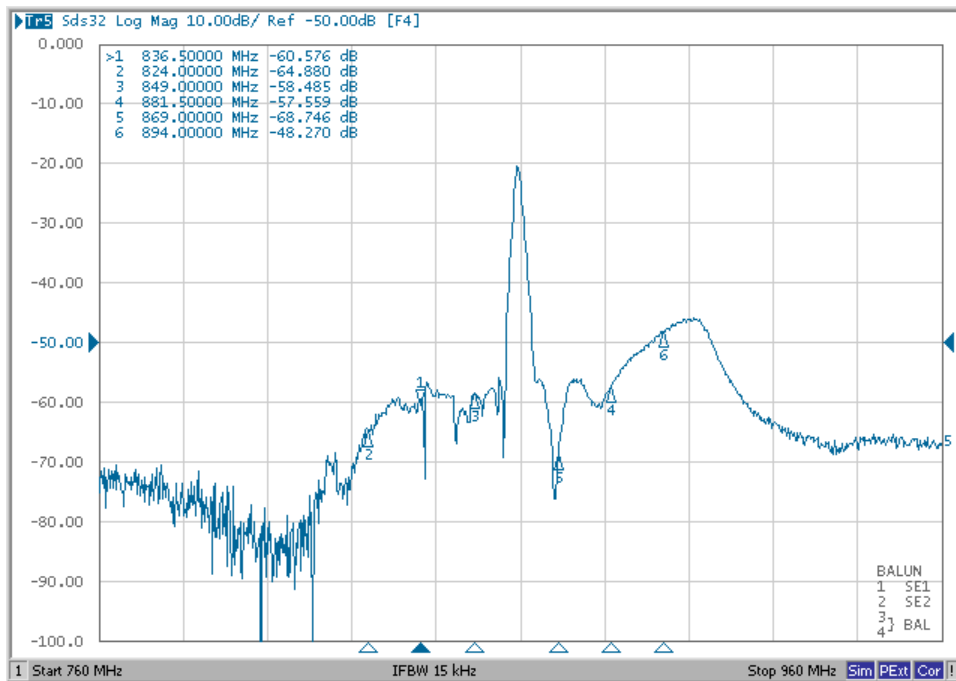

VSWR (Tx Port)

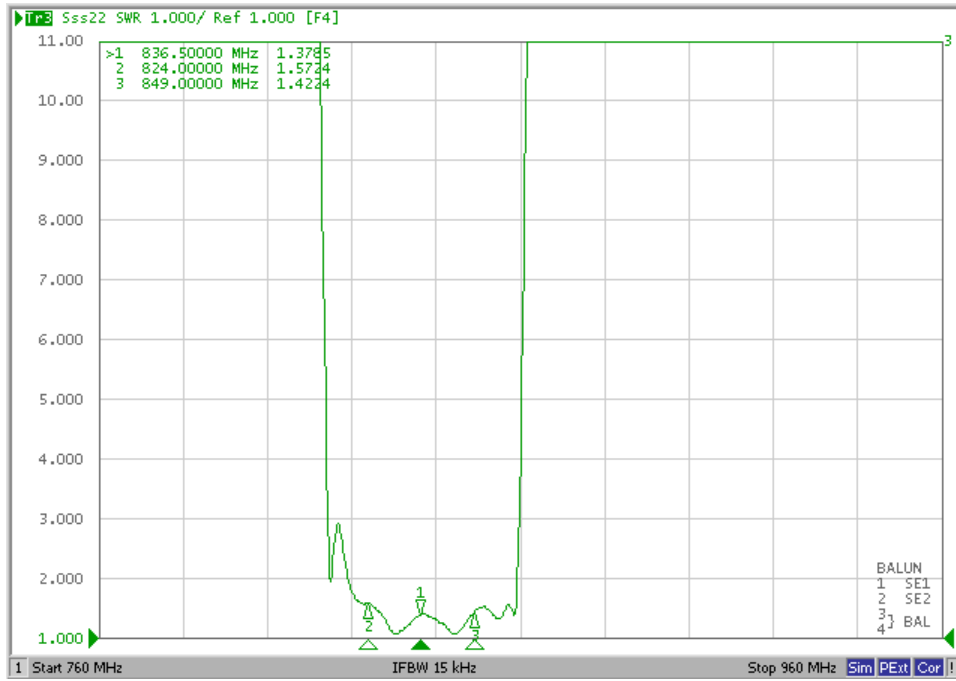

Smith Chart (Tx Port)

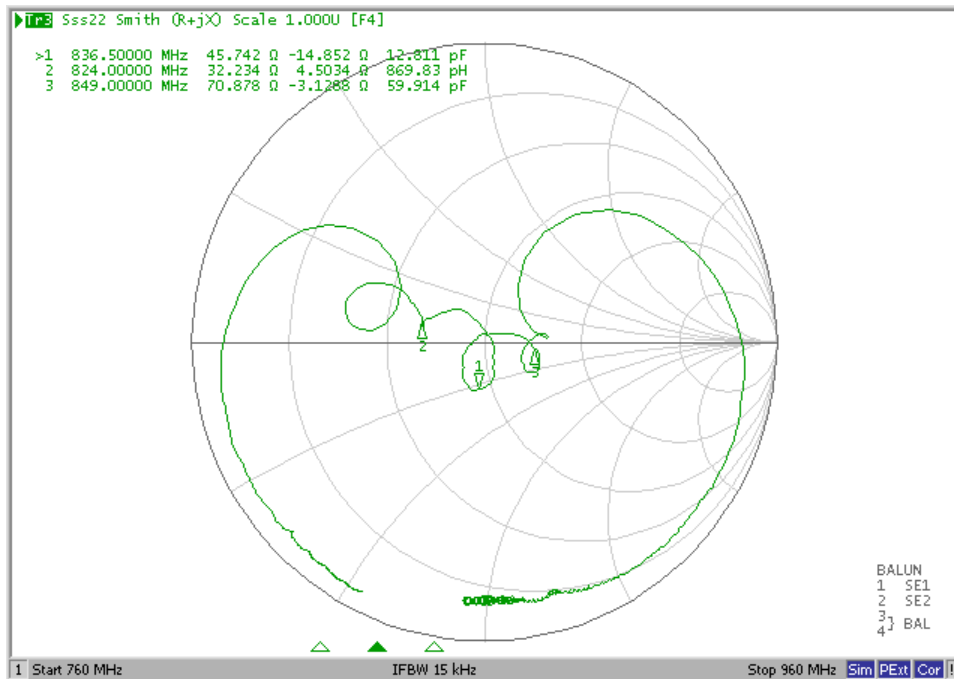

VSWR (Rx Port)

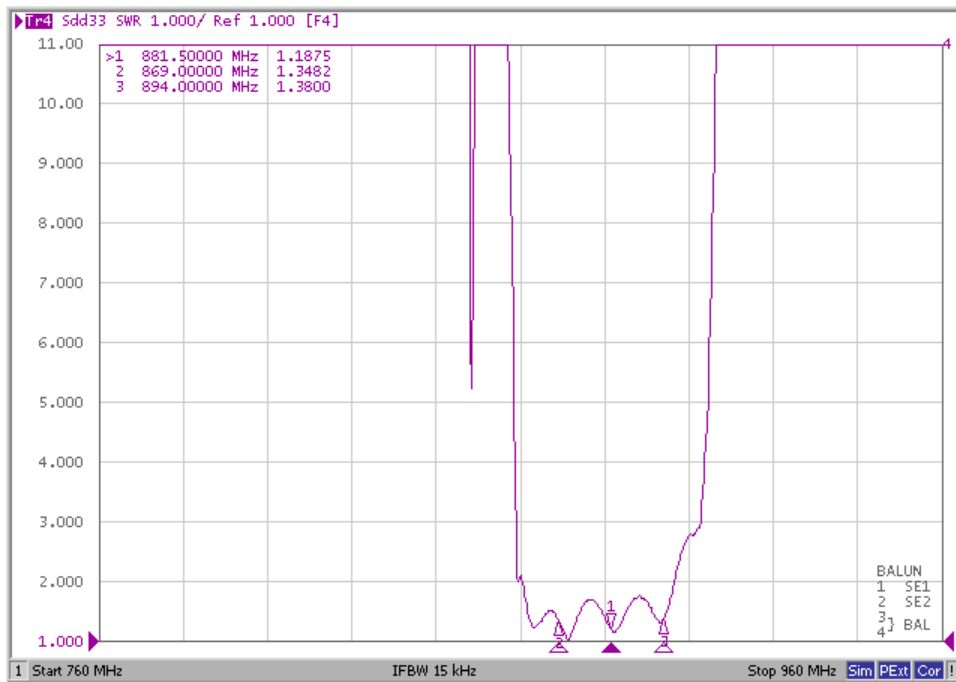

Smith Chart (Rx Port)

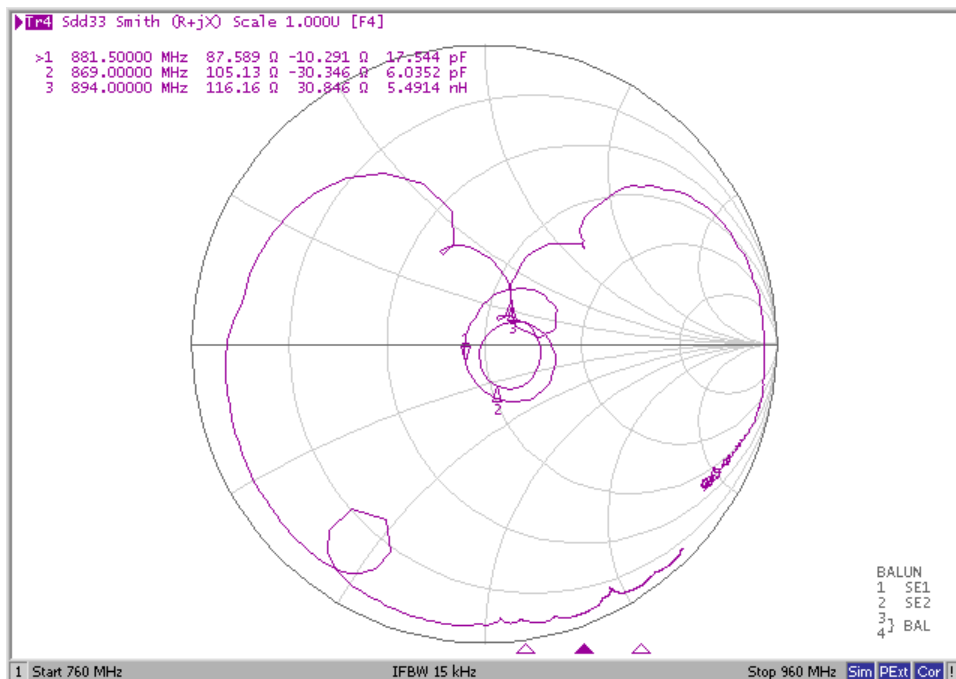

VSWR (ANT Port)

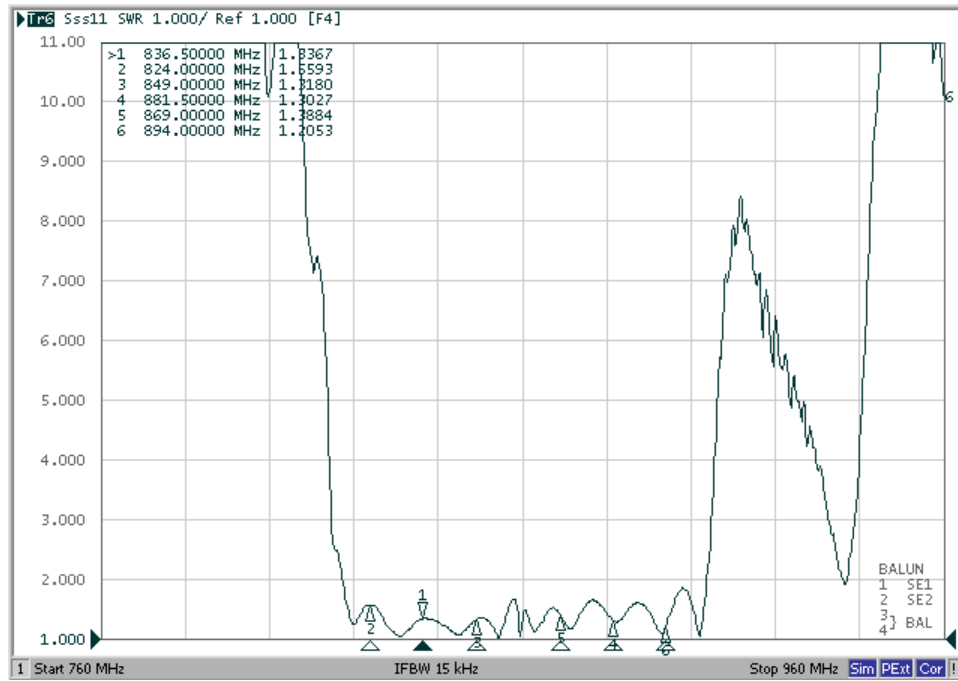

Smith Chart (ANT Port)

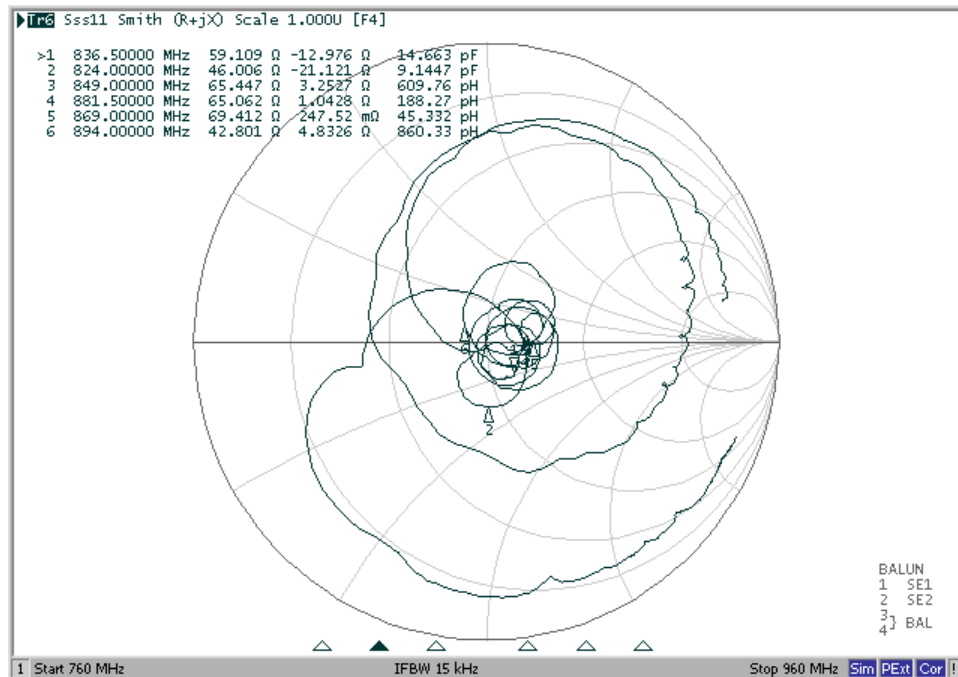

Phase Balance

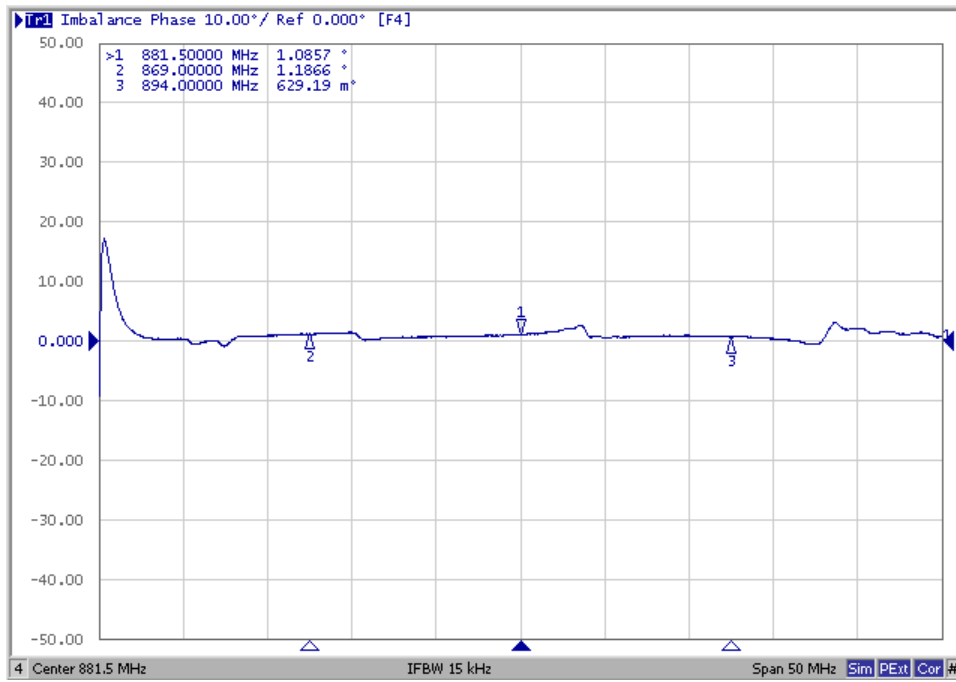

Amplitude Balance

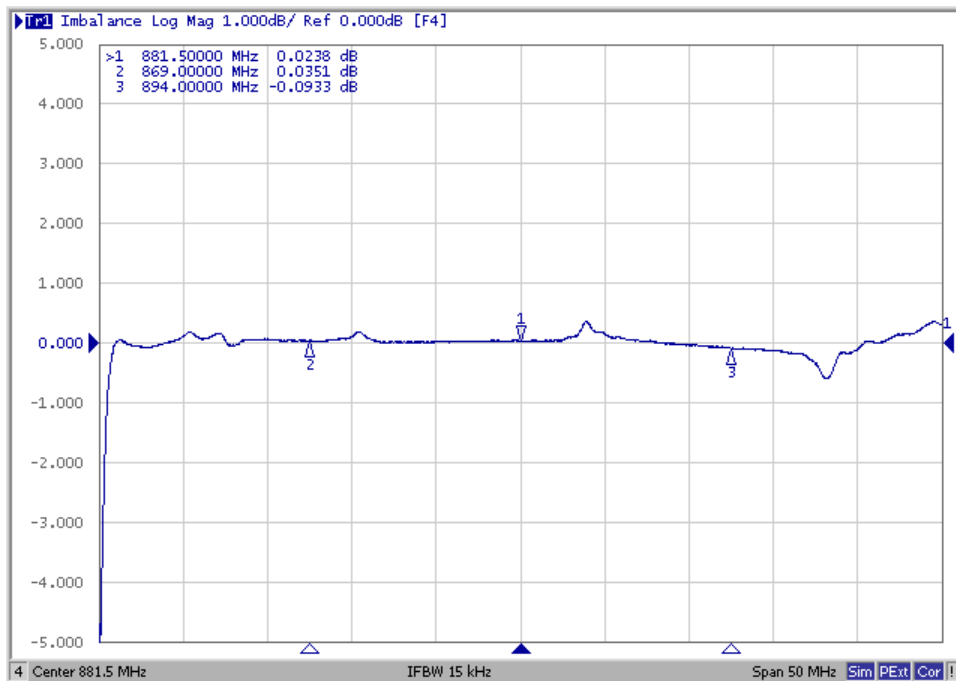

Wide Span

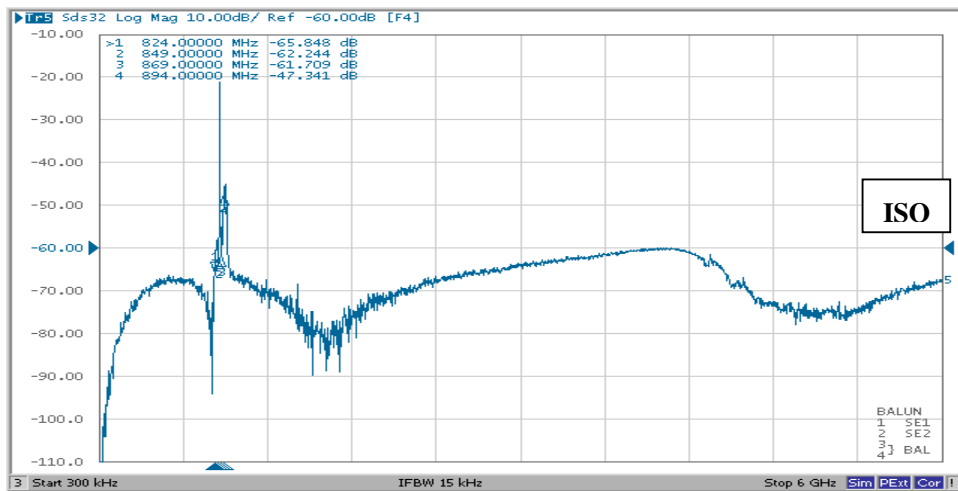
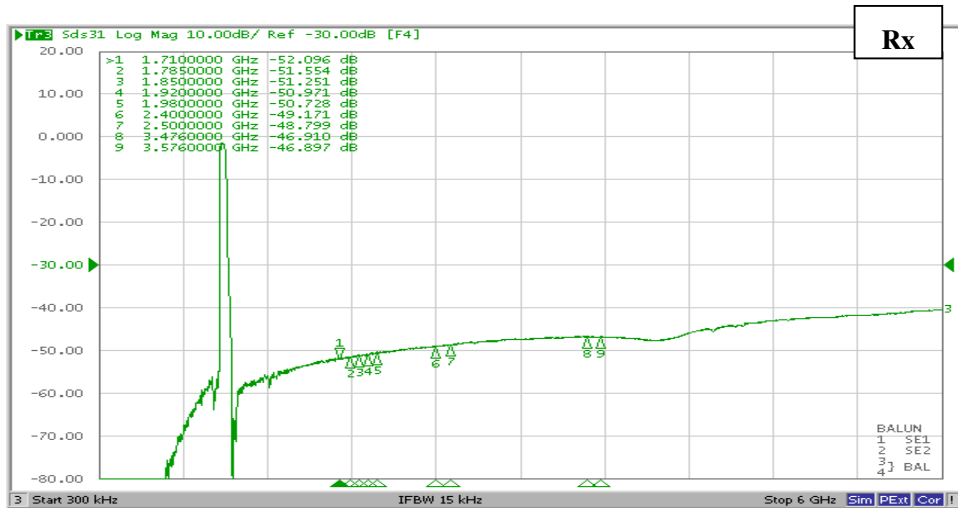
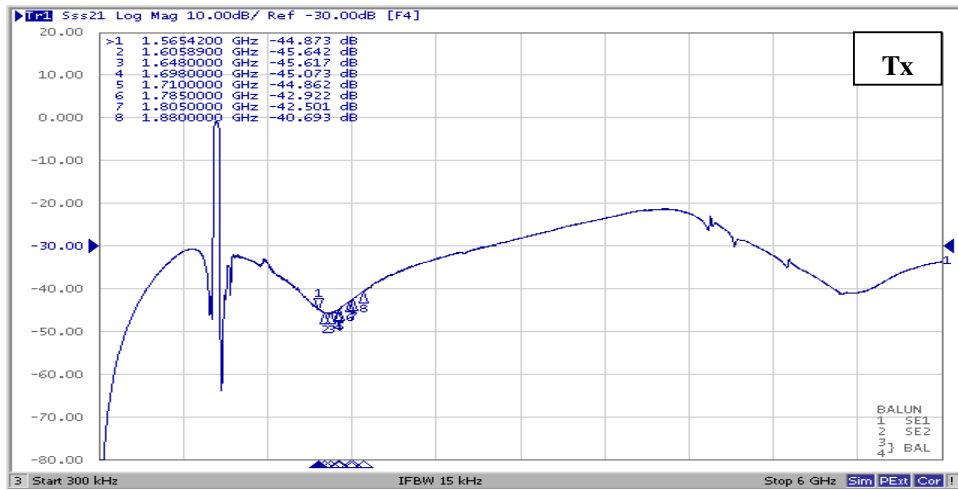

D.OUTLINE DRAWIN:

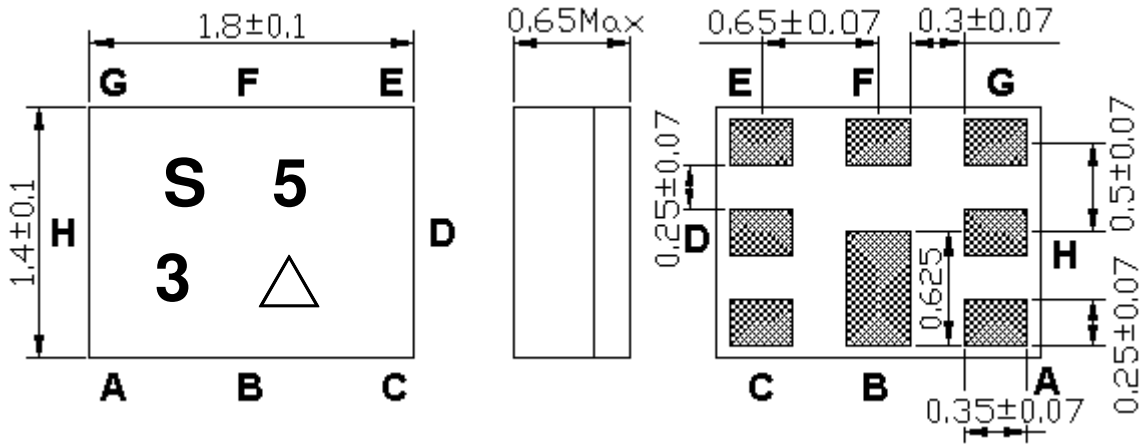

Marking Descriptions	
S	Marking name
5	Band Class
3	Series Number
△	Date Code(Year+Month)

Pin Description	
B,D,E,G	Ground
F	Ant
C	Tx (836.5MHz)
A,H	Rx (881.5MHz)

Date Code (year+month)

Year	Jan.	Feb.	Mar.	Apr.	May.	Jun.	Jul.	Aug.	Sep.	Oct.	Nov.	Dec.
2013	A	B	C	D	E	F	G	H	J	K	L	M
2014	N	P	Q	R	S	T	U	V	W	X	Y	Z
2015	a	b	c	d	e	f	g	h	j	k	l	m
2016	n	p	q	r	s	t	u	v	w	x	y	z
2017	<u>A</u>	<u>B</u>	<u>C</u>	<u>D</u>	<u>E</u>	<u>F</u>	<u>G</u>	<u>H</u>	<u>J</u>	<u>K</u>	<u>L</u>	<u>M</u>
2018	<u>N</u>	<u>P</u>	<u>Q</u>	<u>R</u>	<u>S</u>	<u>T</u>	<u>U</u>	<u>V</u>	<u>W</u>	<u>X</u>	<u>Y</u>	<u>Z</u>
2019	<u>a</u>	<u>b</u>	<u>c</u>	<u>d</u>	<u>e</u>	<u>f</u>	<u>g</u>	<u>h</u>	<u>i</u>	<u>k</u>	<u>l</u>	<u>m</u>
2020	<u>n</u>	<u>p</u>	<u>q</u>	<u>r</u>	<u>s</u>	<u>t</u>	<u>u</u>	<u>v</u>	<u>w</u>	<u>x</u>	<u>y</u>	<u>z</u>

E. Evaluation Circuit

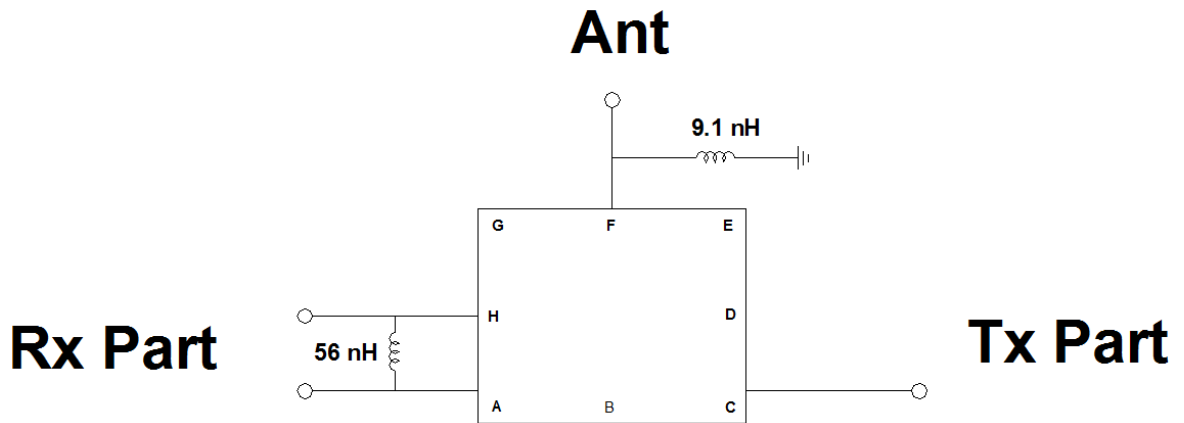

F. FOOTPRINT:

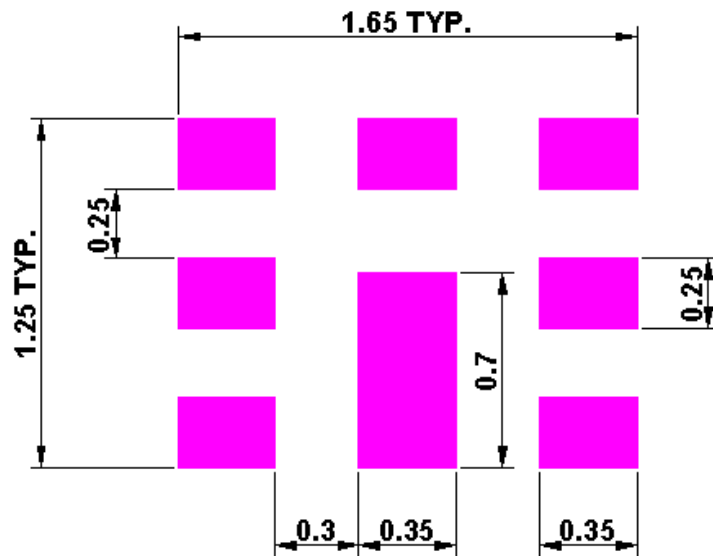

G. PACKING:

1. REEL DIMENSION

(Please refer to FR-75D10 for packing quantity)

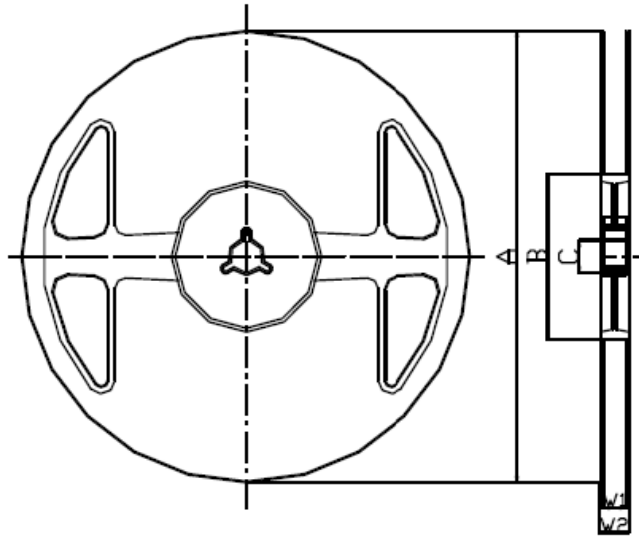

Materials of Reel

Material : Polystyrene + Carbon
 Characteristics : Conforms to EIAJ-ET-7200A
 Color : Black
 Surface resistance (reference value) : $10^9\Omega/\text{sq Max.}$

Unit : mm

Code	Quantity	A	B	C	W1	W2
Z	3,000 pcs	$\phi 180.0 +0.0/-1.5$	$\phi 66.0 +/-0.5$	$\phi 13.0 +/-0.2$	$9.0 +1.0/-0.0$	$11.4 +/-1.0$

2. TAPE DIMENSION

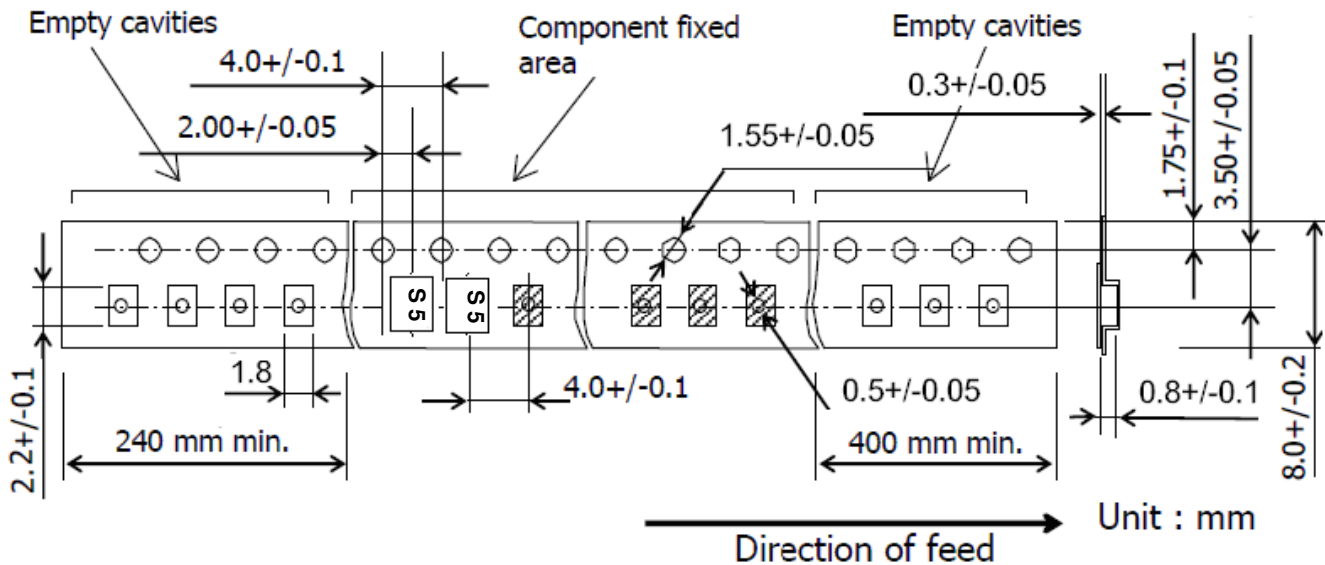

H. RECOMMENDED REFLOW PROFILE :

1. Preheating shall be fixed at 150~180°C for 60~90 seconds.
2. Ascending time to preheating temperature 150°C shall be 30 seconds min.
3. Heating shall be fixed at 220°C for 50~80 seconds and at 245~260°C peak (min. 10sec).
4. Time : 2 times.

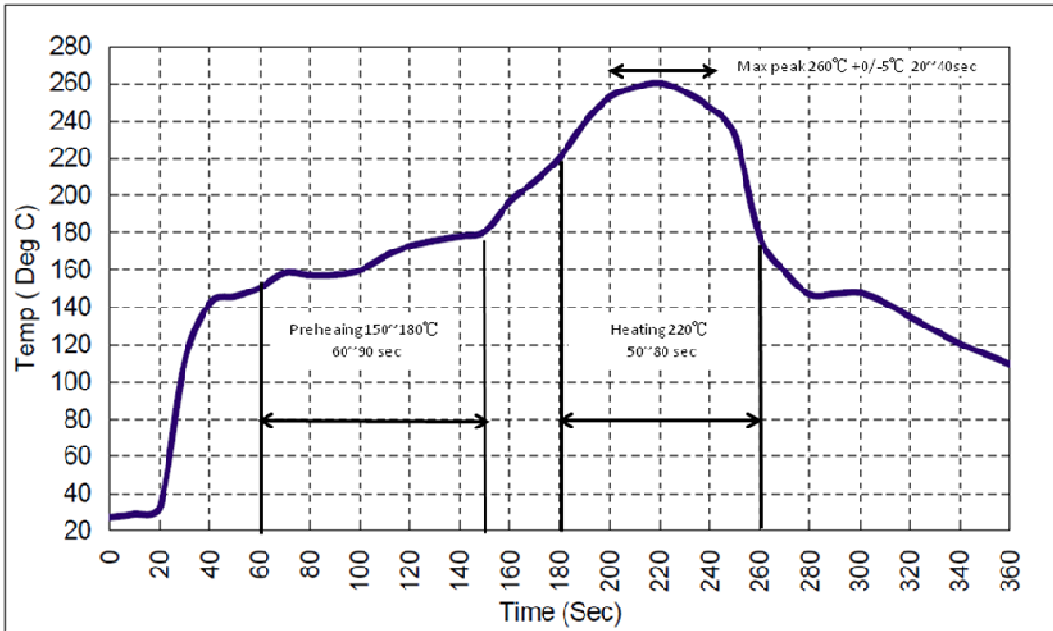

X-ON Electronics

Largest Supplier of Electrical and Electronic Components

Click to view similar products for [Signal Conditioning](#) category:

Click to view products by [Tai-Saw Technology](#) manufacturer:

Other Similar products are found below :

[PD0409J5050S2HF](#) [HHS-109-PIN](#) [AFS14A35-1591.50-T3](#) [JP510S](#) [LFB322G45SN1A504](#) [SF2159E](#) [FM-104-PIN](#) [CER0813B](#)

[MAPDCC0005](#) [3A325](#) [BD0810N50100AHF](#) [DC0710J5005AHF](#) [DC2327J5005AHF](#) [LFL15869MTC1B787](#) [X3C19F1-20S](#)

[CDBLB455KCAX39-B0](#) [RF1353C](#) [051157-0000](#) [PD0922J5050D2HF](#) [600S150FTRB](#) [1E1305-3](#) [1F1304-3S](#) [TP-103-PIN](#)

[BD1222J50200AHF](#) [BD1722J50100AHF](#) [2450DP39K5400E](#) [BD0810J50150AHF](#) [BD1722J50200AHF](#) [DS-327-PIN](#) [MACP-008125-](#)

[CK07F0](#) [DS-329-PIN](#) [DS-313-PIN](#) [TP-104-PIN](#) [TP-101-PIN](#) [HH-128-PIN](#) [8594810000](#) [T-1000-N](#) [JP506S](#) [XC0900P-10S](#) [XC0900B-30S](#)

[CHE1260-QAG](#) [11305-10](#) [5962-9091202MXA](#) [3A412S](#) [X3C06A4-03S](#) [B39000Z3410A4](#) [DSS-333-PIN](#) [PD2425J5050S2HF](#)

[B39242B4360P810](#) [B39781B8005P810](#)