



TAI-SAW TECHNOLOGY CO., LTD.

No. 3, Industrial 2nd Rd., Ping-Chen Industrial District,
Taoyuan, 324, Taiwan, R.O.C.

TEL: 886-3-4690038 FAX: 886-3-4697532

E-mail: tstsales@mail.taisaw.com Web: www.taisaw.com

Product Specifications Approval Sheet

Product Description: VCTCXO SMD 7.0x5.0 16.384MHz

TST Part No.: TX1066AA4315

Customer Part No.: _____

<p>Customer signature required</p> <p>Company: _____</p> <p>Division: _____</p> <p>Approved by : _____</p> <p>Date: _____</p>

Checked by: _____ Yifan Chen

Approved by: _____ Kelly Huang

Date: _____ 06/28/2023

1. Customer signed back is required before TST can proceed with sample build and receive orders.
2. Orders received without customer signed back will be regarded as agreement on the specifications.
3. Any specifications changes must be approved upon by both parties and a new revision of specifications shall be released to reflect the changes.



TAI-SAW TECHNOLOGY CO., LTD.
VCTCXO SMD 7.0x5.0 16.384MHz

MODEL NO.: TX1066AA4315

REV. NO.: 1.0

Revise:

Rev.	Rev. Page	Rev. Account	Date	Ref. No.	Reviser
1	N/A	Initial release	06/28/23'	N/A	Yifan Chen



TAI-SAW TECHNOLOGY CO., LTD.

No. 3, Industrial 2nd Rd., Ping-Chen Industrial District,
Taoyuan, 324, Taiwan, R.O.C.

TEL: 886-3-4690038 FAX: 886-3-4697532

E-mail: tstsales@mail.taisaw.com Web: www.taisaw.com

VCTCXO SMD 7.0x5.0 16.384MHz

MODEL NO.: TX1066AA4315

REV. NO.:1.0

Features:

- Ultra Miniature SMD Package
- Good Frequency Stability
- Good Phase Noise Response
- Moisture Sensitivity Level (MSL) : Level-1



Description and Applications:

Surface mount 7.0mmx5.0mm VCTCXO for use in wireless communications devices

➤ FREQUENCY CHARACTERISTICS

	Parameter	Min.	Typ.	Max.	Units	Test Condition
1-1	Nominal Frequency	16.384000			MHz	
1-2	Nominal Frequency Tolerance	-1.0		+1.0	ppm	Frequency at 25°C, before reflow.
1-3	Frequency stability over temperature	-1.0		+1.0	ppm	Referenced to the frequency at 25°C.
1-4	Operating Temperature range	-40		+85	°C	The operating temperature range over which the frequency stability is measured
1-5	Storage Temperature range	-40		+85	°C	
1-5	Supply voltage stability	-0.2		+0.2	ppm	Supply voltage varied ±5% at 25°C
1-6	Aging	-1		+1	ppm	Year at 25°C

➤ POWER SUPPLY

	Parameter	Min.	Typ.	Max.	Units	Test Condition
2-1	Supply voltage	2.97	3.3	3.63	V	
2-2	Current			6	mA	At maximum supply voltage

➤ **CONTROL VOLTAGE**

	Parameter	Min.	Typ.	Max.	Units	Test Condition
3-1	Control voltage range	0.5	1.5	2.5	V	
3-2	Pulling range	±5		±12	ppm	Referenced to VCON at 1.5V
3-3	Vcon input impedance				kOhm	Measured between VCON and GND pin
3-4	Linearity			10	%	

➤ **OSCILLATOR OUTPUT**

	Parameter	Min.	Typ.	Max.	Units	Test Condition
4-1	Output waveform	CMOS				
4-2	Output voltage level high	2.97			V	
4-3	Output voltage level low			0.33	V	
4-4	Output load capacitance			15	pF	Operating range
4-5	Duty cycle	45	50	55	%	Measured at 50% VDD trigger level
4-6	Rise and fall times			6	ns	CMOS logic output at 10% to 90%
4-7	Start time			10	ms	

Mechanical Dimensions (mm):

[TOP VIEW]

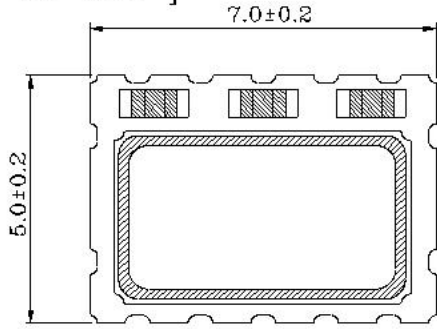

[BOTTOM VIEW]

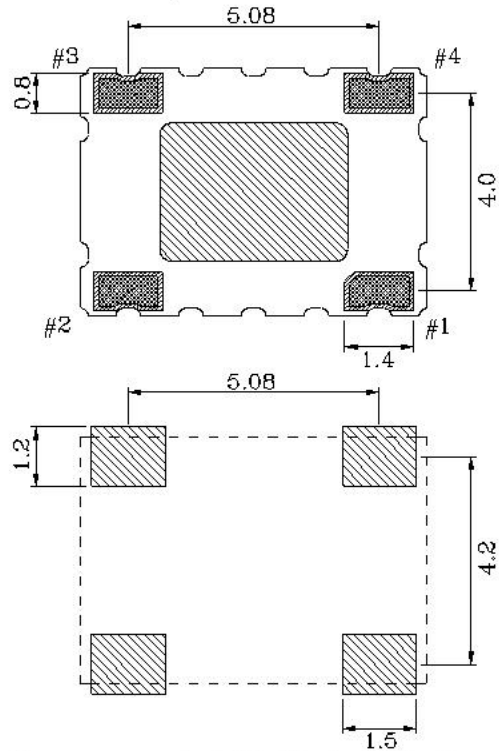

[SIDE VIEW]

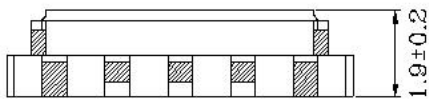

PIN FUNCTIONS

Pin	Function
#1	VOCN:VC-TCXO NC:TCXO
#4	GND
#5	Fout
#8	VDD

Recommended Soldering Pattern

Test Circuit:

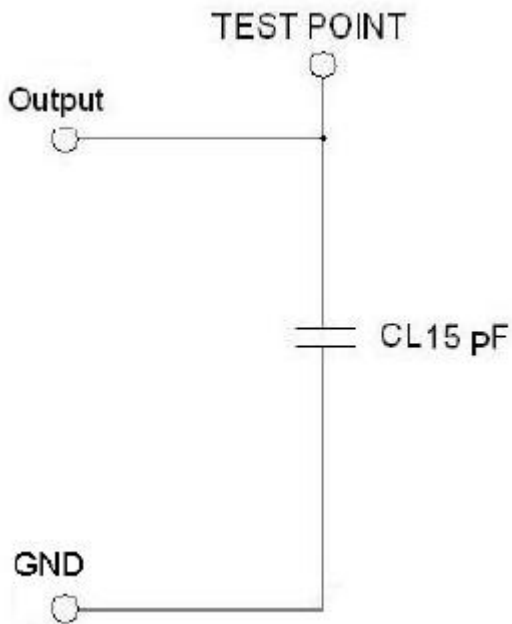

Output Waveform :

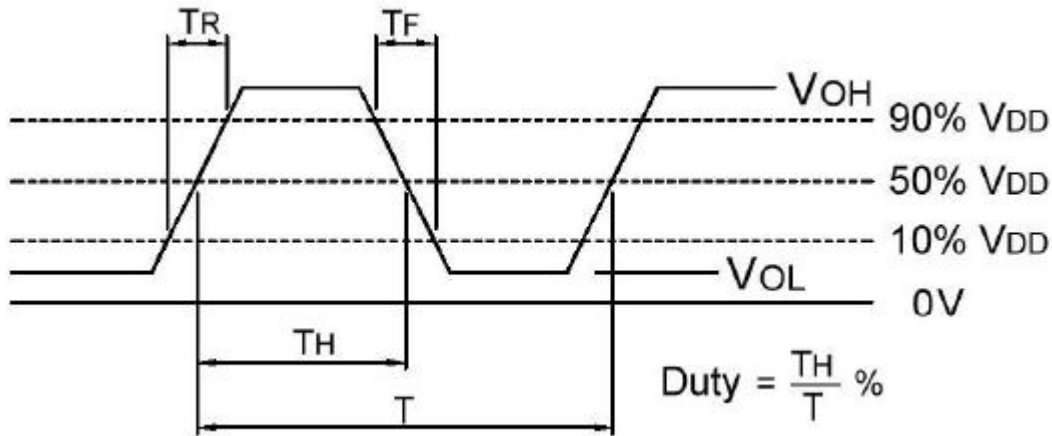

Marking:

Line 1 : Frequency (16.384)

Line 2: TST Logo + Product Code + Date Code + Internal Traceability Code (XX) : Can be 1 or 2 letters)

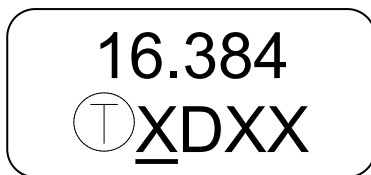

Product Code Table

Year	2021	2022	2023	2024
	2025	2026	2027	2028
	2029	2030	2031	2032
Product code	X	x	<u>X</u>	<u>x</u>

Date Code Table

WK01	WK02	WK03	WK04	WK05	WK06	WK07	WK08	WK09	WK10	WK11	WK12	WK13
A	B	C	D	E	F	G	H	I	J	K	L	M
WK14	WK15	WK16	WK17	WK18	WK19	WK20	WK21	WK22	WK23	WK24	WK25	WK26
N	O	P	Q	R	S	T	U	V	W	X	Y	Z
WK27	WK28	WK29	WK30	WK31	WK32	WK33	WK34	WK35	WK36	WK37	WK38	WK39
a	b	c	d	e	f	g	h	i	j	k	l	m
WK40	WK41	WK42	WK43	WK44	WK45	WK46	WK47	WK48	WK49	WK50	WK51	WK52
n	o	p	q	r	s	t	u	v	w	x	y	z

Reel Dimensions (mm):

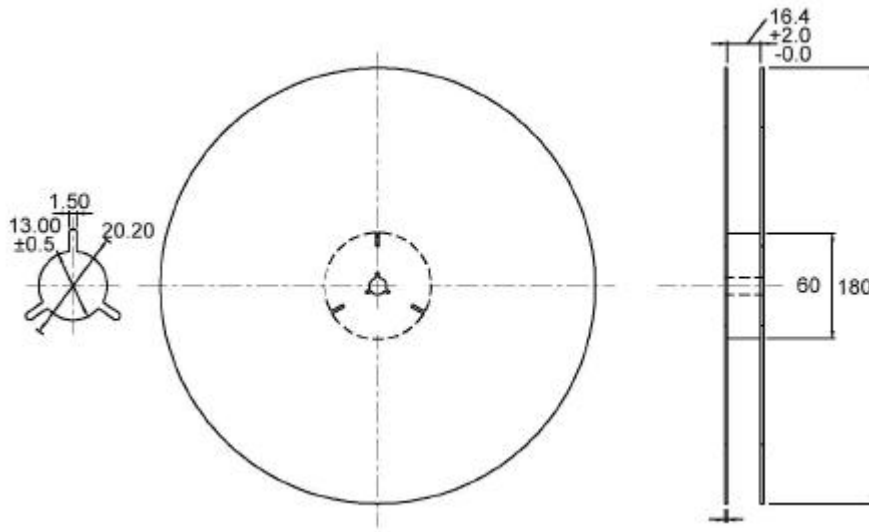

Tape Dimensions (mm):

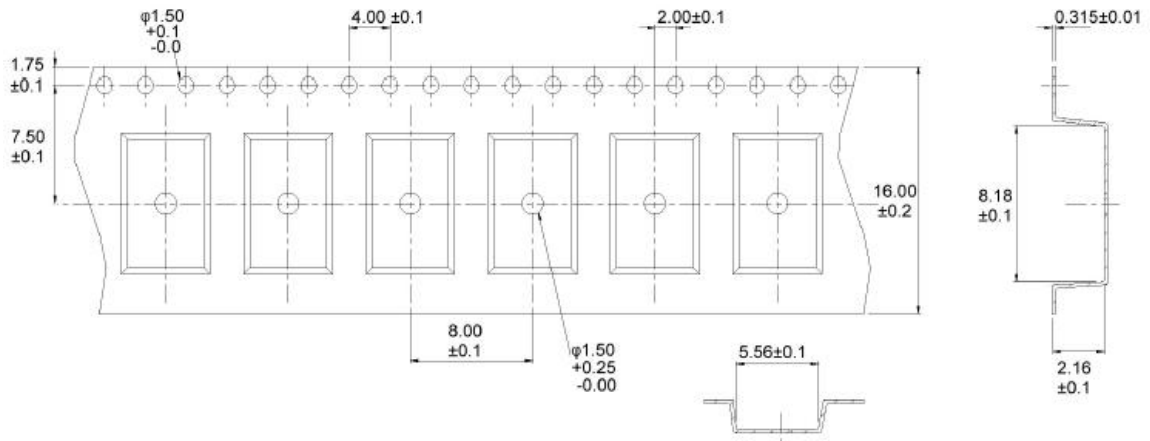

THE DIRECTION OF PACKING

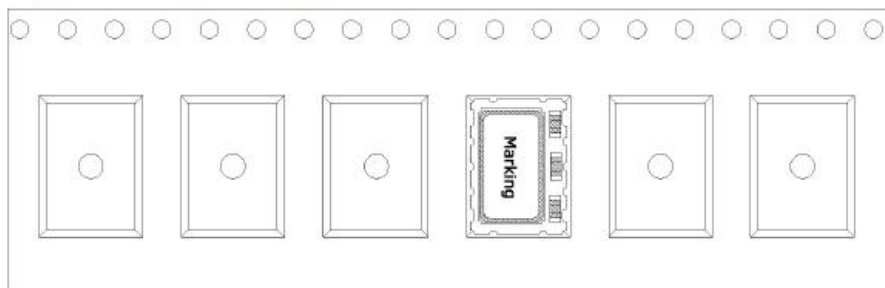

Packing Quantity/Packing:

1K pcs maximum per reel

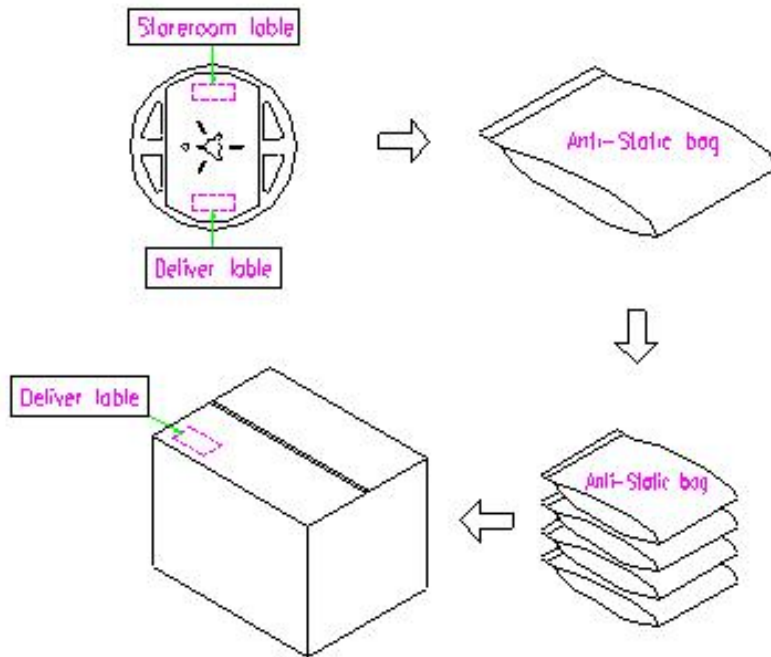

Reflow Profile:

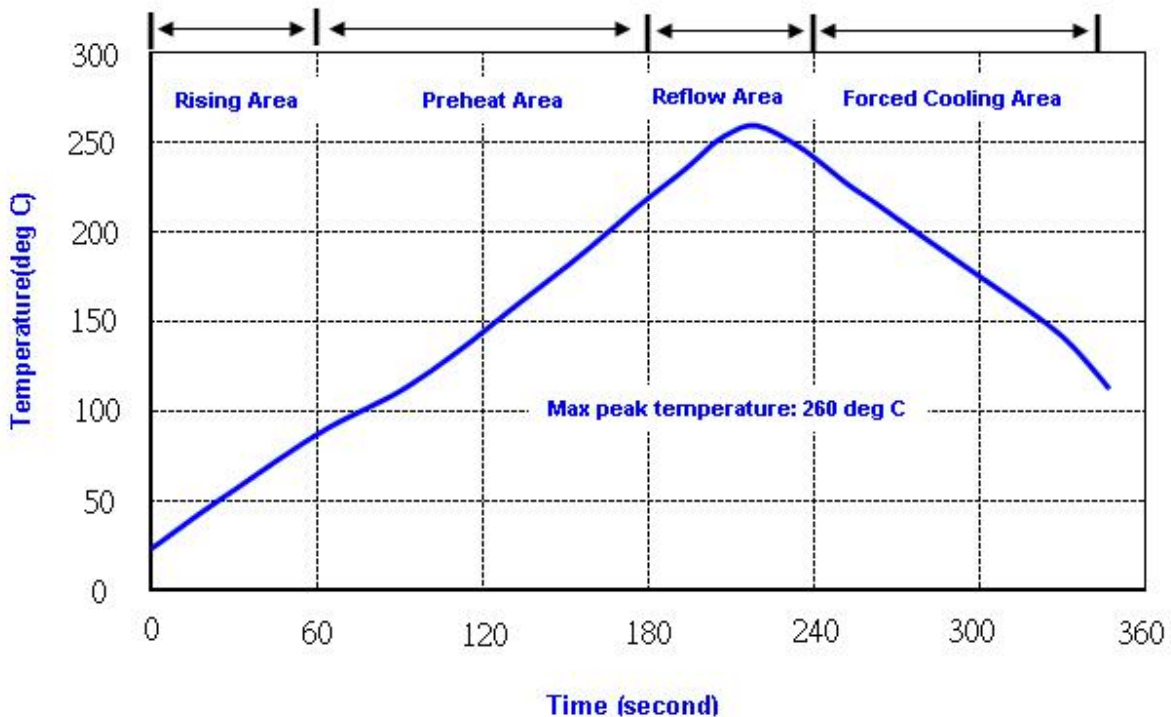

- Note: 1. Max peak temperature: 260+/-5 deg C; Time: 10+/-2 sec
- 2. Temperature: 217+/-5 deg C; Time: 90~100 sec

Notes of the Usage:

1. Touch the solder iron at 260 ± 5 deg C onto the leads for 10 ± 2 sec max or touch the solder at 350 ± 5 deg C onto the leads for 3 ± 0.5 sec.
2. In the customer's reflow process, if it will remain some mechanical stress at the soldering terminals, also make some cracks on the soldering termination. Some cracks will cause open or short circuit and cause of thermal increasing or smoking. Don't make any excess mechanical stress to soldering points.
3. In case of giving a heavy shock to the products, it may make an open or short circuit and cause of thermal increasing and smoking. To avoid heavy shock impact applying to products is strictly required.
4. Ultrasonic cleaning should be avoided to prevent damage to the TCXO.
5. Do Not Use Ultrasonic-Wave Soldering or Wave Solder with Package Immersed in Solder.

Notes of the Storage:

1. To keep products under the condition at the room temperature ($-5\sim 35$ deg C) with normal humidity (45~75%). Absorption of moisture and dewdrop may make inferiority of characteristics and a short circuit.
2. Oxidization of terminals shall make the solderability more inferior. Dusts and corrosive gas will make a cause of the open or short circuit. Keep it in the clean place where is not in dusty and no corrosive gas.
3. Use the anti-static material to the storage package.
4. Don't put any excess weight to the VCTCXO in the storage process.
5. Don't move the product from the cold place to the hot place in the short time, otherwise it may make some dew-drop, then a short circuit may happen in case.
6. Storage periods should be maximum 6 months under condition of above item 1 after delivery from TST factory.
7. Once open the bag, there is possibility of electrical characteristics deterioration due to absorption of moisture. So, please use parts within 7 days after opening the bag.
8. If you have to keep parts without using after opening the bag, please put the drying agent in the bag, fold the bag and keep it in the place where temperature and humidity are controlled (nitrogen atmosphere box etc.)

Reliability Specifications

Test name	Test process / method	Reference standard
Mechanical characteristics		
resistance to Soldering heat (IR reflow)	Temp./ Duration : 265°C /10sec ×2 times Total time : 4min.(IR-reflow)	EIAJED-4701 -300(301)M(II)
Vibration	Total peak amplitude : 1.5mm Vibration frequency : 10 to 2000 Hz Sweep period : 20 minute Vibration directions : 3 mutually perpendicular Duration : 2 hr / direc.	MIL-STD 202G method 204
Mechanical Shock	directions : 3 impacts per axis Acceleration : 3000g's, +20/-0 % Duration : 0.3 ms (total 18 shocks) Waveform : Half-sine	MIL-STD 202G method 213
Solderability	Solder Temperature:265±5°C Duration time: 5±0.5 seconds.	J-STD-002
Environmental characteristics		
Thermal Shock	Heat cycle conditions -40 °C (30min) ↔ 85 °C (30min) * cycle time : 10 times	MIL-STD 883G method 1010.8
Humidity test	Temperature : 85 ± 2 °C Relative humidity : 85% Duration : 96 hours	MIL-STD 202G method 103
Dry heat (Aging test)	Temperature : 125 ± 2 °C Duration : 168 hours	MIL-STD 202G method 108A
Cold resistance (Low Temp Storage)	Temperature : -40 ± 2 °C Duration : 96 hours	IEC 60068-2-1

X-ON Electronics

Largest Supplier of Electrical and Electronic Components

Click to view similar products for [TCXO Oscillators](#) category:

Click to view products by [Tai-Saw Technology](#) manufacturer:

Other Similar products are found below :

[AST3TQ-40.000MHZ-5](#) [SIT5000ACC8E-33VQ-19.200000X](#) [SiT5001AI-2E-33N0-48.000000X](#) [TG3225CEN 25.0000M-KFGNNAB](#)
[SIT5001AI-2E-33N0-24.000000x](#) [SIT1566AC-JV-18E-32.768E](#) [AST3TDATACJ5-10.0000MHz](#) [AST3TDATACJ5-20.0000MHz](#)
[AST3TDA53TACJ2-38.8800MHz](#) [AST3TDATACJ5-38.8800MHz](#) [NT0503CC3I287EN10](#) [NT0503CH3I287CN25](#) [NT0503CH3I287CN30.72](#)
[NT0503CC3I287DN20](#) [TG-3541CE 32.7680KXB0](#) [KT1612A26000AAW18TBL](#) [KT1612A26000AAW18NBL](#) [TG-5006CG-12H 26.0000M0](#)
[TG2520SMN 38.4000M-MCGNNM3](#) [TG-5006CG-28L 52.0000MX](#) [X1G004131000900](#) [X1G0041310042](#) [1XXC26000PKA](#)
[X1G005441030316](#) [X1G005441020616](#) [X1G005441030416](#) [X1G005421020416](#) [X1G005441020316](#) [7L26002007](#) [1XTV12800MDA](#)
[X1G005421031215](#) [X1G005421020516](#) [SX1T19.200B010J020S](#) [T132S4-25000ML33DTL](#) [X1G0053710200](#) [NT0503CH3I287EN10](#) [8153H-](#)
[50.000LH33DTL](#) [NT0503EH3I106EN10](#) [NT0507BH3I107BN40](#) [NT0503CH3I207EN10](#) [NT0507BH3I507EA10](#) [BT0507BC3I287CN38.4B](#)
[NT0507BH3I106BA50](#) [NT0503CH3I507CN24.576](#) [OW2EL89CENUXFMYLC-16M](#) [OW2EL89CENUXFMYLC-32M](#)
[OW2EL89CENUXFMYLC-24M](#) [OW7EL89CENUYO3YLC-24M](#) [OW3EL89CENUNFAYLC-26M](#) [OW7EL89CENUYO3YLC-20M](#)