



# TAI-SAW TECHNOLOGY CO., LTD.

No. 3, Industrial 2nd Rd., Ping-Chen Industrial District,  
Taoyuan, 324, Taiwan, R.O.C.

TEL: 886-3-4690038 FAX: 886-3-4697532

E-mail: [tstsales@mail.taisaw.com](mailto:tstsales@mail.taisaw.com) Web: [www.taisaw.com](http://www.taisaw.com)

## Product Specifications Approval Sheet

Product Description: Crystal Unit SMD 3.2x2.5 20.0MHZ

TST Part No.: TZ1565B

Customer Part No.: \_\_\_\_\_

Customer signature required
Company: _____
Division: _____
Approved by : _____
Date: _____

Checked by: \_\_\_\_\_ Ann Liu 

Approved by: \_\_\_\_\_ Kelly Huang 

Date: \_\_\_\_\_ 10/21/2010

1. Customer signed back is required before TST can proceed with sample build and receive orders.
2. Orders received without customer signed back will be regarded as agreement on the specifications.
3. Any specifications changes must be approved upon by both parties and a new revision of specifications shall be released to reflect the changes.



**TAI-SAW TECHNOLOGY CO., LTD.**  
Crystal Unit SMD 3.2x2.5 20.0MHz

MODEL NO.: TZ1565B

REV. NO.: 1

**Revise:**

Rev.	Rev. Page	Rev. Account	Date	Ref. No.	Revised by
1	N/A	Initial release	10/21/10	N/A	Ann Liu



# TAI-SAW TECHNOLOGY CO., LTD.

## Crystal Unit SMD 3.2x2.5 20.0MHz

MODEL NO.: TZ1565B

REV. NO.: 1

### Features:

- Surface Mount Hermetic Package
- Excellent Reliability Performance
- Good Frequency Perturbation and Stability over temperature
- Ultra Miniature Package

RoHS Compliant  
Lead free  
Lead-free soldering

### Description and Applications:

Surface mount 3.2mmx2.5mm crystal unit for use in wireless communications devices, especially for a need of ultra miniature package for mobility.

### Electrical Specifications:

<b>TZ1565B</b>	<b>Specification</b>
Nominal Frequency	20.000000 MHz
Mode of Oscillation	Fundamental
Storage Temperature Range	-40°C to +85°C
Operating Temperature Range	-20°C to +85°C
Frequency Stability over Operating Temperature Range	+/-10 ppm (referred to the value at 25°C)
Frequency Make Tolerance (FL)	+/-10 ppm @ 25°C +/- 3°C
Equivalent Series Resistance (ESR)	50 Ω max
Nominal Drive Level	100 uW typical, 200uW max.
Shunt Capacitance (Co)	5 pF max
Load Capacitance (CL)	15 pF
Insulation Resistance	500 MΩ min./DC 100V
Marking	Laser Marking
Unit Weight	0.017+/-0.005 g

# Mechanical Dimensions (mm):

## Base 1

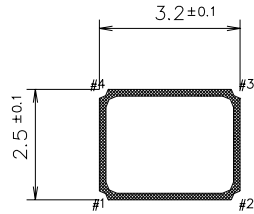

	Pin Connection
#1 pin	IN/OUT
#2 pin	GND
#3 pin	IN/OUT
#4 pin	GND

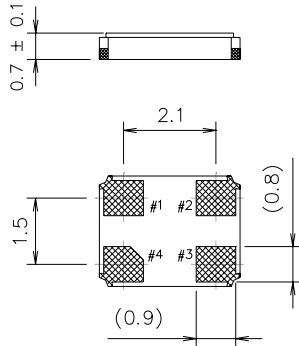

Internal Connections  
(Top View)

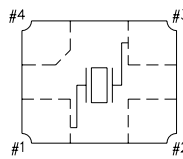

#2, #4 is connected with a cover

## Base 2

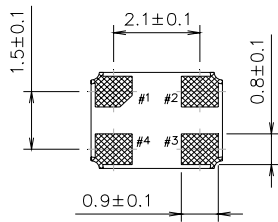

Internal Connections  
(Top View)

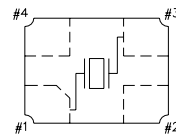

#2, #4 is connected with a cover

## Recommended Land Pattern: (unit: mm)

Reference Footpoint

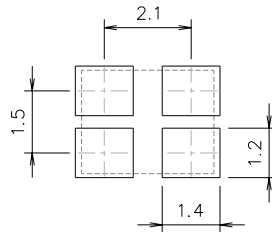

## Marking:

Line 1: Frequency (20.00)

Line 2: TST Logo + Crystal Product Code + Date Code

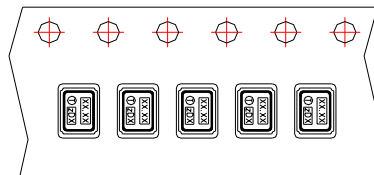
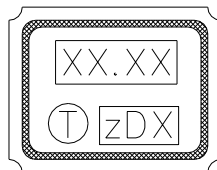

**Product Code Table**

Year	2009	2010	2011	2012
	2013	2014	2015	2016
	2017	2018	2019	2020
product code	Z	z	Z	z

**Date Code Table**

WK01	WK02	WK03	WK04	WK05	WK06	WK07	WK08	WK09	WK10	WK11	WK12	WK13
A	B	C	D	E	F	G	H	I	J	K	L	M
WK14	WK15	WK16	WK17	WK18	WK19	WK20	WK21	WK22	WK23	WK24	WK25	WK26
N	O	P	Q	R	S	T	U	V	W	X	Y	Z
WK27	WK28	WK29	WK30	WK31	WK32	WK33	WK34	WK35	WK36	WK37	WK38	WK39
a	b	c	d	e	f	g	h	i	j	k	l	m
WK40	WK41	WK42	WK43	WK44	WK45	WK46	WK47	WK48	WK49	WK50	WK51	WK52
n	o	p	q	r	s	t	u	v	w	x	y	z

**Reel Dimensions (mm):**

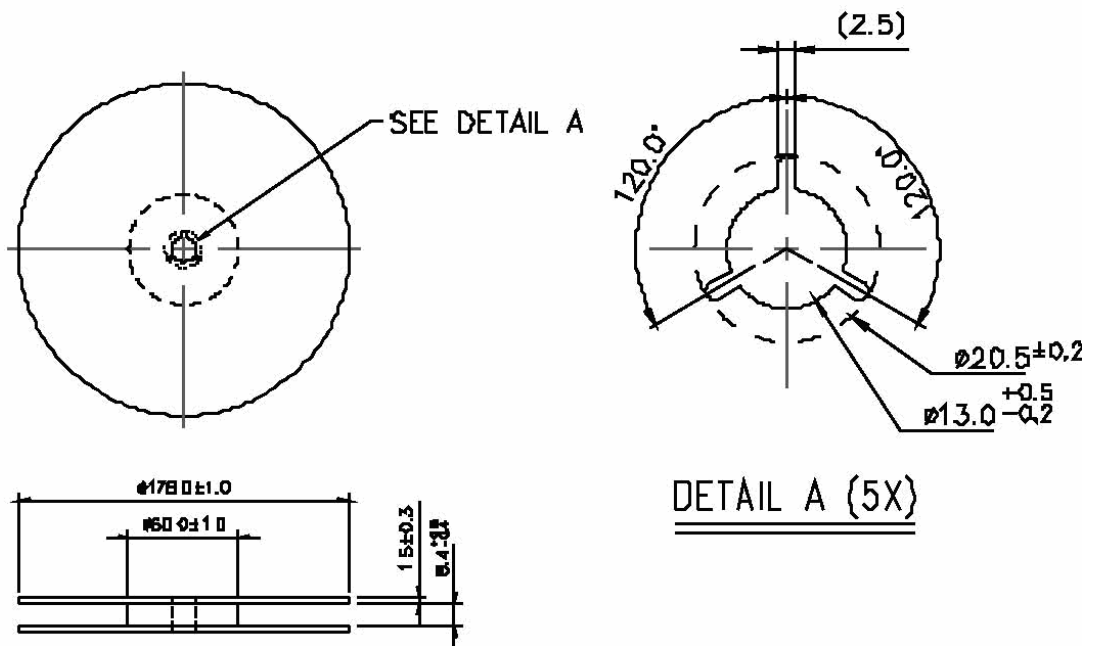

Tape Dimensions (mm):

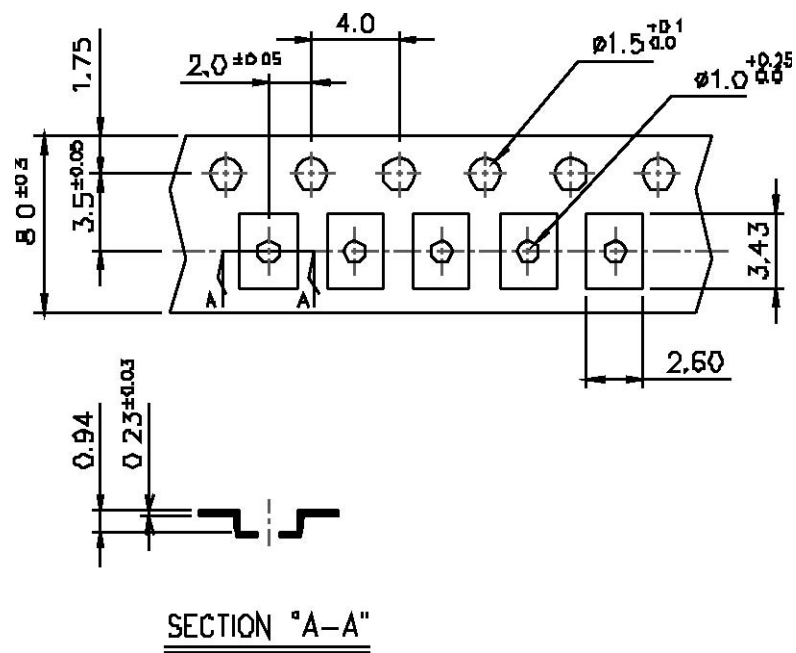

[NOTE]

- 1 UNIT : mm.
- 2 UNLESS OTHERWISE SPECIFIED TOLERANCE ON DIM.  $\pm 0.1$ mm.
- 3 MATERIAL : CONDUCTIVE POLYSTYRENE.
- 4 COLOR : BLACK.
- 5 10 PITCHES CUMULATIVE TOLERANCE  $\pm 0.2$ mm.

Packing Quantity/Packing:

**3K pcs maximum per reel**

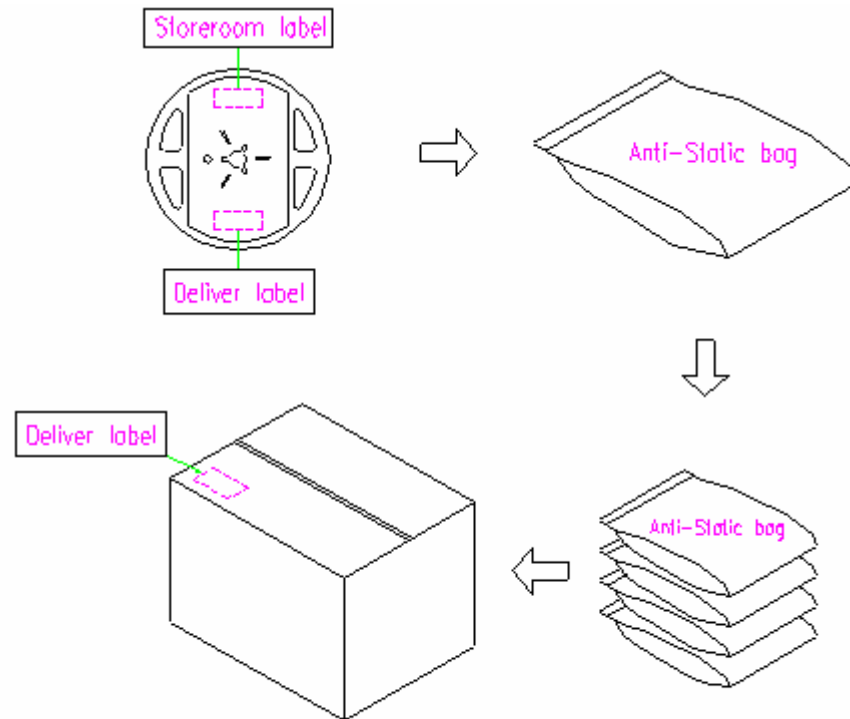

## Reflow Profile:

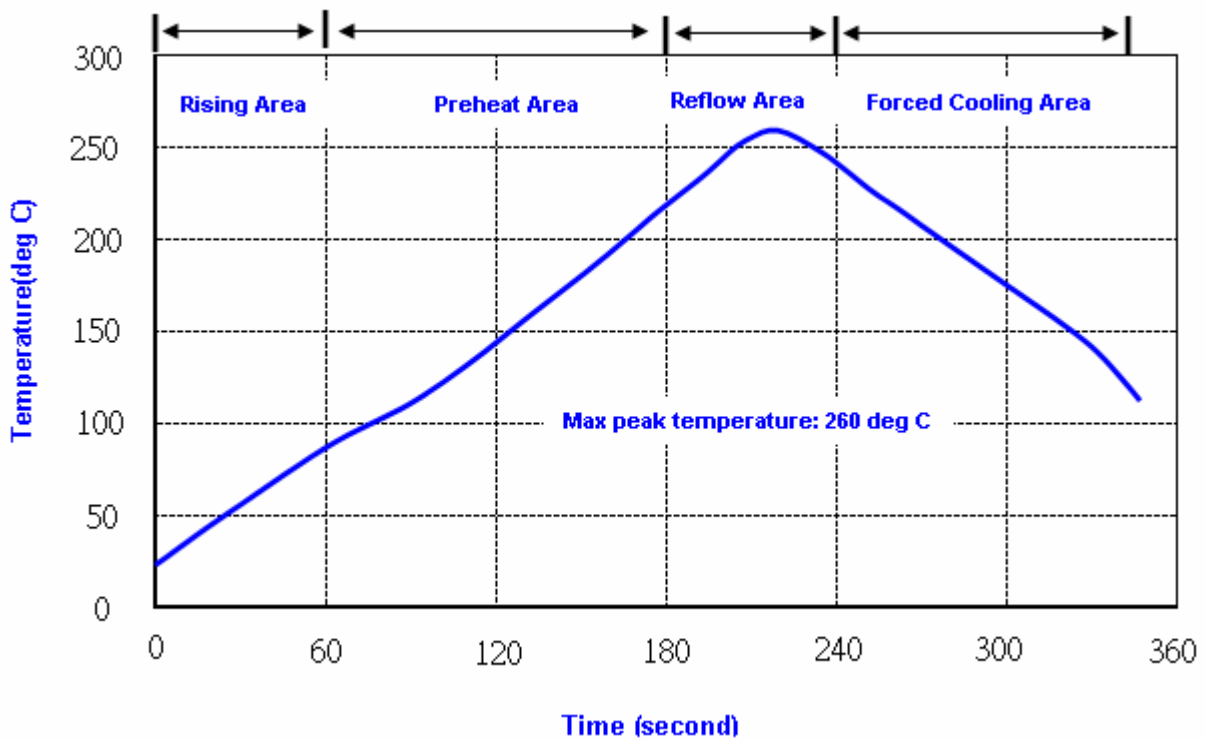

- Note:**
1. Max peak temperature: 260 $\pm$ 5 deg C; Time: 10 $\pm$ 2 sec
  2. Temperature: 217 $\pm$ 5 deg C; Time: 90~100 sec

## Reliability Specifications

Test name	Test process / method	Reference standard
<b>Mechanical characteristics</b>		
resistance to Soldering heat (IR reflow)	Temp./ Duration : 260°C /10sec ×2 times Total time : 4min.(IR-reflow)	EIAJED-4701 -300(301)M(II)
Vibration	Total peak amplitude : 1.5mm Vibration frequency : 10 to 55 Hz Sweep period : 1.0 minute Vibration directions : 3 mutually perpendicular Duration : 2 hr / direc.	MIL-STD 202F method 201A
Mechanical Shock	directions : 3 impacts per axis Acceleration : 3000g's, +20/-0 % Duration : 0.3 ms (total 18 shocks) Waveform : Half-sine	MIL-STD 202F method 213C
Solderability	Solder Temperature:265±5°C Duration time: 5±0.5 seconds.	MIL-STD 883G method 2003
<b>Environmental characteristics</b>		
Thermal Shock	Heat cycle conditions -55 °C (30min) ↔ 125 °C (30min) * cycle time : 10 times	MIL-STD 883G method 1010.7
Humidity test	Temperature : 70 ± 2 °C Relative humidity : 90~95% Duration : 96 hours	MIL-STD 202F method 103B
Dry heat ( Aging test )	Temperature : 125 ± 2 °C Duration : 168 hours	MIL-STD 883G method 1008.2 condition C
PCT test	Pressure: 2.06kg/cm <sup>2</sup> (2.03*10 <sup>5</sup> pa) Temperature : 121 ± 2 °C Relative humidity : 100% Duration : 24 hours	EIAJED-4701-3 B-123A



## X-ON Electronics

Largest Supplier of Electrical and Electronic Components

*Click to view similar products for [Crystals](#) category:*

*Click to view products by [Tai-Saw Technology](#) manufacturer:*

Other Similar products are found below :

[CX3225GB25000M0PPSZ1](#) [718-13.2-1](#) [7A-40.000MAAE-T](#) [FL2000085](#) [99-BU](#) [9B-15.360MBBK-B](#) [9C-7.680MBBK-T](#) [H10S-12.000-18-EXT-TR](#) [ABC2-6.000MHZ-D4Z-T](#) [ABLS-20.000MHZ-D2-T](#) [ABS071-32.768KHZ-6-T](#) [R38-32.768-12.5-5PPM-NPB](#) [BTD1062E05A-513](#) [21U15A-21.4MHZ](#) [RTX-781DF1-S-20.950](#) [LFXTAL066198Cutt](#) [9C-14.31818MBBK-T](#) [A-11.000MHZ-27](#) [ABL-27.000MHZ-B4Y-T](#) [ABM11-132-24.000MHZ-T3](#) [ABM3B1-25.000MHZ-D2Y-T](#) [SPT2A-.032768B](#) [SPT2A.032768G](#) [LFXTAL065253Cutt](#) [LFXTAL066431Cutt](#) [XT9S20ANA14M7456](#) [XT9SNLANA16M](#) [7A-24.576MBBK-T](#) [7B-30.000MBBK-T](#) [CX2520DB16000H0HPQCC](#) [MMCC2R32.7680KHZ](#) [6504-202-1501](#) [6526-202-1501](#) [ABLS-12.000MHZ-B2Y-T](#) [7A-10.000MBBK-T](#) [SG636PCE-20.000MC](#) [3404](#) [CM315D32768EZFT](#) [C1E-24.000-7-2020-R](#) [C1E-19.200-12-1530-X-R](#) [C1E-16.000-12-1530-X-R](#) [ABM11-16.000MHZ-9-B1U-T](#) [FL5000014](#) [EUCA18-3.1872M](#) [FX0800015](#) [425F35E027M0000](#) [FP0800018](#) [MS3V-T1R-32.768kHz-7pF-20PPM-TA-QC-Au](#) [VXM7-1C1-16M000](#) [MS3V-T1R-32.768kHz-9pF-20PPM-TA-QC-Au](#)