



TAI-SAW TECHNOLOGY CO., LTD.

No. 3, Industrial 2nd Rd., Ping-Chen Industrial District,
Taoyuan, 324, Taiwan, R.O.C.

TEL: 886-3-4690038 FAX: 886-3-4697532

E-mail: tstsales@mail.taisaw.com Web: www.taisaw.com

Product Specifications Approval Sheet

Product Description: Crystal Unit SMD 2.5x2.0 26.0MHz

TST Part No.: TZ2031C

Customer Part No.: _____

Customer signature required
Company: _____
Division: _____
Approved by : _____
Date: _____

Checked by: _____ Yifan Chen *Yifan*

Approved by: _____ Kelly Huang *Kelly Huang*

Date: _____ 03/01/2013

1. Customer signed back is required before TST can proceed with sample build and receive orders.
2. Orders received without customer signed back will be regarded as agreement on the specifications.
3. Any specifications changes must be approved upon by both parties and a new revision of specifications shall be released to reflect the changes.



TAI-SAW TECHNOLOGY CO., LTD.
Crystal Unit SMD 2.5x2.0 26.0MHz

MODEL NO.: TZ2031C

REV. NO.: 1

Revise:

Rev.	Rev. Page	Rev. Account	Date	Ref. No.	Revised by
1	N/A	Initial release	03/01/13'	N/A	Yifan Chen



TAI-SAW TECHNOLOGY CO., LTD.

Crystal Unit SMD 2.5x2.0 26.0MHz

MODEL NO.: TZ2031C

REV. NO.: 1

Features:

- Surface Mount Hermetic Package
- Excellent Reliability Performance
- Good Frequency Perturbation and Stability over temperature
- Ultra Miniature Package

RoHS Compliant
Lead free
Lead-free soldering

Description and Applications:

Surface mount 2.5mmx2.0mm crystal unit for use in wireless communications devices, especially for a need of ultra miniature package for mobility.

Electrical Specifications:

TZ2031C	Specification
Nominal Frequency	26.000000 MHz
Mode of Oscillation	Fundamental
Storage Temperature Range	-40°C to +105°C
Operating Temperature Range	-30°C to +85°C
Frequency Stability over Operating Temperature Range	+/-15 ppm (referred to the value at 25°C)
Frequency Make Tolerance (FL)	+/-10 ppm @ 25°C +/- 3°C
Equivalent Series Resistance (ESR)	100 Ω max
Nominal Drive Level	10uW typical and 100uW max
Shunt Capacitance (Co)	3.0 pF max
Load Capacitance (CL)	12 pF
Insulation Resistance	500 MΩ min./DC 100V
Marking	Laser Marking
Unit Weight	9.5 +/-0.5mg

Mechanical Dimensions (mm):

Base 1

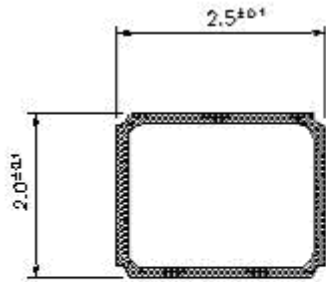

	Pin Connection
#1 pin	IN/OUT
#2 pin	GND
#3 pin	IN/OUT
#4 pin	GND

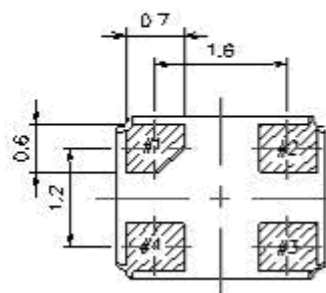
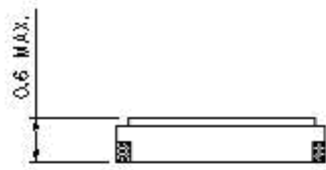

Internal Connections (Top View)

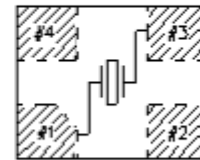

Base 2

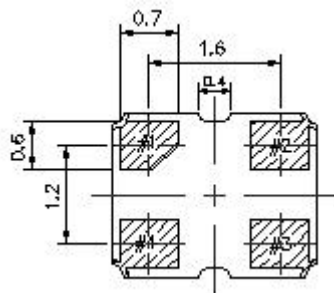

Internal Connections (Top View)

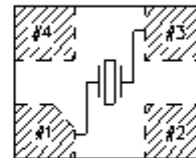

Recommended Land Pattern: (unit: mm)

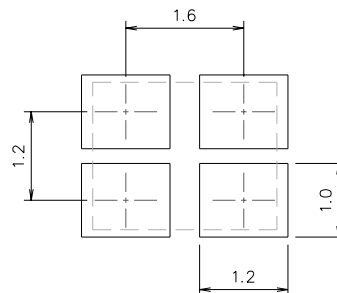

Marking:

Line 1: Frequency (26.0)

Line 2: TST Logo + Date Code + Product Code

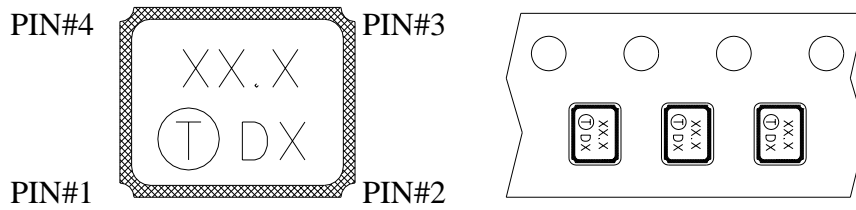

The inner vision of PIN#1,PIN#4 side is XTAL blank mounting pad.

Date Code Table

WK01	WK02	WK03	WK04	WK05	WK06	WK07	WK08	WK09	WK10	WK11	WK12	WK13
A	B	C	D	E	F	G	H	I	J	K	L	M
WK14	WK15	WK16	WK17	WK18	WK19	WK20	WK21	WK22	WK23	WK24	WK25	WK26
N	O	P	Q	R	S	T	U	V	W	X	Y	Z
WK27	WK28	WK29	WK30	WK31	WK32	WK33	WK34	WK35	WK36	WK37	WK38	WK39
a	b	c	d	e	f	g	h	i	j	k	l	m
WK40	WK41	WK42	WK43	WK44	WK45	WK46	WK47	WK48	WK49	WK50	WK51	WK52
n	o	p	q	r	s	t	u	v	w	x	y	z

Product Code Table:

Year						product code
2009	2011	2013	2015	2017	2019	X
2010	2012	2014	2016	2018	2020	X

Reel Dimensions (mm):

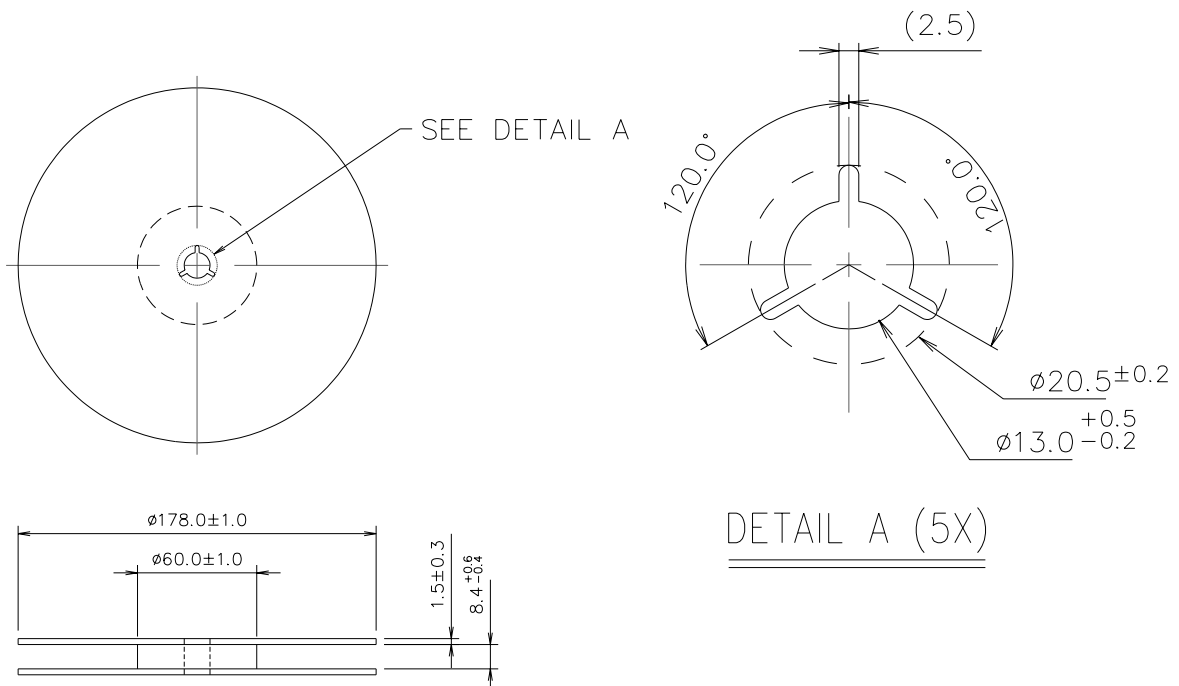

Tape Dimensions (mm):

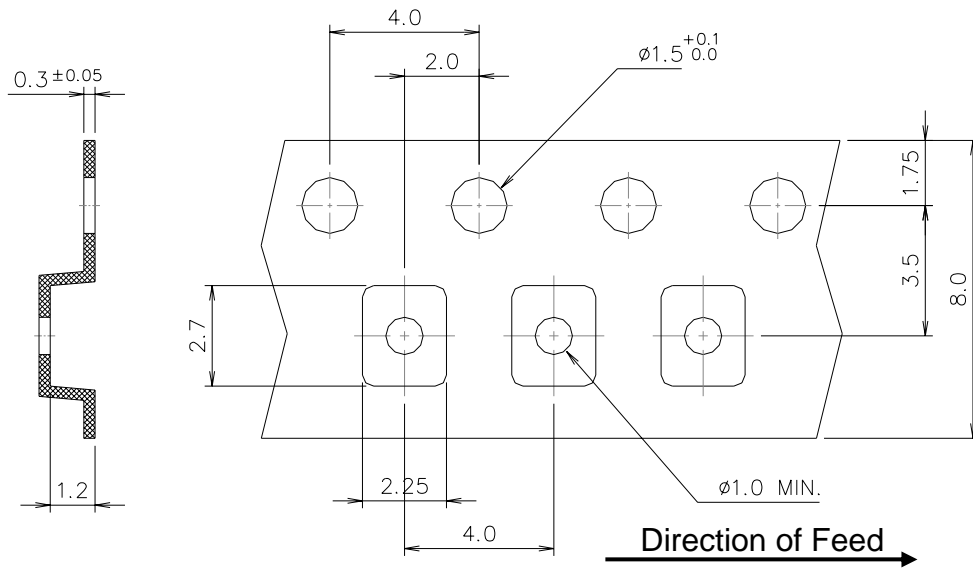

[NOTE]:

1. Unless otherwise specified tolerance on dimension +/-0.1 mm.
2. Material: conductive polystyrene with color black.
3. 10 pitch cumulative tolerance +/-0.2 mm.

Packing Quantity/Packing:

3K pcs maximum per reel

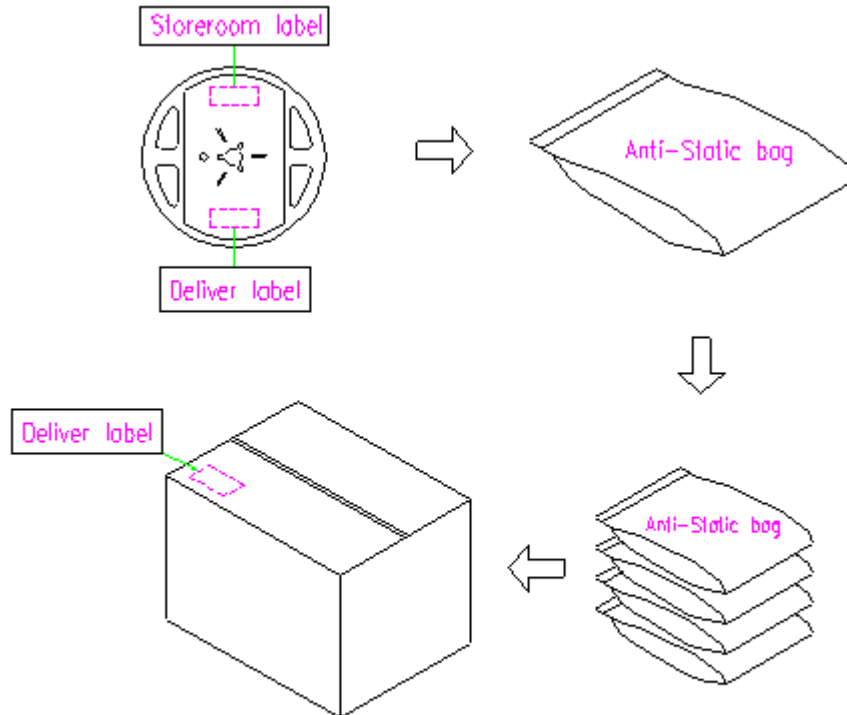

Reflow Profile:

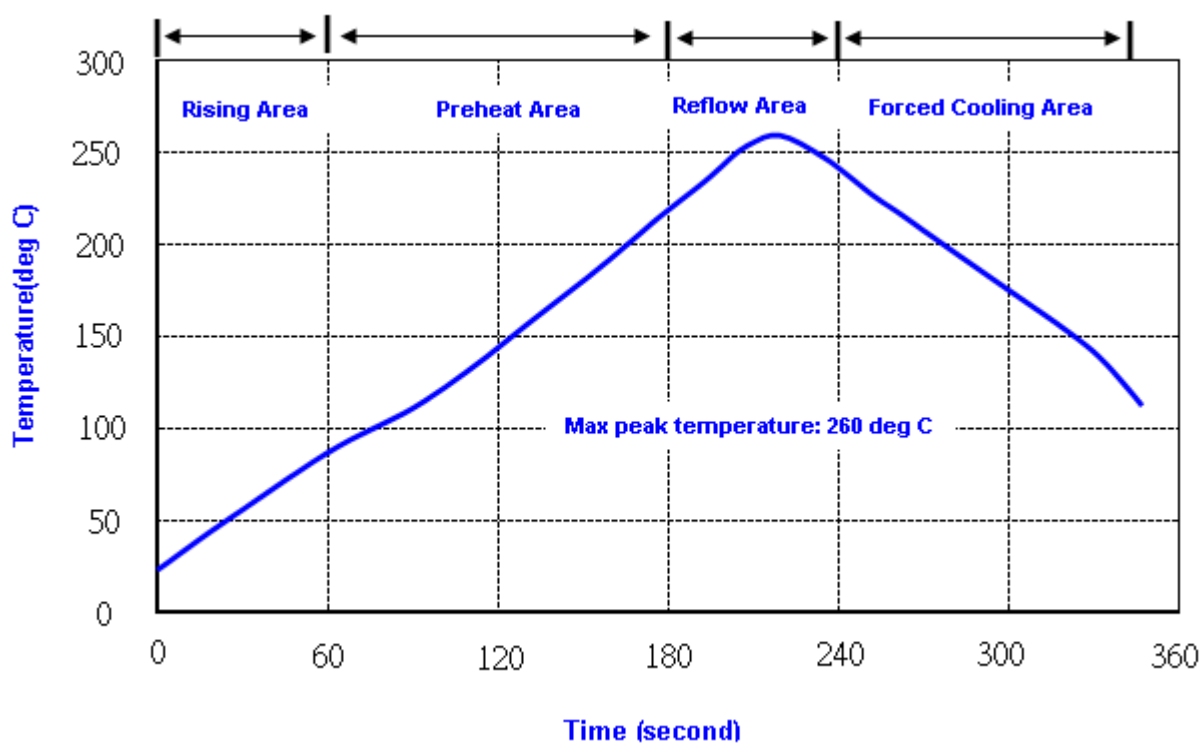

- Note: 1. Max peak temperature: 260 \pm 5 deg C; Time: 10 \pm 2 sec
2. Temperature: 217 \pm 5 deg C; Time: 90~100 sec

X-ON Electronics

Largest Supplier of Electrical and Electronic Components

Click to view similar products for [Crystals](#) category:

Click to view products by [Tai-Saw Technology](#) manufacturer:

Other Similar products are found below :

[CX3225GB25000M0PPSZ1](#) [718-13.2-1](#) [7A-40.000MAAE-T](#) [FL2000085](#) [99-BU](#) [9B-15.360MBBK-B](#) [9C-7.680MBBK-T](#) [H10S-12.000-18-EXT-TR](#) [ABC2-6.000MHZ-D4Z-T](#) [ABLS-20.000MHZ-D2-T](#) [ABS071-32.768KHZ-6-T](#) [R38-32.768-12.5-5PPM-NPB](#) [BTD1062E05A-513](#) [21U15A-21.4MHZ](#) [RTX-781DF1-S-20.950](#) [LFXTAL066198Cutt](#) [9C-14.31818MBBK-T](#) [A-11.000MHZ-27](#) [ABL-27.000MHZ-B4Y-T](#) [ABM11-132-24.000MHZ-T3](#) [ABM3B1-25.000MHZ-D2Y-T](#) [SPT2A-.032768B](#) [SPT2A.032768G](#) [LFXTAL065253Cutt](#) [LFXTAL066431Cutt](#) [XT9S20ANA14M7456](#) [XT9SNLANA16M](#) [7A-24.576MBBK-T](#) [7B-30.000MBBK-T](#) [CX2520DB16000H0HPQCC](#) [MMCC2R32.7680KHZ](#) [6504-202-1501](#) [6526-202-1501](#) [ABLS-12.000MHZ-B2Y-T](#) [7A-10.000MBBK-T](#) [SG636PCE-20.000MC](#) [3404](#) [CM315D32768EZFT](#) [C1E-24.000-7-2020-R](#) [C1E-19.200-12-1530-X-R](#) [C1E-16.000-12-1530-X-R](#) [ABM11-16.000MHZ-9-B1U-T](#) [FL5000014](#) [EUCA18-3.1872M](#) [FX0800015](#) [425F35E027M0000](#) [FP0800018](#) [MS3V-T1R-32.768kHz-7pF-20PPM-TA-QC-Au](#) [VXM7-1C1-16M000](#) [MS3V-T1R-32.768kHz-9pF-20PPM-TA-QC-Au](#)