



**Thick Film Chip Resistor Arrays
Thick Film Chip Resistor Networks
(CN Series Standard)
Halogen-Free**

Document No.	TCN-XX0S001S
Revise Date	2016/06/27
page number	1 /12

1. Scope :

This specification applies for the CN series of thick film chip resistor arrays & chip resistor networks made by TA-I.

2. Construction , Dimensions , Schematic :

2.1 Construction :

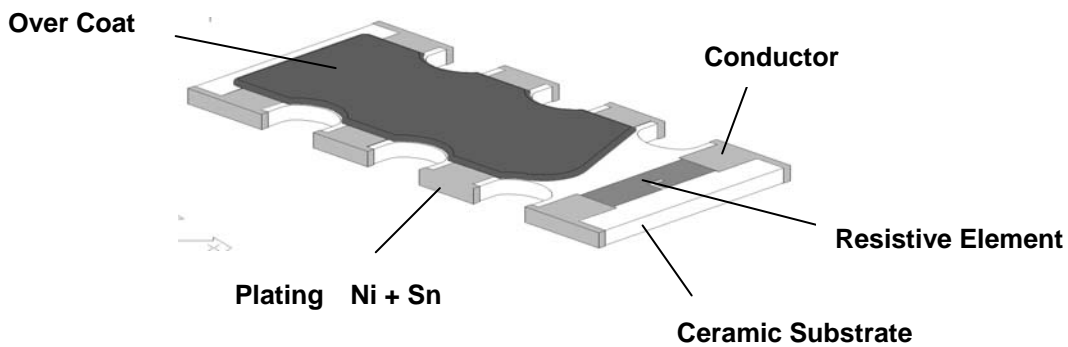

2.1.1 Chip Resistor Arrays :

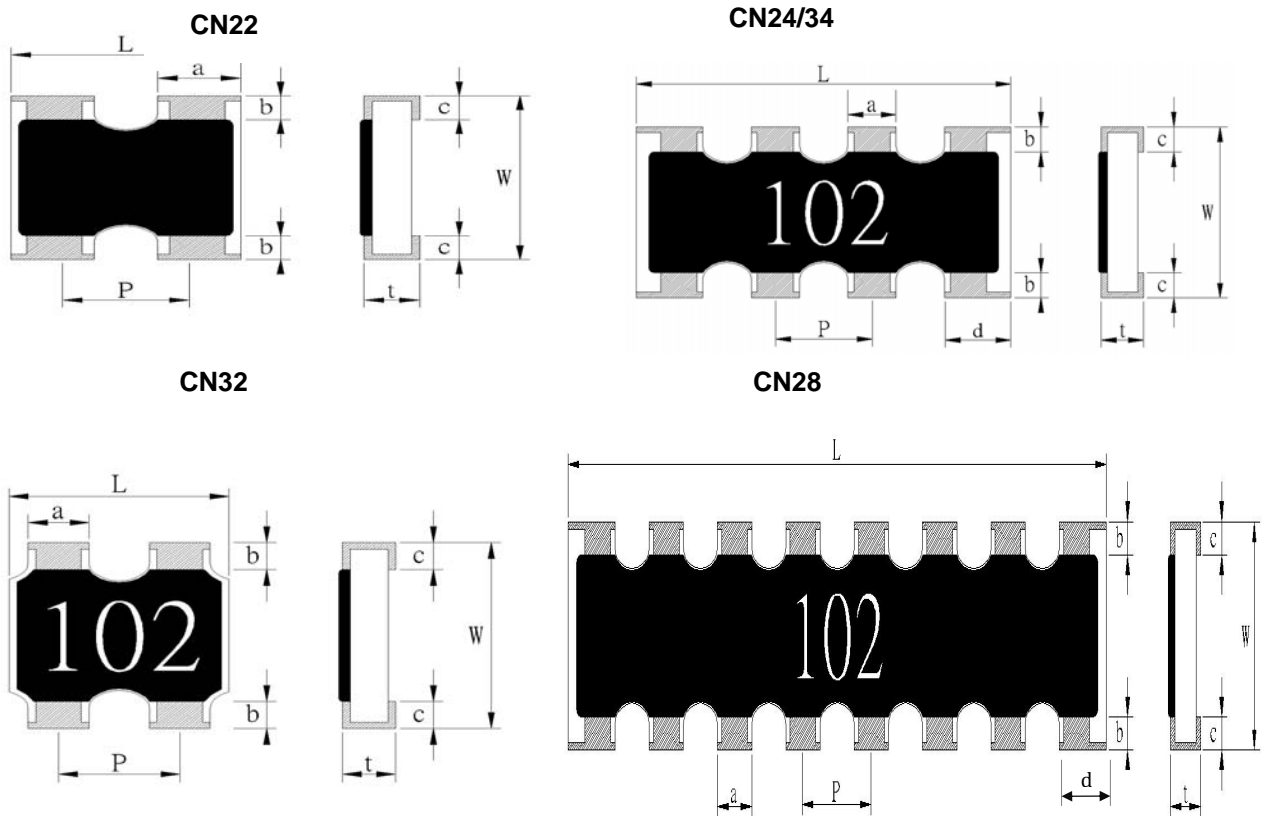



Thick Film Chip Resistor Arrays
Thick Film Chip Resistor Networks
(CN Series Standard)
Halogen-Free

Document No.	TCN-XX0S001S
Revise Date	2016/06/27
page number	2 /12

2.1.2 Chip Resistor Networks

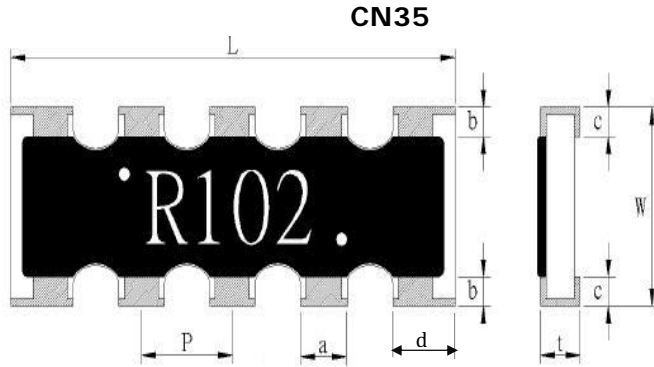

2.2 Dimension :

UNIT: mm

Type	L	W	t	P	a	b	c	d
CN22	1.0 ± 0.1	1.0 ± 0.1	0.35 ± 0.1	0.65 ± 0.1	0.33 ± 0.1	0.15 ± 0.1	0.25 ± 0.1	0.33±0.1
CN24	2.0 ± 0.1	1.0 ± 0.1	0.4 ± 0.1	0.5 ± 0.05	0.3 ± 0.1	0.15 ± 0.1	0.25 ± 0.1	0.4±0.1
CN28	4.0 ± 0.2	1.6 ± 0.15	0.4 ± 0.1			0.25 ± 0.1		
CN32	1.6 ± 0.15	1.6 ± 0.15	0.45 ± 0.1	0.76 ± 0.1	0.45 ± 0.1	0.3 ± 0.2	0.3 ± 0.2	0.45±0.1
CN34	3.2 ± 0.2	1.6 ± 0.15	0.5 ± 0.1	0.8 ± 0.05	0.45 ± 0.1	0.3 ± 0.2	0.3 ± 0.2	0.6±0.1
CN35				0.64 ± 0.05	0.35 ± 0.1			0.5±0.1

2.3 Schematic :

CN35

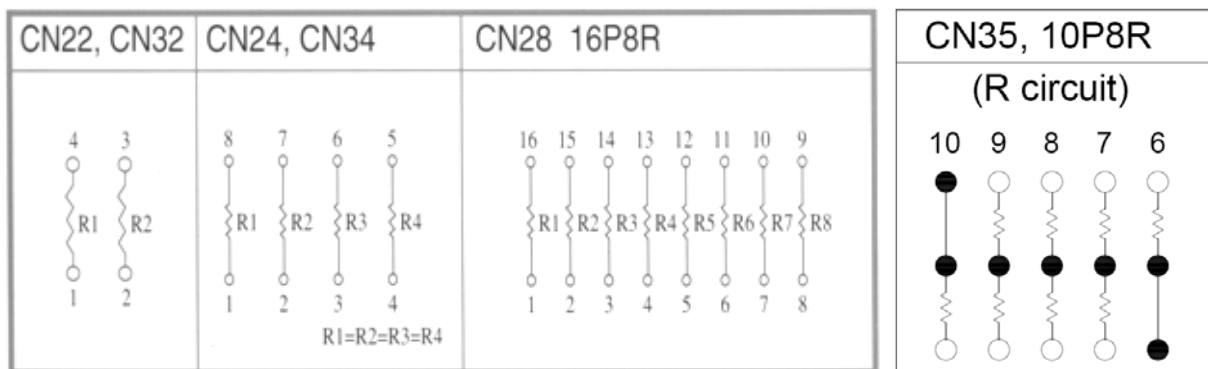
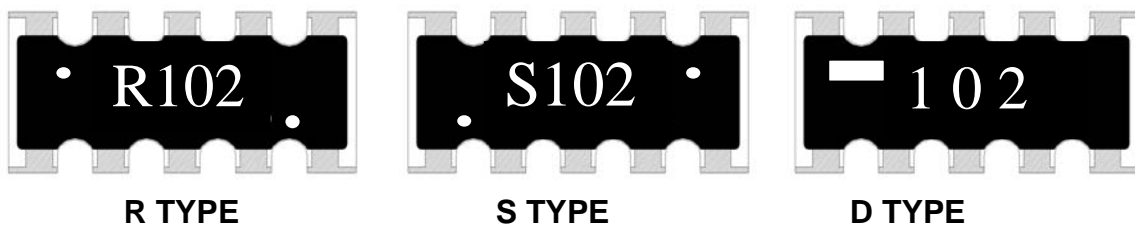



Thick Film Chip Resistor Arrays
Thick Film Chip Resistor Networks
(CN Series Standard)
Halogen-Free

Document No.	TCN-XX0S001S
Revise Date	2016/06/27
page number	3 /12

3. Type Designation:

3.1 Chip Resistor Arrays

CN

34

J

TN

103

Product Code size Tolerance Packaging Nominal Resistance
 CN : Chip Resistor Array Power Rating

22-0402*2 24-0402*4 28-0402*8 32-0603*2 34-0603*4 35-0603*5	J-±5% G-±2% F-±1%	T- Paper Tape <hr/> N : normal (RoHS Exclusion clause) W : Totally Lead free	3 digits E.G.: (E-24) 103 = 10KΩ 5R6 = 5.6Ω 4 digits E.G. : (E-96) 1540 = 154Ω 43R2 = 43.2Ω
--	-------------------------	---	--

3.2 Chip Resistor Networks

CN

35

J

TN

R

103

Product Code Size Tolerance Packaging Circuit Resistance value
 CN : Chip Resistor Array Power Rating

35-0603*5	J-±5%	T-Paper tape <hr/> N : normal (RoHS Exclusion clause) W : Totally Lead free	R-10P8R 5.10 com	3 digits E.G. : (E-24)103 = 10KΩ
-----------	-------	--	------------------	-------------------------------------

Note :

TN : Lead-Free products packaged by paper tape.



**Thick Film Chip Resistor Arrays
Thick Film Chip Resistor Networks
(CN Series Standard)
Halogen-Free**

Document No.	TCN-XX0S001S
Revise Date	2016/06/27
page number	4 /12

4. Ratings & Characteristics :

Type	Power Rating at 70°C	Rating Voltage	Max. Working Voltage	Max. Over Load Voltage	Operating Temp. (°C)	Resistance Tolerance (%)	Resistance Range (Ω)	Temp Co-efficient PPM/°C
CN22	1/16W	Refer 4.2	25V	50V	-55 ↓ +125°C	±5% ±2% ±1%	10Ω~1MΩ	±250
CN24								
CN28								
CN32			50V	100V		10Ω~1MΩ	±200	
CN34			50V	100V				
CN35			25V	50V		56Ω~100kΩ	±200	
CN34			50V	100V				
CN32			50V	100V				
CN22			25V	50V		3.0Ω~9.1Ω	±400	
CN24			25V	50V				
						±5%		±500

0Ω THICK FILE CHIP RESISTOR ARRAYS			
Type	Rate Current	Max Overload Current	Resistance Range
CN Series	1A	2.5A	50mΩ MAX

4.1 Derating Curve :

For resistors operated at ambient temperature over 70°C , power rating shall be derated in accordance with figure 1.

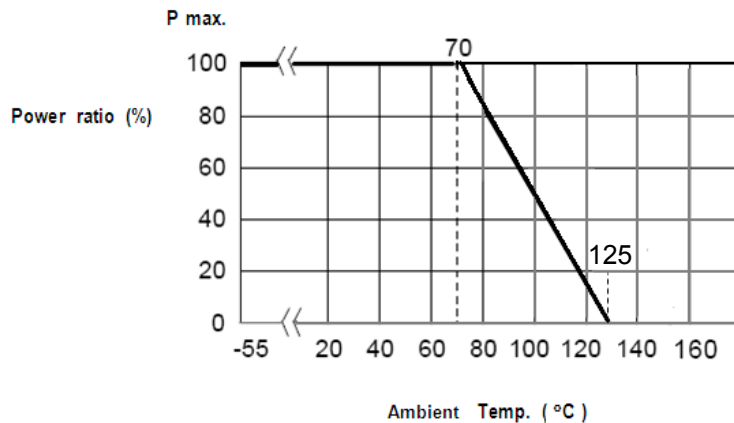

Figure 1

4.2 Rated Voltage:

The rated voltage is calculated by the following formula:

$$E = \sqrt{P * R}$$

E=Rated Voltage(V)
P=Rated Power(W)
R=Resistance Value(Ω)

E.G. : What is CN34JTN102 the rated voltage ?

CN34JTN102 P:1/16W ; R:102 = 1KΩ = 1000Ω

$$E = \sqrt{0.0625(W) * 1000(\Omega)} = 7.9 (V)$$



**Thick Film Chip Resistor Arrays
Thick Film Chip Resistor Networks
(CN Series Standard)
Halogen-Free**

Document No.	TCN-XX0S001S
Revise Date	2016/06/27
page number	5 /12

5. Reliability Tests:

Test Items	Reference standard	Condition of Test	Test Limits (ΔR)
Temperature Coefficient of Resistance	IEC60115-1-4.8 JIS-C5201-1-4.8	-55~ +125 °C	Refer 4.0
Short Time Overload	IEC60115-1-4.13 JIS-C5201-1-4.13	2.5 X rated voltage for 5 sec	$\pm(2.0\%+0.1\Omega)$ 0 Ω : 50 m Ω or less
Intermittent Overload	IEC60115-1-4.39 JIS-C5201-1-4.39	2.5X rated voltage or Max Overloading Voltage , 1 sec "ON" 25 sec "OFF" , 10000 cycles	$\pm(5.0\%+0.1\Omega)$ 0 Ω : 50m Ω or less
Load Life	IEC60115-1-4.25.1 JIS-C5201-1-4.25.1	1000 hours at rated voltage , 70°C , 1.5hours "ON" , 0.5hour "OFF"	1%: $\pm(1.0\%+0.05\Omega)$ 5%: $\pm(3.0\%+0.1\Omega)$ 0 Ω :100 m Ω or less
Load Life with Humidity	IEC60115-1-4.24 JIS-C5201-1-4.24	1000 hours at rated voltage , 40 \pm 2°C, 90~95% RH 1.5hours "ON" , 0.5hour "OFF"	1%: $\pm(1.0\%+0.05\Omega)$ 5%: $\pm(3.0\%+0.1\Omega)$ 0 Ω :100 m Ω or less
Rapid Change of Temperature	IEC60115-1-4.19 JIS-C5201-1-4.19	-55°C (30 min.) / +155 °C(30 min.) 5 cycles	1%: $\pm(0.5\%+0.05\Omega)$ 5%: $\pm(1.0\%+0.05\Omega)$ 0 Ω :50 m Ω or less
Solderability	IEC60115-1-4.17 JIS-C5201-1-4.17	245 \pm 5°C solder, 2 \pm 0.5 sec dwell. Solder : Sn96.5 / Ag3.0 / Cu0.5	At least 95% of surface area of electrode shall be covered with new solder.
Core body	IEC60115-1-4.15 JIS-C5201-1-4.15	Pressure 1.0 kgf a R0.5 pressure rod for 10 sec	Without mechanical damage such as breaks. Electrical characteristics shall be satisfied
Dielectric Withstanding Voltage (Voltage Proof)	IEC60115-1-4.7 JIS-C5201-1-4.7	Applying voltage 100V for 1 minute.	No abnormalities such as flashover, burning dielectric breakdown shall appear.
Resistance to Solder Heat	IEC60115-1-4.18 JIS-C5201-1-4.18	270 \pm 5°C solder , 10 \pm 1 sec dwell .	0.5%,1%: $\pm(1.0\%+0.05\Omega)$ 2%,5%: $\pm(2.0\%+0.1\Omega)$ 0 Ω : 50m Ω or less

Note* : RCWV : Rated continuous working voltage .



Thick Film Chip Resistor Arrays
Thick Film Chip Resistor Networks
(CN Series Standard)
Halogen-Free

Document No.	TCN-XX0S001S
Revise Date	2016/06/27
page number	6 / 12

6. Marking

6.1 ±2% & ±5%(E24) : CN24 / 28 / 32 / 34 / 35

Resistance value is expressed by 3 digits, the first two digits represent the significant figures of nominal resistance value in Ω , and the third digit represents exponent for base of 10.

E.G. $472 = 47 \times 10^2 = 4700 \Omega = 4.7K \Omega$

6.2 ±1% (E96) : CN24 / 28 / 32 / 34

Resistance value is expressed by 4 digits, the first three digits represent the significant figures of nominal resistance value in Ω , and the fourth digit represents exponent for base of 10.

E.G. $4701 = 470 \times 10^1 = 4700 \Omega = 4.7k \Omega$

6.3 No Marking for CN22

7. Taping & Reel

7.1 Taping Dimensions

7.1.1 2 mm pitch paper

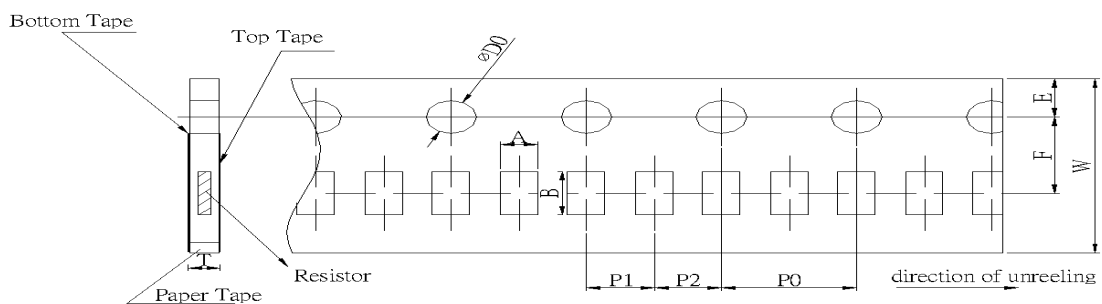

UNIT: mm

Type	A	B	W	F	E	P1	P2	P0	ϕ D0	T0
CN22	1.2±0.15	1.2±0.1	8.0±0.2	3.5±0.05	1.75±0.1	2.0±0.1	2.0±0.05	4.0±0.1	+0.1	0.45±0.1
CN24		2.2±0.2							-0	0.64±0.1



**Thick Film Chip Resistor Arrays
Thick Film Chip Resistor Networks
(CN Series Standard)
Halogen-Free**

Document No.	TCN-XX0S001S
Revise Date	2016/06/27
page number	7 /12

7.1.2 4 mm pitch paper

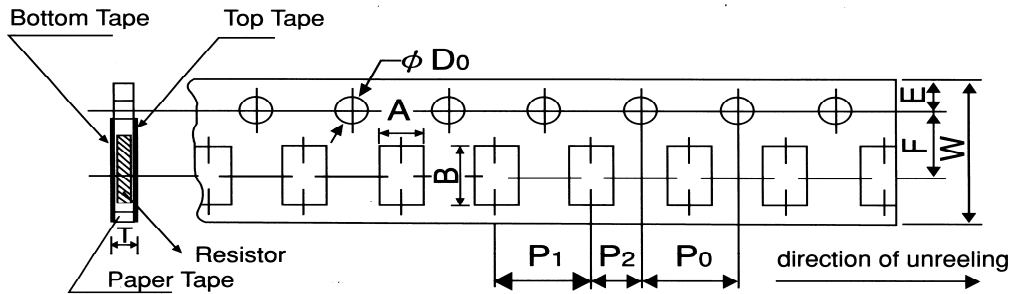

UNIT: mm

Type	A	B	W	F	E	P1	P2	P0	ϕD_0	T
CN28	1.9±0.2	4.3±0.2	8.0±0.2	3.5±0.05	1.75±0.1	4.0±0.1	2.0±0.05	4.0±0.1	1.5 ^{+0.1} ₋₀	0.84±0.1
CN32	1.8±0.2	1.8±0.2								
CN34, 35	2.0±0.15	3.6±0.2								

Package Type	Paper Tape			
	4 mm pitch		2 mm pitch	
	178mm/R	250mm/R	178mm/R	250mm/R
CN22			10000	20000
CN24			10000	20000
CN28	5000			
CN32	5000			
CN34	5000	10000		
CN35	5000	10000		

7.2 Reel Specifications

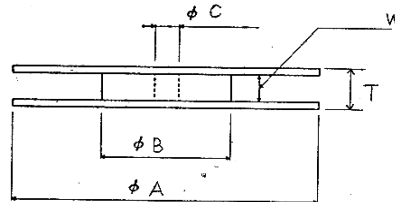
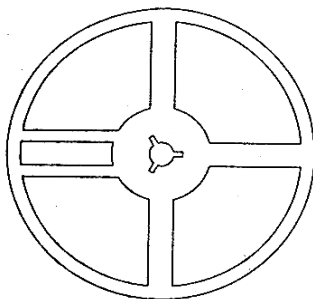

UNIT: mm

Type	ϕA	ϕB	ϕC	W	T
CN22/24/28 CN32/34/35	178.0 ± 2.0	60.0 ± 1.0	13.0 ± 1.0	9.0 ± 1.0	11.5 ± 1.0



**Thick Film Chip Resistor Arrays
Thick Film Chip Resistor Networks
(CN Series Standard)
Halogen-Free**

Document No.	TCN-XX0S001S
Revise Date	2016/06/27
page number	8 /12

7.3 Peel off Strength:

Peel -off force of paper and blister tape is in accordance with "JIS-C5202" that is , 0.1 to 0.7 N at a peel-off speed of 300 mm / minute.

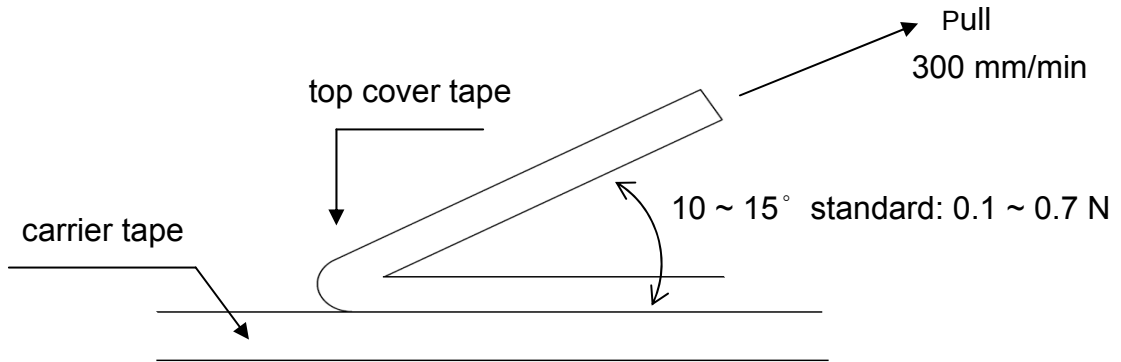

8. Label

8.1 Manufacture Label :

8.1.1 Chip Resistor Array : Normal (RoHS Exclusion clause)

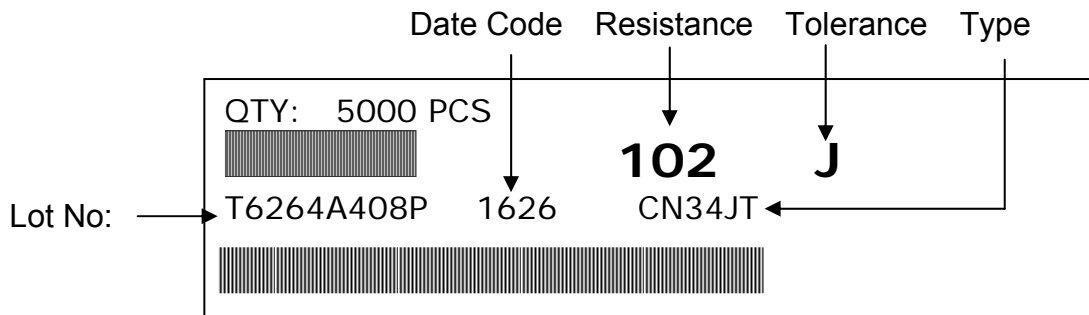

8.1.2 Chip Resistor Array : Totally Lead free

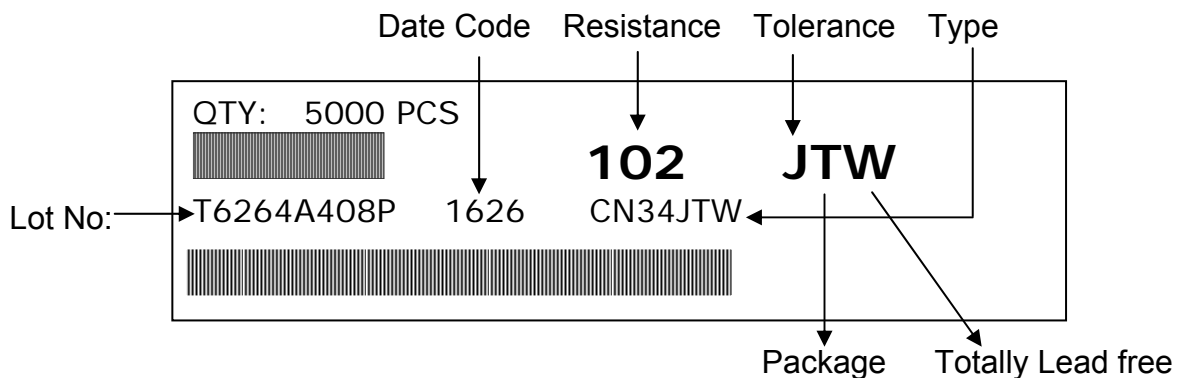



**Thick Film Chip Resistor Arrays
Thick Film Chip Resistor Networks
(CN Series Standard)
Halogen-Free**

Document No.	TCN-XX0S001S
Revise Date	2016/06/27
page number	9 /12

8.1.3 Chip Resistor Networks : Normal (RoHS Exclusion clause)

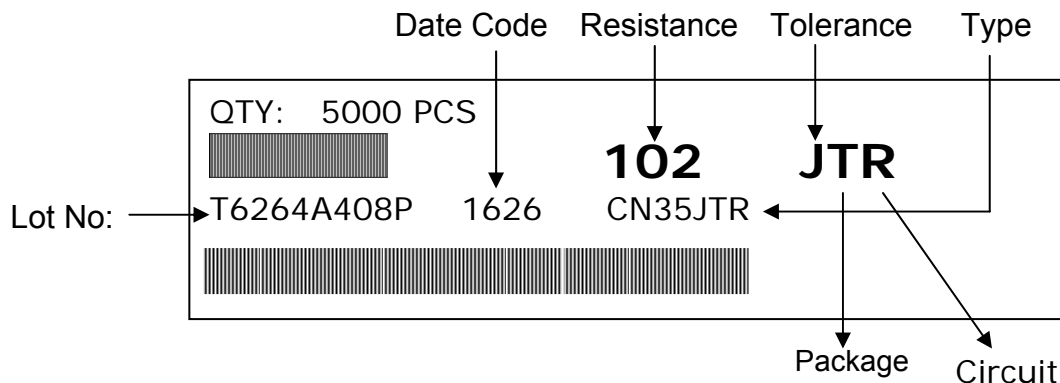

8.1.4 Chip Resistor Networks : Totally Lead free

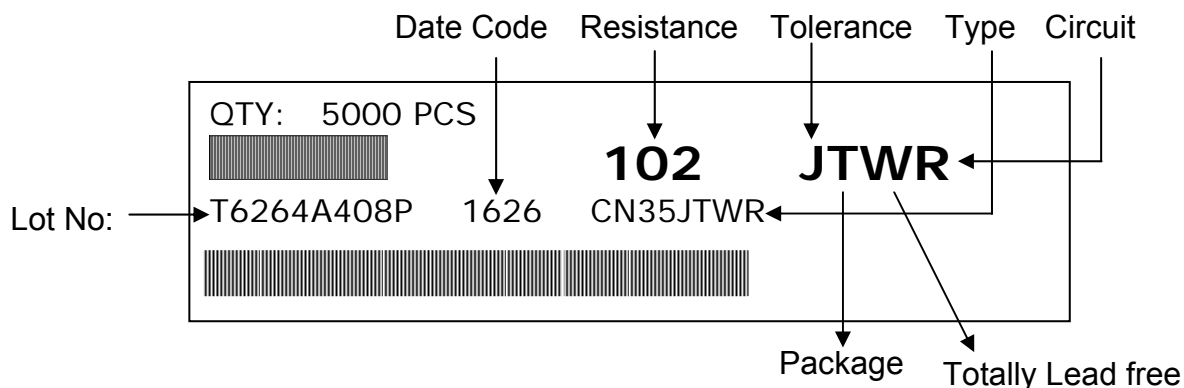

8.2. Customer Label (By customer request) :

8.2.1 Chip Resistor Array :

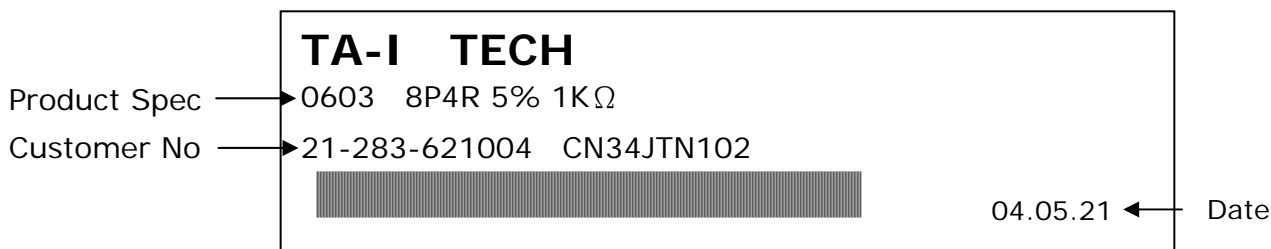

8.2.2 Chip Resistor Networks :

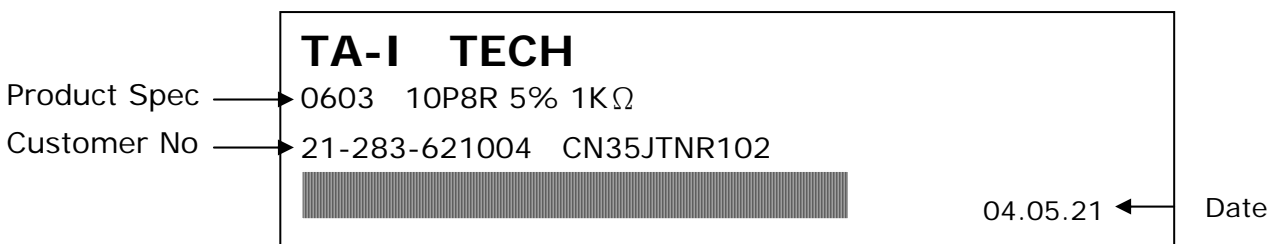



**Thick Film Chip Resistor Arrays
Thick Film Chip Resistor Networks
(CN Series Standard)
Halogen-Free**

Document No.	TCN-XX0S001S
Revise Date	2016/06/27
page number	10 /12

9. Recommended land patterns :

9.1 CN22,CN32,CN34,CN35

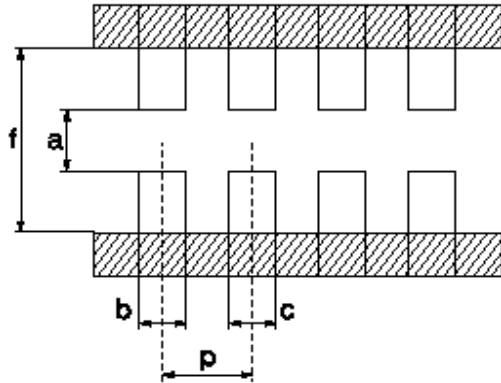

Type	Size	Land pattern				
		Dimension (mm)				
		a	b	c	p	f
CN	22	0.5	0.35~0.4	0.35~0.4	0.65	1.4~1.5
CN	32	0.7~0.9	0.4~0.5	0.4~0.5	0.8	2.2~2.6
CN	34	0.7~0.9	0.4~0.5	0.4~0.5	0.8	2.2~2.6
CN	35	0.7~0.9	0.4~0.5	0.3~0.4	0.64	2.2~2.6

9.2 CN24 ,CN28

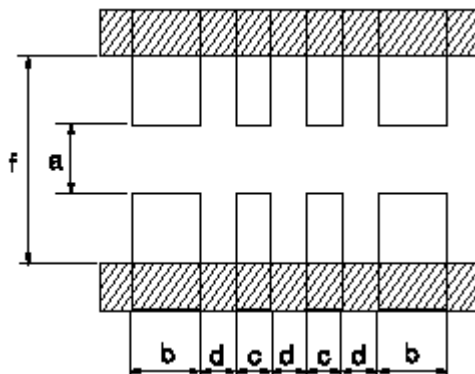

Type	Size	Land pattern				
		Dimension (mm)				
		a	b	c	d	f
CN	24	0.4	0.525	0.25	0.25	1.4
CN	28	1.0	0.425	0.25	0.25	2.0



Thick Film Chip Resistor Arrays
Thick Film Chip Resistor Networks
(CN Series Standard)
Halogen-Free

Document No.	TCN-XX0S001S
Revise Date	2016/06/27
page number	11 /12

10. Recommend IR – Reflow profile : (solder : Sn96.5 / Ag3 / Cu0.5)

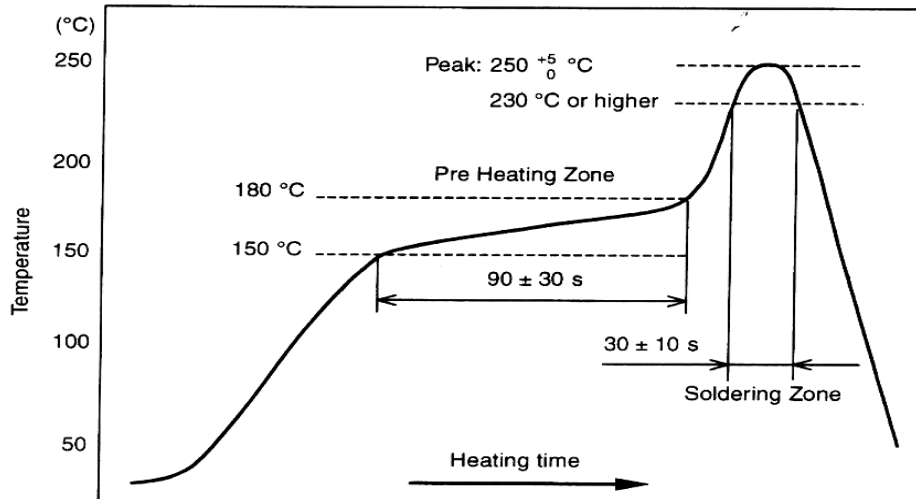

Peak : $250 \begin{matrix} +5 \\ -0 \end{matrix}$ °C , 5 sec

Pre – heat Zone : 150 to 180 °C , 90 ± 30 sec

Soldering Zone : 230°C or higher , 30 ± 10 sec

11. Storage Conditions:

Temperature : 5 to 35 °C

Related Humidity :40 to 75% RH

12. Shelf Life :

2 Years from manufacturing date.

13. ECN :

Engineering Change Notice: The customer will be informed with ECN if there is significant modification on the characteristics and materials described in Approval Sheet.



**Thick Film Chip Resistor Arrays
Thick Film Chip Resistor Networks
(CN Series Standard)
Halogen-Free**

Document No.	TCN-XX0S001S
Revise Date	2016/06/27
page number	12 /12

14. Manufacturing Country & City :

TA-I TECHNOLOGY CO., LTD. (Taiwan– Tao Yuan)

Tel: 886-3-3246169 Fax : 886-3-3246167

Associated companies :

(1) FORTUNE TASK RESISTOR FACTORY (China – Dongguan)

Tel : 86-769-8339-4790~3 Fax : 86-769-8339-4794

(2) TA-I TECHNOLOGY (DONGGUAN) CO., LTD. (China –Dongguan)

Tel : 86-769-8339-4790~3 Fax : 86-769-8339-4794

(3) TA-I TECHNOLOGY (SU ZHOU) CO., LTD. (China – Su Zhou)

Tel :86- 512-63457879 Fax : 86-512-63457869

(4) TAI OHM ELECTRONICS (M) SDN. BHD. (Malaysia – Penang)

Tel :604- 3900480 Fax : 604-3901481

(5) P.T.TAI ELECTRONICS Indonesia (Indonesia – Jakarta)

Tel : 62-21-89830123 Fax : 62-21-89830703

X-ON Electronics

Largest Supplier of Electrical and Electronic Components

Click to view similar products for [Resistor Networks & Arrays](#) category:

Click to view products by [TA-I Tech](#) manufacturer:

Other Similar products are found below :

[CSC06A0122K0GEJ](#) [CSC08A01470KGEK](#) [M8340105K1002FGD03](#) [M8340105M4700JGD03](#) [M8340107K1471FGD03](#)
[M8340108K2402GGD03](#) [M8340108K3240FGD03](#) [M8340108K3242FGD03](#) [M8340108K3743FGD03](#) [M8340108K6192FGD03](#)
[M8340109K2002FCD03](#) [M8340109K2872FCD03](#) [M8340109K4700GGD03](#) [M8340109M4701GCD03](#) [M8340109MA010GHD03](#)
[744C083101JTR](#) [EXB-U18240JX](#) [744C083270JTR](#) [745C102472JP](#) [745X101103JP](#) [MDP1603100KGE04](#) [770101223](#) [MNR04M0APJ471](#)
[MNR14E0APJ100](#) [MNR18E0APJ102](#) [MNR18E0APJ680](#) [ACAS06S0830339P100](#) [ACAS06S0830343P100](#) [ACAS06S0830344P100](#)
[RAVF164DJT68K0](#) [RM2012A-102/104-PBVW10](#) [RM2012A-502104-PBVW10](#) [NRSN04I4J220TRF](#) [NRSN06I4J330TRF](#)
[NRSNA4I4J330TRF](#) [8B472TR4](#) [ACAS06S0830341P100](#) [ACAS06S0830342P100](#) [ACAS06S0830345P100](#) [EXB-18N390JX](#)
[CSC09A014K70JEK](#) [M8340105K1502GGD03](#) [M8340105K8251FGD03](#) [M8340107K3402FCD03](#) [M8340108K1000GGD03](#)
[M8340108K2001FCD03](#) [M8340108K3901GGD03](#) [M8340108K5111FGD03](#) [M8340108K6201GGD03](#) [M8340109K2002GCD03](#)