



**Thick Film Chip Resistor Arrays  
Thick Film Chip Resistor Networks  
(Lead-Free for CN Series Standard)**

Document No.	TCN-XX0S0010
Revise Date	2011/06/24
page number	1 / 12

**1. Scope :**

This specification applies for the CN series of thick film chip resistor arrays & chip resistor networks made by TA-I.

**2. Construction , Dimensions , Schematic :**

**2.1 Construction :**

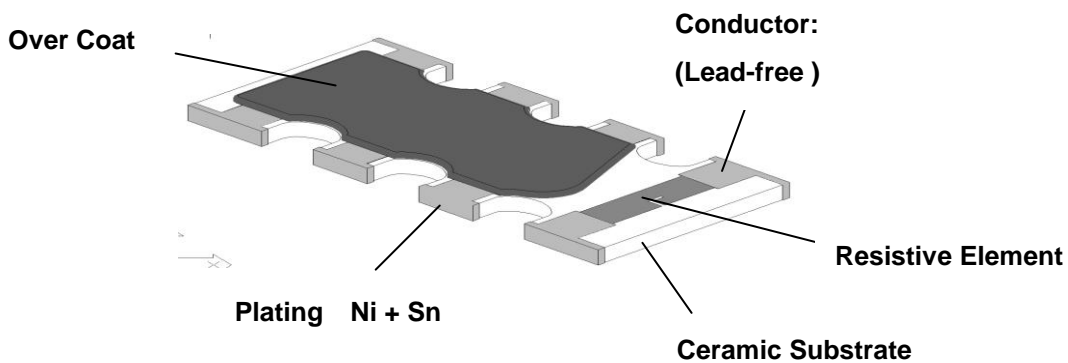

**2.1.1 Chip Resistor Arrays :**

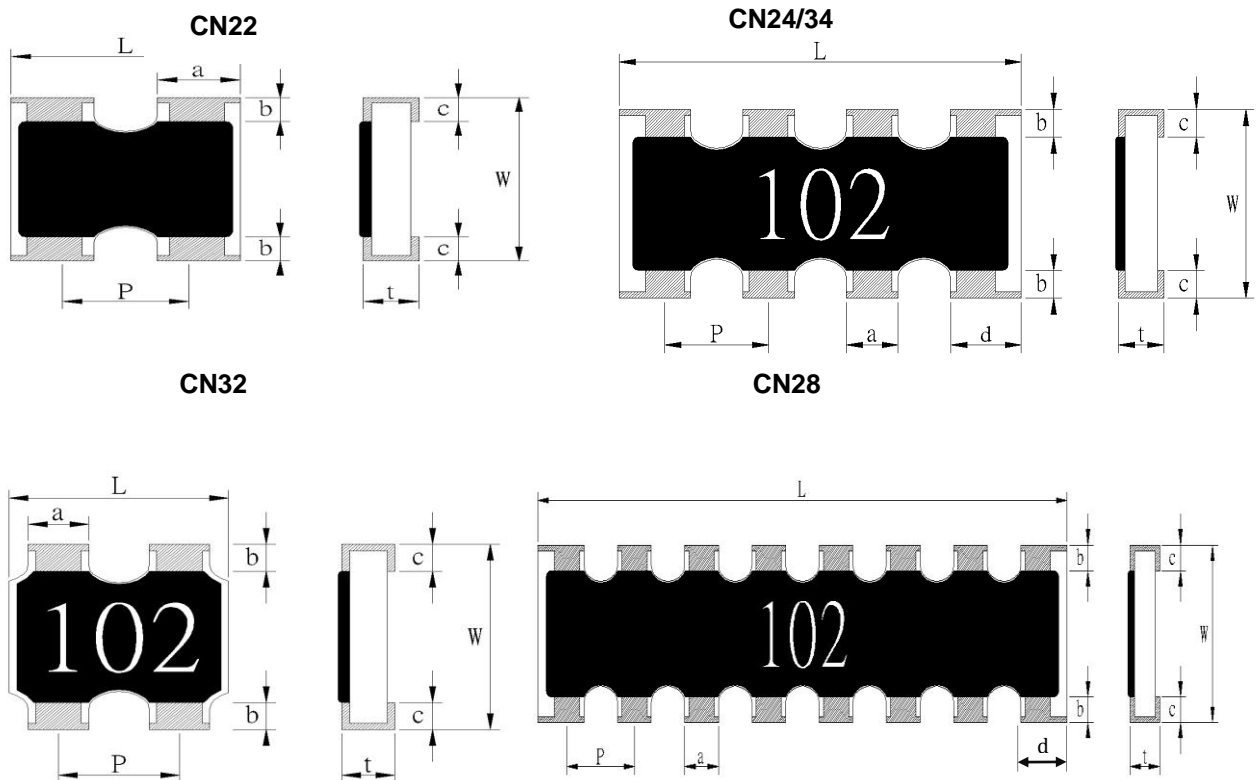



**Thick Film Chip Resistor Arrays**  
**Thick Film Chip Resistor Networks**  
**(Lead-Free for CN Series Standard)**

Document No.	TCN-XX0S0010
Revise Date	2011/06/24
page number	2 / 12

**2.1.2 Chip Resistor Networks**

**CN35**

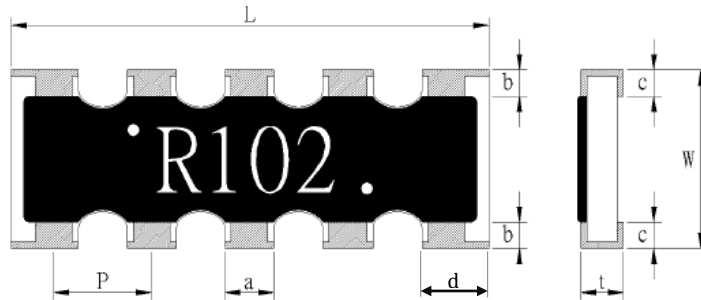

**2.2 Dimension :**

UNIT: mm

Type	L	W	t	P	a	b	c	d
CN22	1.0 ± 0.1	1.0 ± 0.1	0.35 ± 0.1	0.65 ± 0.1	0.33 ± 0.1	0.15 ± 0.1	0.25 ± 0.1	-----
CN24	2.0 ± 0.1	1.0 ± 0.1	0.4 ± 0.1	0.5 ± 0.05	0.3 ± 0.1	0.15 ± 0.1	0.25 ± 0.1	0.4±0.1
CN28	4.0 ± 0.2	1.6 ± 0.15	0.4 ± 0.1			0.25 ± 0.1		
CN32	1.6 ± 0.15	1.6 ± 0.15	0.45 ± 0.1	0.76 ± 0.1	0.45 ± 0.1	0.3 ± 0.2	0.3 ± 0.2	-----
CN34	3.2 ± 0.2	1.6 ± 0.15	0.5 ± 0.1	0.8 ± 0.05	0.45 ± 0.1	0.3 ± 0.2	0.3 ± 0.2	0.6±0.1
CN35				0.64 ± 0.05	0.35 ± 0.1			0.5±0.1

**2.3 Schematic :**

**CN35**

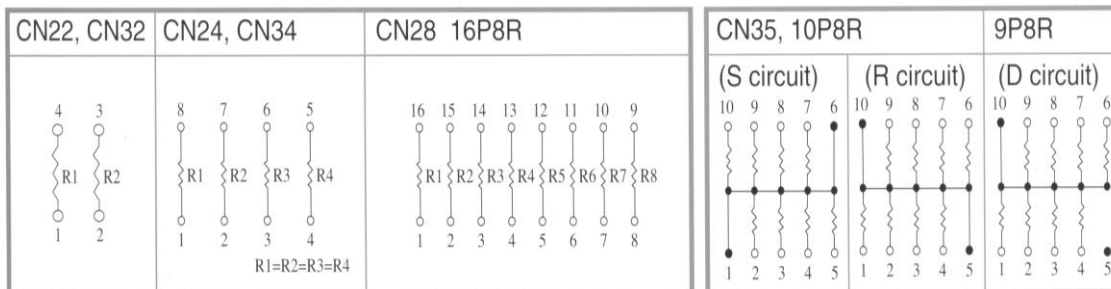
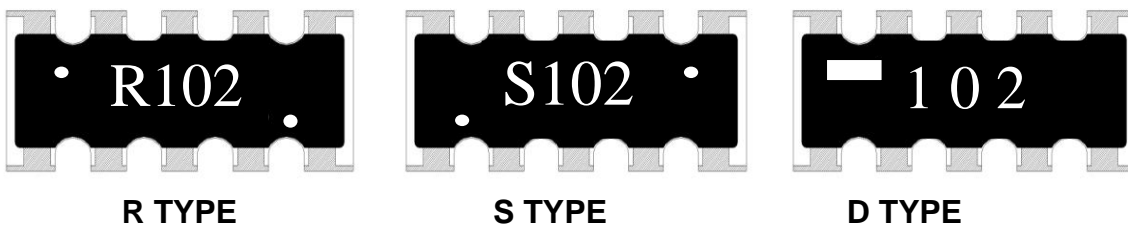



**Thick Film Chip Resistor Arrays**  
**Thick Film Chip Resistor Networks**  
**(Lead-Free for CN Series Standard)**

Document No.	TCN-XX0S0010
Revise Date	2011/06/24
page number	3 / 12

**3. Type Designation:**

**3.1 Chip Resistor Arrays**

**CN**

**34**

**J**

**TN**

**103**

Product Code  
CN : Chip Resistor Array

size  
Power Rating

Tolerance

Packaging

Nominal  
Resistance

<p>22-0402*2 24-0402*4 28-0402*8 32-0603*2 34-0603*4 35-0603*5</p>	<p>J-±5% G-±2% F-±1%</p>	<p>T- Paper Tape</p> <hr/> <p>N : Lead-free</p>	<p>3 digits E.G. : (E-24) 103 = 10KΩ 5R6 = 5.6Ω</p> <p>4 digits E.G. : (E-96) 1540 = 154Ω 43R2 = 43.2Ω</p>
--	----------------------------------	---	--

**3.2 Chip Resistor Networks**

**CN**

**35**

**J**

**TN**

**R**

**103**

Product Code  
CN : Chip Resistor Array

Size  
Power Rating

Tolerance

Packaging

Circuit

Resistance value

<p>35-0603*5</p>	<p>J-±5%</p>	<p>T-Paper tape</p> <hr/> <p>+N : Lead-Free</p>	<p>R-10P8R 5.10 com s-10P8R 1.6 com D-9P8R 10 com</p>	<p>3 digits E.G. : (E-24)103 = 10KΩ</p>
------------------	--------------	---	---	---

**Note :**

TN : Lead-Free products packaged by paper tape



**Thick Film Chip Resistor Arrays**  
**Thick Film Chip Resistor Networks**  
**(Lead-Free for CN Series Standard)**

Document No.	TCN-XX0S0010
Revise Date	2011/06/24
page number	4 /12

**4. Ratings & Characteristics :**

Type	Power Rating at 70°C	Rating Voltage	Max. Working Voltage	Max. Over Load Voltage	Operating Temp. (°C)	Resistance Tolerance (%)	Resistance Range (Ω)	Temp Co-efficient PPM/°C
CN22	1/16W	Refer 4.2	25V	50V	-55 ∩ +125°C	±5%	10Ω~1MΩ	±250
CN24								
CN28			50V	100V		±2%	10Ω~1MΩ	±200
CN32								
CN34			50V	100V		±1%	56Ω~100kΩ	±200
CN35								
CN34			50V	100V		±5%	3.0Ω~9.1Ω	±400
CN32								
CN22			25V	50V				±500
CN24								

0Ω THICK FILE CHIP RESISTOR ARRAYS			
Type	Rate Current	Max Overload Current	Resistance Range
CN Series	1A	2.5A	50mΩ MAX

**4.1 Derating Curve :**

For resistors operated at ambient temperature over 70°C , power rating shall be derated in accordance with figure 1.

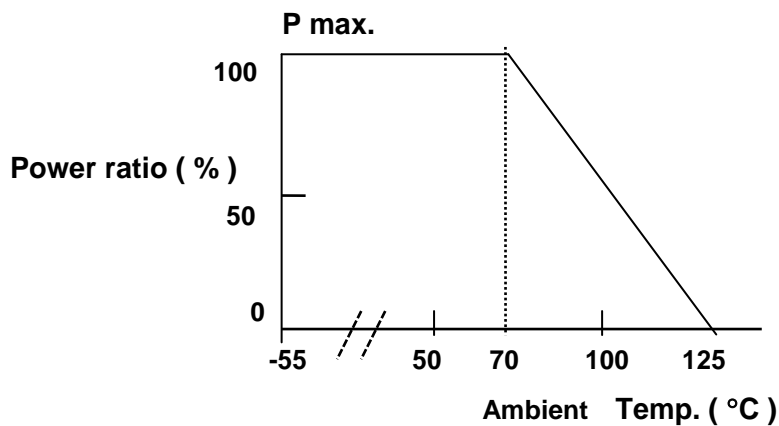

Figure 1

**4.2 Rated Voltage:**

The rated voltage is calculated by the following formula:

$$E = \sqrt{P * R}$$

E=Rated Voltage(V)  
P=Rated Power(W)  
R=Resistance Value(Ω)

E.G. : What is CN34JTN102 the rated voltage ?

CN34JTN102 P:1/16W ; R:102 = 1KΩ = 1000Ω

$$E = \sqrt{0.0625(W) * 1000(\Omega)} = 7.9 (V)$$



**Thick Film Chip Resistor Arrays**  
**Thick Film Chip Resistor Networks**  
**(Lead-Free for CN Series Standard)**

Document No.	TCN-XX0S0010
Revise Date	2011/06/24
page number	5 / 12

**5. Reliability Tests:**

Test Items	Reference standard	Condition of Test	Test Limits ( $\Delta R$ )
Temperature Coefficient of Resistance	IEC60115-1-4.8 JIS-C5201-4.8	-55~ +125 °C	Refer 4.0
Short Time Overload	IEC60115-1-4.13 JIS-C5201-4.13	2.5 X rated voltage for 5 sec	$\pm(2.0\%+0.1\Omega)$ 0 $\Omega$ : 50 m $\Omega$ or less
Intermittent Overload	IEC60115-1-4.39 JIS-C5201-4.39	2.5X rated voltage or Max Overloading Voltage , 1 sec "ON" 25 sec "OFF" , 10000 cycles	$\pm(5.0\%+0.1\Omega)$ 0 $\Omega$ : 50m $\Omega$ or less
Load Life	IEC60115-1-4.25.1 JIS-C5201-4.25.1	1000 hours at rated voltage , 70°C , 1.5hours "ON" , 0.5hour "OFF"	1%: $\pm(1.0\%+0.05\Omega)$ 5%: $\pm(3.0\%+0.1\Omega)$ 0 $\Omega$ :100 m $\Omega$ or less
Load Life with Humidity	IEC60115-1-4.24 JIS-C5201-4.24	1000 hours at rated voltage , 40 $\pm$ 2°C , 90~95% RH 1.5hours "ON" , 0.5hour "OFF"	1%: $\pm(1.0\%+0.05\Omega)$ 5%: $\pm(3.0\%+0.1\Omega)$ 0 $\Omega$ :100 m $\Omega$ or less
Rapid Change of Temperature	IEC60115-1-4.19 JIS-C5201-4.19	-55°C (30 min. ) / +155 °C (30 min. ) 5 cycles	1%: $\pm(0.5\%+0.05\Omega)$ 5%: $\pm(1.0\%+0.05\Omega)$ 0 $\Omega$ :50 m $\Omega$ or less
Solderability	IEC60115-1-4.17 JIS-C5201-4.17	245 $\pm$ 5°C solder, 2 $\pm$ 0.5 sec dwell. Solder : Sn96.5 / Ag3.0 / Cu0.5	At least 95% of surface area of electrode shall be covered with new solder.
Core body	IEC60115-1-4.15 JIS-C5201-4.15	Pressure 1.0 kgf a R0.5 pressure rod for 10 sec	Without mechanical damage such as breaks. Electrical characteristics shall be satisfied
Dielectric Withstanding Voltage (Voltage Proof)	IEC60115-1-4.7 JIS-C5201-4.7	Applying voltage 100V for 1 minute.	No abnormalities such as flashover, burning dielectric breakdown shall appear.
Resistance to Solder Heat	IEC60115-1-4.18 JIS-C5201-4.18	270 $\pm$ 5°C solder , 10 $\pm$ 1 sec dwell .	0.5%,1%: $\pm(1.0\%+0.05\Omega)$ 2%,5%: $\pm(2.0\%+0.1\Omega)$ 0 $\Omega$ : 50m $\Omega$ or less

Note\* : RCWV : Rated continuous working voltage .



**Thick Film Chip Resistor Arrays**  
**Thick Film Chip Resistor Networks**  
**(Lead-Free for CN Series Standard)**

Document No.	TCN-XX0S0010
Revise Date	2011/06/24
page number	6 /12

**6. Marking**

**6.1 ±5%(E24)**

Resistance value is expressed by 3 digits, the first two digits represent the significant figures of nominal resistance value in  $\Omega$ , and the third digit represents exponent for base of 10.

E.G.  $472 = 47 \times 10^2 = 4700 \Omega = 4.7K\Omega$

**6.2 ±1% (E96)**

Resistance value is expressed by 3 digits, the first three digits represent the significant figures of nominal resistance value in  $\Omega$ , and the fourth digit represents exponent for base of 10.

E.G.  $4701 = 470 \times 10^1 = 4700 \Omega = 4.7k\Omega$

**6.3 No Marking for CN22**

**7. Taping & Reel**

**7.1 Taping Dimensions**

**7.1.1 2 mm pitch paper**

UNIT: mm

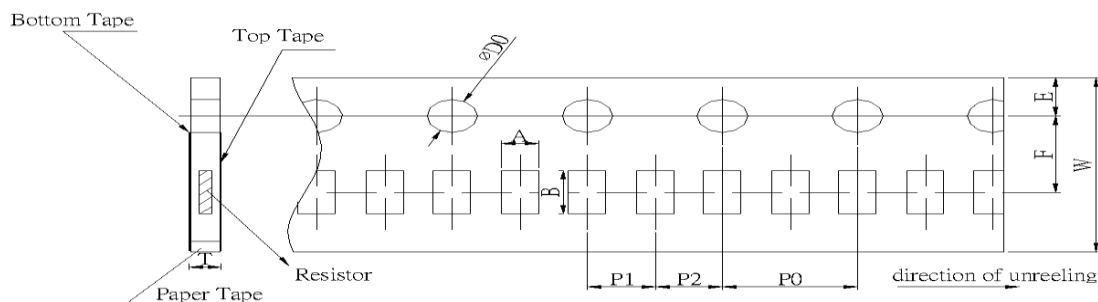

Type	A	B	W	F	E	P1	P2	P0	$\phi D0$	T0
CN22	1.2±0.15	1.2±0.1	8.0±0.2	3.5±0.05	1.75±0.1	2.0±0.1	2.0±0.05	4.0±0.1	1.5	+0.1
CN24		2.2±0.2								-0



**Thick Film Chip Resistor Arrays**  
**Thick Film Chip Resistor Networks**  
**(Lead-Free for CN Series Standard)**

Document No.	TCN-XX0S0010
Revise Date	2011/06/24
page number	7 / 12

**7.1.2 4 mm pitch paper**

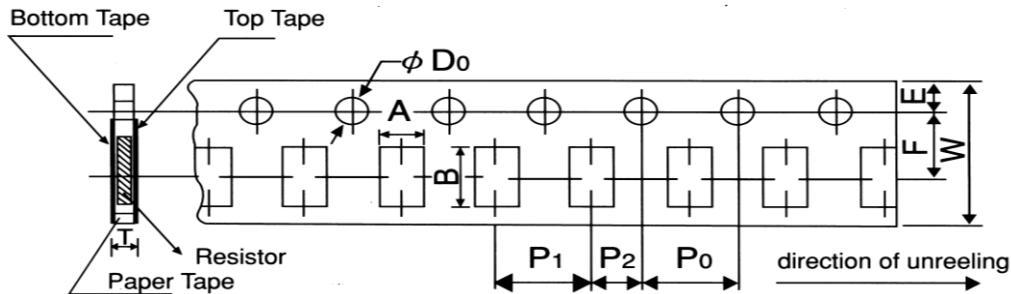

UNIT: mm

Type	A	B	W	F	E	P1	P2	P0	$\phi D0$	T
CN28	1.9±0.2	4.3±0.2	8.0±0.2	3.5±0.05	1.75±0.1	4.0±0.1	2.0±0.05	4.0±0.1	1.5	0.84±0.1
CN32	1.8±0.2	1.8±0.2								
CN34, 35	2.0±0.15	3.6±0.2								

Package Type	Paper Tape			
	4 mm pitch		2 mm pitch	
	178mm/R	250mm/R	178mm/R	250mm/R
CN22			10000	20000
CN24			10000	20000
CN28	5000			
CN32	5000			
CN34	5000	10000		
CN35	5000	10000		

**7.2 Reel Specifications**

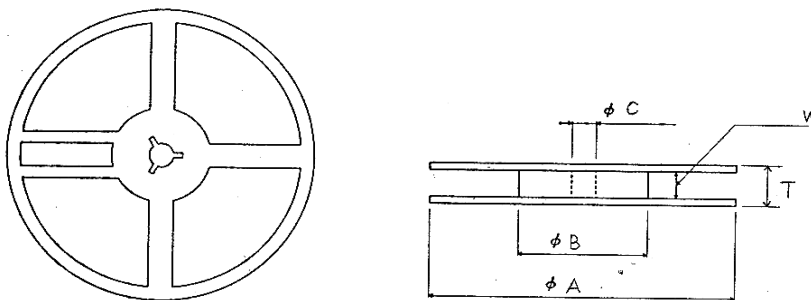

UNIT: mm

Type	$\phi A$	$\phi B$	$\phi C$	W	T
CN22/24/28 CN32/34/35	178.0 ± 2.0	60.0 ± 1.0	13.0 ± 1.0	9.0 ± 1.0	11.5 ± 1.0



**Thick Film Chip Resistor Arrays**  
**Thick Film Chip Resistor Networks**  
**(Lead-Free for CN Series Standard)**

Document No.	TCN-XX0S0010
Revise Date	2011/06/24
page number	8 / 12

**7.3 Peel off Strength:**

Peel-off force of paper and blister tape is in accordance with "JIS-C5202"  
that is , 0.1 to 0.7 N at a peel-off speed of 300 mm / minute.

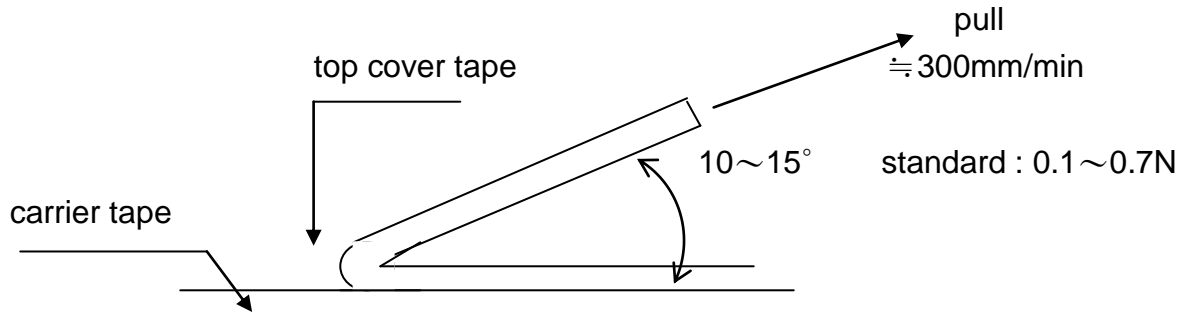

**8. Label**

**8.1 Manufacture Label :**

**8.1.1 Chip Resistor Array**

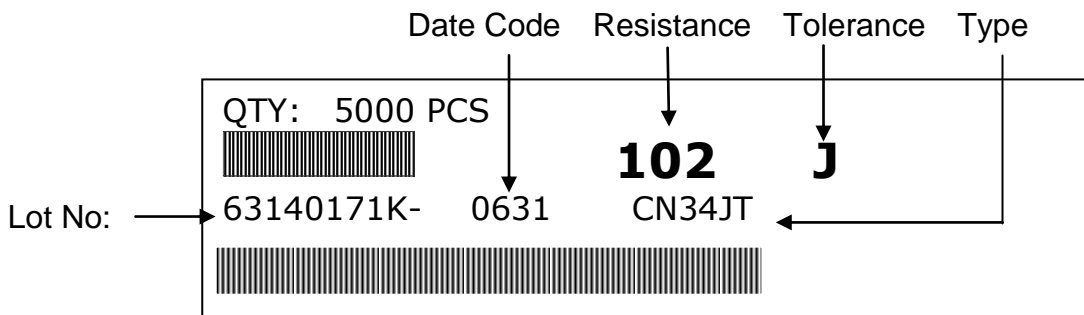

**8.1.2 Chip Resistor Networks**

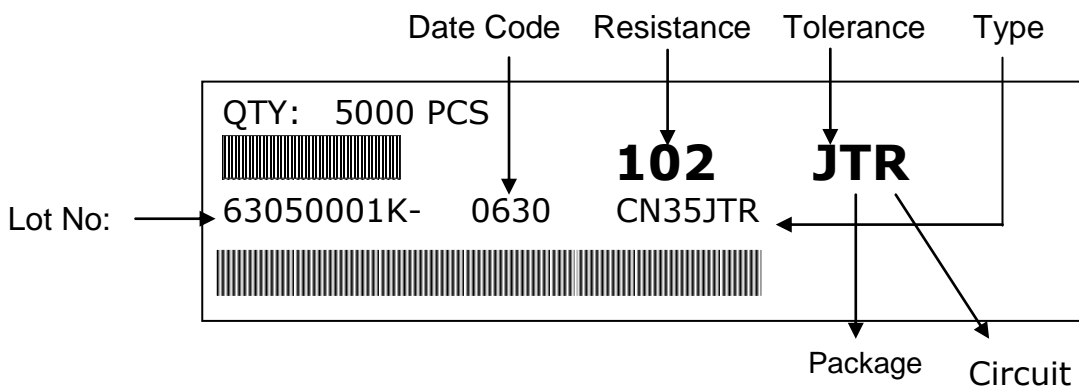





**Thick Film Chip Resistor Arrays**  
**Thick Film Chip Resistor Networks**  
**(Lead-Free for CN Series Standard)**

Document No.	TCN-XX0S0010
Revise Date	2011/06/24
page number	9 / 12

**8.2. Customer Label ( By customer request ):**

**8.2.1 Chip Resistor Array**

Lead-Free Product

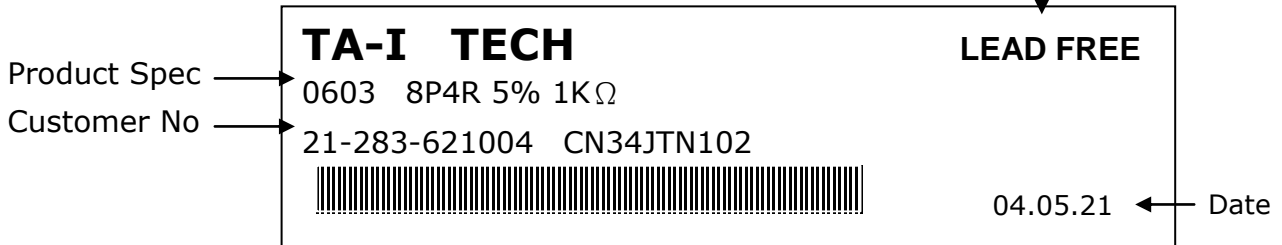

**8.2.2 Chip Resistor Networks**

Lead-Free Product

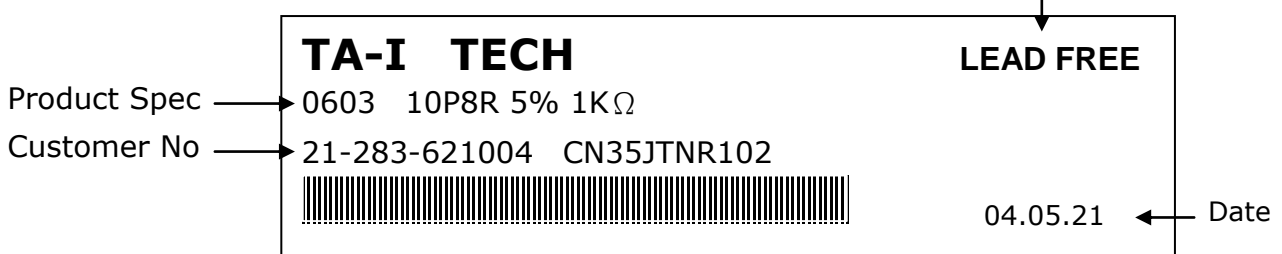

**9. Recommended land patterns :**

**9.1 CN22,CN32,CN34,CN35**

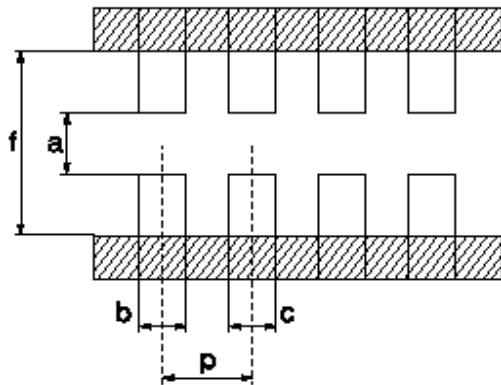

Land pattern		Dimension ( mm )				
Type	Size	a	b	c	p	f
CN	22	0.5	0.35~0.4	0.35~0.4	0.65	1.4~1.5
CN	32	0.7~0.9	0.4~0.5	0.4~0.5	0.8	2.2~2.6
CN	34	0.7~0.9	0.4~0.5	0.4~0.5	0.8	2.2~2.6
CN	35	0.7~0.9	0.4~0.5	0.3~0.4	0.64	2.2~2.6



**Thick Film Chip Resistor Arrays  
Thick Film Chip Resistor Networks  
(Lead-Free for CN Series Standard)**

Document No.	TCN-XX0S0010
Revise Date	2011/06/24
page number	10 / 12

**9.2 CN24 ,CN28**

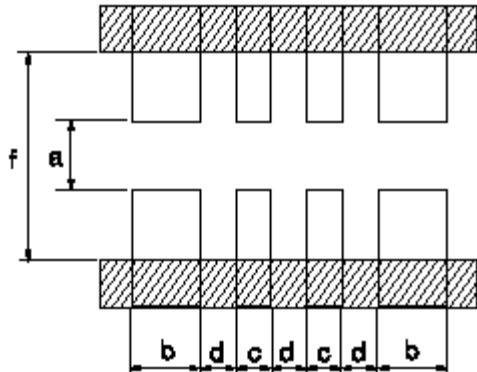

Land pattern		Dimension ( mm )				
Type	Size	a	b	c	d	f
CN	24	0.4	0.525	0.25	0.25	1.4
CN	28	1.0	0.425	0.25	0.25	2.0

**10. Recommend IR – Reflow profile : (solder : Sn96.5 / Ag3 / Cu0.5)**

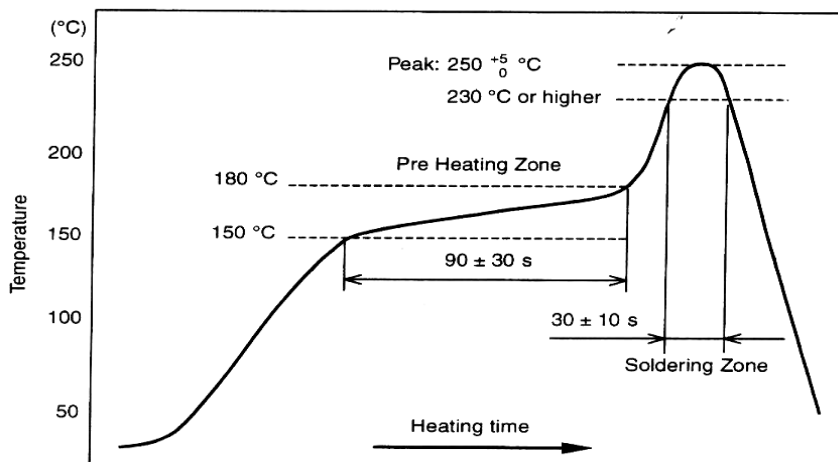

Peak :  $250 \begin{matrix} +5 \\ -0 \end{matrix} \text{ } ^\circ\text{C}$  , 5 sec

Pre – heat Zone : 150 to 180  $^\circ\text{C}$  , 90  $\pm$  30 sec

Soldering Zone : 230 $^\circ\text{C}$  or higher , 30  $\pm$  10 sec



**Thick Film Chip Resistor Arrays  
Thick Film Chip Resistor Networks  
(Lead-Free for CN Series Standard)**

Document No.	TCN-XX0S001O
Revise Date	2011/06/24
page number	11 /12

**11. Storage Conditions:**

Temperature : 5 to 35 °C

Related Humidity :40 to 75% RH

**12. Shelf Life :**

2 Years from manufacturing date.

**13. ECN :**

Engineering Change Notice: The customer will be informed with ECN if there is significant modification on the characteristics and materials described in Approval Sheet.

**14. Manufacturing Country & City :**

TA-I TECHNOLOGY CO., LTD. ( Taiwan– Tao Yuan )

Tel: 886-3-3246169 Fax : 886-3-3246167

**Associated companies :**

(1) FORTUNE TASK RESISTOR FACTORY ( China – Dongguan )

Tel : 86-769-8339-4790~3 Fax : 86-769-8339-4794

(2) TA-I TECHNOLOGY (DONGGUAN ) CO., LTD. ( China –Dongguan )

Tel : 86-769-8339-4790~3 Fax : 86-769-8339-4794

(3) TA-I TECHNOLOGY ( SU ZHOU ) CO., LTD. ( China – Su Zhou)

Tel :86- 512-63457879 Fax : 86-512-63457869

(4) TAI OHM ELECTRONICS ( M ) SDN. BHD. ( Malaysia – Pulaupinang )

Tel :604- 3900480 Fax : 604-3901481

(5) P.T.TAI ELECTRONICS Indonesia ( Indonesia – Jakarta )

Tel :002-62-21-44820254 Fax : 002-62-21-44820256



**Thick Film Chip Resistor Arrays**  
**Thick Film Chip Resistor Networks**  
**(Lead-Free for CN Series Standard)**

Document No.	TCN-XX0S0010
Revise Date	2011/06/24
page number	12 /12

**Revise record**

Date	Content	Owner																	
Nov.25.2005	2. Construction , Dimensions , Schematic : Adding to "R", "S", "D" type 4. Ratings & Characteristics : Adding Rating Voltage	Hank Liu																	
Dec.12.2005	5. Reliability Tests: Intermittent Overload : 3X rate power changed 2.5X rated voltage Whisker : -35±5°C / 125±5°C , Keep 7 min changed -55°C (30 min.) / +155°C (30 min. )	Hank Liu																	
Jul.06.2006	2.1 Conductor : Adding to (Lead-free or with lead) 5. Reliability Tests: Temperature Coefficient of Resistance : Refer 5.0 changed Refer4.0 8.1 Manufacture label : Series number 3 codes changed to 4 codes 14. Manufacturing Country & City: Adding TA-I TECHNOLOGY (DONGGUAN ) CO., LTD	Vincent																	
Nov.13.2006	4. Ratings & Characteristics : Adding resistance range 5.1 Ω – 9.1 Ω for CN34 type 5% product .	Vincent																	
Mar.28.2007	2.2 Dimension CN28 b : from 0.15 ± 0.1 revise to 0.25 ± 0.1 CN35 p : from 0.6 ± 0.05 revise to 0.64 ± 0.05	Vincent																	
May.31.2007	<b>4. Ratings &amp; Characteristics :</b> CN35 Resistance Range (Ω) : 10 Ω~1MΩ changed to <b>56Ω~1MΩ</b>	Vincent																	
Aug.23.2007	Adding resistance range <table border="1" style="margin-left: 20px;"> <tr> <td>CN32</td> <td rowspan="3">1/16W</td> <td rowspan="3">Refer 4.2</td> <td>50V</td> <td>100V</td> <td rowspan="3">-55 ∫ +125°C</td> <td rowspan="3">±5%</td> <td rowspan="3">3.0Ω~9.1Ω</td> <td>±400</td> </tr> <tr> <td>CN22</td> <td>25V</td> <td>50V</td> <td>±500</td> </tr> <tr> <td>CN24</td> <td></td> <td></td> <td></td> </tr> </table>	CN32	1/16W	Refer 4.2	50V	100V	-55 ∫ +125°C	±5%	3.0Ω~9.1Ω	±400	CN22	25V	50V	±500	CN24				Vincent
CN32	1/16W	Refer 4.2			50V	100V				-55 ∫ +125°C	±5%	3.0Ω~9.1Ω	±400						
CN22					25V	50V							±500						
CN24																			
June.19.2008	1. Reliability test : To delete special customer's standard: SS-00254 standard. 2. Resistance range of CN35 To correct resistance range from 1MΩ 56~1MΩ to 56~100KΩ.	Vincent																	
March.10.2011	Reliability test : Reference standard from JIS-5202 change to IEC60115 & JIS-C5201	Kate																	
June 27.2011	Adding Dimension "d" CN24/CN28: 0.4 ± 0.1mm CN34: 0.6 ± 0.1mm CN35: 0.5 ± 0.1mm	Kate																	

## X-ON Electronics

Largest Supplier of Electrical and Electronic Components

*Click to view similar products for [Resistor Networks & Arrays](#) category:*

*Click to view products by [TA-I Tech](#) manufacturer:*

Other Similar products are found below :

[CSC06A0122K0GEJ](#) [CSC08A01470KGEK](#) [M8340105M1202GGD03](#) [M8340105M4700JGD03](#) [M8340107K1471FGD03](#)  
[M8340108K2402GGD03](#) [M8340108K3240FGD03](#) [M8340108K4991FGD03](#) [M8340108K6192FGD03](#) [M8340108K6202GGD03](#)  
[M8340109MA010GHD03](#) [744C083101JTR](#) [EXB-U18240JX](#) [744C083270JTR](#) [745C102472JP](#) [745X101103JP](#) [MDP1603100KGE04](#)  
[770101223](#) [MNR04M0APJ471](#) [MNR14E0APJ100](#) [MNR18E0APJ102](#) [MNR18E0APJ680](#) [ACAS06S0830339P100](#) [ACAS06S0830343P100](#)  
[ACAS06S0830344P100](#) [RAVF164DJT68K0](#) [RM2012A-102/104-PBVW10](#) [RM2012A-102503-PBVW10](#) [RM2012A-502104-PBVW10](#)  
[NRSN04I4J220TRF](#) [NRSN06I4J330TRF](#) [NRSNA4I4J330TRF](#) [8B472TR4](#) [ACAS06S0830341P100](#) [ACAS06S0830342P100](#)  
[ACAS06S0830345P100](#) [EXB-18N390JX](#) [EXB-V4N100JV](#) [CSC09A014K70JEK](#) [M8340105K1502GGD03](#) [M8340105K8251FGD03](#)  
[M8340105M1001JCD03](#) [M8340105M1002GCD03](#) [M8340106K4701GGD03](#) [M8340107K1004GGD03](#) [M8340107K3402FCD03](#)  
[M8340108K1000FGD03](#) [M8340108K1000GGD03](#) [M8340108K1202GGD03](#) [M8340108K2001FCD03](#)