

### 1. Scope :

This specification applies for the RL series of alloy film chip resistors made by TA-I.

### 2. Construction :

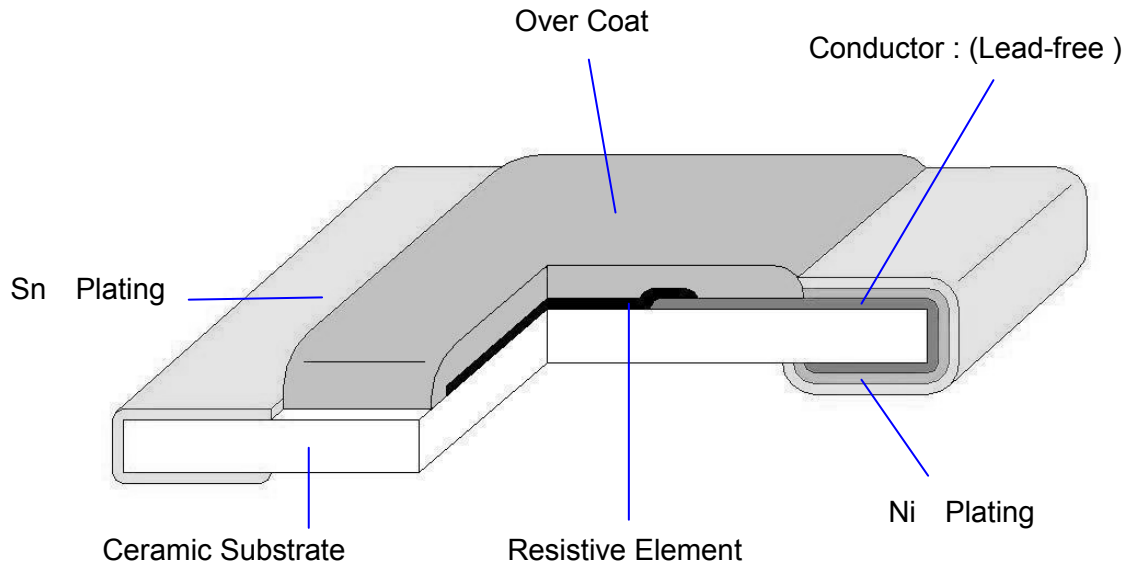

### 3. Type Designation :

**RL**

Product Code  
RL : Chip Resistor

**10**

Size  
Power Rating

**F**

Tolerance

**TN**

Packaging

**R100**

Nominal  
Resistance

04-0402(1005) 1/16W  
06-0603(1608) 1/8W  
10-0805(2012) 1/4W  
12-1206(3216) 1/2W  
20-2010(5025) 3/4W  
25-2512(6432) 1W

J-  $\pm 5\%$   
G-  $\pm 2\%$   
F-  $\pm 1\%$

T-Paper Tape  
E-Embossed Tape  
N-Lead Free

3 Digits e.g.,5%  
(E24) R10=0.1 $\Omega$   
4 Digits e.g.,1%  
(E96) R100=0.1 $\Omega$

### 4. Dimensions :

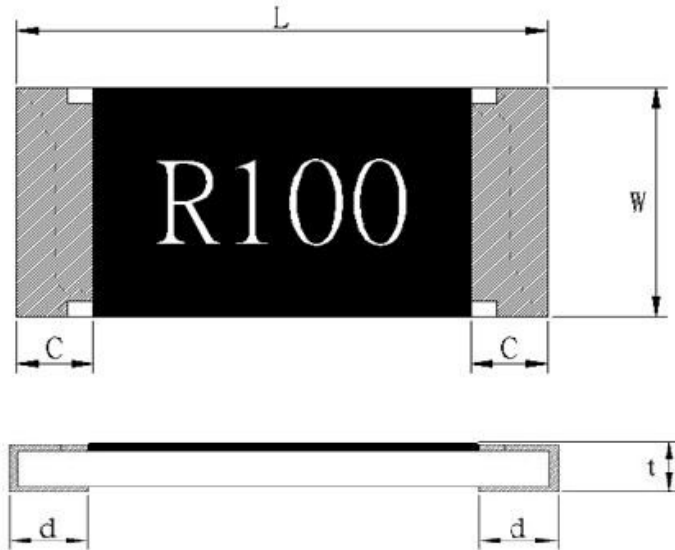

UNIT: mm

Type	L	W	C	d	t
RL04	1.00 <sup>+0.10</sup> / <sub>-0.05</sub>	0.50 ±0.05	0.20 ±0.10	0.25 ±0.10	0.35 ±0.05
RL06	1.60 ±0.10	0.80 ±0.10	0.30 ±0.20	0.35 ±0.20	0.45 ±0.10
RL10	2.00 ±0.10	1.25 ±0.10	0.40 ±0.20	0.35 ±0.20	0.50 ±0.10
RL12	3.10 ±0.20	1.55 ±0.10	0.50 ±0.30	0.40 ±0.20	0.55 ±0.10
RL20	5.00 ±0.20	2.50 ±0.20	0.60 ±0.30	0.50 ±0.25	0.55 ±0.10
RL25	6.30 ±0.20	3.20 ±0.20	0.60 ±0.30	0.50 ±0.25	0.55 ±0.10

### 5. Electrical characteristics :

Characteristics	Feature						Measurement Method
	RL04	RL06	RL10	RL12	RL20	RL25	
Power Ratings (W)	1/16W	1/8W	1/4W	1/2W	3/4W	1W	JIS Code 3A / JIS Code 3D
Resistance Value (mΩ)	100 ~ 910						Refer to JIS C 5201-1-4.5
T.C.R ( ppm / °C )	100~500mΩ: ±300 501~910mΩ: ±200	±200					Refer to JIS C 5201-1-4.8
Operation Temperature Range(°C)	-55 ~ +155						
Resistance Tolerance (%)	± 1%, ± 2%, ± 5%						JIS C 5201-1-4.2.5
Insulation Resistance (MΩ)	Over 100						Refer to JIS C 5201-1-4.6
Maximum Working Voltage (V)	$(P * R)^{1/2}$						

Note : Except for the above standardized products, we also provide the customized products.

### 5.1 Derating Curve :

For resistors operated at ambient temperature over 70°C , power rating shall be derated in accordance with figure 1.

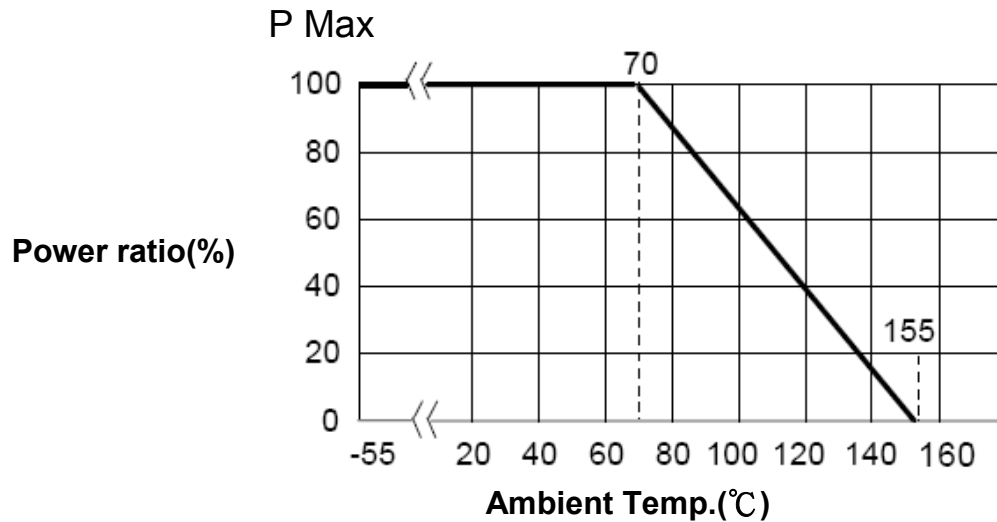

Figure 1

### 6. Reliability Test :

Test Item	Reference standard	Condition of Test	Test Limits
Temperature Coefficient of Resistance	IEC60115-1-4.8 JIS-C5201-1-4.8	-55 ~ +125°C	Refer to paragraph 5
Short Time Overload	IEC60115-1-4.13 JIS-C5201-1-4.13	2.5 X rated voltage, 5s	1%:± (1%+0.005 Ω ) 2%,5%:± (3%+0.005 Ω ) Remark: 0402±(2%+0.005 Ω )
Load Life	IEC60115-1-4.25.1 JIS-C5201-1-4.25.1	1000 hours at rated power , 70°C , 1.5hours "ON " , 0.5hour "OFF"	1%:± (1%+0.001 Ω ) 2%,5%:± (3%+0.001 Ω ) Remark: 0402±(3%+0.005 Ω )
Load Life with Humidity	IEC60115-1-4.24 JIS-C5201-1-4.24	1000 hours at rated power , 40 ± 2°C , 90~95% RH 1.5hours "ON " , 0.5hour "OFF"	1%:± (1%+0.001 Ω ) 2%,5%:± (3%+0.001 Ω ) Remark: 0402±(3%+0.005 Ω )
Rapid Change of Temperature	IEC60115-1-4.19 JIS-C5201-1-4.19	-55°C (30 min. ) / +155 °C(30 min.) 5 cycles	± 1%+0.005 Ω
Resistance to Soldering Heat	IEC60115-1-4.18 JIS-C5201-1-4.18	270 ± 5°C solder , 10 ± 1 sec dwell .	± 1%+0.005 Ω
Solderability	IEC60115-1-4.17 JIS-C5201-1-4.17	245±5°C solder, 2±0.5 sec dwell. Solder : Sn96.5 / Ag3.0 / Cu0.5	At least 95% of surface area of electrode shall be covered with new solder.
Robustness of Termination (Bending Strength)	IEC60115-1-4.33 JIS-C5201-1-4.33	3mm deflection 2mm deflection (RL20,25)	± 1%+0.005Ω
Resistance to Dry Heat	IEC60115-1-4.23.2 JIS-C5201-1-4.23.2	155 ± 5°C for 96 ± 4hrs	1%: ± (1%+0.005 Ω ) 2%,5%:± (2%+0.005 Ω )

Note\* :RCWV : Rated continuous working voltage .

### 7. Marking :

#### 7.1 Type : 0805,1206,2010,2512

##### 7.1.1 E96: 1%

Resistance value is expressed by 4 digits, the first "R" means decimal point and the other digits represent for the normal resistance in  $\Omega$ .

e.g., R100 =100 m $\Omega$

##### 7.1.2 E24: 2%,5%

Resistance value is expressed by 3 digits, the first "R" means decimal point and the other digits represent for the normal resistance in  $\Omega$ .

e.g., R10 =100 m $\Omega$

#### 7.2 Type : 0603

##### 7.2.1 E96: 1%

When the marking space is too small in such small-sized resistors as RL06, the marking can not made by 4 digits and may be made by two digits combined with one English capital.

Significant figures of nominal resistance

Symbol	E24	E96
01	10	100
02	11	110
03	12	
04	13	130
05	15	150
06	16	
07	18	
08	20	200
09	22	
10	24	
11	27	
12	30	
13	33	
14	36	
15	39	
16	43	
17	47	
18	51	
19	56	
20	62	
21	68	
22	75	750
23	82	
24	91	

#### Symbol for multipliers

Symbol	A	B	C	D	E	F	G	H	X	Y	Z
multipliers	10 <sup>0</sup>	10 <sup>1</sup>	10 <sup>2</sup>	10 <sup>3</sup>	10 <sup>4</sup>	10 <sup>5</sup>	10 <sup>6</sup>	10 <sup>7</sup>	10 <sup>-1</sup>	10 <sup>-2</sup>	10 <sup>-3</sup>

e.g., 01Z=100 ×10<sup>-3</sup>=100 m $\Omega$

#### Notes :

When the resistance value is not in the list of E96 , 3 digitals with underline in E-24 series is used as mark .

e.g., 0603 : 120m $\Omega$ , 1% Marking is 012

### 7.2.2 E24: 2%,5%

Resistance value is expressed by 3 digits, the first "0" means decimal point and the other digits represent for the normal resistance in  $\Omega$ .

e.g., 010 = 100 m $\Omega$

### 7.2 Type: 0402

RL04 : No Marking

## 8. Taping & Reel :

### 8.1 Taping Dimensions :

#### 8.1.1 4 mm pitch paper

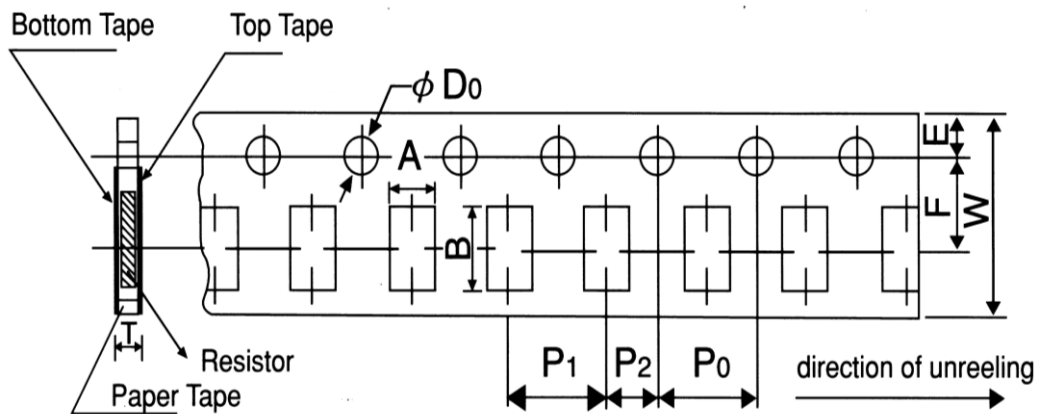

UNIT: mm

Packing	Type	A	B	W	F	E	P <sub>1</sub>	P <sub>2</sub>	P <sub>0</sub>	D <sub>0</sub>	T
Paper Tape	RL06	1.1 ±0.1	1.9 ±0.1	8.0±0.2	3.5±0.05	1.75±0.1	4.0±0.1	2.0±0.05	4.0±0.1	φ 1.5	0.64 ±0.1
	RL10	1.6 ±0.15	2.4 ±0.2								+0.1
	RL12	2.0 ±0.15	3.6 ±0.2								-0

### 8.1.2 2 mm pitch paper :



Packing	Type	A	B	W	F	E	P <sub>1</sub>	P <sub>2</sub>	P <sub>0</sub>	D <sub>0</sub>	T
Paper Tape	RL04	0.7±0.05	1.2±0.05	8.0 ±0.2	3.5±0.05	1.75±0.1	2.0 ±0.1	2.0 ±0.1	4.0 ±0.1	φ 1.5 +0.1 -0	0.45 ±0.1
	RL06	1.1 ±0.1	1.9 ±0.1	8.0 ±0.2	3.5±0.05	1.75±0.1	4.0 ±0.1	2.0 ±0.1	4.0 ±0.1	φ 1.5 +0.1 -0	0.64 ±0.1

### 8.1.3 4 mm pitch Emboss :

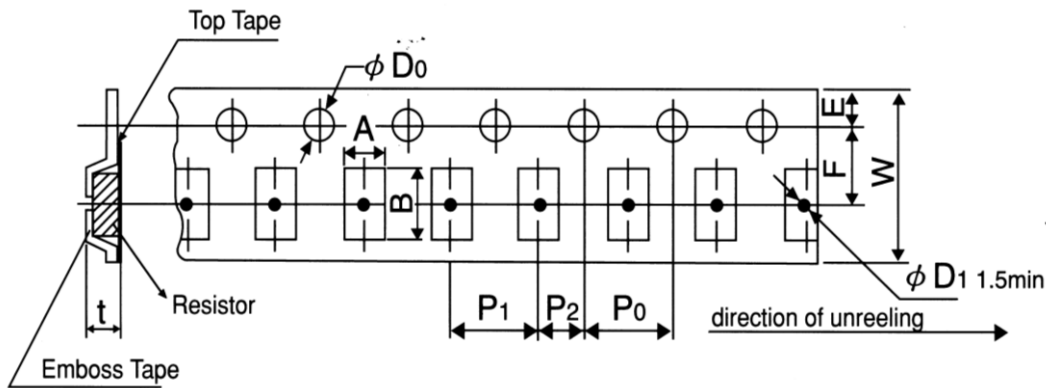

Packing	Type	A	B	W	F	E	P <sub>1</sub>	P <sub>2</sub>	P <sub>0</sub>	D <sub>0</sub>	T
Emboss	RL20	2.8 ±0.2	5.3 ±0.2	12.0±0.2	5.5±0.05	1.75±0.1	4.0±0.1	2.0±0.05	4.0±0.05	φ 1.5 +0.1 -0	0.85 ±0.15
	RL25	3.6 ±0.2	6.9 ±0.2								

Type Size		Paper Tape		Emboss Plastic Tape 4 mm pitch
		4 mm pitch	2 mm pitch	
		178mm/R	178mm/R	
RL	04		10000	
RL	06	5000	10000	
RL	10	5000		
RL	12	5000		
RL	20			4000
RL	25			4000

### 8.2 Reel Specifications :

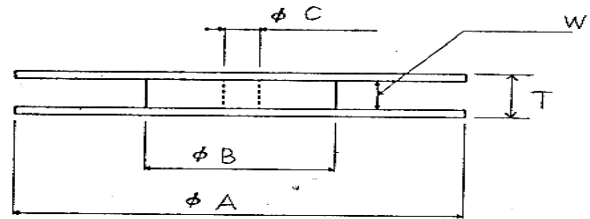
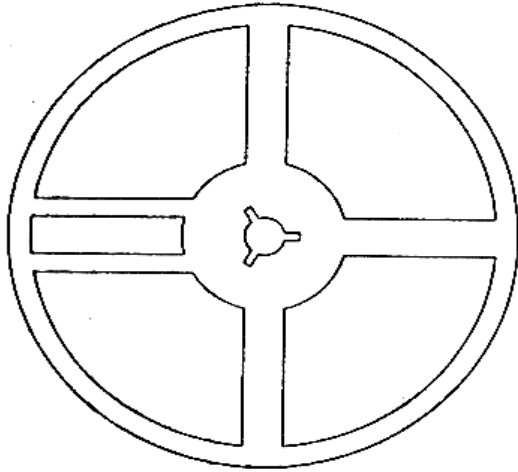

UNIT: mm

Series	$\phi A$	$\phi B$	$\phi C$	W	T
RL 04 / 06 / 10 / 12	$178 \pm 2.0$	$60.0 \pm 1.0$	$13.0 \pm 1.0$	$9.0 \pm 1.0$	$11.5 \pm 1.0$
RL 20 / 25				$13.0 \pm 1.0$	$15.5 \pm 1.0$

### 8.3 Peel – off force :

Peel – off force of paper and blister tape is in accordance with “JIS-C5202 ” that is , 0.1 to 0.7 N at a peel-off speed of 300 mm / minute.

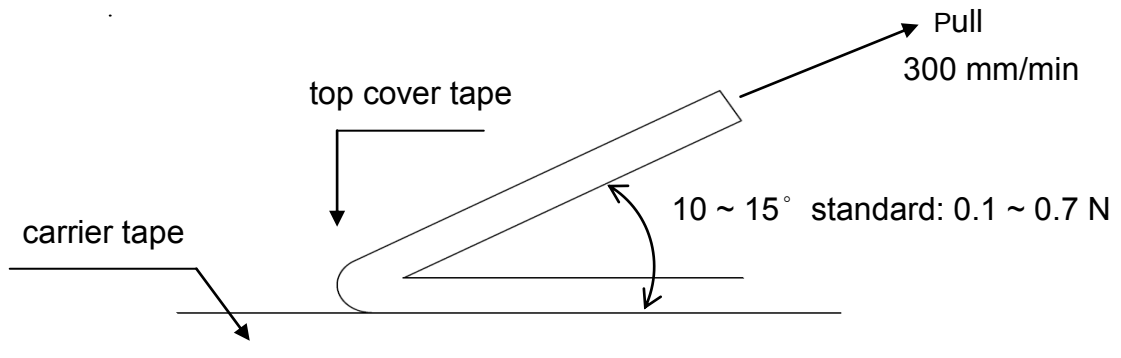

### 9. Label :

#### 9.1 Manufacture Label :

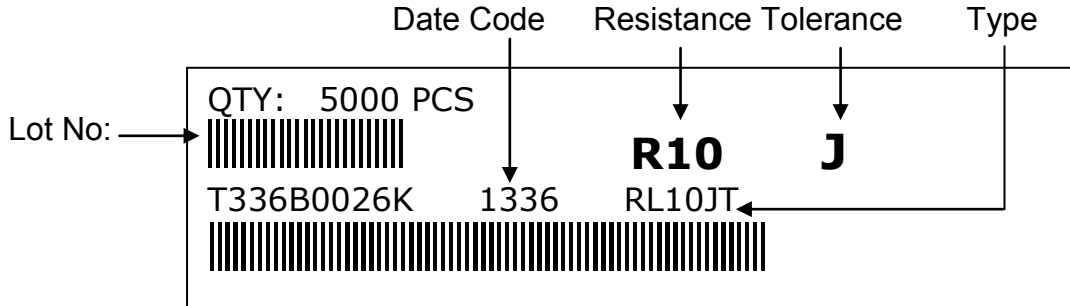

#### 9.2 Customer Label: ( By customer request ) :



### 10. Recommended land patterns :

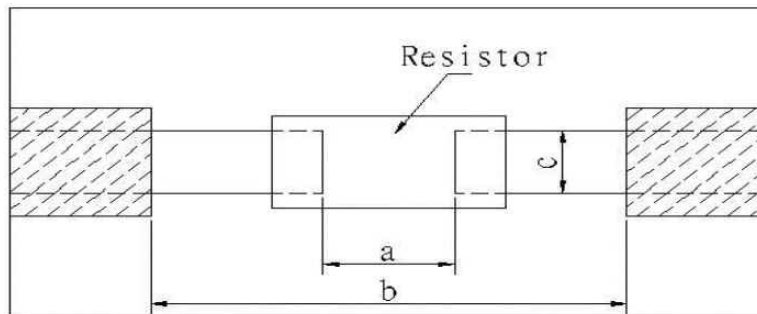

Type	Land pattern Size	Dimension ( mm )		
		a	b	c
RL	04(1005 )	0.5~0.6	1.4~1.6	0.4~0.6
RL	06 (0603 )	0.7~0.9	2.0~2.2	0.8~1.0
RL	10 (0805 )	1.0~1.4	3.2~3.8	0.9~1.4
RL	12 (1206 )	2.0~2.4	4.4~5.0	1.2~1.8
RL	20 (2010 )	3.3~3.7	5.7~6.5	2.3~3.5
RL	25 (2512 )	3.6~4.0	7.6~8.6	2.3~3.5



### 11. Recommend IR – Reflow profile : ( Lead-Free solder : Sn96.5 / Ag3 / Cu0.5 )

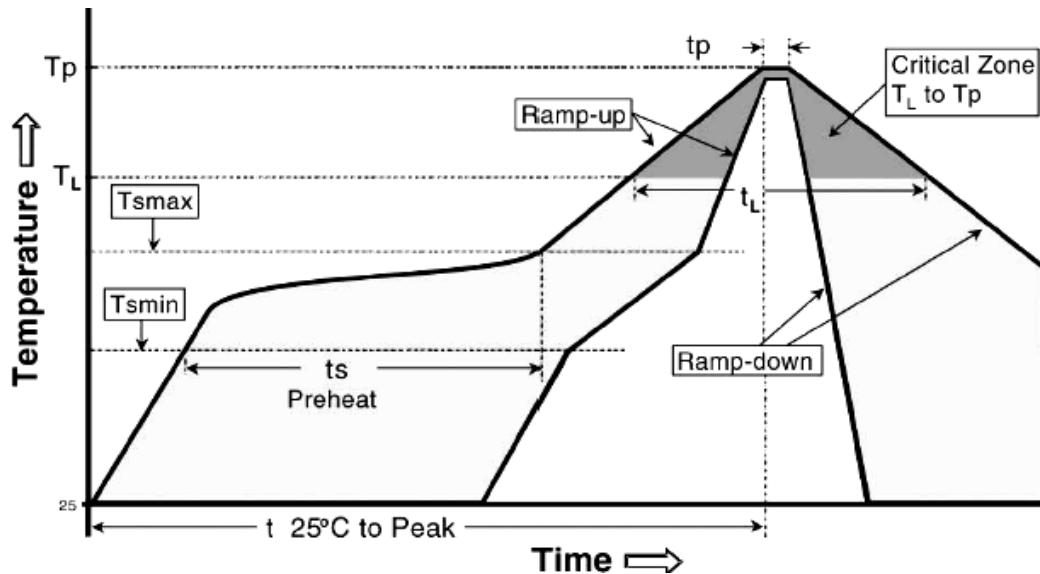

Profile Feature	Lead (Pb )-Free Assembly
Average ramp-up rate (T <sub>smax</sub> to T <sub>p</sub> )	3°C / second max.
Preheat - Temperature Min (T <sub>smin</sub> ) - Temperature Max (T <sub>smax</sub> ) - Time (T <sub>smin</sub> to T <sub>smax</sub> ) (ts)	150°C 200°C 60 -150 seconds
Time maintained above : - Temperature (T <sub>l</sub> ) - Time (t <sub>L</sub> )	217°C 60-120 seconds
Peak Temperature (T <sub>p</sub> )	260°C
Time within $\begin{matrix} +0 \\ -5 \end{matrix}$ °C of actual Peak Temperature (t <sub>p</sub> ) <sup>2</sup>	10 seconds
Ramp-down Rate	6°C/second max.
Time 25°C to Peak Temperature	8minutes max.

Allowed Re-flow times : 3 times

Remark : To avoid discoloration phenomena of chip on terminal electrodes, please use N2 Re-flow furnace .

### 12. Storage Conditions :

Temperature: 5°C~35°C, Humidity:40%~75%

### 13. Shelf Life :

2 years from manufacturing date

<b>TA-I</b>	<b>Alloy Film Chip Resistors Low Resistance (Standard) Halogen-Free</b>	Document No	TRL-XX0S0010
		Issued date	2014/08/06
		Page.	10 / 10

**14. ECN :**

Engineering Change Notice: The customer will be informed with ECN if there is significant modification on the characteristics and materials described in Approval Sheet.

**15. Manufacturing Country & City :**

TA-I TECHNOLOGY CO., LTD. ( Taiwan– Tao Yuan )  
Tel: 886-3-3246169 Fax : 886-3-3246167

**Associated companies :**

(1) FORTUNE TASK RESISTOR FACTORY ( China – Dongguan )  
Tel : 86-769-8339-4790~3 Fax : 86-769-8339-4794

(2) TA-I TECHNOLOGY (DONGGUAN ) CO., LTD. ( China –Dongguan )  
Tel : 86-769-8339-4790~3 Fax : 86-769-8339-4794

(3) TA-I TECHNOLOGY ( SU ZHOU ) CO., LTD. ( China – Su Zhou)  
Tel :86- 512-63457879 Fax : 86-512-63457869

(4) TAI OHM ELECTRONICS ( M ) SDN. BHD. ( Malaysia – Pulaupinang )  
Tel :604- 3900480 Fax : 604-3901481

(5) P.T.TAI ELECTRONICS Indonesia ( Indonesia – Jakarta )  
Tel :62-21-89830123 Fax : 62-21-89830703

## X-ON Electronics

Largest Supplier of Electrical and Electronic Components

*Click to view similar products for* [Current Sense Resistors - SMD category:](#)

*Click to view products by* [TA-I Tech manufacturer:](#)

Other Similar products are found below :

[CRL0603-FW-R700ELF](#) [PFS35-200RF1](#) [CD2015FC-0.10-1%](#) [PR2512FKF7W0R004L](#) [RC1005F124CS](#) [CSNL2512FT5L00](#)

[RL73K3AR56JTDF](#) [RL7520WT-R001-F](#) [RL7520WT-R020-F](#) [LRC-LR2512LF-01-R820J](#) [65709-330](#) [SP1R12J](#) [RL7520WT-R039-G](#)

[RL7520WT-R002-F](#) [RL7520WT-R005-F](#) [KRL1632E-C-R200-F-T5](#) [KRL1632E-C-R200-F-T1](#) [Y14880R02000B9R](#) [RLP73M2AR075FTDF](#)

[SR731ERTTP5R10F](#) [SR731ERTTP100J](#) [SR731ERTTP6R80F](#) [SR731ERTTP3R9J](#) [SR731ERTTP8R2J](#) [SR731ERTTP2R0J](#)

[SR731ERTTP4R7J](#) [SR731ERTTP9R1J](#) [SR731ERTTP1R0J](#) [SR731ERTTP2R2J](#) [SR731ERTTP5R1J](#) [SR731ERTTP6R8J](#) [SR731ERTTP9R10F](#)

[FCSL64R007JER](#) [73L4R10G](#) [73L4R75G](#) [73L4R33G](#) [73M1R051F](#) [73WL4R020J](#) [73L2R68J](#) [73L2R22J](#) [73L2R33J](#) [CC1512FC-0.015-5%](#)

[ULRG2-2512-R0075-F-LF-SLT](#) [KDV08DR220ET](#) [KDV12DR240ET](#) [SLN3TTED80L6F](#) [JW104X15X4](#) [JW105X19X5](#) [HVR06FTEV2403](#)

[JW104X5X4](#)