

Specification for Approval

Date: 2020/12/14

Customer : 深圳台慶

TAI-TECH P/N: TXF353229NF-121-P1

CUSTOMER P/N: _____

DESCRIPTION: _____

QUANTITY: _____ pcs

REMARK:		
Customer Approval Feedback		

西北臺慶科技股份有限公司
 TAI-TECH Advanced Electronics Co., Ltd
Headquarter:
 NO.1 YOU 4TH ROAD, YOUTH INDUSTRIAL DISTRICT, YANG-MEI,
 TAO-YUAN HSIEN, TAIWAN, R.O.C.
 TEL: +886-3-4641148 FAX: +886-3-4643565
 http://www.tai-tech.com.tw
 E-mail: sales@tai-tech.com.tw

Office:
 深圳辦公室
 11BC,Building B Fortune Plaza,NO.7002, Shennan Avenue, Futian
 District Shenzhen
 TEL: +86- 755-23972371 FAX: +86-755-23972340

臺慶精密電子(昆山)有限公司
 TAI-TECH ADVANCED ELECTRONICS(KUNSHAN) CO., LTD
 SHINWHA ROAD, KUNJIA HI-TECH INDUSTRIAL PARK, KUN-SHAN,
 JIANG-SU, CHINA
 TEL: +86-512-57619396 FAX: +86-512-57619688
 E-mail: sales@tai-tech.cn

慶邦電子元件(泗洪)有限公司
 TAIPAQ ELECTRONICS (SIHONG) CO., LTD
 Sihong development zone Suqian City, Jiangsu , CHINA.
 TEL: +86-527-88601191 FAX: +86-527-88601190
 E-mail: sales@taipaq.cn

Sales Dep.

APPROVED	CHECKED
管哲頌 Eric Kuan	劉璦瑄 Aries Liu

R&D Center

APPROVED	CHECKED	DRAWN
楊祥忠 Mike Yang	林志鴻 Zhi-Hong Lin	孔妍暄 Chloe Kung

SMD Pulse Transformer

TXF353229NF-121-P1

ECN HISTORY LIST					
REV	DATE	DESCRIPTION	APPROVED	CHECKED	DRAWN
1.0	20/12/14	新發行	楊祥忠	林志鴻	孔妍暄
備 註					

SMD Pulse Transformer

TXF353229NF-121-P1

1. Features

1. SMD type pulse transformers.
2. TXF353229NF is small size and low profile 3.50X3.20X2.9 mm.
3. 100% Lead(Pb) & Halogen-Free and RoHS compliant.
4. Operating temperature-40~ +85°C (Including self - temperature rise)



2. Dimension / Part Dimension

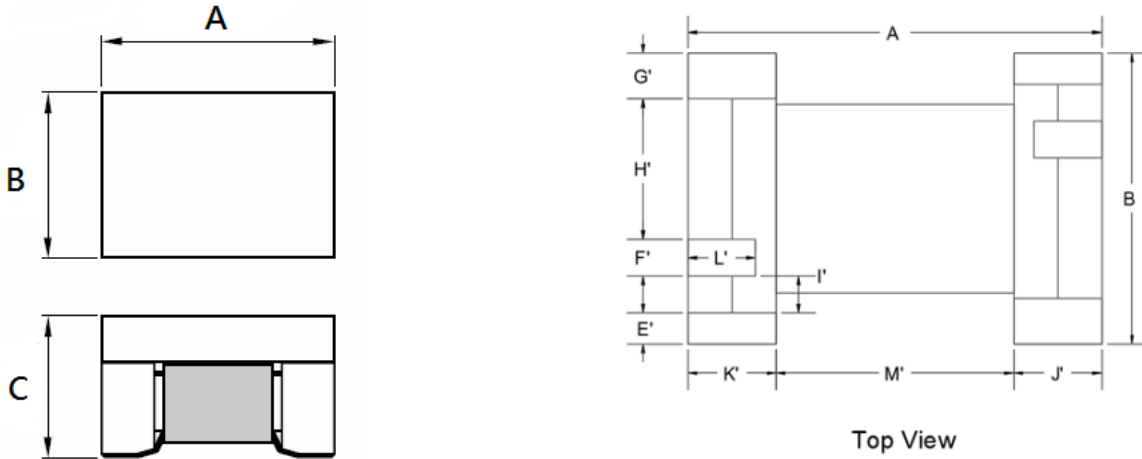

Dimensions in mm

Series	A(mm)	B(mm)	C(mm)	E'(mm)	F'(mm)	G'(mm)	H'(mm)	I'(mm)	J'(mm)	K'(mm)	L'(mm)	M'(mm)
353229NF	3.50±0.20	3.20±0.20	2.90 max	0.4±0.06	0.4±0.06	0.58±0.06	1.56±0.10	0.26±0.06	0.72±0.06	0.72±0.06	0.57±0.06	2.06±0.10

Units: mm

Recommended PC Board Pattern

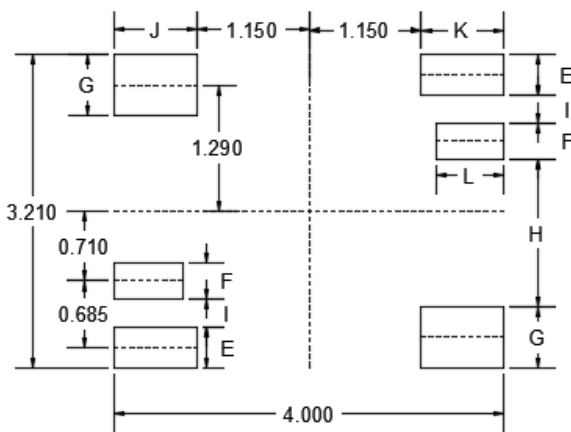

Solder paste stencil aperture recommendation

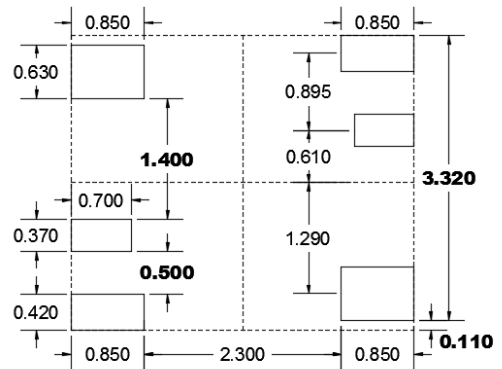

Series	D(mm)	E(mm)	F(mm)	G(mm)	H(mm)	I(mm)	J(mm)	K(mm)	L(mm)
353229NF	4.00	0.42	0.37	0.63	1.50	0.29	0.85	0.85	0.70

Units: mm

3. Part Numbering



- A: Series
- B: Dimension AxBxC
- C: Material Ferrite Core
- D: RoHs F=Lead Free
- E: Inductance 121=120 uH
- F: Control S/N

4. Specification

TAI-TECH Part Number	Inductance (uH) DC BIAS 0mA ①to② or ④to⑤	Test Frequency (Hz/V)	Insertion loss (Max)	Cp Capacitance (pF) ③to⑥	Turns ratio ①to② : ④to⑤	HI-POT ①②⑥to ④⑤③
TXF353229NF-121-P1	120uH (Min)	100K/0.1	1M-100MHz -1.0dB Max	35pF MAX	1:1	AC 1.5KV 60SEC

5. Schematic Diagram

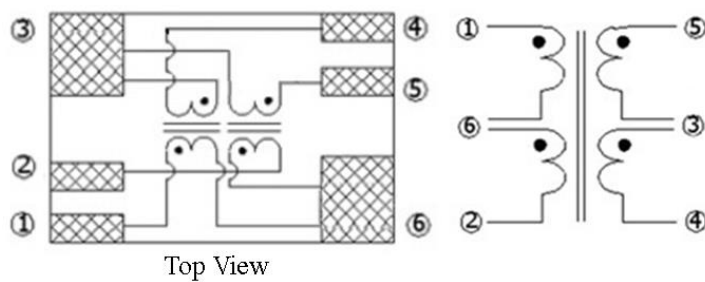

6. Materials

No.	Description	Specification
a.	Upper Plate	Ferrite
b.	Core	Ferrite Core
c.	Termination	Ag/Ni/Sn
d.	Wire	Enameled Copper Wire

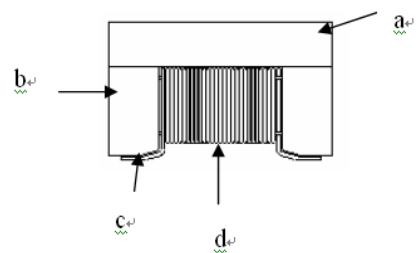

7. Reliability and Test Condition

Item	Performance	Test Condition
Operating temperature	-40~ +85℃ (Including self - temperature rise)	
Storage temperature	-40~ +85℃ (on board)	
Electrical Performance Test		
Ls	Refer to standard electrical characteristics list.	Agilent-4285A+ Agilent -16334A
Cp		HP-4192A
Insertion Loss		Agilent E5071C
Reliability Test		
Life Test	Appearance : No damage. Inductance : within±10% of initial value Cp: within ±15% of initial value and shall not Insertion Loss : within Specification	Preconditioning: Run through IR reflow for 3 times.(IPC/JEDEC J-STD-020E Classification Reflow Profiles) Temperature : 85±2℃ Applied current : rated current Duration : 1000±12hrs Measured at room temperature after placing for 24±2 hrs
Load Humidity		Preconditioning: Run through IR reflow for 3 times.(IPC/JEDEC J-STD-020E Classification Reflow Profiles) Humidity : 85±2% R.H, Temperature : 85℃ ±2℃ Duration : 1000hrs Min. Bead : with 100% rated current Inductance: with 10% rated current Measured at room temperature after placing for 24±2 hrs
Moisture Resistance		Preconditioning: Run through IR reflow for 3 times.(IPC/JEDEC J-STD-020E Classification Reflow Profiles) 1. Baked at50℃ for 25hrs, measured at room temperature after placing for 4 hrs. 2. Raise temperature to 65±2℃ 90-100%RH in 2.5hrs, and keep 3 hours, cool down to 25℃ in 2.5hrs. 3. Raise temperature to 65±2℃ 90-100%RH in 2.5hrs, and keep 3 hours, cool down to 25℃ in 2.5hrs,keep at 25℃ for 2 hrs then keep at -10℃ for 3 hrs 4. Keep at 25℃ 80-100%RH for 15min and vibrate at the frequency of 10 to 55 Hz to 10 Hz, measure at room temperature after placing for 1~2 hrs.
Thermal shock		Preconditioning: Run through IR reflow for 3 times.(IPC/JEDEC J-STD-020E Classification Reflow Profiles) Condition for 1 cycle Step1 : -40±2℃ 30±5min Step2 : 25±2℃ ≤0.5min Step3 : 85±2℃ 30±5min Number of cycles : 500 Measured at room temperature after placing for 24±2 hrs
Vibration		Oscillation Frequency: 10Hz~2KHz~10Hz for 20 minute Equipment : Vibration checker Total Amplitude:10g Testing Time : 12 hours(20 minutes, 12 cycles each of 3 orientations)

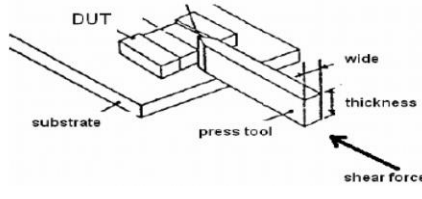
Item	Performance	Test Condition															
Bending	Appearance : No damage. Inductance : within±10% of initial value	Shall be mounted on a FR4 substrate of the following dimensions: >=0805 inch(2012mm):40x100x1.2mm <0805 inch(2012mm):40x100x0.8mm Bending depth: >=0805 inch(2012mm):1.2mm <0805 inch(2012mm):0.8mm duration of 10 sec.															
Shock	Cp: within ±15% of initial value and shall not Insertion Loss : within Specification	<table border="1"> <thead> <tr> <th>Type</th> <th>Peak value (g's)</th> <th>Normal duration (D) (ms)</th> <th>Wave form</th> <th>Velocity change (Vi)ft/sec</th> </tr> </thead> <tbody> <tr> <td>SMD</td> <td>50</td> <td>11</td> <td>Half-sine</td> <td>11.3</td> </tr> <tr> <td>Lead</td> <td>50</td> <td>11</td> <td>Half-sine</td> <td>11.3</td> </tr> </tbody> </table>	Type	Peak value (g's)	Normal duration (D) (ms)	Wave form	Velocity change (Vi)ft/sec	SMD	50	11	Half-sine	11.3	Lead	50	11	Half-sine	11.3
Type	Peak value (g's)	Normal duration (D) (ms)	Wave form	Velocity change (Vi)ft/sec													
SMD	50	11	Half-sine	11.3													
Lead	50	11	Half-sine	11.3													
Solder ability	More than 95% of the terminal electrode should be covered with solder.	a. Method B, 4 hrs @155°C dry heat @235°C±5°C Testing Time :5 +0/-0.5 seconds b. Method D category 3. (8hours ± 15 min)@ 260°C±5°C Testing Time :30 +0/-0.5 seconds															
Resistance to Soldering Heat		Depth: completely cover the termination <table border="1"> <thead> <tr> <th>Temperature(°C)</th> <th>Time(s)</th> <th>Temperature ramp/immersion and emersion rate</th> <th>Number of heat cycles</th> </tr> </thead> <tbody> <tr> <td>260 ±5 (solder temp)</td> <td>10 ±1</td> <td>25mm/s ±6 mm/s</td> <td>1</td> </tr> </tbody> </table>	Temperature(°C)	Time(s)	Temperature ramp/immersion and emersion rate	Number of heat cycles	260 ±5 (solder temp)	10 ±1	25mm/s ±6 mm/s	1							
Temperature(°C)	Time(s)	Temperature ramp/immersion and emersion rate	Number of heat cycles														
260 ±5 (solder temp)	10 ±1	25mm/s ±6 mm/s	1														
Terminal Strength	Appearance : No damage. Inductance : within±10% of initial value Cp: within ±15% of initial value and shall not Insertion Loss : within Specification	Preconditioning: Run through IR reflow for 3 times.(IPC/JEDEC J-STD-020E Classification Reflow Profiles With the component mounted on a PCB with the device to be tested, apply a force(>0805:1kg , <=0805:0.5kg)to the side of a device being tested. This force shall be applied for 60 +1 seconds. Also the force shall be applied gradually as not to apply a shock to the component being tested. 															

8. Soldering and Mounting

8-1. Soldering

Mildly activated rosin fluxes are preferred. TAI-TECH terminations are suitable for re-flow soldering systems. If hand soldering cannot be avoided, the preferred technique is the utilization of hot air soldering tools.

8-1.1 IR Soldering Reflow:

Recommended temperature profiles for lead free re-flow soldering in Figure 1. Table 1.1&1.2 (J-STD-020E)

8-1.2 Soldering Iron:

Products attachment with a soldering iron is discouraged due to the inherent process control limitations. In the event that a soldering iron must be employed the following precautions are recommended. (Figure 2.)

- Preheat circuit and products to 150°C
- Never contact the ceramic with the iron tip
- Use a 20 watt soldering iron with tip diameter of 1.0mm
- 350°C tip temperature (max)
- 1.0mm tip diameter (max)
- Limit soldering time to 4~5sec.

Fig.1 IR Soldering Reflow

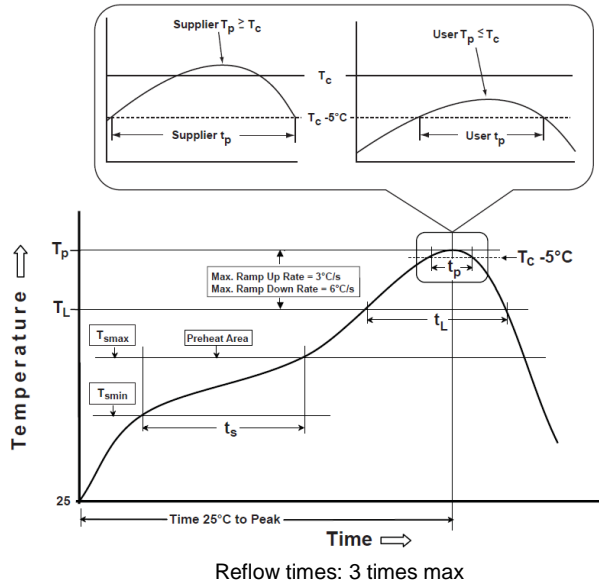
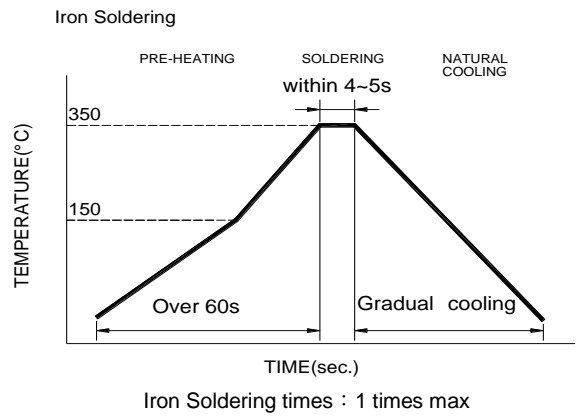

Fig.2 Iron soldering temperature profiles



Iron Soldering times : 1 times max

Table (1.1): Reflow Profiles

Profile Type:	Pb-Free Assembly
Preheat -Temperature Min(T_{smin}) -Temperature Max(T_{smax}) -Time(t_s)from(T_{smin} to T_{smax})	150°C 200°C 60-120seconds
Ramp-up rate(T_L to T_p)	3°C/second max.
Liquidus temperature(T_L) Time(t_L)maintained above T_L	217°C 60-150 seconds
Classification temperature(T_c)	See Table (1.2)
Time(t_p) at $T_c - 5^\circ\text{C}$ (T_p should be equal to or less than T_c .)	< 30 seconds
Ramp-down rate(T_p to T_L)	6°C /second max.
Time 25°C to peak temperature	8 minutes max.

T_p: maximum peak package body temperature, **T_c**: the classification temperature.

For user (customer) **T_p** should be equal to or less than **T_c**.

Table (1.2) Package Thickness/Volume and Classification Temperature (T_c)

	Package Thickness	Volume mm ³ <350	Volume mm ³ 350-2000	Volume mm ³ >2000
PB-Free Assembly	<1.6mm	260°C	260°C	260°C
	1.6-2.5mm	260°C	250°C	245°C
	≥2.5mm	250°C	245°C	245°C

Reflow is referred to standard IPC/JEDEC J-STD-020E ◦

9. Packaging Information

9-1. Reel Dimension

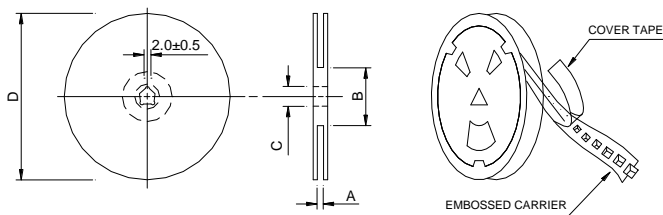

Type	A(mm)	B(mm)	C(mm)	D(mm)
13"x12mm	12.5±0.5	100±2	13.5±0.5	330

9-2. Tape Dimension / 12mm

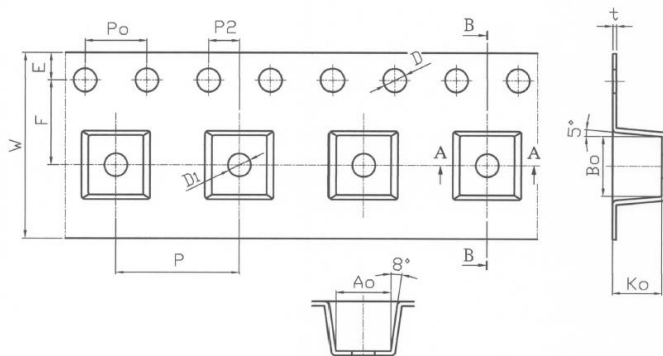

Series	P(mm)	Po(mm)	P2(mm)	Bo(mm)	Ao(mm)	Ko(mm)	D(mm)	D1(mm)	E(mm)	F(mm)	W(mm)	t(mm)
TXF353229NF	8.00±0.10	4.00±0.10	2.00±0.05	3.90±0.10	3.55±0.10	3.20±0.10	1.05+0.10/-0.00	1.50±0.10	1.75±0.10	5.50±0.05	12.00±0.10	0.30±0.05

9-3. Packaging Quantity

Chip size	Chip/Reel	Inner Box	Carton
TXF353229NF	2000	4000	32000

9-4. Tearing Off Force

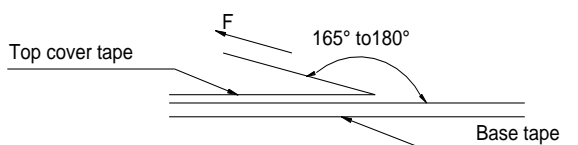

The force for tearing off cover tape is 15 to 80 grams in the arrow direction under the following conditions.

Room Temp. (°C)	Room Humidity (%)	Room atm (hPa)	Tearing Speed mm/min
5-35	45-85	860-1060	300

Application Notice

- Storage Conditions(component level)
To maintain the solderability of terminal electrodes:
 1. TAI-TECH products meet IPC/JEDEC J-STD-020E standard-MSL, level 1.
 2. Temperature and humidity conditions: Less than 40°C and 60% RH.
 3. Recommended products should be used within 6 months form the time of delivery.
 4. The packaging material should be kept where no chlorine or sulfur exists in the air.
- Transportation
 1. Products should be handled with care to avoid damage or contamination from perspiration and skin oils.
 2. The use of tweezers or vacuum pick up is strongly recommended for individual components.
 3. Bulk handling should ensure that abrasion and mechanical shock are minimized.

X-ON Electronics

Largest Supplier of Electrical and Electronic Components

Click to view similar products for [Pulse Transformers](#) category:

Click to view products by [Tai-Tech](#) manufacturer:

Other Similar products are found below :

[E4001NLT](#) [1879401-1](#) [IF-18-0269-N](#) [T1042NLT](#) [G501](#) [PT5010](#) [PE-65457NLT](#) [HM2101NLT](#) [CTX33-18971-R](#) [PG1427.001NLT](#)
[B78307X0001](#) [CL4532A-201](#) [PA2748NLT](#) [PE-68023NLT](#) [FB020G00](#) [TS21CHF](#) [TXF353229NF-121-P1](#) [HR601233E](#) [TGMR-512V6LF](#)
[B78307A2276A003](#) [HX6106NLT](#) [P0926NL](#) [TGMR-430V8LF](#) [TGMR-501V6LF](#) [HX6096NL](#) [PE-63387NL](#) [B82804A0304A225](#) [TGM-](#)
[040P3RL](#) [PA3493NLT](#) [CX2147NLT](#) [HM41-11210LF](#) [TGM-210NSRL](#) [TGM-240NSRL](#) [TGMR-511V6LF](#) [TGM-240NSLF](#) [TGM-030P3RL](#)
[T60403-F5046-X007](#) [TGM-H280V8LF](#) [T60403-D4097-X052](#) [HU4103NL](#) [78601/8JC-R](#) [TGMR-H540V8LF](#) [TGAD-290NARL](#) [TGM-](#)
[H240V8LF](#) [78601/2JC-R](#) [TGAD-292NARL](#) [HU4006NL](#) [HU4108NL](#) [HX6096NLT](#) [78613/1JC](#)