

Small Signal Product

500mW Hermetically Sealed Glass Fast Switching Diodes

FEATURES

- Small hermetically sealed glass SMD package
- High switching speed: Max. 4 ns
- Continuous reverse voltage: Max. 75V
- Repetitive peak reverse voltage: Max. 75V
- Repetitive peak forward current: Max. 450 mA



SOD80C



MECHANICAL DATA

- Polarity: Indicated by black cathode band

Hermetically Sealed Glass

MAXIMUM RATINGS AND ELECTRICAL CHARACTERISTICS (T _A =25°C unless otherwise noted)			
PARAMETER	SYMBOL	VALUE	UNIT
Repetitive Peak Reverse Voltage	V _{RRM}	75	V
Continuous Reverse Voltage	V _R	75	V
Continuous Forward Current Fig. 2, (Note 1)	I _F	200	mA
Repetitive Peak Forward Current	I _{FRM}	450	mA
Non-Repetitive Peak Forward Surge Current	I _{FSM}	4	A
Square Wave : T _J =25°C Prior to Surge : See Fig. 4			
t=1μs			
t=1ms			
		0.5	
Total Power Dissipation T _{amb} =25°C, (Note 1)	P _{tot}	500	mW
Operating Junction Temperature	T _J	200	°C
Storage Temperature Range	T _{STG}	-65 to 200	°C

PARAMETER	SYMBOL	MIN	MAX	UNIT
Forward Voltage See Fig. 3 I _F =10mA	V _F	-	1.0	V
Reverse Leakage Current V _R =20V See Fig. 5	I _R	-	25.0	nA
V _R =20V T _J =150°C		-	50.0	μA
Junction Capacitance V _R =0 f=1.0MHz	C _J	-	4.0	pF
Reverse Recovery Time (Note 2)	t _{rr}	-	4.0	ns
Forward Recovery Voltage I _F =50 mA tr=20ns	V _{fr}	-	2.5	V

Note 1 : Device mounted on an FR4 printed-circuit board

Note 2 : Reverse recovery test conditions : I_F=10mA, I_R=60mA, R_L=100Ω, I_{RR}=1m A

Small Signal Product

RATINGS AND CHARACTERISTICS CURVES

($T_A=25^\circ\text{C}$ unless otherwise noted)

Fig. 1 Maximum Permissible Continuous Forward Current As A Function of Ambient Temperature

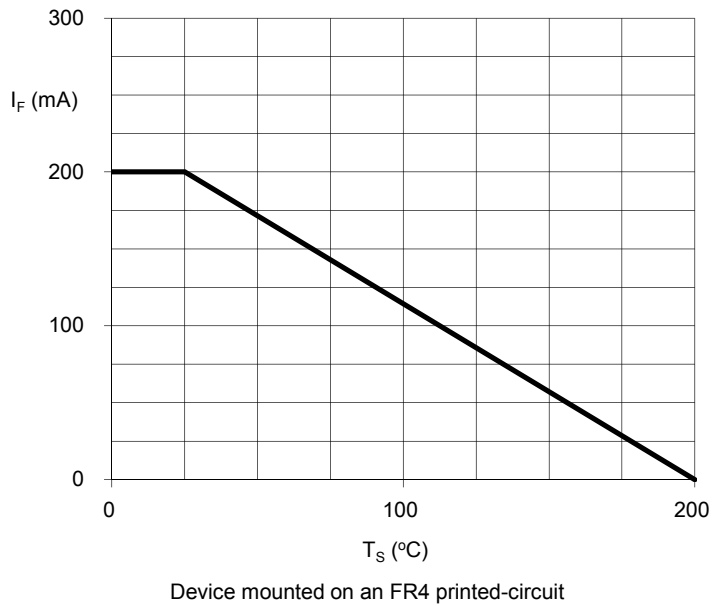

Fig. 2 Forward Current As A Function of Forward Voltage

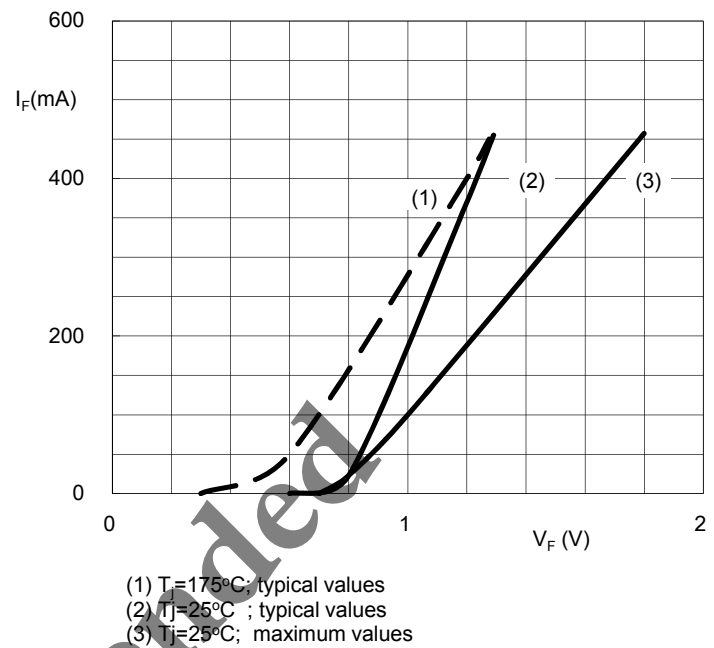
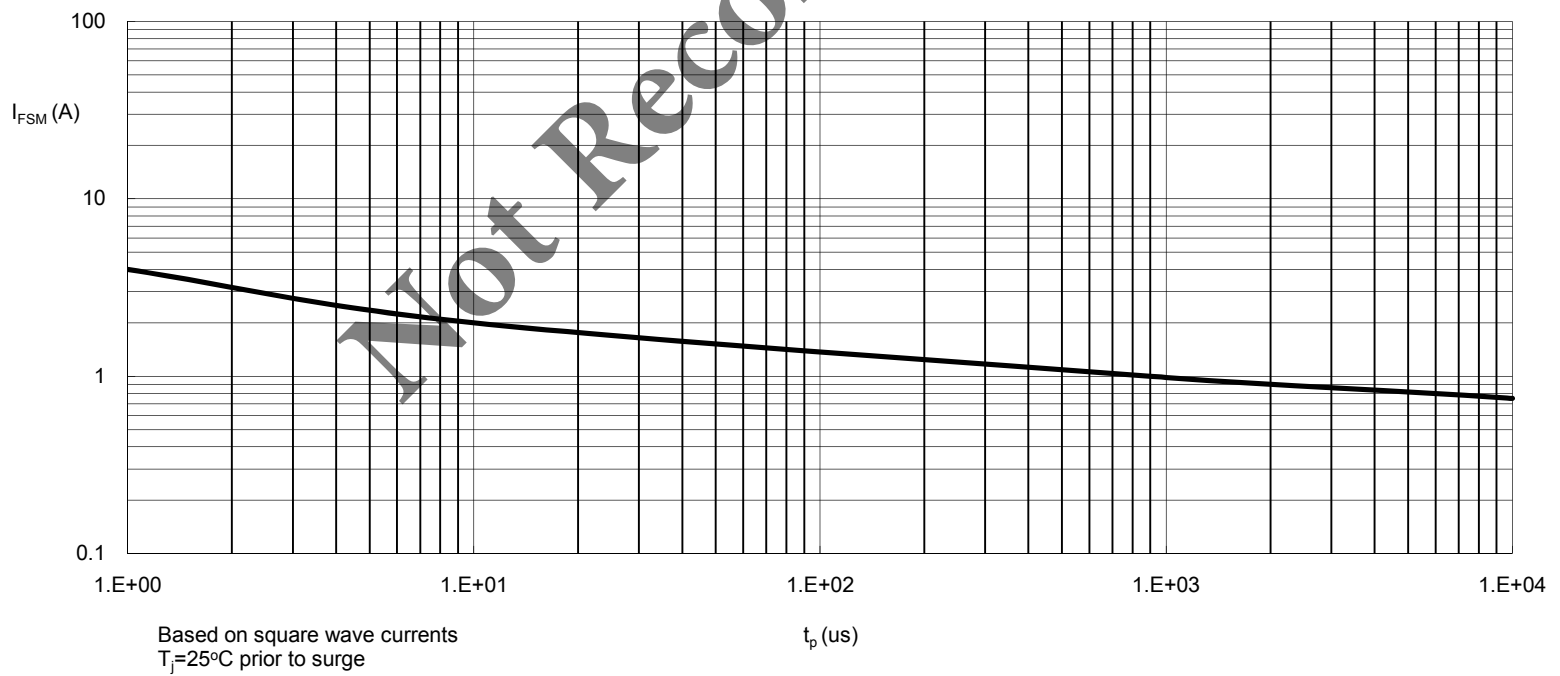

Fig. 3 Maximum Permissible Non-Repetitive Peak Forward Current As A Function of Pulse Duration



Small Signal Product

Fig. 4 Reverse Current As A Function of Junction Temperature

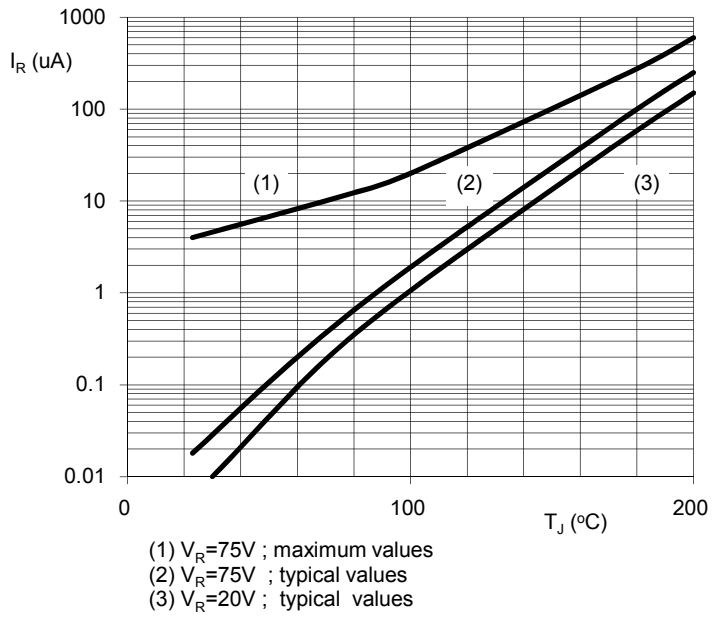
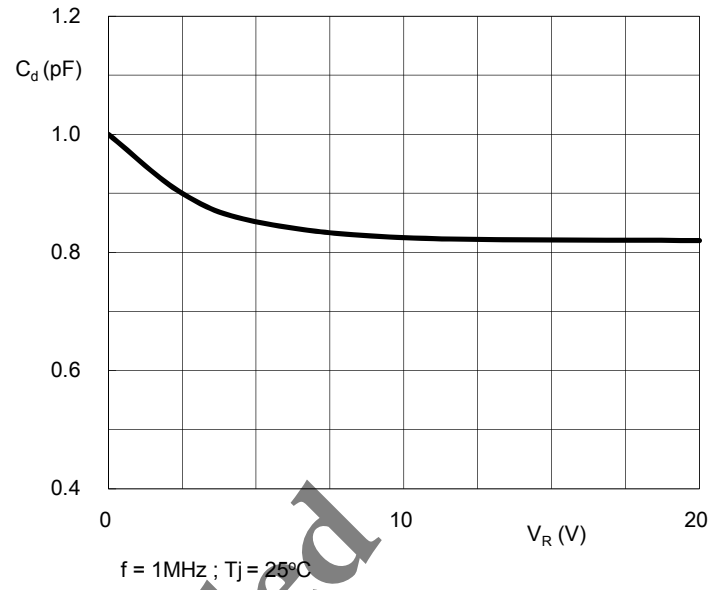

Fig. 5 Diode Capacitance As A Function of Reverse Voltage ; Typical Values



Not Recommended

Small Signal Product

ORDER INFORMATION (EXAMPLE)

LL4148L LOG

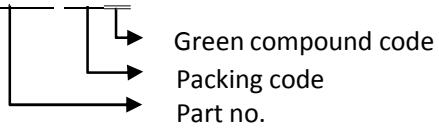

PACKAGE OUTLINE DIMENSION

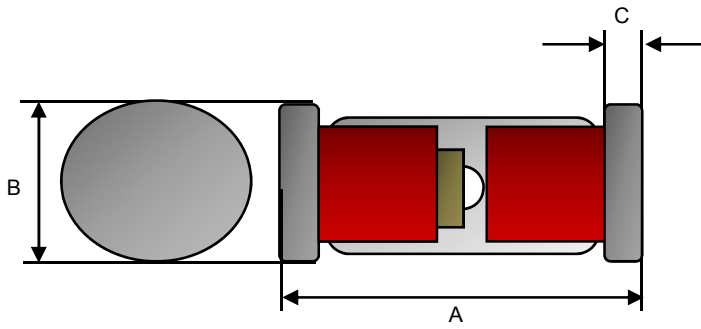

DIM.	Unit (mm)		Unit (inch)	
	Min	Max	Min	Max
A	3.30	3.70	0.130	0.146
B	1.40	1.60	0.055	0.063
C	0.20	0.50	0.008	0.020

SUGGEST PAD LAYOUT

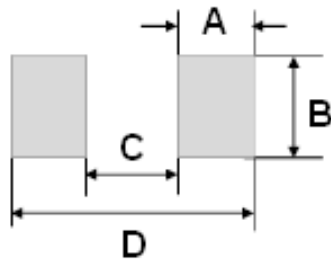

DIM.	Unit (mm)	Unit (inch)
	Typ.	Typ.
A	1.25	0.049
B	2.00	0.079
C	2.50	0.098
D	5.00	0.197

Not Recommended

Not Recommended

Notice

Specifications of the products displayed herein are subject to change without notice. TSC or anyone on its behalf, assumes no responsibility or liability for any errors or inaccuracies.

Information contained herein is intended to provide a product description only. No license, express or implied, to any intellectual property rights is granted by this document. Except as provided in TSC's terms and conditions of sale for such products, TSC assumes no liability whatsoever, and disclaims any express or implied warranty, relating to sale and/or use of TSC products including liability or warranties relating to fitness for a particular purpose, merchantability, or infringement of any patent, copyright, or other intellectual property right.

The products shown herein are not designed for use in medical, life-saving, or life-sustaining applications. Customers using or selling these products for use in such applications do so at their own risk and agree to fully indemnify TSC for any damages resulting from such improper use or sale.

X-ON Electronics

Largest Supplier of Electrical and Electronic Components

Click to view similar products for [Diodes - General Purpose, Power, Switching category:](#)

Click to view products by [Taiwan Semiconductor manufacturer:](#)

Other Similar products are found below :

[RD0306T-H](#) [BAV17-TR](#) [BAV19-TR](#) [1N3611](#) [NTE156A](#) [NTE525](#) [NTE571](#) [NTE574](#) [NTE5804](#) [NTE5806](#) [NTE6244](#) [1SS181-TP](#)
[1SS193,LF](#) [1SS400CST2RA](#) [SDAA13](#) [SHN2D02FUTW1T1G](#) [LS4151GS08](#) [1N4449](#) [1N456A](#) [1N4934-E3/73](#) [1N914B](#) [1N914BTR](#)
[RFUH20TB3S](#) [BAS 28 E6327](#) [BAV199-TP](#) [BAW56DWQ-7-F](#) [BAW75-TAP](#) [MM230L-CAA](#) [IDW40E65D1](#) [JAN1N3600](#) [LL4151-GS18](#)
[053684A](#) [SMMSD4148T3G](#) [707803H](#) [NSVDAN222T1G](#) [SP000010217](#) [CDSZC01100-HF](#) [BAV199E6433HTMA1](#) [BAV70M3T5G](#)
[SMBT2001T1G](#) [NTE5801](#) [NTE5800](#) [NTE5808](#) [NTE6240](#) [NTE6248](#) [BAS28-7](#) [BAW56HDW-13](#) [BAS28 TR](#) [VS-HFA04SD60STR-M3](#)
[NSVM1MA152WKT1G](#)