

### Features

- ✧ For surface mounted application
- ✧ Glass passivated junction chip
- ✧ Built-in strain relief, ideal for automated placement
- ✧ Plastic material used carries Underwriters Laboratory Classification 94V-0
- ✧ Fast switching for high efficiency
- ✧ High temperature soldering: 260°C / 10 seconds at terminals
- ✧ Green compound with suffix "G" on packing code & prefix "G" on datecode



### Mechanical Data

- ✧ Case: Molded plastic
- ✧ Terminals: Pure tin plated, Lead free
- ✧ Polarity: Indicated by cathode band
- ✧ Packing: 16mm tape per EIA STD RS-481
- ✧ Weight: 0.21 grams

### Ordering Information (example)

Part No.	Package	Packing	Packing code	Packing code (Green)
RS3A	SMC	850 / 7" REEL	R7	R7G

### Maximum Ratings and Electrical Characteristics

Rating at 25 °C ambient temperature unless otherwise specified.

Parameter	Symbol	RS 3A	RS 3B	RS 3D	RS 3G	RS 3J	RS 3K	RS 3M	Unit
Maximum Repetitive Peak Reverse Voltage	$V_{RRM}$	50	100	200	400	600	800	1000	V
Maximum RMS Voltage	$V_{RMS}$	35	70	140	280	420	560	700	V
Maximum DC Blocking Voltage	$V_{DC}$	50	100	200	400	600	800	1000	V
Maximum Average Forward Rectified Current	$I_{F(AV)}$	3							A
Peak Forward Surge Current, 8.3 ms Single Half Sine-wave Superimposed on Rated Load (JEDEC method)	$I_{FSM}$	100							A
Maximum Instantaneous Forward Voltage (Note 1) @ 3 A	$V_F$	1.3							V
Maximum Reverse Current @ Rated VR $T_A=25\text{ }^\circ\text{C}$ $T_A=125\text{ }^\circ\text{C}$	$I_R$	10 250							$\mu\text{A}$
Maximum Reverse Recovery Time (Note 2)	$T_{rr}$	150			250		500		nS
Typical Junction Capacitance (Note 3)	$C_j$	60							pF
Typical Thermal Resistance	$R_{\theta JA}$ $R_{\theta JL}$	50 15							$^\circ\text{C/W}$
Operating Temperature Range	$T_J$	- 55 to + 150							$^\circ\text{C}$
Storage Temperature Range	$T_{STG}$	- 55 to + 150							$^\circ\text{C}$

Note 1: Pulse Test with PW=300 usec, 1% Duty Cycle

Note 2: Reverse Recovery Test Conditions:  $I_F=0.5\text{A}$ ,  $I_R=1.0\text{A}$ ,  $I_{RR}=0.25\text{A}$

Note 3: Measured at 1 MHz and Applied Reverse Voltage of 4.0V D.C.

RATINGS AND CHARACTERISTIC CURVES (RS3A THRU RS3M)

FIG.1 FORWARD CURRENT DERATING CURVE

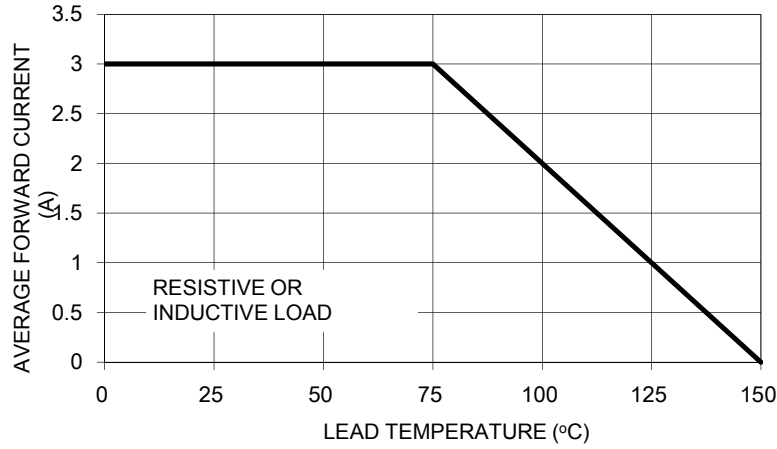

FIG. 2 TYPICAL REVERSE CHARACTERISTICS

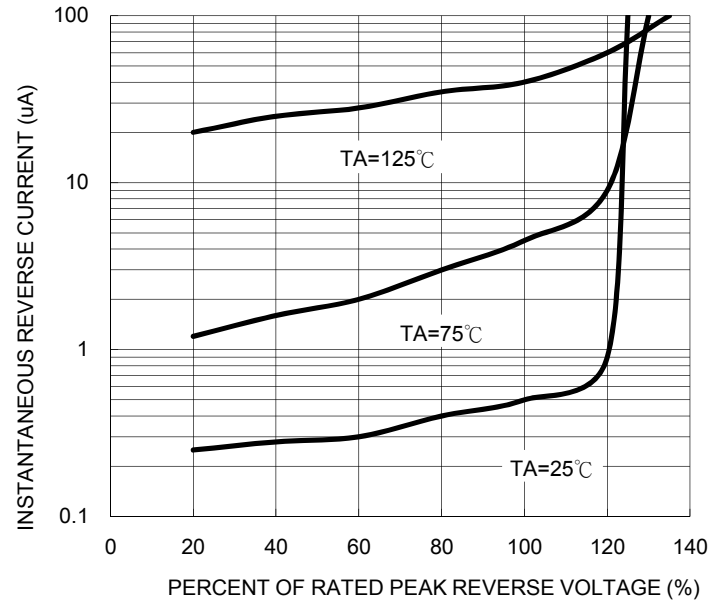

FIG. 3 MAXIMUM NON-REPETITIVE FORWARD SURGE CURRENT

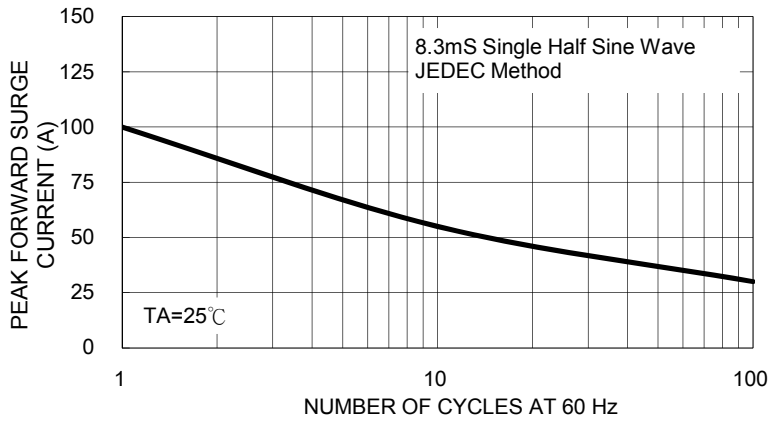

FIG. 5 TYPICAL FORWARD CHARACTERISTICS

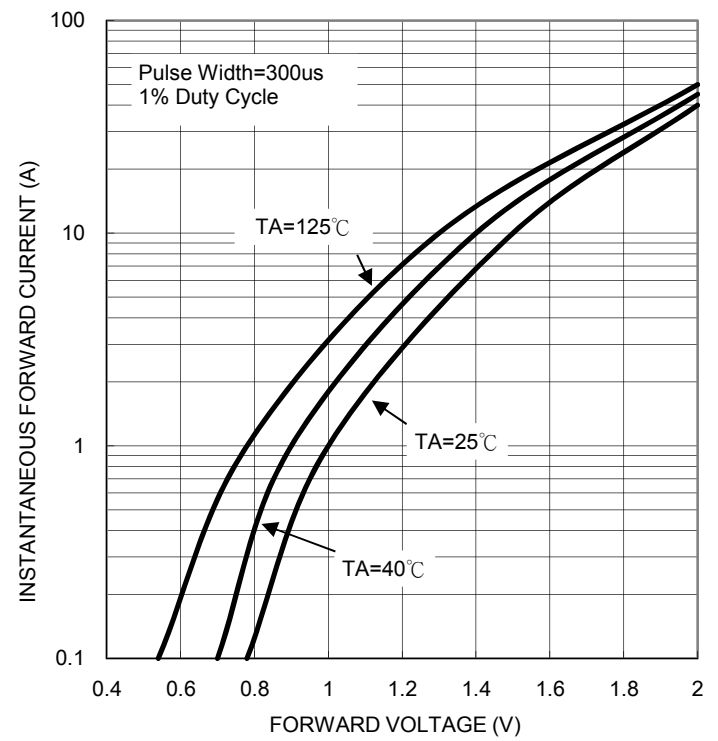

FIG. 4 TYPICAL JUNCTION CAPACITANCE

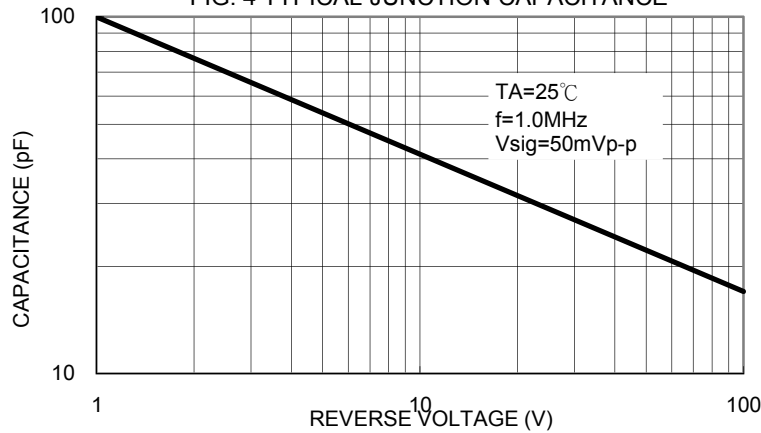
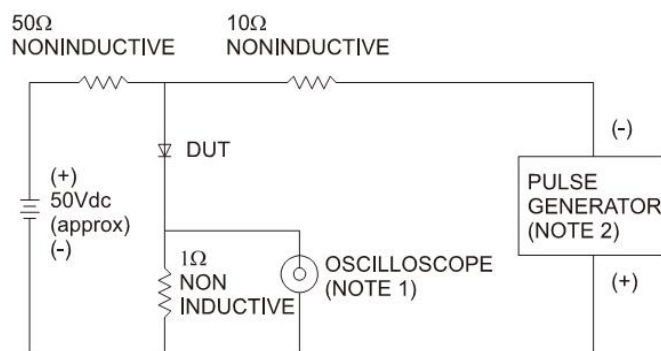
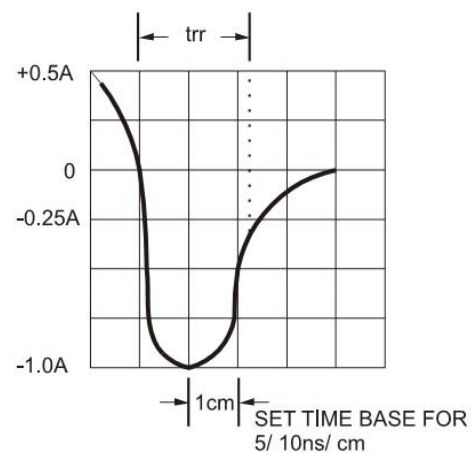

FIG.6- REVERSE RECOVERY TIME CHARACTERISTIC AND TEST CIRCUIT DIAGRAM



NOTES: 1. Rise Time=7ns max. Input Impedance= 1 megohm 22pf  
2. Rise Time=10ns max. Source Impedance= 50 ohms



**Ordering information**

Part No.	Package	Packing	Packing code	Packing code (Green)
RS3x (Note)	SMC	850 / 7" REEL	R7	R7G
	SMC	3K / 13" REEL	R6	R6G
	SMC	3K / 13" Plastic REEL	M6	M6G

Note: "x" is Device Code from "A" thru "M".

**Tape & Reel specification**

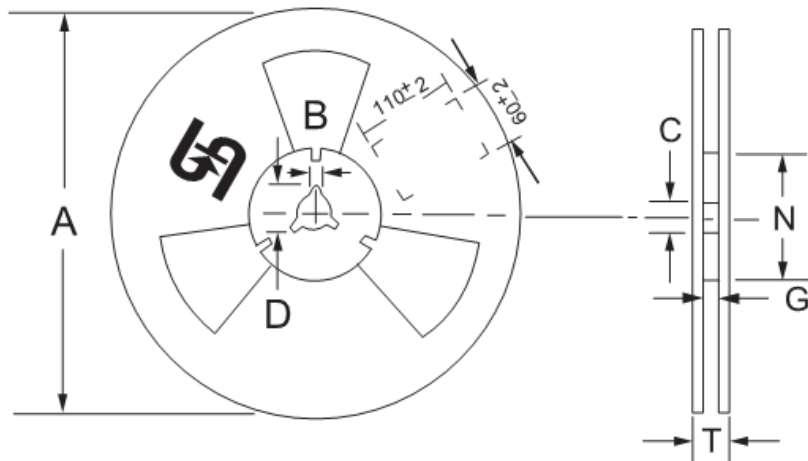
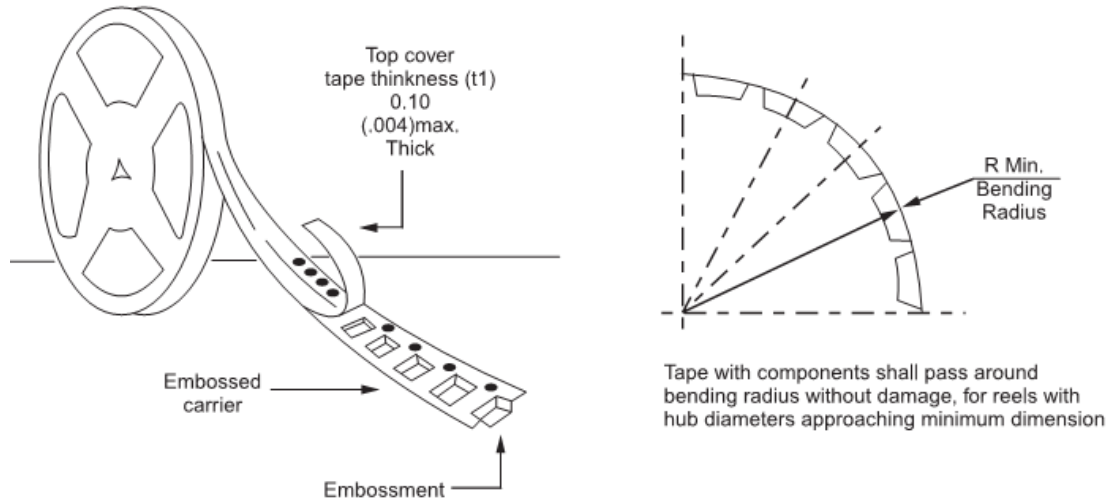

Reel Size	Tape Size	A	B	C	D	N	G	T
		±2.0	±0.4	+0.5;-0.2	min	±1.0	+0.8;-0	max
7"	16mm	178	1.9	13	21	62	16.2	18.6
Reel Size	Tape Size	A	B	C	D	N	G	T
		max	±0.5	±0.5	min	±0.5	+2.0;-0	max
13"	16mm	330	2	13	20.2	75	16.4	22.4

Unit (mm)

**Suggested PAD Layout**

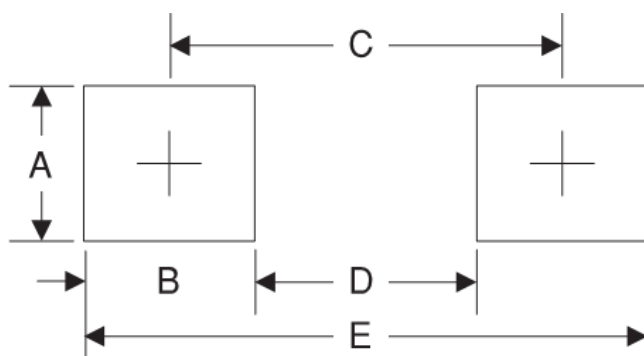

Symbol	Unit(mm)
A	3.3
B	2.5
C	6.8
D	4.4
E	9.3

**Dimensions**

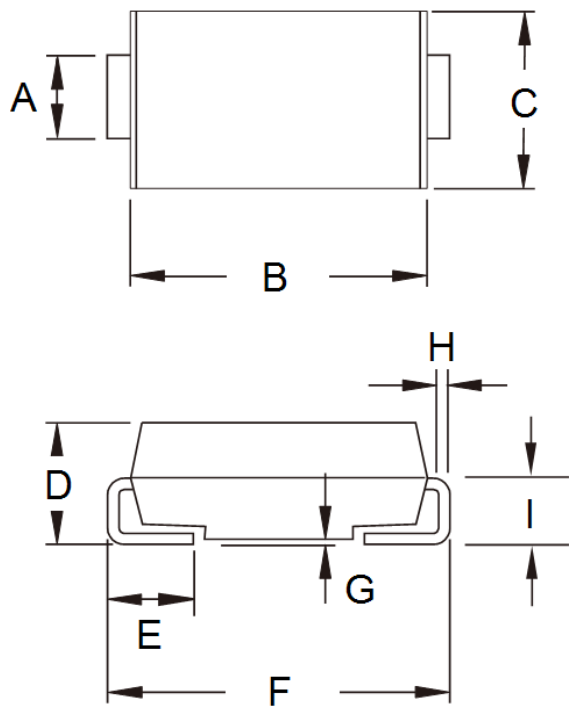

DIM.	Unit(mm)		Unit(inch)	
	Min	Max	Min	Max
A	2.90	3.20	0.114	0.126
B	6.60	7.11	0.260	0.280
C	5.59	6.22	0.220	0.245
D	2.00	2.62	0.079	0.103
E	1.00	1.60	0.039	0.063
F	7.75	8.13	0.305	0.320
G	0.10	0.20	0.004	0.008
H	0.15	0.31	0.006	0.012
I	1.26	1.56	0.050	0.061

**Marking Diagram**



- P/N = Specific Device Code
- G = Green Compound
- YW = Date Code
- F = Factory Code

## X-ON Electronics

Largest Supplier of Electrical and Electronic Components

*Click to view similar products for [Rectifiers](#) category:*

*Click to view products by [Taiwan Semiconductor](#) manufacturer:*

Other Similar products are found below :

[70HFR40](#) [RL252-TP](#) [150KR30A](#) [1N5397](#) [NTE5841](#) [NTE6038](#) [SCF5000](#) [1N4002G](#) [1N4005-TR](#) [JANS1N6640US](#) [481235F](#)  
[RRE02VS6SGTR](#) [067907F](#) [MS306](#) [70HF40](#) [T85HFL60S02](#) [US2JFL-TP](#) [A1N5404G-G](#) [CRS04\(T5L,TEMQ\)](#) [ACGRA4007-HF](#)  
[ACGRB207-HF](#) [CLH03\(TE16L,Q\)](#) [ACGRC307-HF](#) [ACEFC304-HF](#) [NTE6356](#) [NTE6359](#) [NTE6002](#) [NTE6023](#) [NTE6039](#) [NTE6077](#)  
[85HFR60](#) [40HFR60](#) [70HF120](#) [85HFR80](#) [D126A45C](#) [SCF7500](#) [D251N08B](#) [SCHJ22.5K](#) [SM100](#) [SCPA2](#) [SCH10000](#) [SDHD5K](#) [VS-](#)  
[12FL100S10](#) [ACGRA4001-HF](#) [D1821SH45T PR](#) [D1251S45T](#) [NTE5990](#) [NTE6358](#) [NTE6162](#) [NTE5850](#)