

1A, 400V - 1000V Standard Surface Mount Rectifier

FEATURES

- Glass passivated chip junction
- Ideal for automated placement
- Low forward voltage drop
- High surge current capability
- Moisture sensitivity level: level 1, per J-STD-020
- RoHS Compliant
- Halogen-free according to IEC 61249-2-21

APPLICATIONS

- DC to DC converter
- Switching mode converters and inverters
- General purpose

MECHANICAL DATA

- Case: SOD-123FL
- Molding compound meets UL 94V-0 flammability rating
- Terminal: Matte tin plated leads, solderable per J-STD-002
- Meet JESD 201 class 1A whisker test
- Polarity: Indicated by cathode band
- Weight: 0.016g (approximately)

| KEY PARAMETERS | | |
|----------------|------------|------|
| PARAMETER | VALUE | UNIT |
| I_F | 1 | A |
| V_{RRM} | 400 - 1000 | V |
| I_{FSM} | 30 | A |
| $T_{J\ MAX}$ | 150 | °C |
| Package | SOD-123FL | |
| Configuration | Single die | |



SOD-123FL



| ABSOLUTE MAXIMUM RATINGS ($T_A = 25^\circ\text{C}$ unless otherwise noted) | | | | | |
|--|--------------|--------------|-------|-------|------|
| PARAMETER | SYMBOL | S1GFL | S1JFL | S1MFL | UNIT |
| Marking code on the device | | SGF | SJF | SMF | |
| Repetitive peak reverse voltage | V_{RRM} | 400 | 600 | 1000 | V |
| Reverse voltage, total rms value | $V_{R(RMS)}$ | 280 | 420 | 700 | V |
| Forward current | I_F | 1 | | | A |
| Peak forward surge current, 8.3ms single half sine-wave superimposed on rated load | I_{FSM} | 30 | | | A |
| Junction temperature | T_J | - 55 to +150 | | | °C |
| Storage temperature | T_{STG} | - 55 to +150 | | | °C |

| THERMAL PERFORMANCE | | | |
|--|-----------------|------------|-------------|
| PARAMETER | SYMBOL | TYP | UNIT |
| Junction-to-lead thermal resistance | $R_{\theta JL}$ | 25 | °C/W |
| Junction-to-ambient thermal resistance | $R_{\theta JA}$ | 85 | °C/W |

| ELECTRICAL SPECIFICATIONS ($T_A = 25^\circ\text{C}$ unless otherwise noted) | | | | | |
|---|---|---------------|------------|------------|---------------|
| PARAMETER | CONDITIONS | SYMBOL | TYP | MAX | UNIT |
| Forward voltage ⁽¹⁾ | $I_F = 1\text{A}, T_J = 25^\circ\text{C}$ | V_F | - | 1.1 | V |
| Reverse current @ rated V_R ⁽²⁾ | $T_J = 25^\circ\text{C}$ | I_R | - | 1 | μA |
| | $T_J = 125^\circ\text{C}$ | | - | 50 | μA |
| Junction capacitance | 1MHz, $V_R = 4.0\text{V}$ | C_J | 7 | - | pF |

Notes:

1. Pulse test with $PW = 0.3\text{ms}$
2. Pulse test with $PW = 30\text{ms}$

| ORDERING INFORMATION | | |
|------------------------------------|----------------|----------------------|
| ORDERING CODE⁽¹⁾ | PACKAGE | PACKING |
| S1xFL | SOD-123FL | 10,000 / Tape & Reel |

Notes:

1. "x" defines voltage from 400V(S1GFL) to 1000V(S1MFL)

CHARACTERISTICS CURVES

($T_A = 25^\circ\text{C}$ unless otherwise noted)

Fig.1 Forward Current Derating Curve

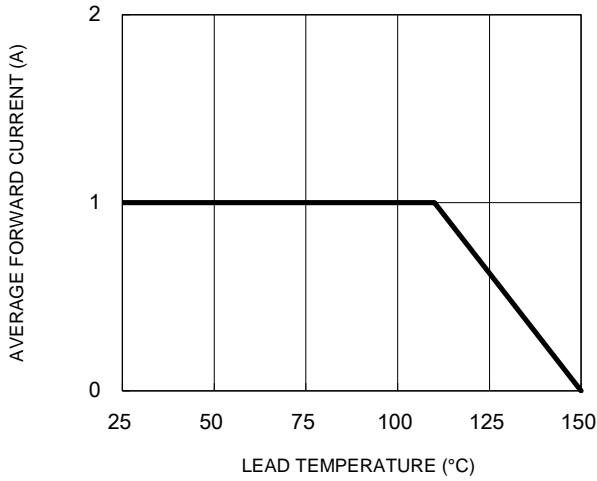

Fig.2 Typical Junction Capacitance

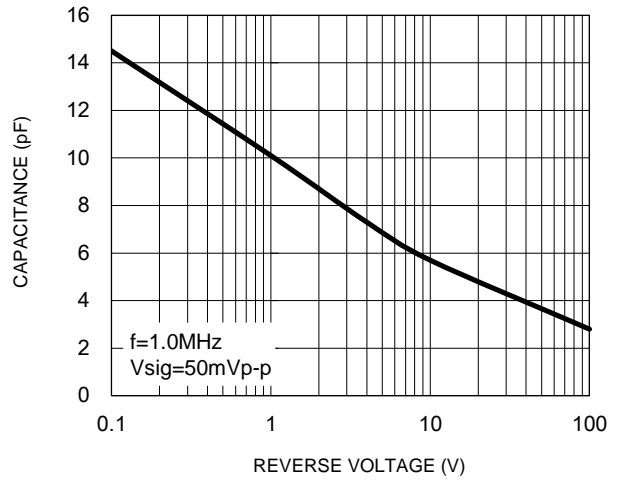

Fig.3 Typical Reverse Characteristics

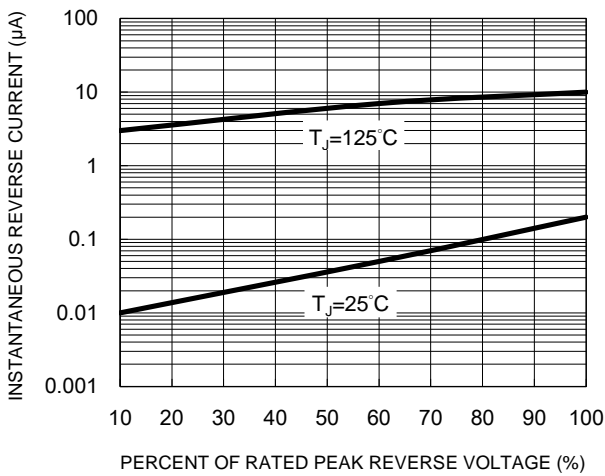

Fig.4 Typical Forward Characteristics

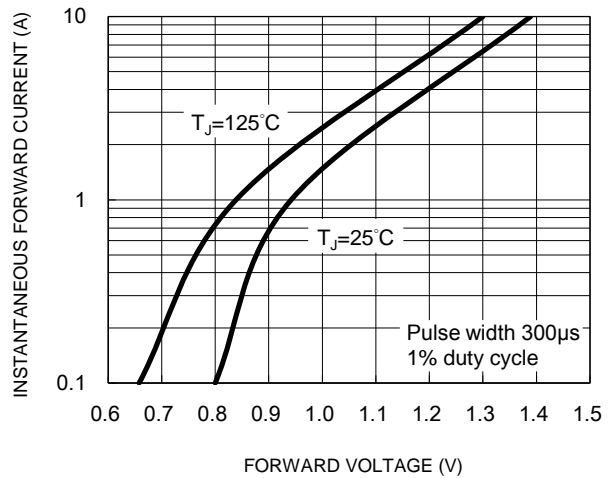
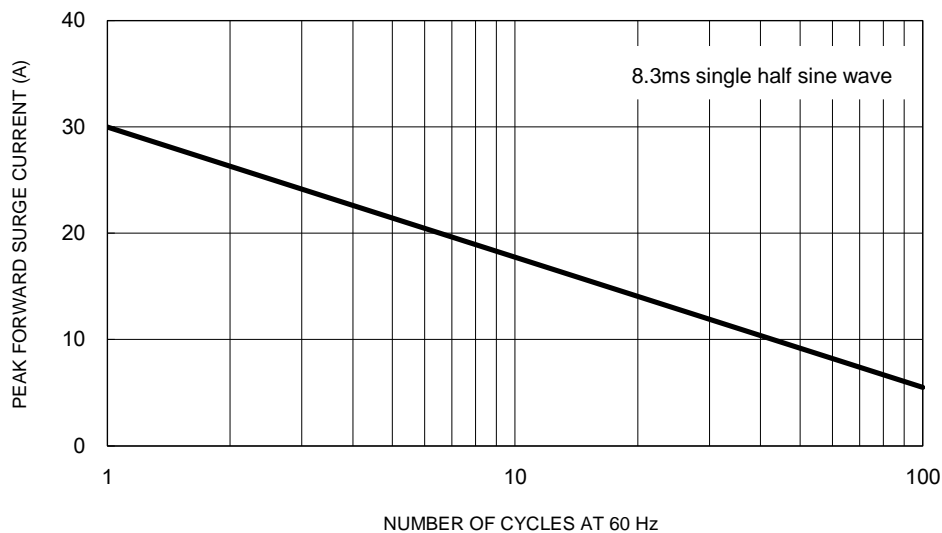

Fig.5 Maximum Non-Repetitive Forward Surge Current



CHARACTERISTICS CURVES

(T_A = 25°C unless otherwise noted)

Fig.6 Reverse Recovery Time Characteristic and Test Circuit Diagram



PACKAGE OUTLINE DIMENSIONS

SOD-123FL

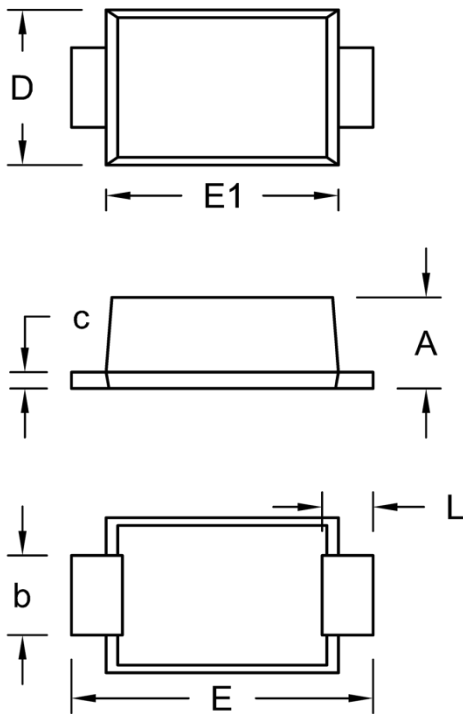

| DIM. | Unit (mm) | | Unit (inch) | |
|------|-----------|------|-------------|-------|
| | Min. | Max. | Min. | Max. |
| A | 0.88 | 1.35 | 0.035 | 0.053 |
| b | 0.80 | 1.15 | 0.031 | 0.045 |
| c | 0.10 | 0.30 | 0.004 | 0.012 |
| D | 1.70 | 2.10 | 0.067 | 0.083 |
| E | 3.45 | 3.95 | 0.136 | 0.156 |
| E1 | 2.60 | 3.10 | 0.102 | 0.122 |
| L | 0.30 | 0.90 | 0.012 | 0.035 |

SUGGESTED PAD LAYOUT

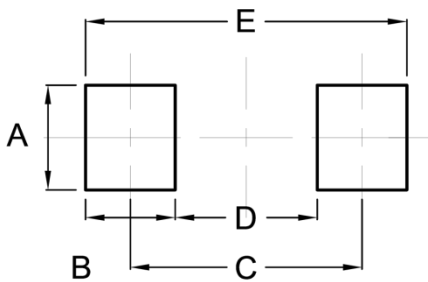

| Symbol | Unit (mm) | Unit (inch) |
|--------|-----------|-------------|
| A | 1.40 | 0.055 |
| B | 1.20 | 0.047 |
| C | 3.10 | 0.122 |
| D | 1.90 | 0.075 |
| E | 4.30 | 0.169 |

MARKING DIAGRAM



- P/N = Marking Code
- YW = Date Code
- F = Factory Code

Notice

Specifications of the products displayed herein are subject to change without notice. TSC or anyone on its behalf, assumes no responsibility or liability for any errors or inaccuracies.

Purchasers are solely responsible for the choice, selection, and use of TSC products and TSC assumes no liability for application assistance or the design of Purchasers' products.

Information contained herein is intended to provide a product description only. No license, express or implied, to any intellectual property rights is granted by this document. Except as provided in TSC's terms and conditions of sale for such products, TSC assumes no liability whatsoever, and disclaims any express or implied warranty, relating to sale and/or use of TSC products including liability or warranties relating to fitness for a particular purpose, merchantability, or infringement of any patent, copyright, or other intellectual property right.

The products shown herein are not designed for use in medical, life-saving, or life-sustaining applications. Customers using or selling these products for use in such applications do so at their own risk and agree to fully indemnify TSC for any damages resulting from such improper use or sale.

X-ON Electronics

Largest Supplier of Electrical and Electronic Components

Click to view similar products for [Rectifiers](#) category:

Click to view products by [Taiwan Semiconductor](#) manufacturer:

Other Similar products are found below :

[70HFR40](#) [RL252-TP](#) [DLA11C-TR-E](#) [DSA17G](#) [150KR30A](#) [1N5397](#) [NTE5841](#) [NTE6038](#) [SCF5000](#) [1N4002G](#) [1N4005-TR](#)
[JANS1N6640US](#) [481235F](#) [RRE02VS6SGTR](#) [067907F](#) [MS306](#) [70HF40](#) [T85HFL60S02](#) [US2JFL-TP](#) [A1N5404G-G](#) [CRS04\(T5L,TEMQ\)](#)
[ACGRA4007-HF](#) [ACGRB207-HF](#) [CLH03\(TE16L,Q\)](#) [ACGRC307-HF](#) [ACEFC304-HF](#) [NTE6356](#) [NTE6359](#) [NTE6002](#) [NTE6023](#) [NTE6039](#)
[NTE6077](#) [85HFR60](#) [40HFR60](#) [1N1186RA](#) [70HF120](#) [85HFR80](#) [D126A45C](#) [SCF7500](#) [D251N08B](#) [SCHJ22.5K](#) [SM100](#) [SCPA2](#) [SCH10000](#)
[SDHD5K](#) [VS-12FL100S10](#) [ACGRA4001-HF](#) [D1821SH45T PR](#) [D1251S45T](#) [NTE5990](#)