

SOP-8

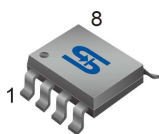

Pin assignment:

- | | |
|----------|-----------|
| 1. Drain | 8. Ground |
| 2. Drain | 7. Ground |
| 3. Drain | 6. Ground |
| 4. Vdd | 5. Ground |

General Description

The TS19452 is a PWM high efficiency LED driver control IC. It allows efficient operation of LED strings from voltage source ranging up to 450VDC. It includes an internal high voltage switching MOSFET controlled with fixed off-time of approximately 12 μ S.

The LED string is driven at constant current, thus providing constant light output and enhanced reliability. The output current is internally fixed at 100mA. The peak current control scheme provides good regulation of the output current throughout the universal AC line voltage range of 85~264VAC or DC input voltage of 20~400V

Features

- Constant output current at 100mA(typ)
- Universal 85~264VAC operation
- Fixed off-time buck converter
- Internal 475V power MOSFET
- Low inductance value at 4.7mH (typ)

Application

- Decorating LED lighting
- LED lamps with AC or DC operation.

Ordering Information

Part No.	Package	Packing
TS19452CS RLG	SOP-8	2.5Kpcs / 13" Reel

Note: "G" denote for Halogen Free Product

Typical Application Circuit

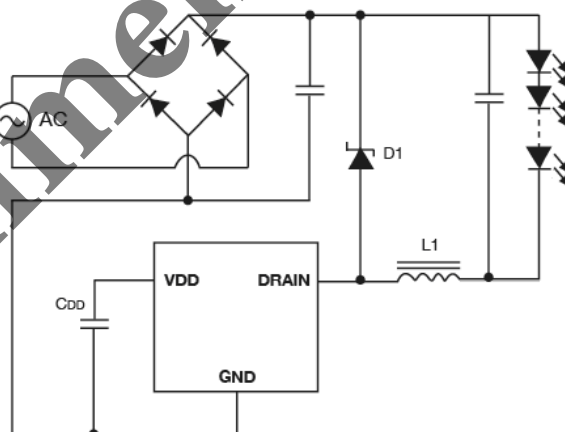

Absolute Maximum Rating

Parameter	Symbol	Limit	Unit
Input Voltage Range	V_{IN} to GND	~ +475	V
Supply Current	I_{DD}	400	μ A
Power Dissipation @ $T_A=25^\circ\text{C}$	P_D	2500	mW
Operating Ambient Temperature	T_{OPR}	-40 to +85	$^\circ\text{C}$
Storage Temperature Range	T_{STG}	-65 to +150	$^\circ\text{C}$
Junction Temperature Range	T_J	-40 to +150	$^\circ\text{C}$
Thermal Resistance – Junction to Ambient	$R\theta_{JA}$	65	$^\circ\text{C/W}$

Note: Stresses beyond those listed under "Absolute Maximum Ratings" may cause permanent damage to the device. These are stress rating only, and functional operation of the device at these or any other conditions beyond those indicated in the operational sections of the specifications is not implied. Exposure to absolute maximum rating conditions for extended periods may affect device reliability.

Electrical Specifications (Ta = 25°C, V_{DRAIN} = 50V, unless otherwise noted)

Function Parameter	Symbol	Test Conditions	Min	Typ	Max	Units
Internal Regulator						
Internally Regulated Voltage	V _{DD}		--	7.5	--	V
Drain Supply Voltage	V _{DRAIN}		20	--	450	V
Undervoltage Lockout Threshold	UVLO	V _{DD} rising	5	--	--	V
Undervoltage Lockout Hysteresis	ΔUVLO	V _{DD} falling	--	200	--	mV
Supply Current	I _{DD}	V _{DD(EXT)} =8.5V, V _{DRAIN} =40V	--	--	400	μA
Output (Drain)						
Breakdown Voltage	V _{BR}	Note 1	550	--	--	V
On Resistance	R _{DSON}	I _{DRAIN} =100mA	--	--	100	Ω
Output Capacitance	C _{DRAIN}	V _{DRAIN} =400V	--	1.0	5.0	pF
MOSFET Saturation current	I _{SAT}		--	--	120	mA
Current Sense Comparator						
Threshold Current	I _{TH}	Note 1	90	--	110	mA
Leading edge Blanking delay	T _{BLANK}	Note 1,2	200	300	400	nS
Minimum Turn On-Time	T _{ON(MIN)}		--	--	650	nS
Off-Time Generator						
Turn On-Time	T _{OFF}		8	12	18	μS

Note 1: The specification which apply over the full operating ambient temperature range of -40°C < T_A < +85°C

2: Guaranteed by design

Block Diagram

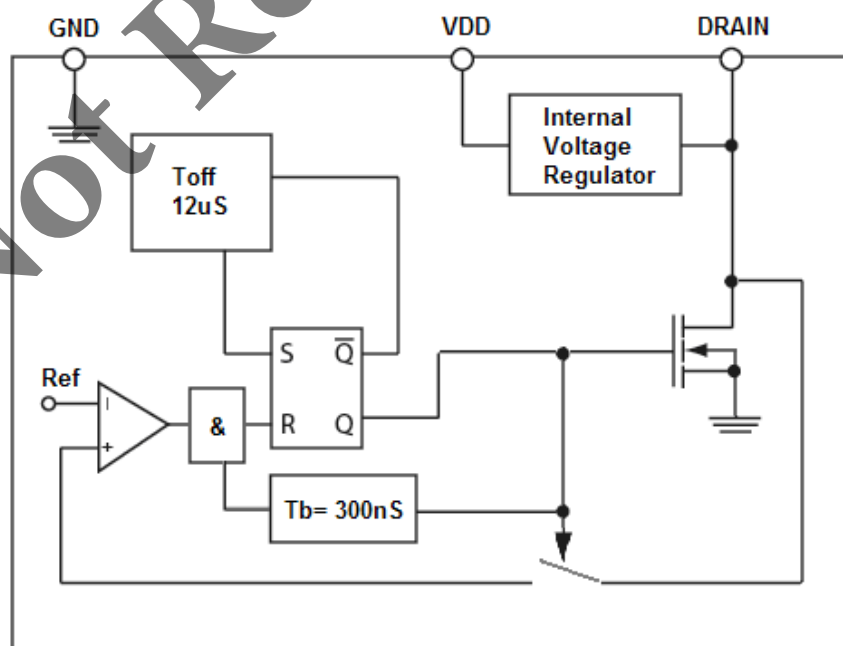

Function Description

The TS19452 is a PWM peak current controller for controlling a buck converter topology in continuous conduction mode (CCM). The output current is internally preset at 100mA

When the input voltage of 20~400V appears at the Drain pin, the internal high-voltage linear regulator seeks to maintain a voltage of 7.5VDC at the VDD pin. Until this voltage exceeds the internally programmed under-voltage threshold, the output switching MOSFET is non-conductive. When the threshold is exceeded, the MOSFET turns on. The input current begins to flow into the Drain pin. Hysteresis is provided in the under-voltage comparator to prevent oscillation.

When the input current exceeds the internal preset level, a current sense comparator resets an RS flip-flop, and the MOSFET turns off. At the same time, a one-shot circuit is activated that determines the duration of the off-state (12µS typ.) As soon as this time is over, the flip-flop sets again. The new switching cycle begins.

A “blanking” delay of 300nS is provided that prevents false triggering of the current sense comparator due to the leading edge spike caused by circuit parasitic.

Application Information

The TS19452 is specifically designed for driving multi LED strings. It can be operated from either universal AC line range of 85~264VAC or 20~400VDC, and drives up to tens of high brightness LEDs. All LEDs can be run in series and this device regulates at constant current, yielding uniform illumination.

Selecting L1 and D1

There is a certain trade-off to be considered between optimal sizing of the output inductor L1 and the tolerated output current ripple. The required value of L1 is inversely proportional to the ripple current ΔI_O in it.

$$L1 = (V_O \times T_{OFF}) / \Delta I_O$$

V_O is the forward voltage of the LED string. T_{OFF} is the off-time of the TS19452. The output current in the LED string (I_O) is calculated as:

$$I_O = I_{TH} - (\Delta I_O / 2)$$

Where I_{TH} is the current sense comparator threshold. The ripple current introduces a peak-to-average error in the output current setting that needs to be accounted for. Due to constant off-time control technique used in the TS19452, the ripple current is independent of the input AC or DC line voltage variation. Therefore, the output current will remain unaffected by the varying input voltage.

According a filter capacitor across the LED string can reduce the output current ripple even further, thus permitting a reduced value of L1. However, one must keep in mind that the peak-to-average current error is affected by the variation of T_{OFF} . Therefore, the initial output current accuracy might be sacrificed at large ripple current in L1.

Another important aspect of designing an LED driver with TS19452 is related to certain parasitic elements of the circuit, including distributed coil capacitance of L1, junction capacitance and reverse recover of the rectifier diode D1, capacitance of the PCB traces C_{PCB} and output capacitance C_{DRAIN} of the controller itself. These parasitic elements affect the efficiency of the switching converter and could potentially cause false triggering of the current sense comparator if not properly managed. Minimizing these parasitic is essential for efficient and reliable operation of the TS19452.

Coil capacitance of inductors is typically provided in the manufacturer's data books either directly or in terms of the self-resonant frequency (SRF).

$$SRF = 1 / (2\pi \cdot \sqrt{L \cdot CL})$$

Application Information (Continue)

Where L is the inductance value, and C_L is the coil capacitance. Charging and discharging this capacitance every switching cycle causes high-current spikes in the LED string. Therefore, connecting a small capacitor C_O (~100nF) is recommended to bypass these spikes.

Using an ultra-fast rectifier diode for D1 is recommended to achieve high efficiency and reduce the risk of false triggering of the current sense comparator. Using diodes with shorter reverse recovery time t_{rr} and lower junction capacitance C_J achieves better performance. The reverse voltage rating V_R of the diode must be greater than the maximum input voltage of LED lamps.

The total parasitic capacitance present at the Drain pin of the TS19452 can be calculated as:

$$C_P = C_{DRAIN} + C_{PCB} + C_L + C_J$$

When the switching MOSFET turns on, the capacitance C_P is discharged into the Drain pin of the IC. The discharge current is limited to about 150mA typically. However, it may become lower at increased junction temperature. The duration of the leading edge current spike can be estimated as:

$$T_{PSIKE} = ((V_{IN} \times C_P) / (I_{SAT})) + t_r$$

EMI Filter

As with all off-line converters, selecting an input filter is critical to obtaining good EMI. A switching side capacitor, albeit of small value, is necessary in order to ensure low impedance to the high frequency switching currents of the converter. As a rule of thumb, this capacitor should be approximately 0.1~0.2 μ F/W of LED output power.

Not Recommended

Electrical Characteristics Curve

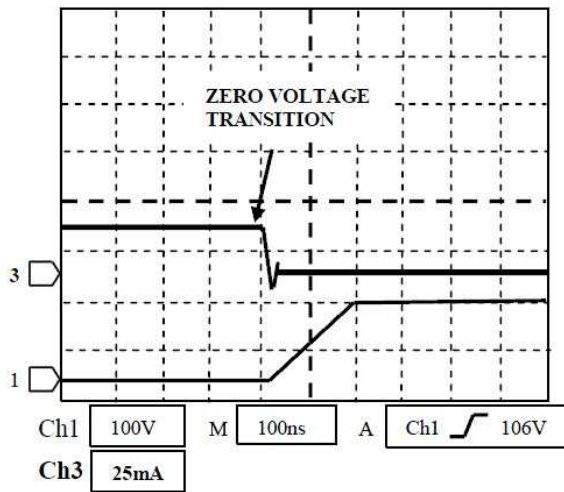

Figure 1. Switch-Off Transition
Ch1: V_{DRAIN} , Ch3: I_{DRAIN}

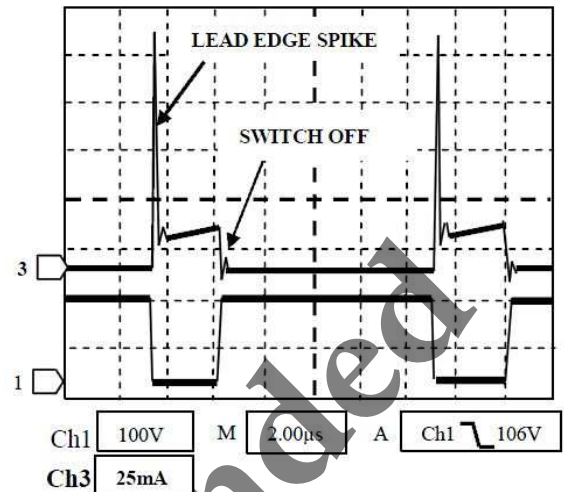

Figure 2. Switch-On Transition
Ch1: V_{DRAIN} , Ch3: I_{DRAIN}

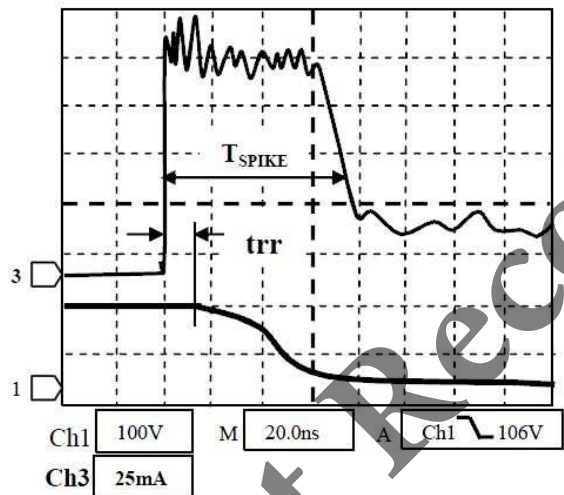
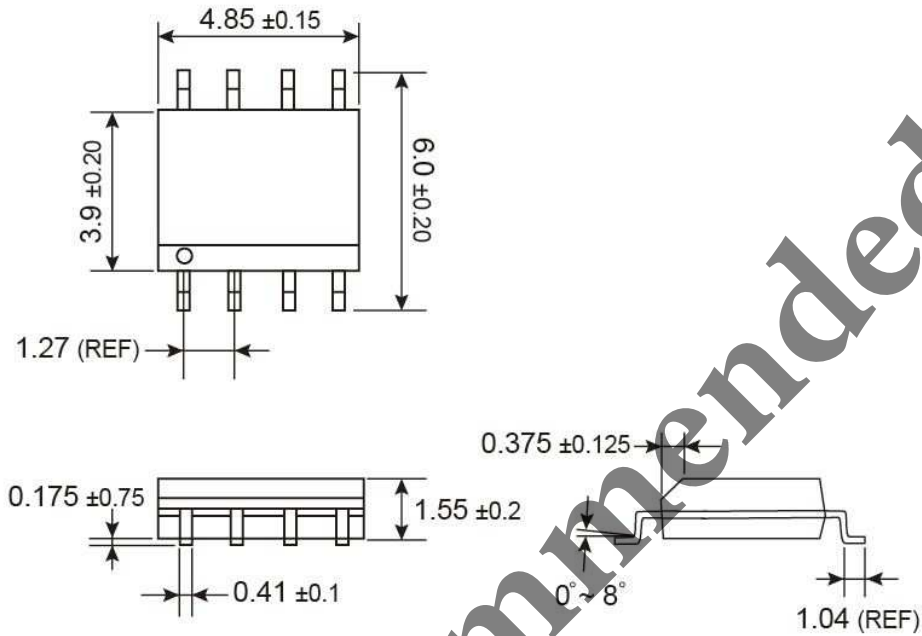

Figure 3. Lead Edge Spike
Ch1: V_{DRAIN} , Ch3: I_{DRAIN}

SOP-8 Mechanical Drawing



Unit: Millimeters

Marking Diagram

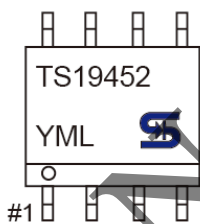

- Y** = Year Code
- M** = Month Code for Halogen Free Product
(O=Jan, P=Feb, Q=Mar, R=Apr, S=May, T=Jun, U=Jul, V=Aug, W=Sep, X=Oct, Y=Nov, Z=Dec)
- L** = Lot Code

Not Recommended

Notice

Specifications of the products displayed herein are subject to change without notice. TSC or anyone on its behalf, assumes no responsibility or liability for any errors or inaccuracies.

Information contained herein is intended to provide a product description only. No license, express or implied, to any intellectual property rights is granted by this document. Except as provided in TSC's terms and conditions of sale for such products, TSC assumes no liability whatsoever, and disclaims any express or implied warranty, relating to sale and/or use of TSC products including liability or warranties relating to fitness for a particular purpose, merchantability, or infringement of any patent, copyright, or other intellectual property right.

The products shown herein are not designed for use in medical, life-saving, or life-sustaining applications. Customers using or selling these products for use in such applications do so at their own risk and agree to fully indemnify TSC for any damages resulting from such improper use or sale.

X-ON Electronics

Largest Supplier of Electrical and Electronic Components

Click to view similar products for [LED Lighting Drivers](#) category:

Click to view products by [Taiwan Semiconductor](#) manufacturer:

Other Similar products are found below :

[LV5235V-MPB-H](#) [MB39C602PNF-G-JNEFE1](#) [MIC2871YMK-T5](#) [AL1676-10BS7-13](#) [AL1676-20AS7-13](#) [AP5726WUG-7](#) [ICL8201](#)
[IS31BL3228B-UTLS2-TR](#) [IS31BL3506B-TTLS2-TR](#) [AL3157F-7](#) [LV52204MTTBG](#) [AP5725WUG-7](#) [STP4CMPQTR](#) [NCL30086BDR2G](#)
[CAT4004BHU2-GT3](#) [LV52207AXA-VH](#) [AP1694AS-13](#) [TLE4242EJ](#) [AS3688](#) [IS31LT3172-GRLS4-TR](#) [TLD2311EL](#) [KTD2694EDQ-TR](#)
[KTZ8864EJAA-TR](#) [IS32LT3174-GRLA3-TR](#) [MP2488DN-LF-Z](#) [NLM0010XTSA1](#) [AL1676-20BS7-13](#) [ZXLD1370QESTTC](#) [MPQ7220GF-](#)
[AEC1-P](#) [MPQ7220GR-AEC1-P](#) [MPQ4425BGJ-AEC1-P](#) [MPQ7220GF-AEC1-Z](#) [MPQ7220GR-AEC1-Z](#) [MPQ4425BGJ-AEC1-Z](#)
[IS31FL3737B-QFLS4-TR](#) [IS31FL3239-QFLS4-TR](#) [KTD2058EUAC-TR](#) [KTD2037EWE-TR](#) [DIO5662ST6](#) [IS31BL3508A-TTLS2-TR](#)
[KTD2026BEWE-TR](#) [MAX20052CATC/V+](#) [MAX25606AUP/V+](#) [BD6586MUV-E2](#) [BD9206EFV-E2](#) [LYT4227E](#) [LYT6079C-TL](#)
[MP3394SGF-P](#) [MP4689AGN-P](#) [MPQ4425AGQB-AEC1-Z](#)