

SOP-8

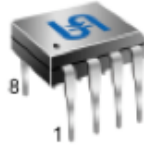

DIP-8



Pin assignment:

- | | |
|----------------|----------------|
| 1. Output A | 8. Vcc |
| 2. Input A (-) | 7. Output B |
| 3. Input A (+) | 6. Input B (-) |
| 4. Gnd | 5. Input B (+) |

General Description

Utilizing the circuit designs perfected for recently introduced Quad Operational Amplifiers, these dual operational amplifiers have several distinct advantages over standard operational amplifier types in single supply applications. They can operate at supply voltages as low as 3.0 Volts or as high as 32 Volts with quiescent currents about one fifth of those associated with the LM741 (on a per amplifier basis). The common mode input range includes the negative supply, thereby eliminating the necessity for external biasing components in many applications. The TS358 is equivalent to one half of TS324, and output voltage range also includes the negative supply voltage.

Features

- Short circuit protected outputs
- True differential input stage
- Single supply operation: 3V to 32V
- Low input bias currents
- Internally compensated
- Common mode range extends to negative supply
- Single and split supply operation
- Similar performance to the popular MC1558

Block Diagram

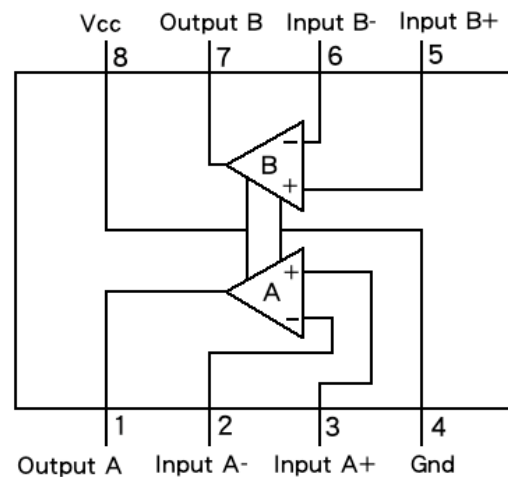

Ordering Information

Part No.	Package	Packing
TS358CD C3	DIP-8	50pcs / Tube
TS358CS RL	SOP-8	2.5Kpcs / 13" Reel

Absolute Maximum Rating

Parameter	Symbol	Limit	Unit
Supply Voltage	V _{CC}	+32 or ±16	V
Differential Input Voltage (Split Power Supplies)	V _{IDR}	32	V
Input Common Mode Voltage Range (note 1)	V _{ICR}	-0.3 to 32	V
Input Forward Current (note 2)	I _{IF}	50	mA
Output Short Circuit Duration	t _{SC}	Continuous	
Operating Junction Temperature Range	T _J	0 ~ +70	°C
Storage Temperature Range	T _{STG}	-65 ~ +150	°C

Note 1: For supply, voltages less than 32V for the TS358 the absolute maximum input voltage is equal to the supply voltage.

Note 2: This input current will only exist when the voltage is negative at any of the input leads. Normal output states will reestablish when the input voltage returns to a voltage greater than -0.3V.

Electrical Characteristics ($V_{CC} = 5V$, $T_a = 25^\circ C$; unless otherwise specified.)

Characteristics	Symbol	Min	Typ	Max	Unit
Input Offset Voltage $V_{CC} = 5.0V$ to $30V$, $V_{IC} = 0V$ to $V_{CC} - 1.7V$, $V_O = 1.4V$, $R_S = 0\Omega$ $T_{LOW} \leq T_a \leq T_{HIGH}$	V_{IO}	--	2.0	7.0	mV
Average Temperature Coefficient of Input Offset Voltage	$\Delta I_{IO}/\Delta T$	--	7.0	--	$\mu V/^\circ C$
Input Offset Current $T_{LOW} \leq T_a \leq T_{HIGH}$	I_{IO}	--	5.0	50	nA
Average Temperature Coefficient of input Offset Current	$\Delta I_{IO}/\Delta T$	--	10	--	$\mu A/^\circ C$
Input Bias Current $T_{LOW} \leq T_a \leq T_{HIGH}$	I_{IB}	--	-45	-250	nA
Input Common-Mode Voltage Range) $V_{CC} = 30V$ (Note1) $V_{CC} = 30V$, $T_{LOW} \leq T_a \leq T_{HIGH}$	V_{ICR}	0	--	28.3	V
Differential Input Voltage Range	V_{IDR}	--	--	V_{CC}	V
Large Signal Open-Loop Voltage Gain $R_L = 2.0K$, $V_{CC} = 15V$, For Large V_O Swing, $T_{LOW} \leq T_a \leq T_{HIGH}$	A_{VOL}	25	100	--	V/mV
Channel Separation 1.0 KHz to 20KHz	--	--	-120	--	dB
Common Mode Rejection Ratio $R_S \leq 10k\Omega$	CMRR	65	70	--	dB
Power Supply Rejection Ratio	PSRR	65	100	--	dB
Output Voltage Range, $R_L = 2K\Omega$	V_{OR}	0	--	3.3	V
Output Voltage -- High Limit $V_{CC} = 30V$, $R_L = 2k\Omega$ $V_{CC} = 30V$, $R_L = 10k\Omega$	V_{OH}	26	--	--	V
Output Voltage -- Low Limit $V_{CC} = 5.0V$, $R_L = 10k\Omega$	V_{OL}	--	5.0	20	mV
Output Source Current $V_{ID} = +1.0V$, $V_{CC} = 15V$	I_{O+}	20	40	--	mA
Output Sink Current $V_{ID} = -1.0V$, $V_{CC} = 15V$ $V_{ID} = -1.0V$, $V_O = 200mV$	I_{O-}	10	20	--	mA
Output Short Circuit to Ground (Note 2)	I_{OS}	--	40	60	mA
Power Supply Current , $V_{CC} = 30V$, $V_O = 0V$, $R_L = \infty$ $V_{CC} = 5.0V$, $V_O = 0V$, $R_L = \infty$	I_{CC}	--	1.5	3.0	mA
		--	0.7	1.2	

Notes :

1. The input common mode voltage or either input signal voltage should not be allowed to go negative by more than 0.3 V. The upper end of the common mode voltage range is $V_{CC} - 17V$, but either or both inputs can go to $+32V$.
2. Short circuits from the output to V_{CC} can cause excessive heating and eventual destruction. Destructive dissipation can result from simultaneous shorts on all amplifiers.

Electrical Characteristics Curve ($T_A=25^\circ\text{C}$; unless otherwise specified.)

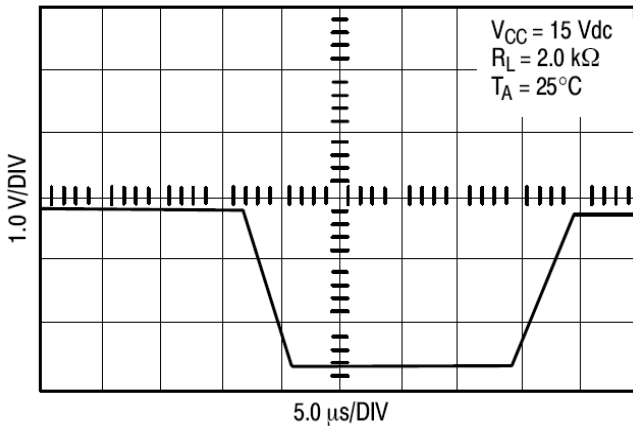

Figure 1. Large Signal Voltage Follower Response

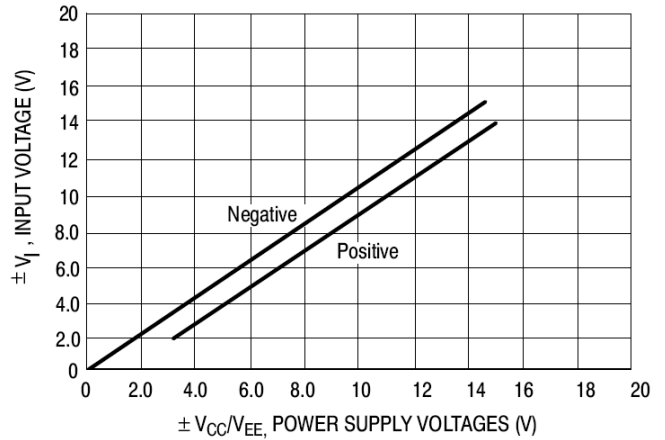

Figure 2. Input Voltage Range

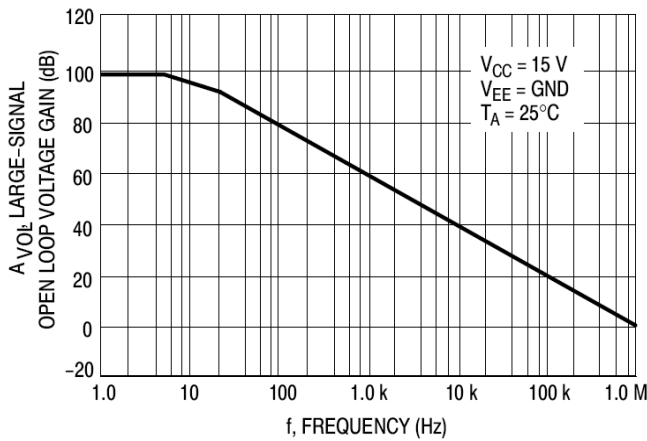

Figure 3. Open Loop Frequency

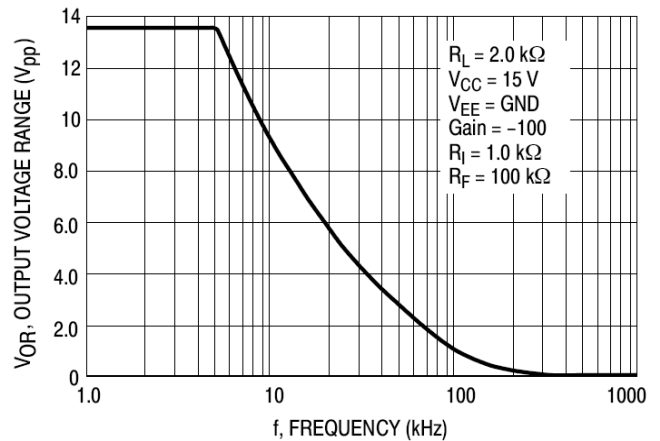

Figure 4. Large Signal Frequency Response

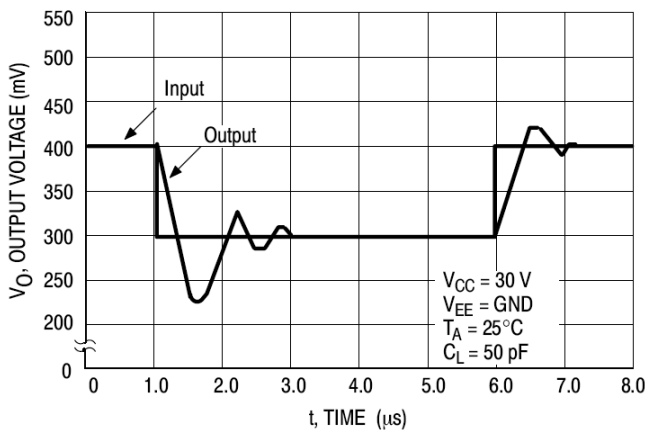

Figure 5. Small-Signal Voltage Follower Pulse Response (Noninverting)

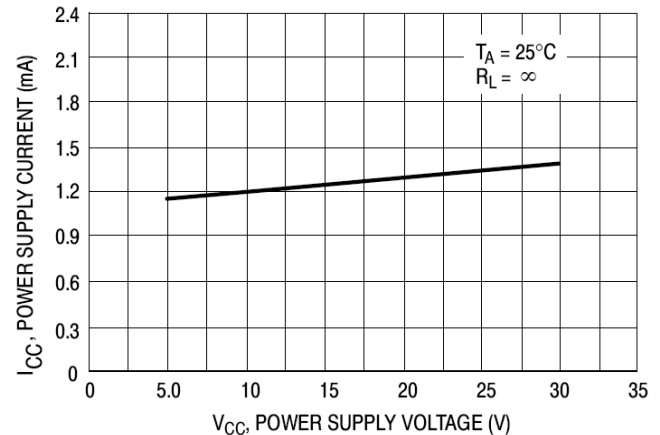

Figure 6. Power Supply Current vs. Supply Voltage

Application Description

The TS358 made using two internally compensated, two-stage operational amplifiers. The first stage performs not only the first stage gain function but also performs the level shifting and transconductance reduction functions. By reducing the transconductance, a smaller compensation capacitor (only 5.0pF) can be employed, thus saving chip area. Another feature of this input stage is that the input common mode range can include the negative supply or ground, in single supply operation, without saturating either the input devices or the differential to single-ended converter. The second stage consists of a standard current source load amplifier stage.

Each amplifier is biased from an internal-voltage regulator, and which has a low temperature coefficient thus giving each amplifier good temperature characteristics as well as excellent power supply rejection.

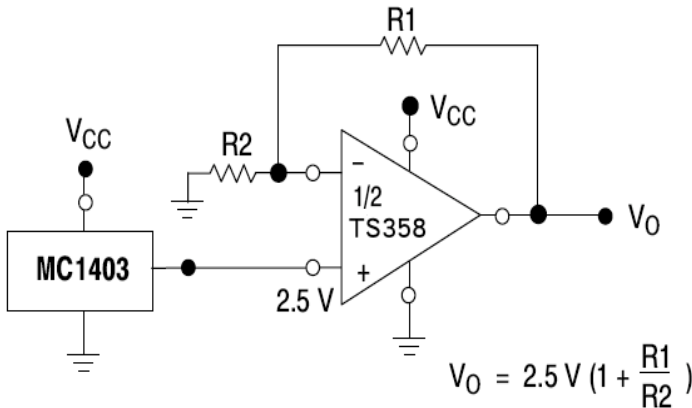

Figure 7. Voltage Reference

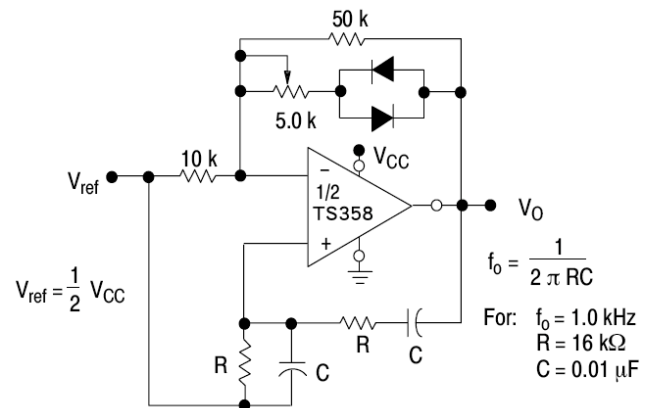

Figure 8. Wien Bridge Oscillator

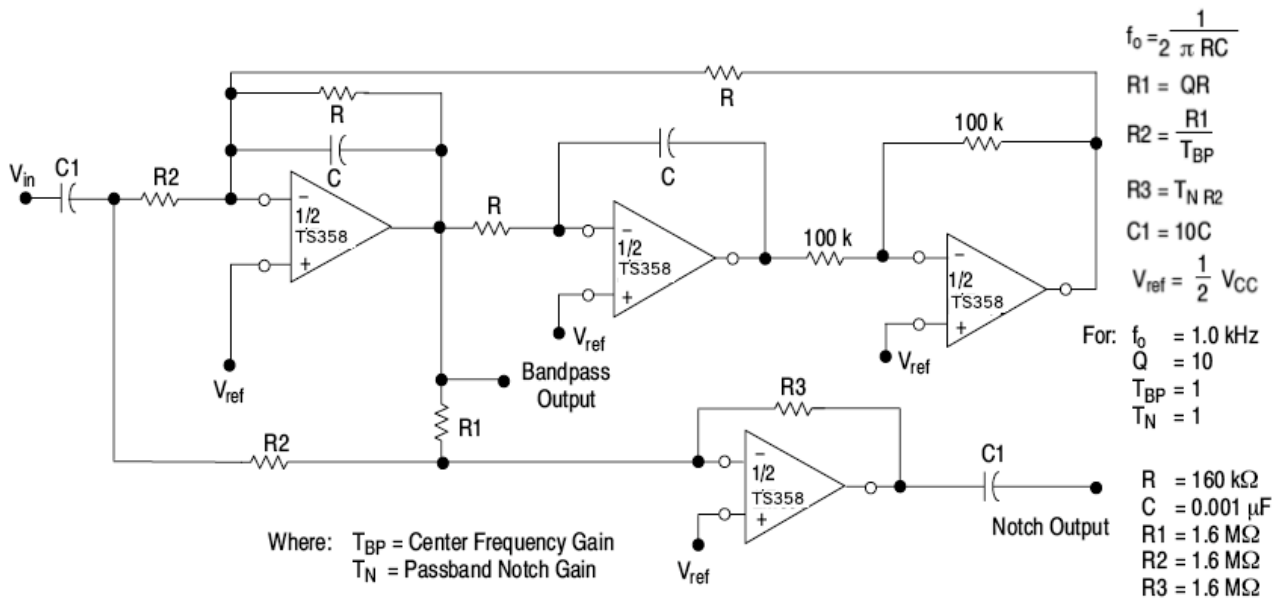

Figure 9. Bi-Quad Filter

Application Description (Continue)

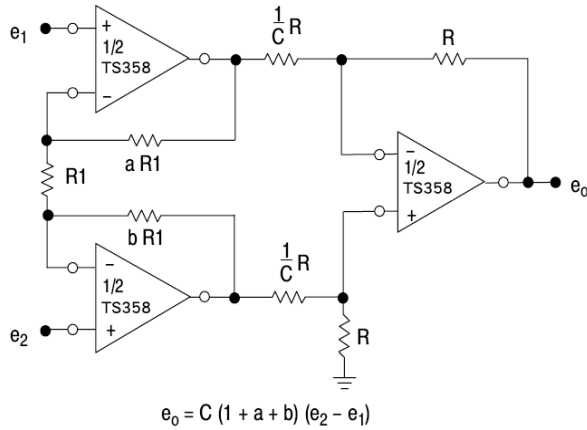

Figure 10. High Impedance Differential Amplifier

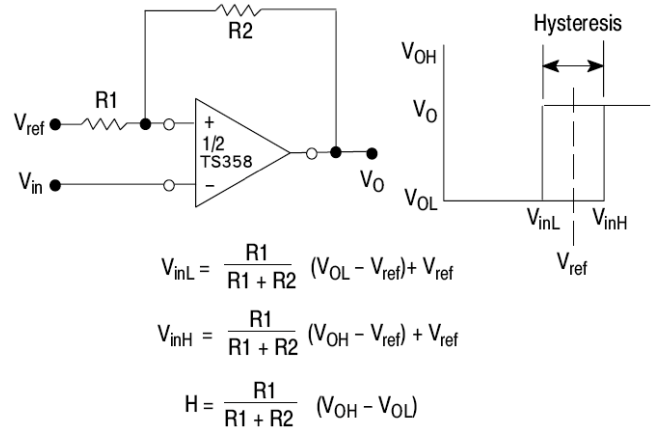

Figure 11. Comparator with Hysteresis

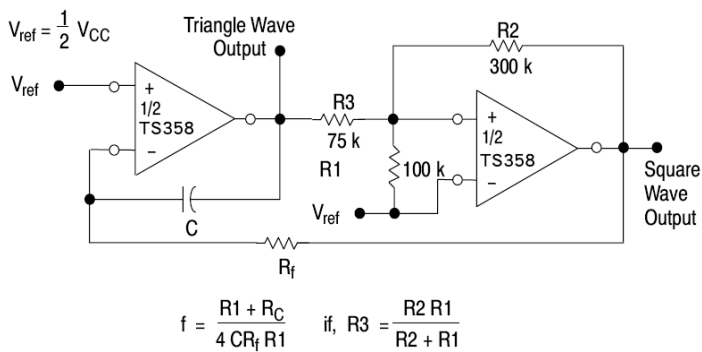
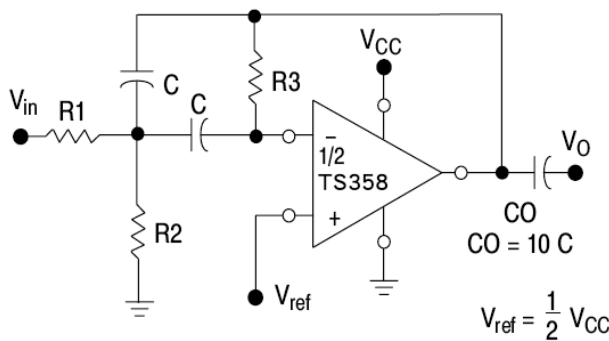

Figure 12. Function Generator



Given: f_0 = center frequency
 $A(f_0)$ = gain at center frequency

Choose value f_0, C

Then: $R3 = \frac{Q}{\pi f_0 C}$
 $R1 = \frac{R3}{2 A(f_0)}$
 $R2 = \frac{R1 R3}{4 Q^2 R1 - R3}$

For less than 10% error from operational amplifier. $\frac{Q_0 f_0}{BW} < 0.1$

Where f_0 and BW are expressed in Hz.

If source impedance varies, filter may be preceded with voltage follower buffer to stabilize filter parameters.

Figure 13. Multiple Feedback Bandpass Filter

SOP-8 Mechanical Drawing

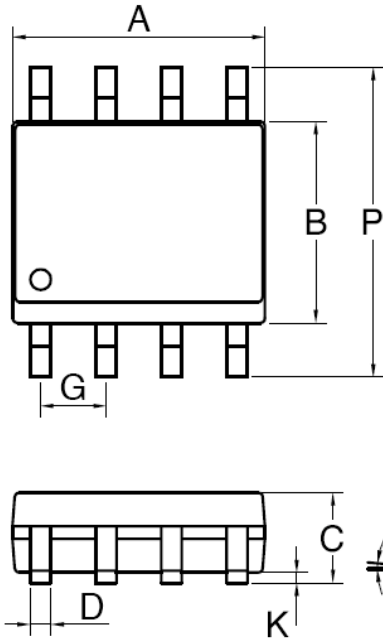

DIM	MILLIMETERS		INCHES	
	MIN	MAX	MIN	MAX.
A	4.80	5.00	0.189	0.196
B	3.80	4.00	0.150	0.157
C	1.35	1.75	0.054	0.068
D	0.35	0.49	0.014	0.019
F	0.40	1.25	0.016	0.049
G	1.27BSC		0.05BSC	
K	0.10	0.25	0.004	0.009
M	0°	7°	0°	7°
P	5.80	6.20	0.229	0.244
R	0.25	0.50	0.010	0.019

Marking Diagram

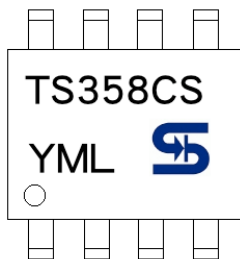

- Y** = Year Code
- M** = Month Code
(**A**=Jan, **B**=Feb, **C**=Mar, **D**=Apr, **E**=May, **F**=Jun, **G**=Jul, **H**=Aug, **I**=Sep, **J**=Oct, **K**=Nov, **L**=Dec)
- L** = Lot Code

DIP-8 Mechanical Drawing

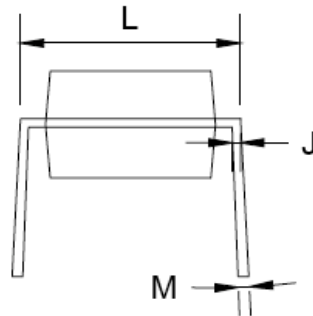
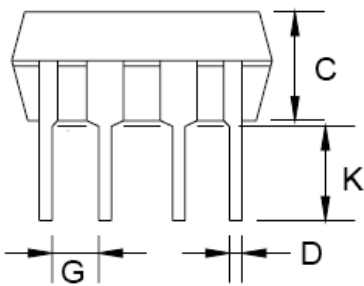
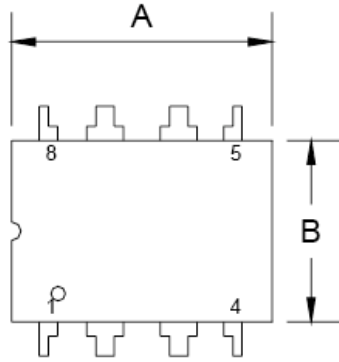

DIP-8 DIMENSION				
DIM	MILLIMETERS		INCHES	
	MIN	MAX	MIN	MAX
A	9.07	9.32	0.357	0.367
B	6.22	6.48	0.245	0.255
C	3.18	4.45	0.125	0.135
D	0.35	0.55	0.019	0.020
G	2.54 (typ)		0.10 (typ)	
J	0.29	0.31	0.011	0.012
K	3.25	3.35	0.128	0.132
L	7.75	8.00	0.305	0.315
M	-	10°	-	10°

Marking Diagram

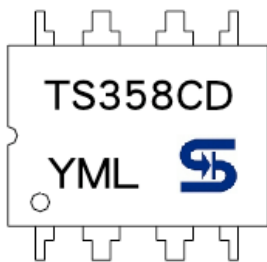

- Y** = Year Code
- M** = Month Code
(A=Jan, B=Feb, C=Mar, D=Apl, E=May, F=Jun, G=Jul, H=Aug, I=Sep, J=Oct, K=Nov, L=Dec)
- L** = Lot Code

Notice

Specifications of the products displayed herein are subject to change without notice. TSC or anyone on its behalf, assumes no responsibility or liability for any errors or inaccuracies.

Information contained herein is intended to provide a product description only. No license, express or implied, to any intellectual property rights is granted by this document. Except as provided in TSC's terms and conditions of sale for such products, TSC assumes no liability whatsoever, and disclaims any express or implied warranty, relating to sale and/or use of TSC products including liability or warranties relating to fitness for a particular purpose, merchantability, or infringement of any patent, copyright, or other intellectual property right.

The products shown herein are not designed for use in medical, life-saving, or life-sustaining applications. Customers using or selling these products for use in such applications do so at their own risk and agree to fully indemnify TSC for any damages resulting from such improper use or sale.

X-ON Electronics

Largest Supplier of Electrical and Electronic Components

Click to view similar products for [Operational Amplifiers - Op Amps](#) category:

Click to view products by [Taiwan Semiconductor](#) manufacturer:

Other Similar products are found below :

[OPA2991IDSGR](#) [OPA607IDCKT](#) [007614D](#) [633773R](#) [635798C](#) [635801A](#) [702115D](#) [709228FB](#) [741528D](#) [NCV33072ADR2G](#)
[SC2902DTBR2G](#) [SC2903DR2G](#) [SC2903VDR2G](#) [LM258AYDT](#) [LM358SNG](#) [430227FB](#) [430228DB](#) [460932C](#) [AZV831KTR-G1](#) [409256CB](#)
[430232AB](#) [LM2904DR2GH](#) [LM358YDT](#) [LT1678IS8](#) [042225DB](#) [058184EB](#) [070530X](#) [SC224DR2G](#) [SC239DR2G](#) [SC2902DG](#)
[SCYA5230DR2G](#) [714228XB](#) [714846BB](#) [873836HB](#) [MIC918YC5-TR](#) [TS912BIYDT](#) [NCS2004MUTAG](#) [NCV33202DMR2G](#)
[M38510/13101BPA](#) [NTE925](#) [SC2904DR2G](#) [SC358DR2G](#) [LM358EDR2G](#) [AZV358MTR-G1](#) [AP4310AUMTR-AG1](#) [HA1630D02MMEL-E](#)
[NJM358CG-TE2](#) [HA1630S01LPEL-E](#) [LM324AWPT](#) [HA1630Q06TELL-E](#)