

## Miniature Bipolar Capacitors for Audio

GREEN CAP For Audio

- The newly developed audio use foil and special electrolyte makes clear and far-carrying sound a reality.
- All lead wires are copper plated steel wires.

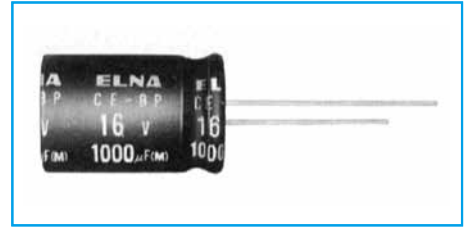
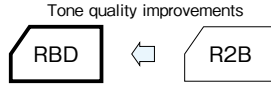

Marking color : Gold print on a black sleeve

### Specifications

Item	Performance									
Category temperature range (°C)	-40 to +85									
Tolerance at rated capacitance (%)	±20 (20°C, 120Hz)									
Leakage current (µA) (max.)	0.03CV + 3 (after 5 minutes) C : Rated capacitance (µF); V : Rated voltage (V) (20°C)									
Tangent of loss angle (tanδ)	Rated voltage (V)	6.3	10	16	25	35	50	63	100	
	tanδ (max.)	0.24	0.20	0.16	0.15	0.14	0.12	0.10	0.09	
0.02 is added to every 1000µF increase over 1000µF. (20°C, 120Hz)										
Characteristics at high and low temperature	Rated voltage (V)	6.3	10	16	25	35	50	63	100	
	Impedance ratio (max.)	Z-25°C/Z+20°C	4	3	2	2	2	2	2	2
		Z-40°C/Z+20°C	10	8	6	4	3	3	3	3
0.5 for -25°C, 1 for -40°C are added to every 1000µF increase over 1000µF. (120Hz)										
Endurance (85°C) (Applied ripple current)	Test time	2000 hours (with the polarity inverted every 250 hours)								
	Leakage current	The initial specified value or less								
	Percentage of capacitance change	Within ±20% of initial value								
	Tangent of the loss angle	150% or less of the initial specified value								
Applicable standards	JIS C5101-1, -4 (IEC 60384-1, -4)									

### Outline Drawing

Unit : mm

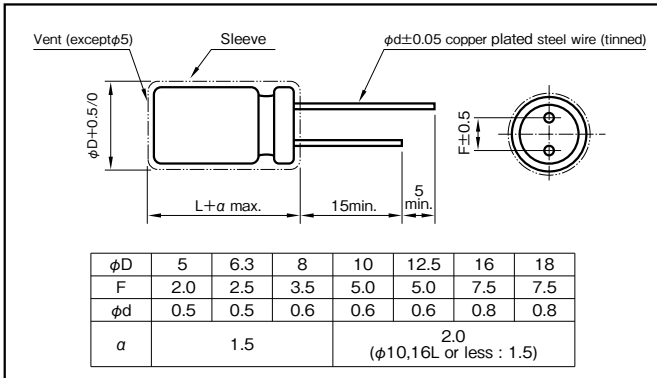

### Coefficient of Frequency for Rated Ripple Current

Frequency (Hz)	50 - 60	120	1k	10k · 100k
Rated voltage (V)				
6.3 to 16	0.8	1	1.1	1.2
25 to 35	0.8	1	1.5	1.7
50 to 100	0.8	1	1.6	1.9

### Part numbering system (example : 10V1000µF)



### Case symbol

Case φD×L (mm)	Casing Symbol	Case φD×L (mm)	Casing Symbol	Case φD×L (mm)	Casing Symbol	Case φD×L (mm)	Casing Symbol
5×11	E3	10×12.5	H3	12.5×20	I5	16×31.5	J7
6.3×11	F3	10×16	H4	12.5×25	I6	18×35.5	K8
8×11.5	G3	10×20	H5	16×25	J6	—	—

### Standard Ratings

Rated voltage (V)	6.3		10		16		25		35		50		63		100		
	Item	Case φD×L (mm)	Rated ripple current (mA)	Case φD×L (mm)	Rated ripple current (mA)	Case φD×L (mm)	Rated ripple current (mA)	Case φD×L (mm)	Rated ripple current (mA)	Case φD×L (mm)	Rated ripple current (mA)	Case φD×L (mm)	Rated ripple current (mA)	Case φD×L (mm)	Rated ripple current (mA)	Case φD×L (mm)	Rated ripple current (mA)
1	—	—	—	—	—	—	—	—	—	—	—	—	—	—	—	—	—
2.2	—	—	—	—	—	—	—	—	—	—	—	—	—	—	—	—	—
3.3	—	—	—	—	—	—	—	—	—	—	—	—	—	—	—	—	—
4.7	—	—	—	—	—	—	—	5×11	28	5×11	28	5×11	31	5×11	34	6.3×11	41
10	—	—	—	—	5×11	39	5×11	40	5×11	42	5×11	45	6.3×11	57	8×11.5	70	
22	—	—	—	5×11	52	5×11	58	5×11	60	6.3×11	71	6.3×11	77	8×11.5	89	10×16	136
33	5×11	58	5×11	63	5×11	71	6.3×11	84	6.3×11	87	8×11.5	111	10×12.5	144	10×20	181	
47	5×11	69	5×11	75	6.3×11	97	6.3×11	100	8×11.5	122	10×12.5	157	10×16	188	12.5×20	248	
100	6.3×11	115	6.3×11	126	8×11.5	167	10×12.5	204	10×12.5	212	10×20	273	12.5×20	343	16×25	458	
220	8×11.5	202	8×11.5	221	10×12.5	294	10×16	332	10×20	375	12.5×25	506	16×25	645	18×35.5	837	
330	8×11.5	247	10×12.5	322	10×16	394	10×20	444	12.5×20	526	12.5×25	620	—	—	—	—	
470	10×12.5	350	10×16	420	10×20	513	12.5×20	607	12.5×25	685	16×25	861	—	—	—	—	
1000	10×20	611	12.5×20	767	12.5×25	935	16×25	1120	16×31.5	1270	—	—	—	—	—	—	
2200	12.5×25	1090	16×25	1380	16×31.5	1660	—	—	—	—	—	—	—	—	—	—	
3300	16×25	1490	16×31.5	1760	—	—	—	—	—	—	—	—	—	—	—	—	
4700	16×31.5	1880	18×35.5	2280	—	—	—	—	—	—	—	—	—	—	—	—	

(Note) Rated ripple current : 85°C, 120Hz

NOTE : Design, Specifications are subject to change without notice. It is recommended that you shall obtain technical specifications from ELNA to ensure that the component is suitable for your use.

ALUMINUM

MINIATURE ALUMINUM 85°C

FOR AUDIO ALUMINUM

## X-ON Electronics

Largest Supplier of Electrical and Electronic Components

*Click to view similar products for [Aluminium Electrolytic Capacitors - Radial Leaded](#) category:*

*Click to view products by [Taiyo Yuden](#) manufacturer:*

Other Similar products are found below :

[LXY50VB4.7M-5X11](#) [RFO-100V471MJ7P#](#) [ECE-A1EGE220](#) [1814181](#) [NCD681K10KVY5PF](#) [NEV1000M25EF-BULK](#) [NEV100M35DC](#)  
[NEV100M63DE](#) [NEV220M25DD-BULK](#) [NEV.33M100AA](#) [NEV4700M50HB](#) [NEV.47M100AA](#) [NEVH1.0M250AB](#) [NEVH3.3M250BB](#)  
[NEVH3.3M450CC](#) [KME50VB100M-8X11.5](#) [SG220M1CSA-0407](#) [ES5107M016AE1DA](#) [ESX472M16B](#) [476CKH100MSA](#) [477RZS050M](#)  
[UVX1V101KPA1FA](#) [UVX1V222MHA1CA](#) [KME25VB100M-6.3X11](#) [VTL100S10](#) [VTL470S10](#) [511D336M250EK5D](#) [052687X](#) [ECE-](#)  
[A1CF471](#) [EKXG451ELL820MM30S](#) [686CKR050M](#) [NRE-S560M16V6.3X7TBSTF](#) [ERZA630VHN182UP54N](#) [UPL1A331MPH](#)  
[NEV1000M6.3DE](#) [NEV100M16CB](#) [NEV100M50DD-BULK](#) [NEV2200M16FF](#) [NEV220M50EE](#) [NEV2.2M50AA](#) [NEV330M63EF](#)  
[NEV4700M35HI](#) [NEV4.7M100BA](#) [NEV47M16BA](#) [NEV47M50CB-BULK](#) [NEVH1.0M350AB](#) [NEVH2.2M160AB](#) [NEVH3.3M350BC](#)  
[TER330M50GM](#) [477KXM035MGBWSA](#)