

REV. Status  
 REVISION -  
 05/07/07 YS

LOW PROFILE, THREE FLANGE 6VA POWER TRANSFORMER APPROVED TO UL506 AND CSA C22.2 NO. 66-1988 AND USES A UL CLASS B (130°C) APPROVED INSULATION SYSTEM

MODEL NUMBER  
 3FL & PF 6VA

A. Electrical Specifications (@25°C)

1. Maximum Power: 6VA
2. Primary Voltage and Frequency: 115/230VAC  
50/60Hz.
3. Secondary RMS Rating: See Table A on sheet 2
4. voltage Regulation: 35% TYP @ full load to no load
5. Temperature Rise: 45°C TYP (60°C MAX)
6. Insulation Resistance:  
100MΩ MIN @ 500VDC, Pri to Sec, Pri to Core  
100MΩ MIN @ 500VDC, Sec to core
7. Dielectric Withstand:  
1500Vrms 1 minute @ Pri to Sec, Pri to Core  
1500Vrms 1 minute @ Sec to Core



B. Marking: TAMURA, Tamura part number (see sheet 2)  
 MICROTRAN, Microtran part number (see sheet 2)  
 date code, country of origin, safety logos  
 and input and output ratings (see sheet 2)

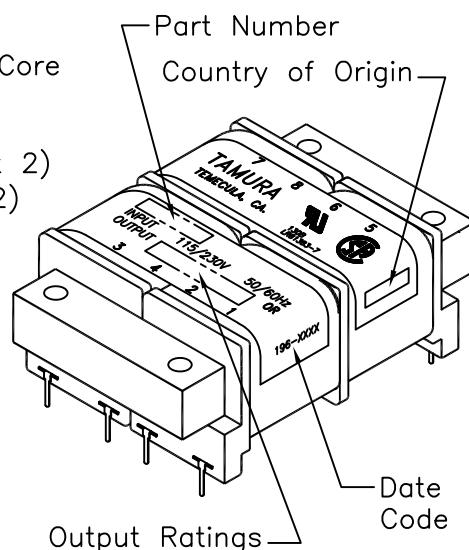

C. Safety:

UL approved, UL506 File E145619, E79781  
 Insulation Class B (130°C) File No E92957  
 CSA Certified, C22.2 No. 66 File 081383  
 (3FL Series)



D. Mechanical Specifications:

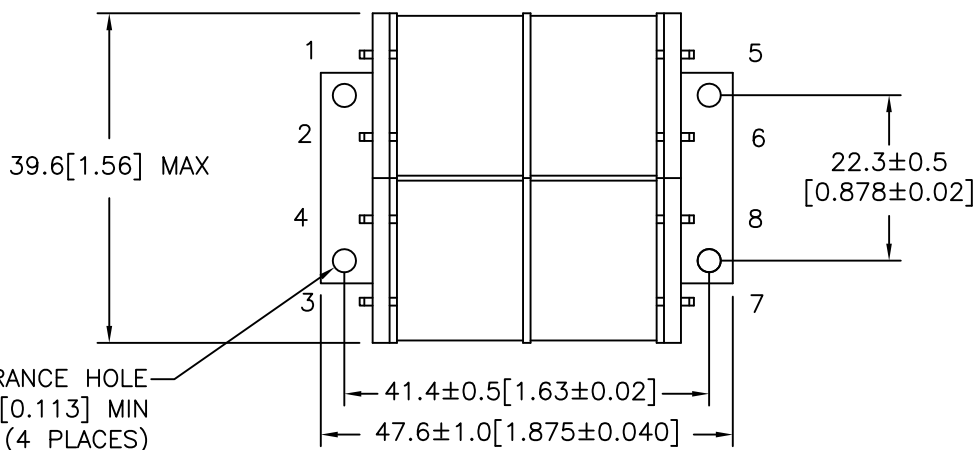
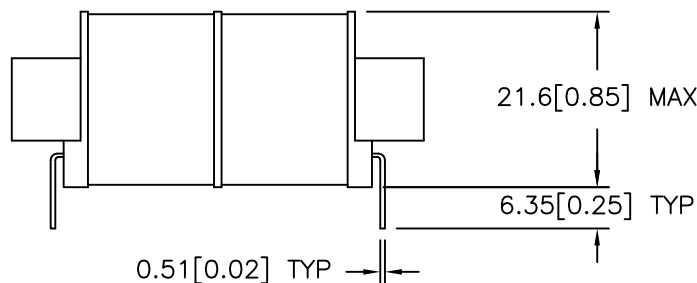
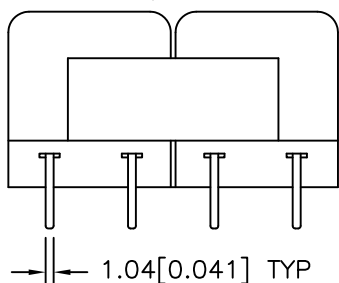

CLEARANCE HOLE  
 ø2.87 [0.113] MIN  
 (4 PLACES)

TOLERANCES (mm)
≤ 4 ± 0.2
4 ≤ 20 ± 0.3
20 ≤ 50 ± 0.4

PREPARED BY:  
 K. BRENNAN

ENGINEER:  
 M. PITCHAI  
 SAFETY ENGINEER  
 B. OCONNELL  
 APPROVED:  
 Y. SEKIGUCHI

DRAWING CONTROL NO.	REV	MODEL DESCRIPTION	MODEL SPECIFICATION
P-A1-11599	-	6VA 3FL & PF SERIES POWER TRANSFORMER	3FL & PF 6VA
CONTENTS OF THIS DRAWING ARE SUBJECT TO CHANGE WITHOUT PRIOR NOTICE		<b>TAMURA CORPORATION OF AMERICA</b> 1040 SOUTH ANDREASEN DRIVE, #100 ESCONDIDO, CA. 92029 (951) 699-1270 FAX 7607400536	DIM: mm [In] SCL: NONE SH: 1 OF 2
PROPRIETARY NOTICE: THIS DRAWING PRINT OR DOCUMENT AND SUBJECT MATTER DISCLOSED HEREIN ARE PROPRIETARY ITEMS TO WHICH TAMURA RETAINS THE EXCLUSIVE RIGHT OF DISSEMINATION, REPRODUCTION, MANUFACTURE AND SALE. THIS DRAWING, PRINT OR DOCUMENT IS SUBMITTED IN CONFIDENCE FOR CONSIDERATION BY THE RECIPIENT ALONE UNLESS PERMISSION FOR FURTHER DISCLOSURE IS EXPRESSLY GRANTED IN WRITING.			

E. Mounting Footprint:

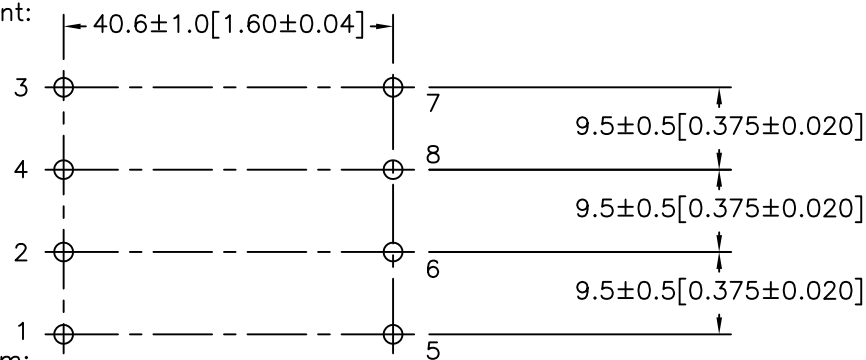

MODEL NUMBER  
**3FL & PF 6VA**

F. Schematic Diagram:

**PRIMARY INPUT CONNECTIONS**

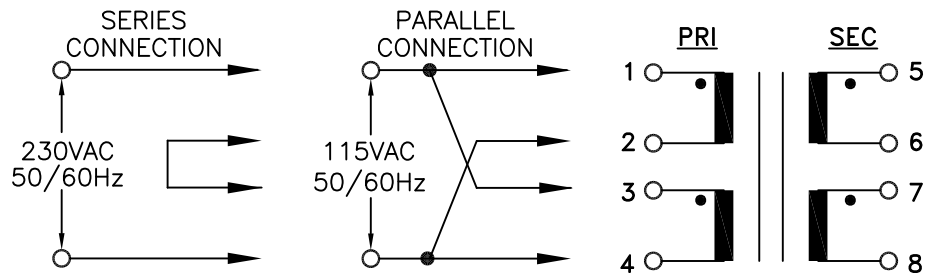

**SECONDARY OUTPUT CONNECTIONS**

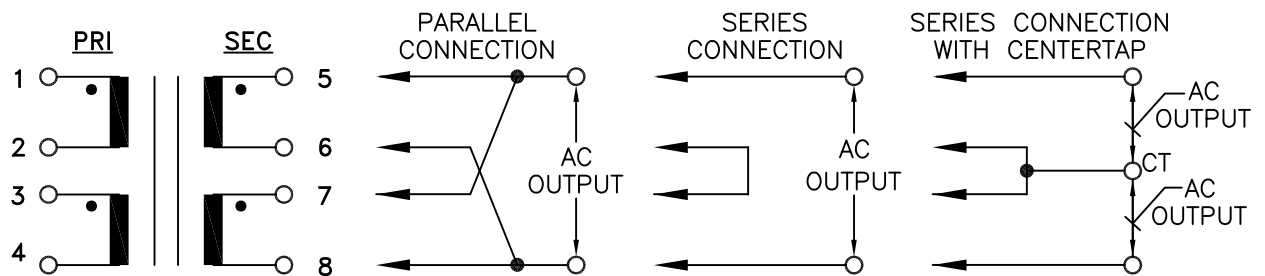

G. Table A:

TAMURA PART NO.	MICROTRAN PART NO.	PARALLEL CONNECTION		SERIES CONNECTION		SERIES CONNECTION WITH CT	
		AC VOLTS	RMS AMPS	AC VOLTS	RMS AMPS	AC VOLTS	RMS AMPS
3FL10-600	PF6-10	5.0	1.20	10.0	0.600	5.0-CT-5.0	0.600
3FL12-475	PF6-12	6.3	0.95	12.6	0.475	6.3-CT-6.3	0.475
3FL16-350	PF6-16	8.0	0.70	16.0	0.350	8.0-CT-8.0	0.350
3FL20-300	PF6-20	10.0	0.60	20.0	0.300	10.0-CT-10.0	0.300
3FL24-250	PF6-24	12.0	0.50	24.0	0.250	12.0-CT-12.0	0.250
3FL30-200	PF6-30	15.0	0.40	30.0	0.200	15.0-CT-15.0	0.200
3FL34-170	PF6-34	17.0	0.34	34.0	0.170	17.0-CT-17.0	0.170
3FL40-150	N/A	20.0	0.30	40.0	0.150	20.0-CT-20.0	0.150
3FL56-100	PF6-56	28.0	0.20	56.0	0.100	28.0-CT-28.0	0.100
3FL88-65	N/A	44.0	0.13	88.0	0.065	44.0-CT-44.0	0.065
3FL120-50	N/A	60.0	0.10	120.0	0.050	60.0-CT-60.0	0.050
3FL230-25	N/A	115.0	0.05	230.0	0.025	115.0-CT-115.0	0.025

PREPARED BY:

K. BRENNAN

ENGINEER:

M. PITCHAI

SAFETY ENGINEER

B. OCONNELL

APPROVED:

Y. SEKIGUCHI

DRAWING CONTROL NO.	REV
P-A1-11599	-

CONTENTS OF THIS DRAWING ARE SUBJECT TO CHANGE WITHOUT PRIOR NOTICE

**MODEL DESCRIPTION**  
6VA 3FL & PF SERIES  
POWER TRANSFORMER  
**TAMURA CORPORATION OF AMERICA**  
1040 SOUTH ANDREASEN DRIVE, #100 ESCONDIDO, CA. 92029  
(951) 699-1270 FAX 7607400536

**MODEL SPECIFICATION**  
**3FL & PF 6VA**

DIM: mm[In] SCL: NONE SH: 2 OF 2

PROPRIETARY NOTICE: THIS DRAWING PRINT OR DOCUMENT AND SUBJECT MATTER DISCLOSED HEREIN ARE PROPRIETARY ITEMS TO WHICH TAMURA RETAINS THE EXCLUSIVE RIGHT OF DISSEMINATION, REPRODUCTION, MANUFACTURE AND SALE. THIS DRAWING, PRINT OR DOCUMENT IS SUBMITTED IN CONFIDENCE FOR CONSIDERATION BY THE RECIPIENT ALONE UNLESS PERMISSION FOR FURTHER DISCLOSURE IS EXPRESSLY GRANTED IN WRITING.

## **X-ON Electronics**

Largest Supplier of Electrical and Electronic Components

*Click to view similar products for [Power Transformers](#) category:*

*Click to view products by [Tamura](#) manufacturer:*

Other Similar products are found below :

[ET-030A](#) [F-102X](#) [F-120X](#) [F-14X-1](#) [F-181U](#) [F-18A](#) [F-199U](#) [F-19X](#) [F-202U](#) [F-204U](#) [F-206U](#) [F-227X](#) [F-238U](#) [F-239U-1](#) [F-23U](#) [F24-250-B](#)  
[F-242U](#) [F-245U](#) [F-264U](#) [F-265U](#) [F-267U](#) [F-281U](#) [F-283U](#) [F-290X](#) [F-295Z](#) [F-296Z](#) [F-298Z](#) [F-3143P](#) [F-3298Z](#) [F-33U](#) [F-346X](#) [F-35U](#) [F-](#)  
[364U](#) [F-392A](#) [F-395X](#) [F-397U](#) [F-412X](#) [F-47U](#) [F-55X-1](#) [F-60U](#) [F-68U](#) [F-71U](#) [F-72Z](#) [F-74U](#) [F-83A](#) [F-84AC](#) [F-85U](#) [F-86U](#) [F-9U](#) [PCT-02](#)