

REV. Status

ISSUE 2
REVISED AND
REDRAWN ON
CAD/CAM
01/08/92 HA

ISSUE 3
TEMECULA
WAS CARSON
01/26/93 TS

ISSUE 4
ADDED DCM21-PC
MICROTRAN
AND SAFETY
01/20/96 TS

TELECOMMUNICATION DRY COUPLING TRANSFORMER DESIGNED TO OPERATE AT A MAX LEVEL OF +7dBm AND TO REFLECT A PRIMARY SOURCE IMPEDANCE OF APPROXIMATELY 600ΩCT WITH 600ΩCT LOAD ON SECONDARY



MODEL NUMBER
TTC-108

- A. Electrical Specifications (@ 25 ° C)
- Pri Source Impedance; 600Ω CT
 - Sec Load Impedance; 600Ω CT
 - Operating Level; -45 dBm to +7 dBm
 - Insertion Loss; 1.4 dB MAX @ 1 KHz, 0 dBm
 - Frequency Response; ±0.5 dB 300 Hz to 3.5 KHz @ 0 dBm
 - Primary Impedance; 600 Ω +15%, -5% @ 300 Hz to 3.5 KHz, 0dBm
600 Ω +10%, -5% @ 500 Hz to 2.5 KHz, 0dBm
 - Longitudinal Balance; 60 dB MIN @ 200 Hz to 1 KHz
40 dBm MIN @ 4 KHz
 - DC Resistance; (1-3) = 44 Ω ±20%
(4-6) = 56 Ω ±20%
 - Turns Ratio; (1-3) : (4-6) = 1 : 1.00 ±2%
 - Dielectric Strength; 1500 Vrms 1 minute @ Pri to Sec, and Pri to Core
1000 Vrms 1 minute @ Sec to Core
 - Total Harmonic Distortion; 0.5% MAX @ 300 Hz to 3.5 KHz, 0 dBm
 - Induced Voltage; (1-3) 250 Vrms 5 KHz 1 minute

B. Marking; TTC-108, TAMURA, DCM21-PC, MICROTRAN, safety agency logos, 196-date code and country of origin

C. Safety; CSA-22.2 No. 66-M1988 File No. LR81383
UL 1863 File No. E142035

D. Schematic Diagram

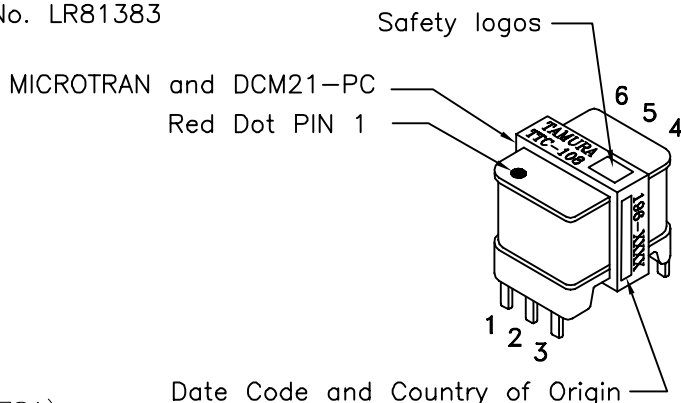
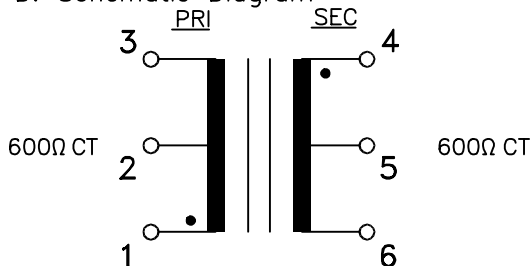

E. Mechanical Specifications

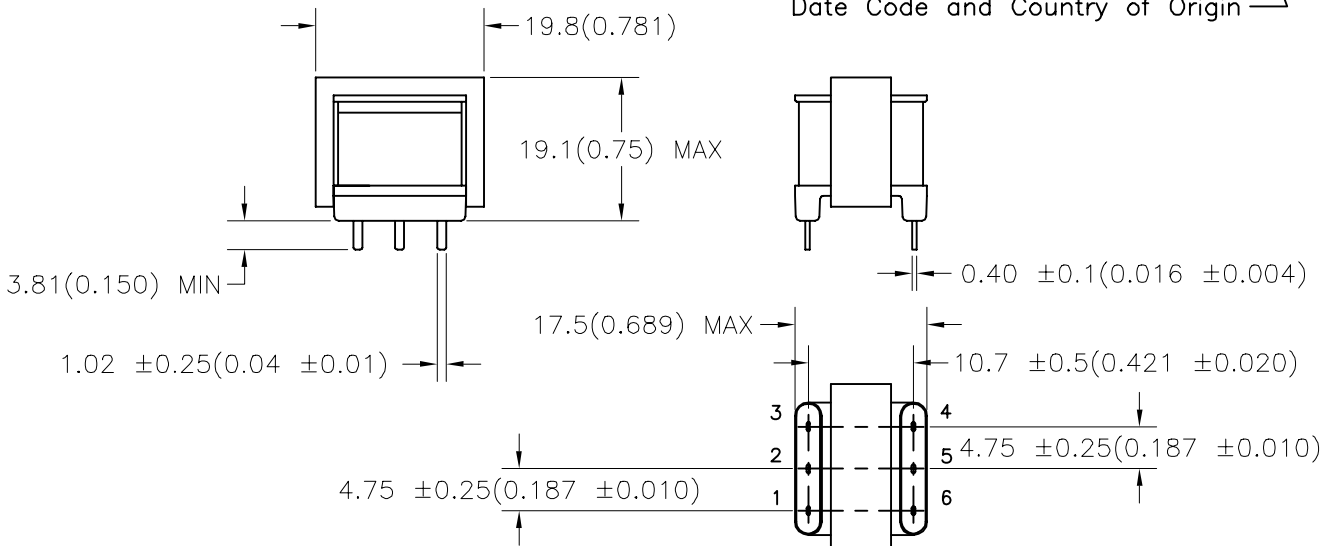

TOLERANCES (mm)
≤ 4 ± 0.2
4 ≤ 20 ± 0.3
20 ≤ 50 ± 0.4

PREPARED BY:

K. Brennan

ENGINEER:

T. Shiozawa

QUALITY CONTROL:

V. Casey

APPROVED:

V. Casey

DWG CONTROL NO. P-A1-10017
ACAD\TTC\A1100171.DWG

REV C

TELECOMMUNICATION COUPLING TRANSFORMER

TAMURA CORPORATION OF AMERICA
43352 BUSINESS PARK DRIVE, TEMECULA, CA. 92590-6624
(909) 699-1270 FAX 9096769482

TTC-108
MODEL SPECIFICATION
DIM: mm(In) SCL: 1/1 SH: 1 OF 1

PROPRIETARY NOTICE: THIS DRAWING PRINT OR DOCUMENT AND SUBJECT MATTER DISCLOSED HEREIN ARE PROPRIETARY ITEMS TO WHICH TAMURA RETAINS THE EXCLUSIVE RIGHT OF DISSEMINATION, REPRODUCTION, MANUFACTURE AND SALE. THIS DRAWING, PRINT OR DOCUMENT IS SUBMITTED IN CONFIDENCE FOR CONSIDERATION BY THE RECIPIENT ALONE UNLESS PERMISSION FOR FURTHER DISCLOSURE IS EXPRESSLY GRANTED IN WRITING.

X-ON Electronics

Largest Supplier of Electrical and Electronic Components

Click to view similar products for [Audio Transformers](#) / [Signal Transformers](#) category:

Click to view products by [Tamura](#) manufacturer:

Other Similar products are found below :

[CX2041NLT](#) [MGPWT-00449-P](#) [PE-64961](#) [H1302FNLT](#) [H5008FNL](#) [H5012FNL](#) [H5020FNLT](#) [H5077NLT](#) [H5079NLT](#) [H5084FNLT](#)
[B78476A9558A003](#) [1812WBT2-4](#) [1879479-1](#) [HX2260FNL](#) [HX5014FNL](#) [EX2024FNL](#) [FL1066](#) [T1137NLT](#) [T3012NL](#) [PE-65812FNL](#) [PE-65848FNLT](#) [H1174FNL](#) [H1302FNL](#) [H5015FNL](#) [H5019EFNL](#) [H5062FNLT](#) [CX2047LNL](#) [MGPWT-00059-P](#) [MGPWT-00266-P](#) [MGPWT-00278-P](#) [MGPWT-00431-P](#) [TTC-100](#) [TTC-143-H](#) [TTC-5032-1](#) [BX1194WNLT](#) [HX1234NLT](#) [HX5008FNLT](#) [HX5019FNL](#) [HX5084NL](#) [3-1879385-5](#) [TX1263NLT](#) [4-1879391-0](#) [T1142NL](#) [HX6101FNL](#) [HX5084FNL](#) [HX1148NL](#) [HX5020FNLT](#) [HX5014FNLT](#) [T1124NL](#)
[1879732-1](#)