



**TAOGLAS**®



## Taoglas mmWave Adaptors and Connectors Catalogue

Next-Generation Adaptors and  
Connectors for **5G NR** applications

## Contents

1. Introduction	3
2. 2.92mm Adaptors & Connectors	4
3. Specifications	7
4. Test Setup	8

Taoglas makes no warranties based on the accuracy or completeness of the contents of this document and reserves the right to make changes to specifications and product descriptions at any time without notice. Taoglas reserves all rights to this document and the information contained herein. Reproduction, use or disclosure to third parties without express permission is strictly prohibited.

## mmWave Adaptors and Connectors

**As 5G development continues, the diversity of applications such as high-speed communications, satellite communications, military and aerospace, alongside the ever-changing demands for higher-frequency test systems are driving coaxial cable assemblies and connectors to the next level.**

To allow for complete compatibility with end use-cases, the Taoglas series of connectors and adaptors, which are all cross-mateable to other industry standard connectors. The adaptors allow you to interface 2.92mm connectors with , including SMA(F), SMP(F), 2.4(F) and 2.92(F) connectors and are available in female to female, female to male combinations. The connectors and adaptors support DC of up to 40GHz frequencies, are rated to 50 Ohm impedance, while exhibiting low VSWR and low RF leakage. The connectors are precision engineered from high-quality materials and undergo stringent reliability testing to provide superior reliability for the most demanding of applications.

The 2.92mm connector was developed for compatibility up to 40 GHz. The male pin is shorter than that in a standard SMA connector and ensures that the outer contacts of the male and female connectors engage before the pin and female receptacle engage. This ensures that the pin and socket will not see excessive wear and mating stress seen by misalignment in SMA connectors for example and ensures consistent performance. The 2.92mm connector also has a thicker wall than a standard SMA connector. The 2.92mm adaptors category also includes 2 or 4 hole panel mount, PCB vertical mount and PCB edge mount configurations..

### Typical Use Cases:

- 5G mmWave Networks and Communications Infrastructure
- High-frequency, small cell-based wireless access points
- MIMO ultra-high speed outdoor backhaul fixed and moving wireless access points
- Test and measurement instrumentation
- High-speed, Mil-Aero, SATCOM, and instrumentation applications

### Features and Benefits:

- High-frequency bands coverage (DC to 40 GHz)
- Low Isolation
- 2.92mm cross-mateable to other industry standards
- RoHS & Reach Compliant

For configurations not listed here, we can provide solutions based on your requirements pending an MOQ, please contact your local customer services department to discuss further.

## 2. 2.92mm Adaptors & Connectors

### 2.92mm Adaptors

#### 2.92(F) to SMA(F) mmWave Adaptor

Part Number

292FST.SMAF.N.XS	VSWR	Return Loss	Insertion Loss	Frequency	Impedance
	≤1.15	> -19.085dB	0.32dB	27GHz	50Ω

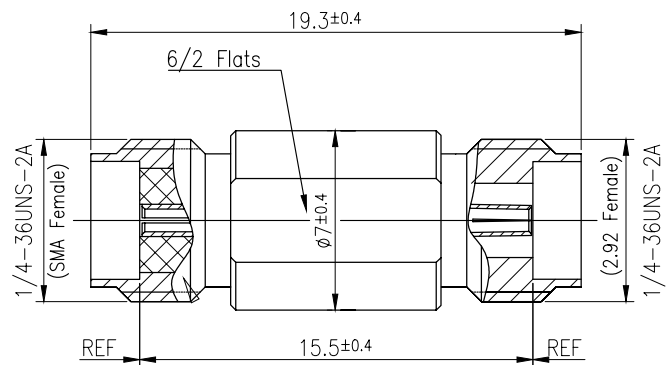

#### 2.92(F) to SMP(F) mmWave Adaptor

Part Number

292FST.SMPF.N.XS	VSWR	Return Loss	Insertion Loss	Frequency	Impedance
	≤1.25	> -17.692dB	0.32dB	40GHz	50Ω

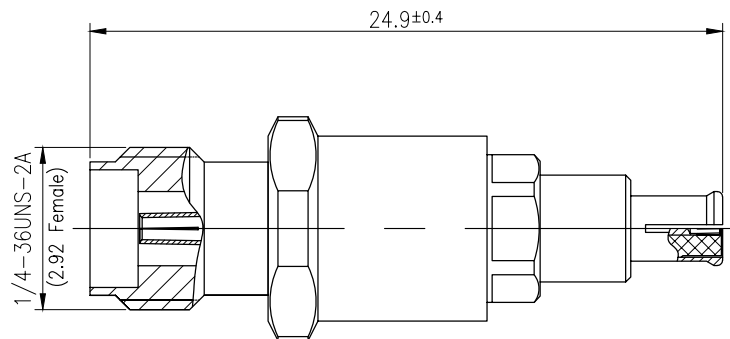
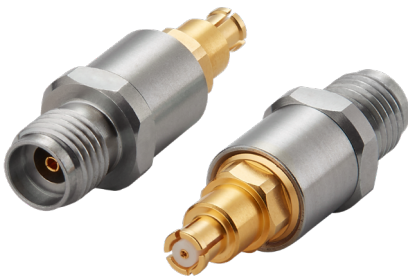

#### 2.92(F) to 2.4(F) mmWave Adaptor

Part Number

292FST.24F.N.XS	VSWR	Return Loss	Insertion Loss	Frequency	Impedance
	≤1.20	> -20.828dB	0.32dB	40GHz	50Ω

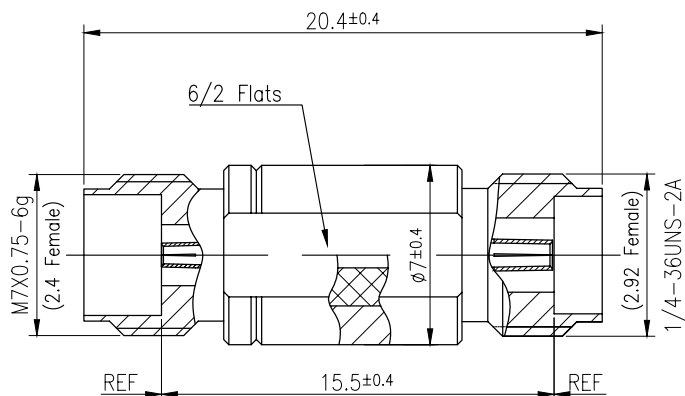

## 2.92(F) to 2.4(M) mmWave Adaptor

Part Number

292FST.24M.N.XS	VSWR	Return Loss	Insertion Loss	Frequency	Impedance
	≤ 1.20	> -19.085dB	0.32dB	40GHz	50Ω

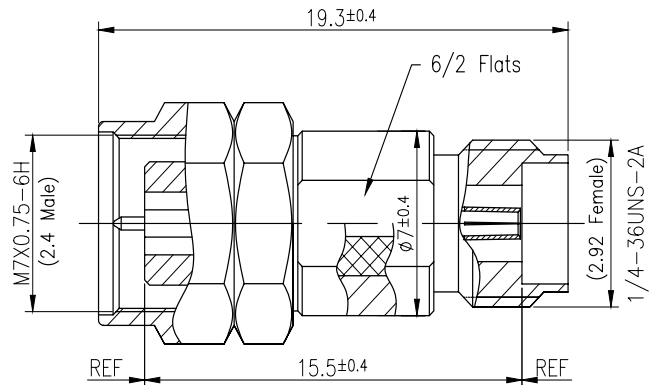

## 2.92(F) to 2.92(F) mmWave Adaptor

Part Number

292FST.292F.N.XS	VSWR	Return Loss	Insertion Loss	Frequency	Impedance
	≤ 1.20	> -19.085dB	0.32dB	40GHz	50Ω

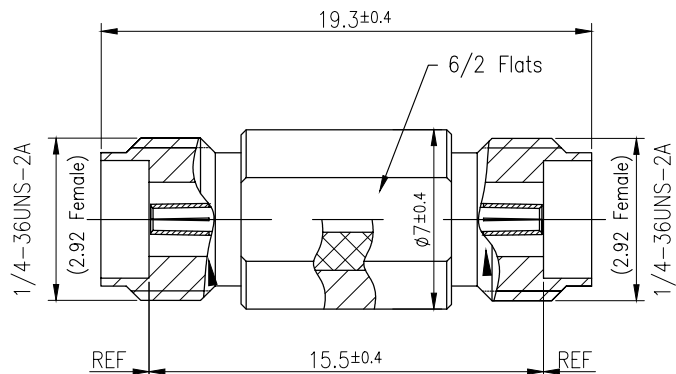

## 2.92mm on board Connectors

### 2.92(F) PCB Mount 2 Hole Vertical Straight on board Connector

Part Number

PCB.292FST.2H.XS	VSWR	Return Loss	Insertion Loss	Frequency	Impedance
	≤ 1.20	> -17.692dB	0.38dB	40GHz	50Ω

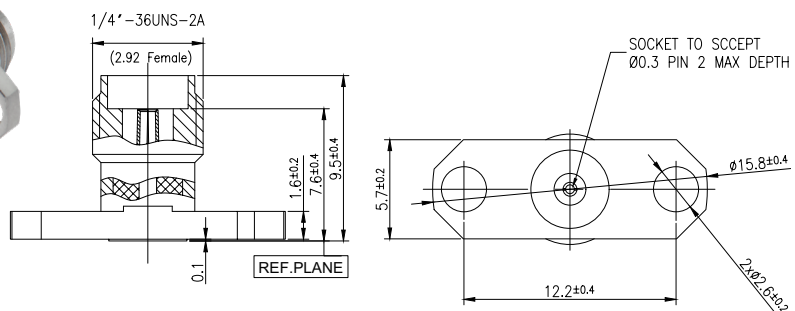

## 2.92(F) PCB Mount 4 Hole Vertical Straight on board Connector

Part Number

PCB.292FST.4H.XS	VSWR	Return Loss	Insertion Loss	Frequency	Impedance
	≤1.20	> -20.828dB	0.38dB	40GHz	50Ω

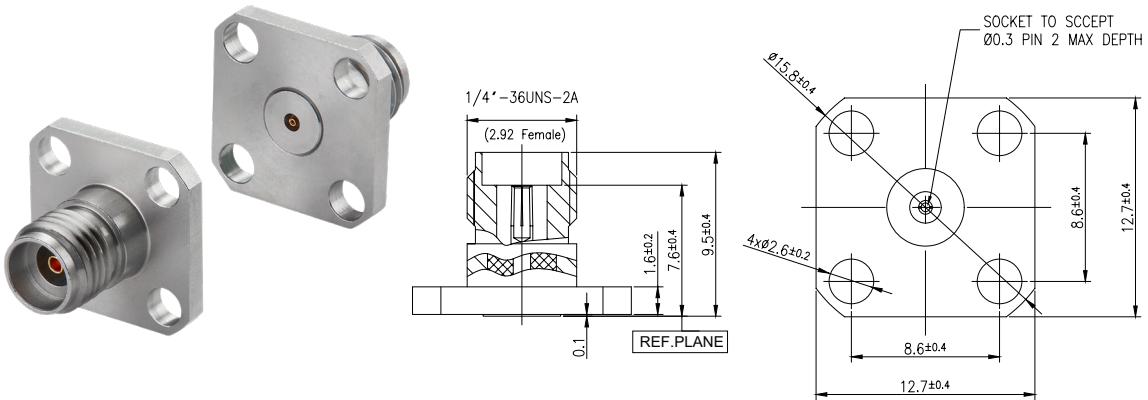

## 2.92(F) PCB Vertical on board Connector

Part Number

VMPCB.292FST.A.XS	VSWR	Return Loss	Insertion Loss	Frequency	Impedance
	≤1.20	> -17.692dB	0.38dB	40GHz	50Ω

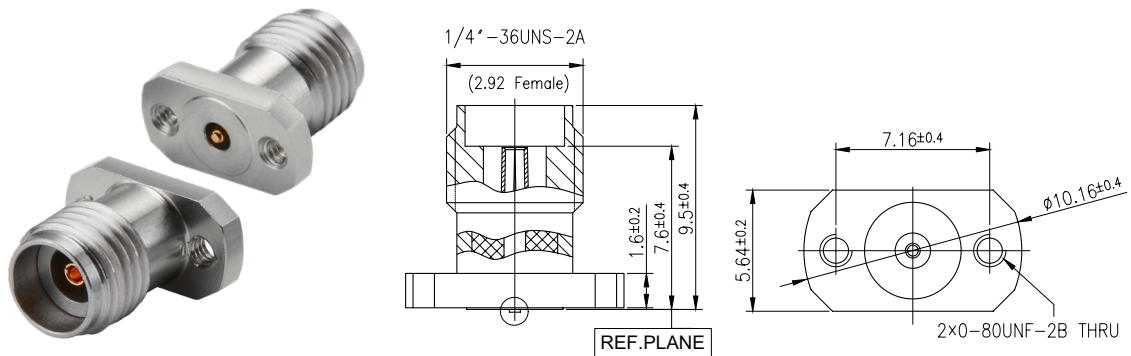

## 2.92(F) Edge Mount PCB on board Connector

Part Number

EMPCB.292FST.A.XS	VSWR	Return Loss	Insertion Loss	Frequency	Impedance
	≤1.25	> -15.563dB	0.35dB	40GHz	50Ω

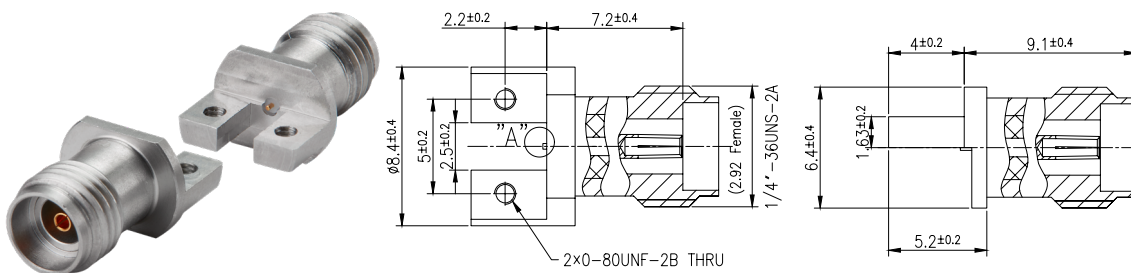

# 3. Specifications

Specifications	
Electrical	
Contact resistance	<p><b>Center:</b> Not greater than 6m<math>\Omega</math></p> <p><b>External:</b> Not greater than 2m<math>\Omega</math></p>
Insulation resistance	1,000M $\Omega$ min.
Withstanding voltage	<p>No flashover or breakdown</p> <p><b>0.32dB for:</b> 2.92(F) to 2.4(F) mmWave Adaptor</p>
Mating Cycles	<p><b>Contact resistance:</b> 500 cycles</p> <p><b>Center:</b> Not greater than 8m<math>\Omega</math></p> <p><b>External:</b> Not greater than 4m<math>\Omega</math>. No broken, cracked, or loose parts</p>
Mechanical	
Vibration resistance	<p><b>MIL-STD-202, Method 204, Condition D, 20 Gs</b> No electrical discontinuity for not less than 1<math>\mu</math>s. No broken, cracked, or loose parts</p>
Shock resistance	<p><b>MIL-STD-202, Method 213, Condition I, 100 Gs</b> No electrical discontinuity for not less than 1<math>\mu</math>s. No broken, cracked, or loose parts</p>
Moisture resistance of temperature/humidity cycle	<p><b>MIL-STD-202, Method 106, Less Step 7B</b> <b>High Humidity Environment Insulation Resistance:</b> Not less than 100M<math>\Omega</math> <b>Dry Environment Insulation Resistance:</b> Not less than 1,000M<math>\Omega</math>. No broken, cracked or loose parts</p>
Salt spray	<p><b>MIL-STD-202, Method 101, Condition B</b> No considerable corrosion</p>
Temperature cycle	No broken, cracked or loose parts
Storage Temperature	-55c to +50c (95% RH or less)
Operating Temperature	-55c to +50c (95% RH or less)
PCB Mount Connector Material Specifications	<p><b>Body</b> Brass per ASTM B16, Alloy UNS No. C36000</p>
	<p><b>Insert:</b> Stainless Steel per AMS-5640, Alloy UNS S30300, Type 1</p>
	<p><b>Contact:</b> Beryllium Copper per ASTM B196, Alloy No. UNS C17300, TD04</p>
	<p><b>Dielectric Bead:</b> Ultem 1000</p>
Adaptor Material Specifications	<p><b>Finish: Body, Insert &amp; Contact</b> Gold per ASTM B 488, Type II, Code C, Class 0.76, over Nickel per AMS-QQ-N-290, Class 1, .00010" min.</p>
	<p><b>Bodies, Inserts &amp; Coupling Nut:</b> Stainless Steel per AMS-5640, Alloy UNS S30300, Type 1 Lock Ring &amp;</p>
	<p><b>Contacts:</b> Beryllium Copper per ASTM B196, Alloy NO. UNS C17300, TD04</p>
	<p><b>Sleeve:</b> Brass per ASTM B16, Alloy UNS No. C36000</p>
	<p><b>Beads:</b> Polyetherimide per ASTM D5205 "Ultem 1000"</p>
	<p><b>Bellows Springs:</b> Electro-deposited Gold over Nickel</p>
	<p><b>Gasket:</b> Silicone Rubber per A-A-59588, Class 2B, Grade 50/60</p>
	<p><b>Resistor Element:</b> Aluminium Nitride Substrate with Tantalum Nitride Resistor: Gold plated terminations</p>
	<p><b>Detent:</b> Smooth bore, limited detent, full detent</p>

## 4. Test Setup

Test Condition	Test Exposure and Duration
<b>Low Temperature test</b>	Expose the specimen to -40°C for 400 hours and then to normal temperature/humidity for 24 hours or more. After this test, examine its appearance and functions.
<b>High-temperature test</b>	Expose the specimen to + 105°C for 400 hours and then to normal temperature/humidity for 24 hours or more. After this test, examine its appearance and functions.
<b>High-temperature/ high-humidity test</b>	Subject the object to the environmental conditions of +60°C and 90-95% relative humidity for 96 hours, then expose it to normal temperature/humidity for 24 hours or more. After this test, examine its appearance and functions.
<b>Thermal shock test</b>	Subject the object to cyclic temperature change (-40°C for 2 hours, then +85°C for 2 hours) for 100 cycles, then expose to normal temperature/ humidity for 24 hours or more.
<b>Sinusoidal vibration test</b>	Subject the object to vibrations of 5 to 200 to 5Hz swept in to minutes, 4.5G at maximum (2 mm amplitude), in X and Y directions for two hours each and in Z direction for four hours. After this test, examine its appearance functions.
<b>Vibration test in packaged condition</b>	Subject the object, which is packaged as illustrated, to vibrations of 15 to 60 to 15Hz swept in 6 minutes, 4G at maximum (2mm amplitude at maximum), applied in X, Y and Z directions for two hours each, i.e. six hours in total. After this test, examine its appearance and functions.
<b>Free fall test in packaged condition</b>	Drop the object, which is packaged as illustrated, to a concrete surface from the height of 90cm, on one corner, three edges and six faces once each, i.e. 10 times in total. After this test, examine its appearance and functions.
<b>Soldering heat resistance test</b>	After the lead pins of the unit are soaked in solder bath at 260 ± 5°C for 10 seconds. After this test, examine its appearance and functions.
<b>Adhesion test</b>	The device is subjected to be soldered on test PCB. Then apply 0.5 Kg (5N) of force for 5±1 second in the direction of parallel to the substrate (the soldering should be done by reflow and be conducted with care so that the soldering is uniform and free of defect by stress such as heat shock).

## Cable Builder and Antenna Builder

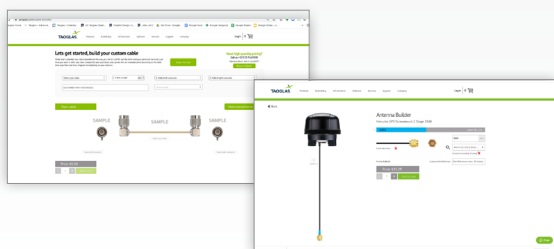

### Jumpstart Your Prototypes

Let us help you with your wireless and IoT designs with quick and easy access to precisely the cables and antennas you need. **Shipped to you within 2 days!**

#### One easy process

Simply select and specify your components and purchase online. Your custom products will be assembled in one of Taoglas' global facilities and shipped immediately to you.

[www.taoglas.com/antenna-builder](http://www.taoglas.com/antenna-builder)

[www.taoglas.com/cable-builder](http://www.taoglas.com/cable-builder)

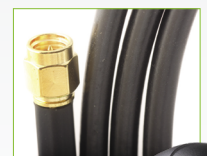





**TAOGLAS®**

[taoglas.com](https://taoglas.com)

## X-ON Electronics

Largest Supplier of Electrical and Electronic Components

*Click to view similar products for [RF Adapters - In Series](#) category:*

*Click to view products by [Taoglas](#) manufacturer:*

Other Similar products are found below :

[5916-1103-603](#) [5919-1503-000](#) [5919-9503-000](#) [651A505](#) [82-5552](#) [9030-9523-502](#) [PN2C](#) [A0407000](#) [R114703000W](#) [R125771001](#)  
[R127871001](#) [R141710000W](#) [R141723161](#) [R141730000](#) [R143730700](#) [R143770000](#) [R161703000W](#) [R161753000W](#) [R161791530W](#)  
[R201705000](#) [R222705200](#) [R222M40010W](#) [R222M40050](#) [R223703180](#) [R316754000](#) [R405006000](#) [R443162000](#) [AD78TL](#) [HRM-513S](#)  
[1996352-2](#) [2157155-1](#) [252169-75](#) [AD158](#) [2101130-1](#) [252186](#) [R114704000W](#) [R114720000W](#) [R125705001](#) [R125705701](#) [R125771000](#)  
[R125771001W](#) [R127704001](#) [R127.870.001](#) [R127872001](#) [R142710000](#) [R142723000](#) [R143703000](#) [R143704000](#) [R143705700](#) [R143710000](#)