

SPECIFICATION

- Part No. : **AGGBP.25A.07.0060A**
- Description : 25x25mm One Stage GPS-GLONASS-GALILEO-BeiDou Embedded Active Patch Antenna Module with Front-End SAW Filter
- Features : Full GPS-GLONASS-GALILEO-BeiDou Coverage
18dB One-stage LNA
Ceramic patch element
Front-end SAW filter to reduce out of band noise
Wide input voltage 1.8V to 5.5V
25.1 x 25.1 x 7.9mm
60mm Ø1.13 IPEX MHFI (U.FL)
Automotive TS16949 Production and Quality Approved
Cable length and connector type customizable
RoHS compliant



1. Introduction

The AGGBP.25A is an internal GPS/GLONASS/GALILEO/BeiDou active patch antenna with Ø1.13 cable and IPEX MHFI (U.FL compatible) connector. It is the ideal antenna for next generation GNSS devices to achieve good sensitivity across all bands in a small form factor.

The active patch antenna, by means of a double resonance design, has a wide-band operation over GPS/GLONASS/GALILEO/BeiDou systems from 1561MHz to 1606MHz. It includes a one-stage LNA and front-end SAW filter to reduce out of band noise, such as from nearby cellular transceivers. This antenna offers better protection from nearby radiated power surges and greatly reduces the probability of damaging your GPS/GLONASS/GALILEO/BeiDou receiver due to nearby transmissions.

The patch, the ground plane, the LNA, and front-end SAW components are all integrated in a dimension of 25.1 x 25.1 x 7.9 mm, connecting with a Ø1.13 60mm long coaxial cable and an IPEX MHFI connector. The AGGBP.25A is manufactured and tested in a TS16949 first tier automotive approved facility. The cable length and connector type can be adjusted for a MOQ.

For further optimization to customer specific device environments, custom tuned patch antennas can be supplied, again to a MOQ. For more details please contact your regional Taoglas sales office.

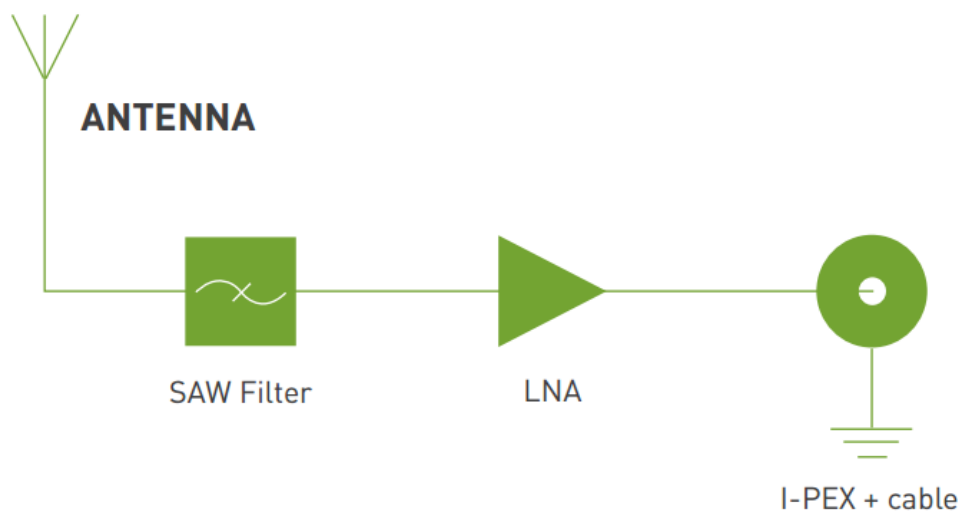

2. Specification

2.1. Patch Antenna

ELECTRICAL	
Frequency	GPS: 1575.42 ± 1.023MHz Galileo: 1575.42 ± 4GHz GLONASS: 1602 ± 5MHz BeiDou: 1561.098 ± 2.046MHz.
Polarization	RHCP
Antenna Gain at Zenith (Ceramic Patch only)	GPS/Galileo 1575.42MHz: -2.5 dBi typ. @zenith GLONASS 1602MHz: -1.5 dBi typ. @zenith BeiDou 1561MHz: -1 dBi typ. @zenith
Total Antenna Gain at Zenith (Antenna+SAW+LNA+ Cable+Connector)	GPS/Galileo 1575.42MHz: 15.5 ± 3dBi GLONASS 1602MHz: 16.5 ± 3dBi BeiDou 1561MHz: 17 ± 3dBi
Impedance	50 ohms
Output VSWR	Max 2.0
MECHANICAL	
Ceramic Dimension	25.1 x 25.1 x 4.7mm
Total Dimension (including shielding case)	25.1 x 25.1 x 7.9mm
Connector	IPEX MHFI (U.FL)
Cable	coaxial cable Ø1.13, length 60mm
Weight (g)	11.38
ENVIRONMENTAL	
Operation Temperature	-40°C to 85°C
Storage Temperature	-40°C to + 85°C
Humidity	Non-condensing 65°C 95% RH

2.2. LNA

ELECTRICAL			
Frequency	1558~1610 MHz.		
Out of Band Attenuation	0-1534MHz, 13dB Min. 1634MHz-6000MHz, 20dB Min.		
Output Impedance	50Ω		
Output VSWR	2.0 Max		
Pout at 1dB Gain	-6 dBm Min.		
Compression Point	-2 dBm Typical		
LNA Gain, Power Consumption and Noise Figure			
Voltage	LNA Gain(Typ)	Power Consumption(mA) Typ	Noise Figure (Typ)
Min 1.8V	12dB	5mA	3.0dB
Typ 3.0V	18dB	10mA	2.8dB
Max 5.5V	22dB	23mA	3.0dB

3. LNA Gain and Noise Figure @3.0V

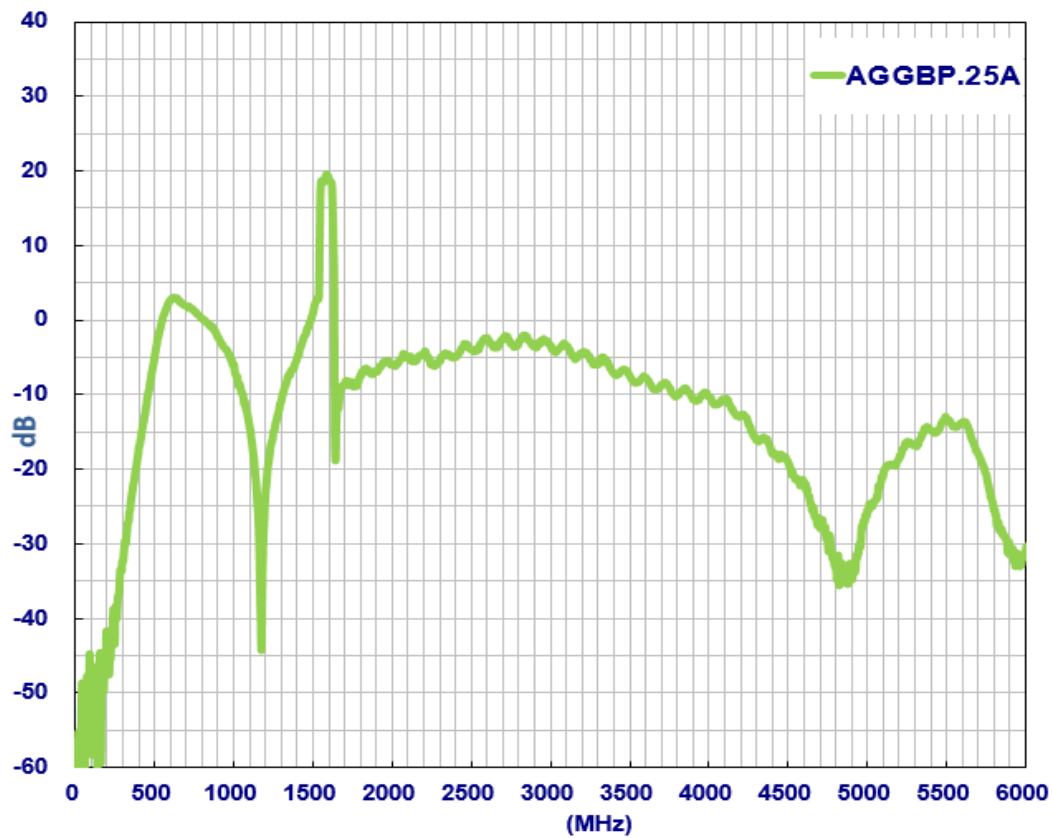
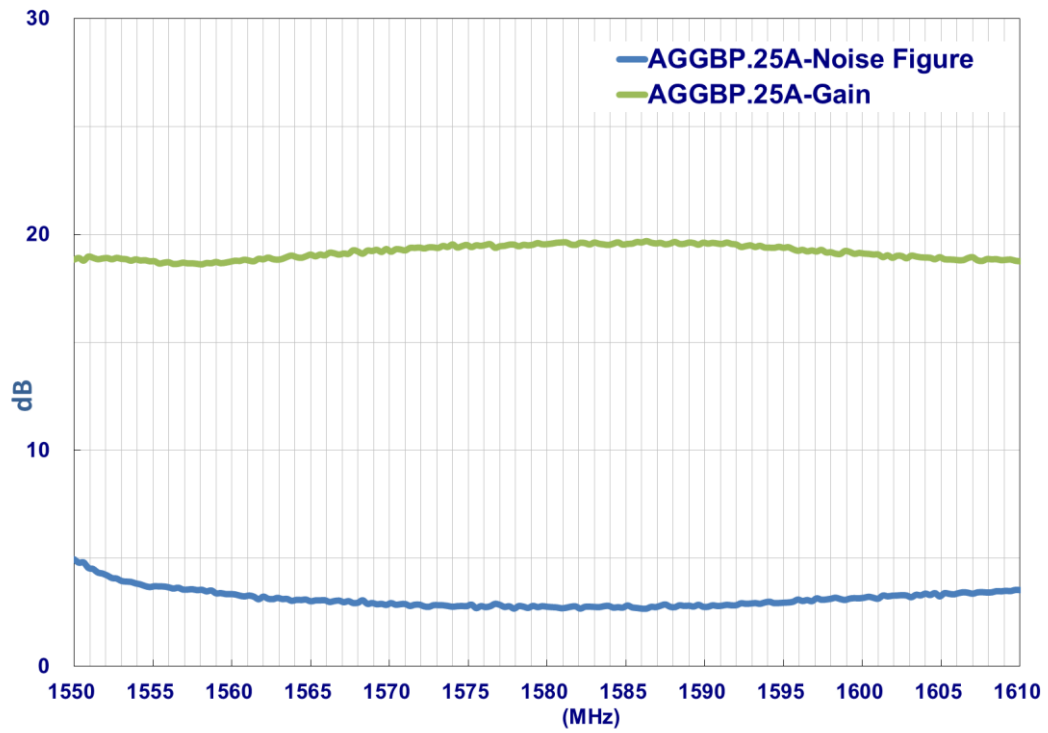

4. Antenna Return Loss

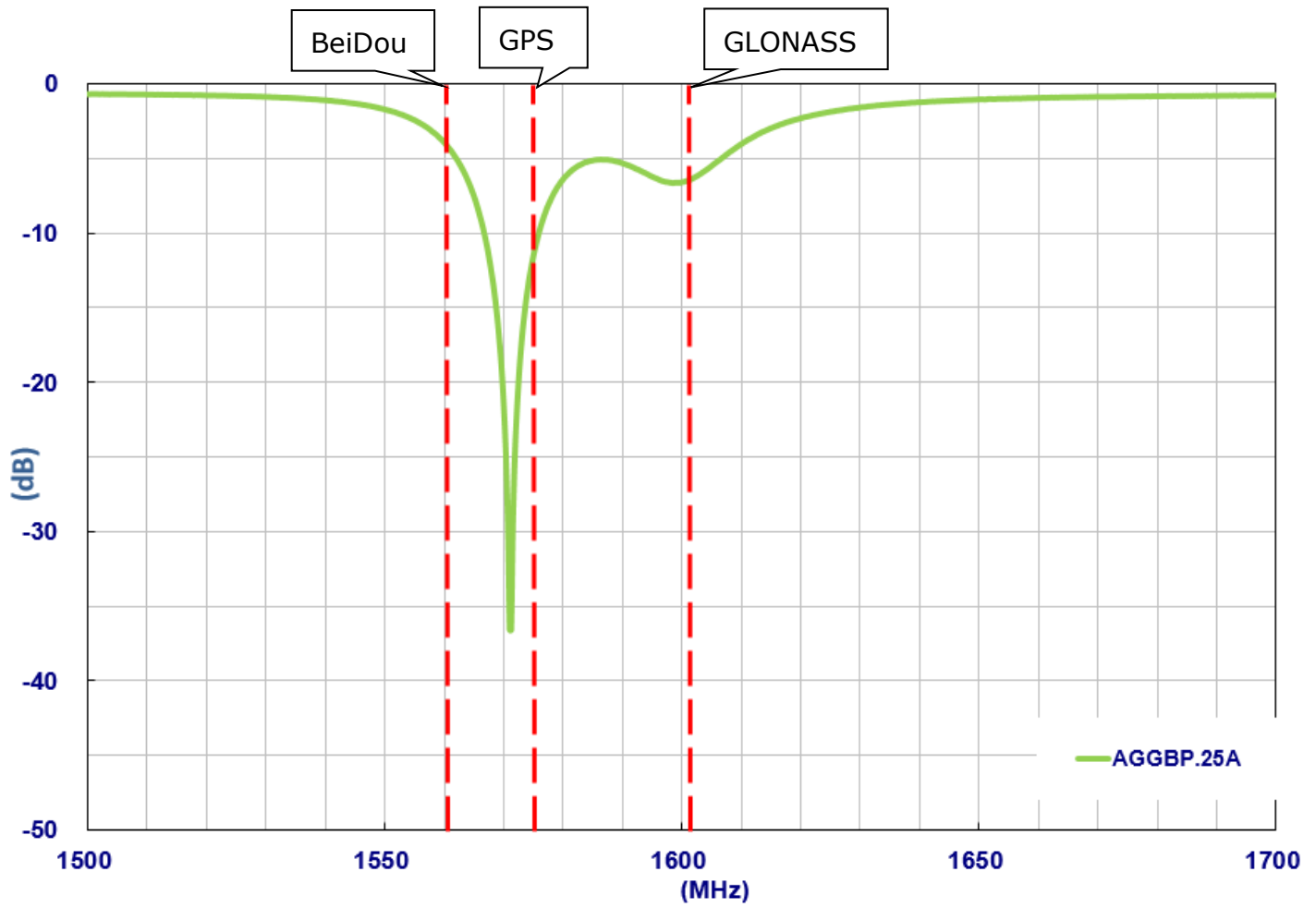

5. Antenna Radiation Properties

5.1. Test Setup

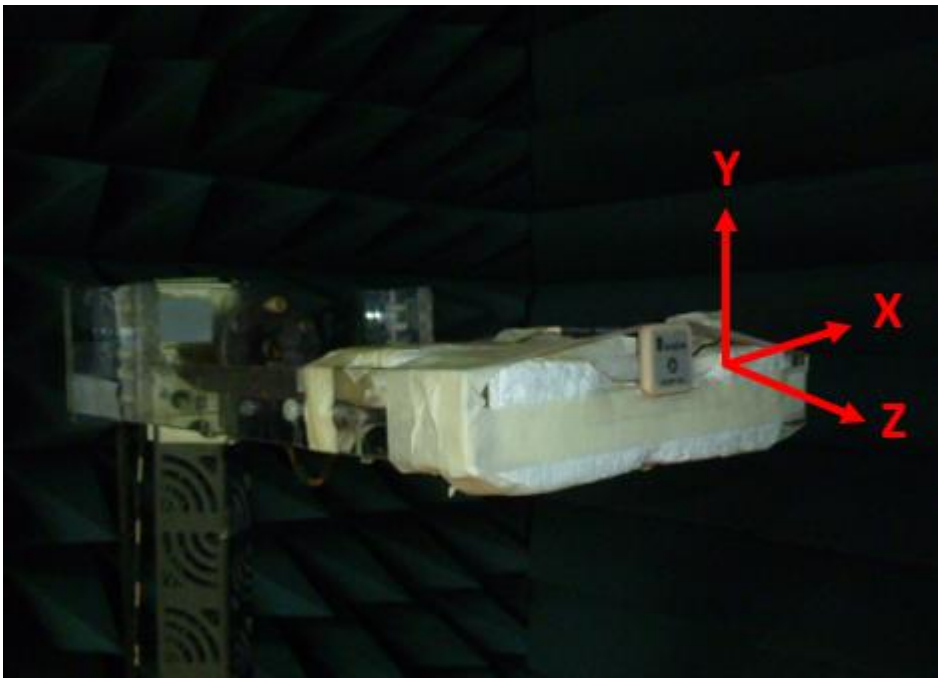

5.2. 2D Radiation Pattern

XY Plane

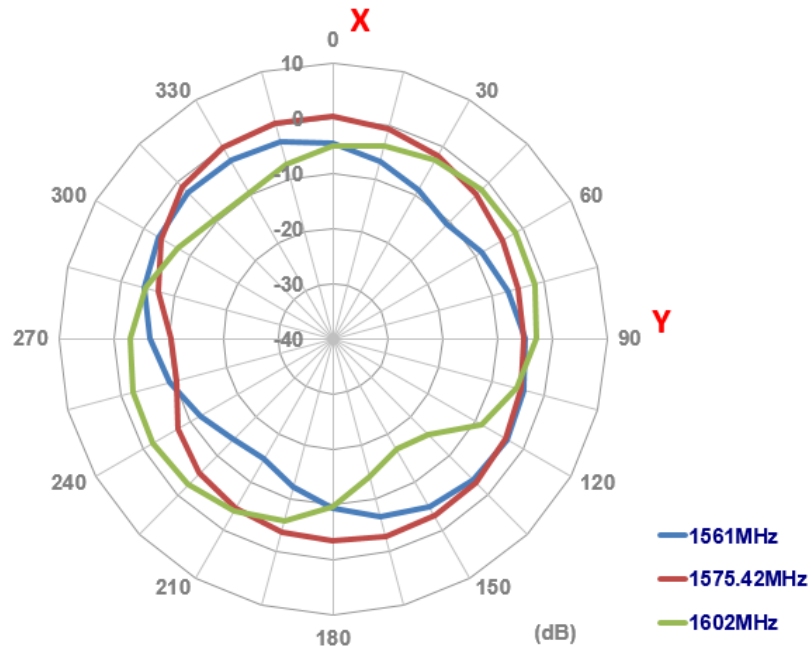

XZ Plane

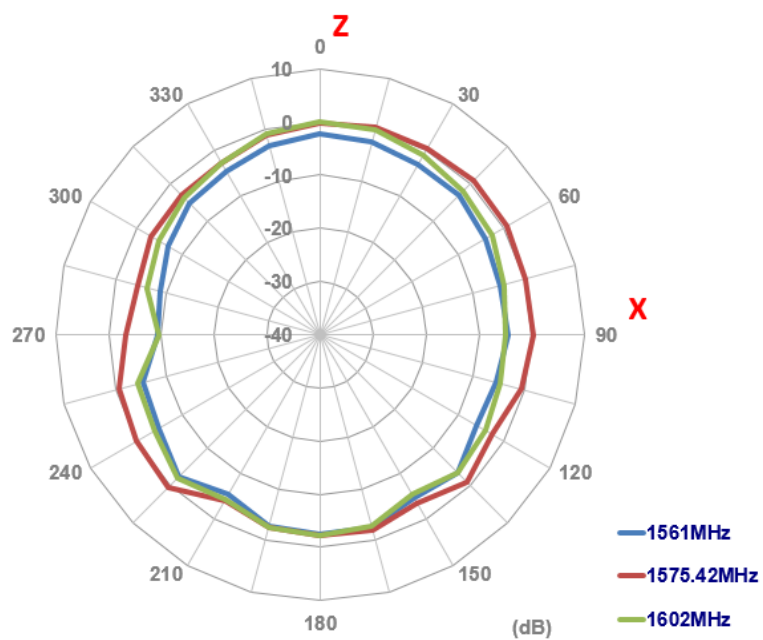

YZ Plane

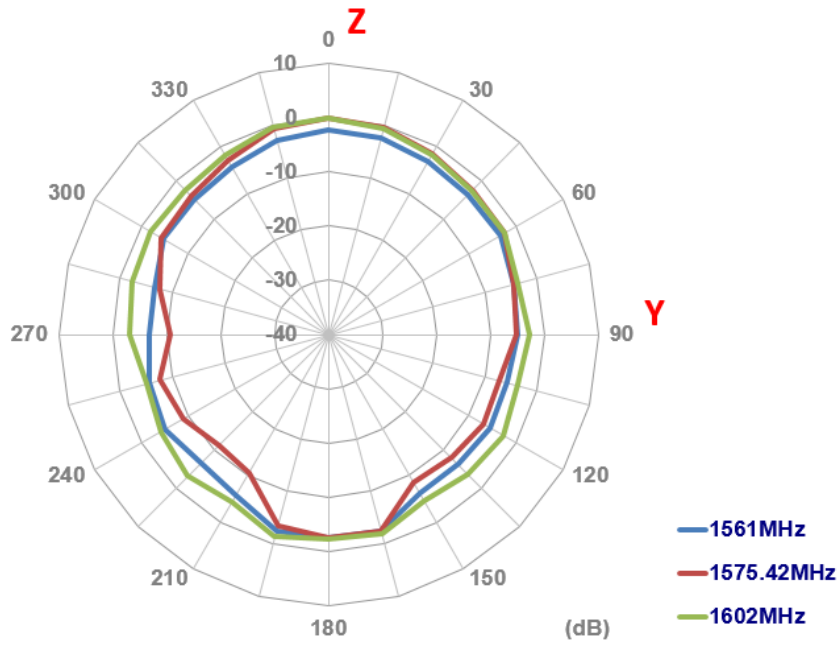

5.3. 3D Radiation Pattern

1561MHz

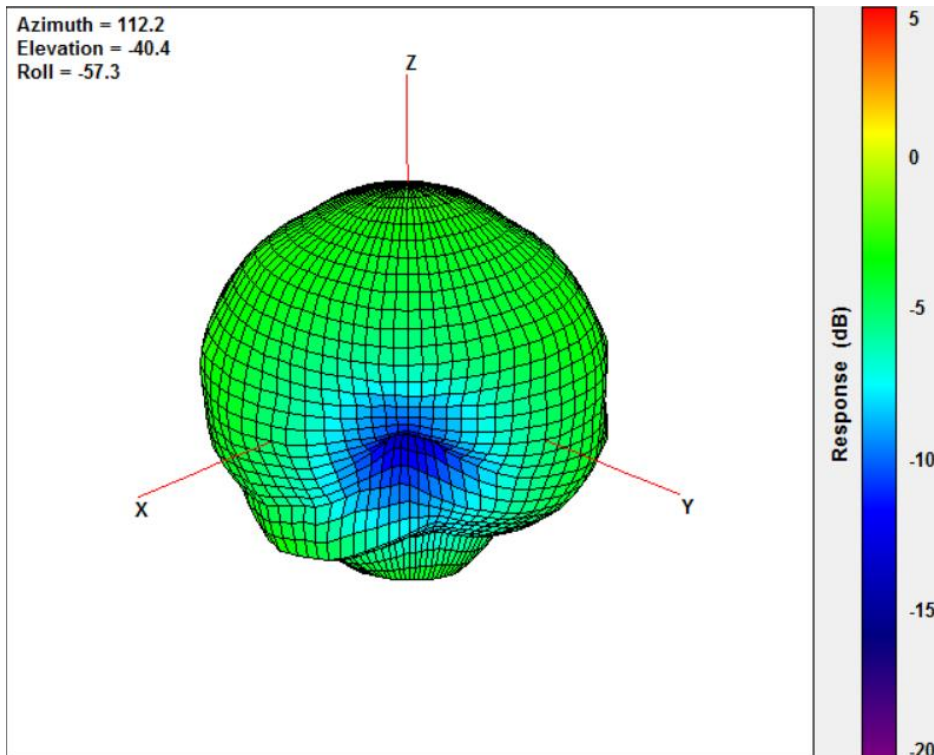

1575.42MHz

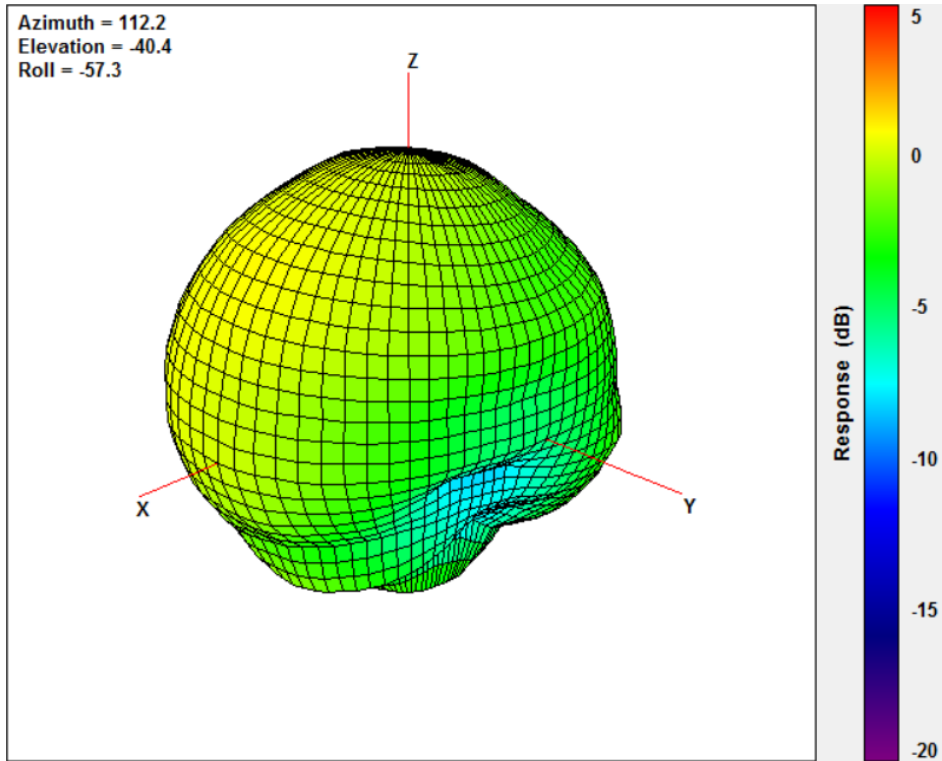

1602MHz

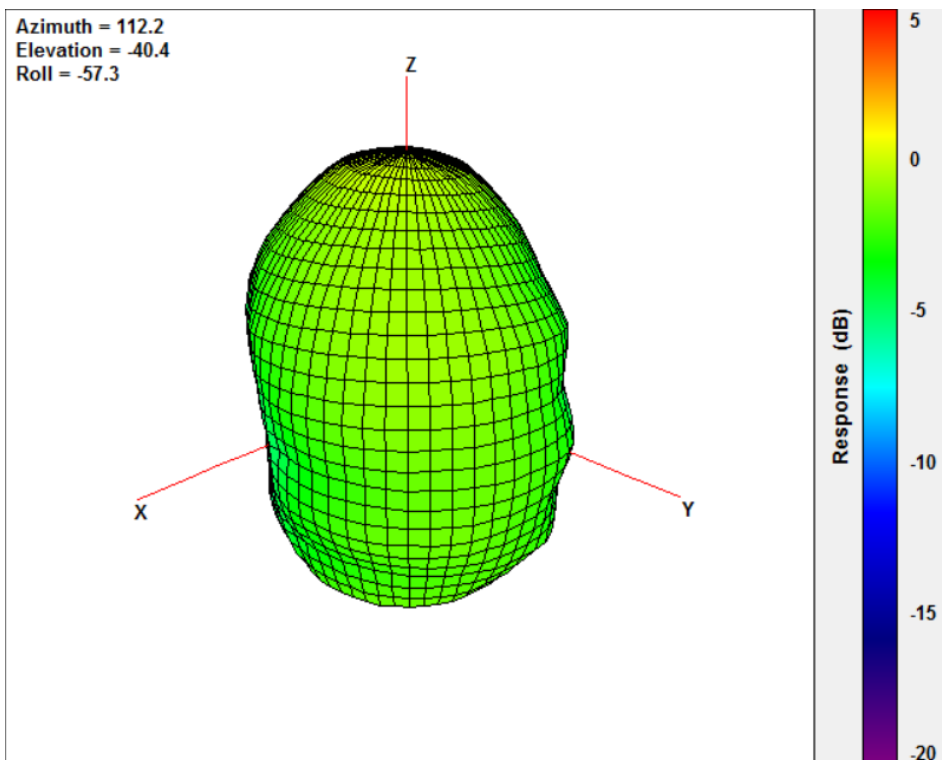

6. Connector Usage Precautions

Mating / unmating

(1) To disconnect connectors, insert the end portion of I-PEX under the connector flanges and pull off vertically, in the direction of the connector mating axis.

(2) To mate the connectors, the mating axes of both connectors must be aligned and the connectors can be mated. The "click" will confirm fully mated connection.

Do not attempt to insert on an extreme angle.

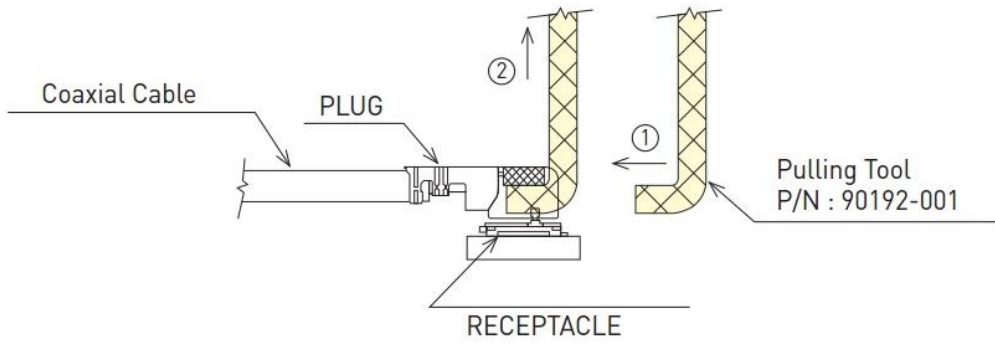

Pull forces on the cable after connectors are mated

After the connectors are mated, do not apply a load to the cable in excess of the values indicated in the diagram below.

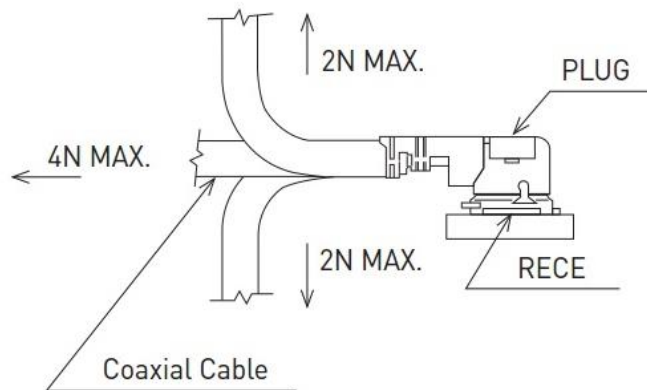

7. Mechanical Drawing

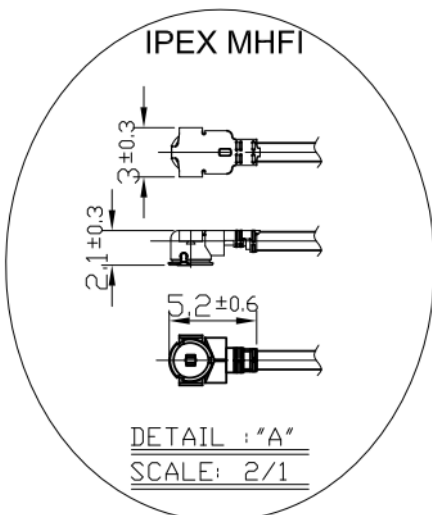
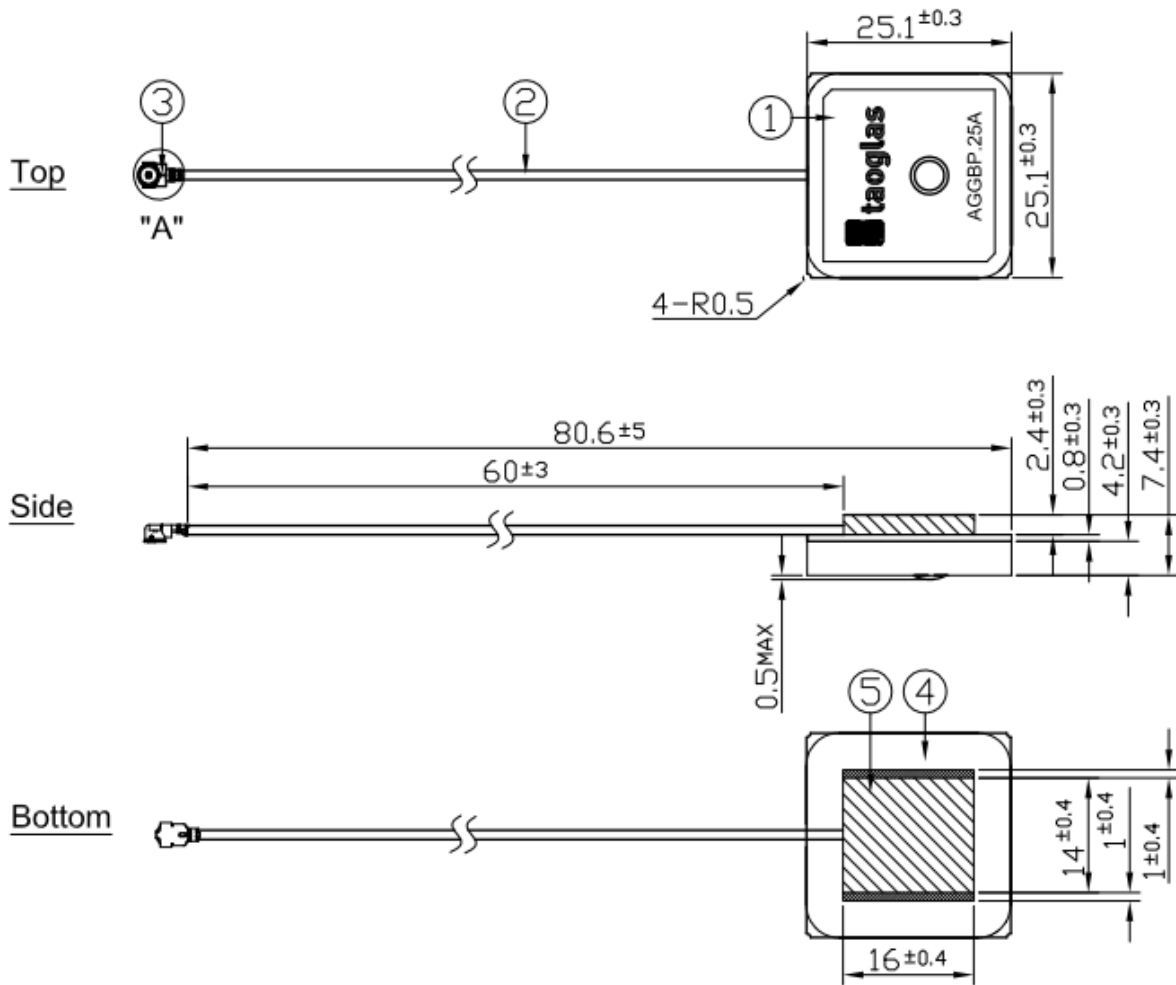

	Name	Material	Finish	QTY
1	Patch (25*25*4mm)	Ceramic	Clear	1
2	1.13 Coaxial Cable	FEP	Gray	1
3	IPEX MHF1	Brass	Gold	1
4	PCB	FR4 0.8t	Green	1
5	Shielding Case	(Tin)SPTE	Tin Plated	1

Unit:mm

8. Packaging

Packaging Specifications

30 pcs per tray
 5 Trays per PE bag
 Tray Dimensions - 370*305*25mm
 Weight - 430g

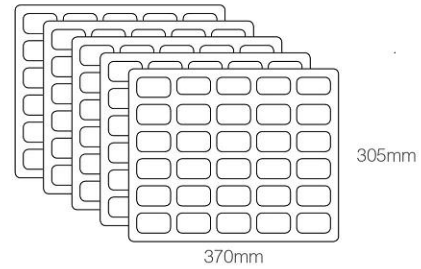

5 Trays per Carton - 150 pcs
 Carton Dimensions - 390*320*290mm

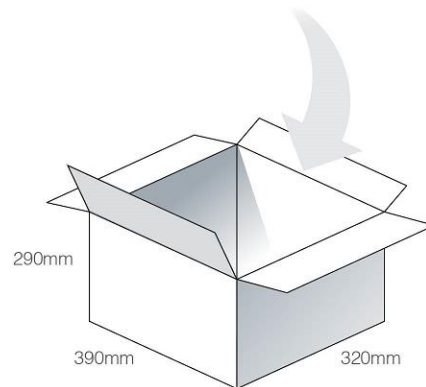

Pallet Dimensions 1100*1100*1310mm
 24 Cartons per Pallet
 4 Cartons per layer
 6 Layers

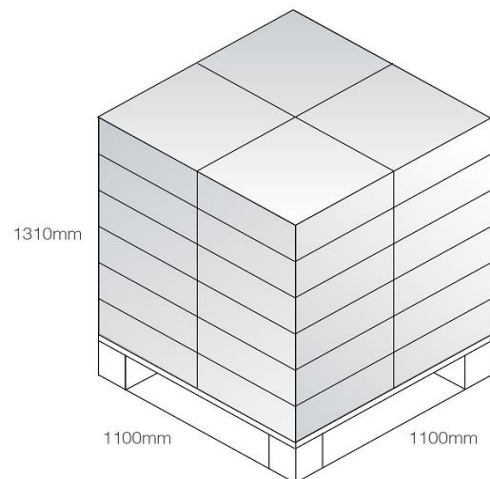

Taoglas makes no warranties based on the accuracy or completeness of the contents of this document and reserves the right to make changes to specifications and product descriptions at any time without notice. Taoglas reserves all rights to this document and the information contained herein.

Reproduction, use or disclosure to third parties without express permission is strictly prohibited.

Copyright © Taoglas Ltd.

X-ON Electronics

Largest Supplier of Electrical and Electronic Components

Click to view similar products for [Antennas](#) category:

Click to view products by [Taoglas](#) manufacturer:

Other Similar products are found below :

[GAN30084EU](#) [930-033-R](#) [GW17.07.0250E](#) [1513563-1](#) [EXE902SM](#) [APAMPG-117](#) [MAF94383](#) [W3908B0100](#) [W6102B0100](#) [YE572113-30RSMM](#) [108-00014-50](#) [66089-2406](#) [SPDA17RP918](#) [A09-F8NF-M](#) [A09-F5NF-M](#) [RGFRA1903041A1T](#) [W3593B0100](#) [W3921B0100](#) [SIMNA-868](#) [SIMNA-915](#) [SIMNA-433](#) [W1044](#) [W1049B090](#) [A75-001](#) [WTL2449CQ1-FRSMM](#) [CPL9C](#) [EXB148BN](#) [0600-00060](#) [TRA9020S3PBN-001](#) [Y4503](#) [GD5W-28P-NF](#) [MA9-7N](#) [GD53-25](#) [GD5W-21P-NF](#) [C37](#) [MAF94051](#) [MA9-5N](#) [EXD420PL](#) [B1322NR](#) [QWFTB120](#) [MAF94271](#) [MAF94300](#) [GPSMB301](#) [FG4403](#) [AO-AGSM-OM54](#) [5200232](#) [MIKROE-2349](#) [WCM.01.0111](#) [MIKROE-2393](#) [MIKROE-2352](#)