

SPECIFICATION

- Part No. : **AGGP.25F.07.0060A**
- Product Name : 25mm Two Stage GPS-GLONASS-GALILEO GNSS Active Patch
Antenna Module with Front-end Saw Filter
- Features : Industry leading GPS-GLONASS-GALILEO antenna performance
25.1*25.1*7.4mm (Ground Plane)
60mm Ø1.13 IPEX MHFI (U.FL)
28dB LNA
Wide Input Voltage 1.8V to 5.5V
Low Power Consumption
RoHS Compliant

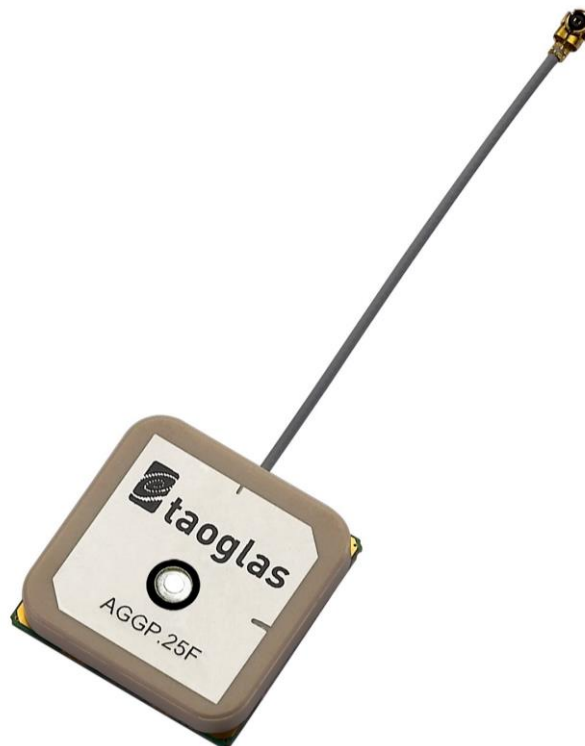

1. Introduction

The AGGP.25F GPS/GLONASS/GALILEO GNSS active patch antenna (along with the AGGP.35 model) is the best choice to use as an embedded antenna with the latest generation of GPS/GLONASS/GALILEO GNSS receivers. It utilizes a 25.1*25.1*4mm advanced wide-band ceramic patch antenna with optimized gain, radiation pattern and axial ratio at GPS, GLONASS and GALILEO centre frequencies.

The AGGP.25F also includes a two stage LNA and a front-end SAW filter to reduce out of band noise such as from nearby cellular transceiver, and improve probability of the wireless device passing radiated spurious emissions certification. Produced in TS16949 automotive quality approved facility and 100% tested for gain (S21), return loss (S11) to ensure total consistency of performance.

Cable type, length and connectors can be customized and samples offered according to requirement, subject to minimum order quantities in production. Taoglas also offers custom tuning service based on minimum order quantities, contact your local regional sales office for details.

The AGGP.25F consists of 2 functional blocks – the LNA and also the patch antenna.

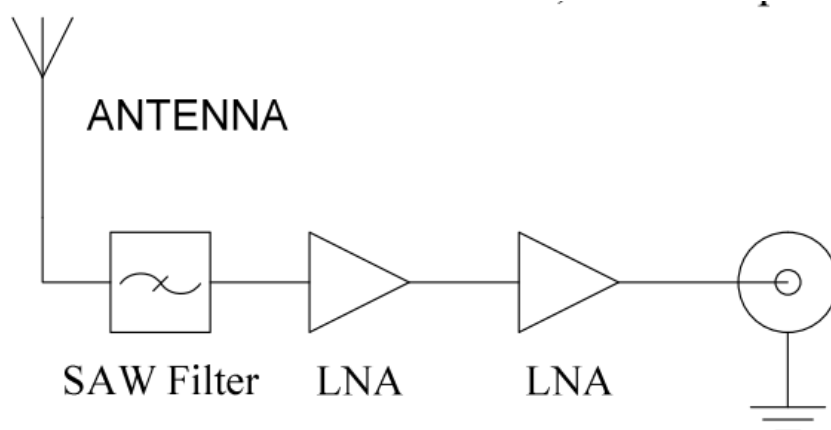

2. Specification

CERAMIC PATCH			
Frequency	1574~1610MHz		
Gain @ Zenith	1575.42MHz 1.5 dBic Typ. @ Zenith 1602MHz +0 dBic Typ. @ Zenith		
Gain at 90° with LNA	1575.42MHz: 26.5 ± 3dBic 1602MHz: 28 ± 3dBic		
Polarization	RHCP		
Axial Ratio	3.0dB max. @Zenith		
Patch Dimension	25.1*25.1*4mm		
LNA			
Frequency	1574~1610MHz		
Outer Band Attenuation	1592±140MHz 15dB min.		
Output Impedance	50Ω		
Output VSWR	2.0 Max		
Pout at 1dB Gain	Typ. -2dBm		
Compression point	Min. -6dBm		
Input Voltage	Min:1.8V Typ. 3.0V Max:5V		
LNA Gain, Power Consumption and Noise Figure			
Voltage	LNA Gain (Typ)	Power Consumption(mA) Typ	Noise Figure Typ
Min. 1.8V	22dB	5mA	2.6dB
Typ. 3.0V	28dB	10mA	2.6dB
Max. 5.5V	31dB	23mA	2.9dB
MECHANICAL			
Dimensions	25.1*25.1*7.4mm		
RF Cable	Coaxial Cable \varnothing 1.13 ± 0.1mm, length 60 ± 2.5mm		
Connector	IPEX MHFI (U.FL)		
ENVIRONMENTAL			
Operation Temperature	-40°C to + 85°C		
Storage Temperature	-40°C to + 85°C		
Relative Humidity	40% to 95%		

3. LNA Gain and Out Band Rejection @3.0V

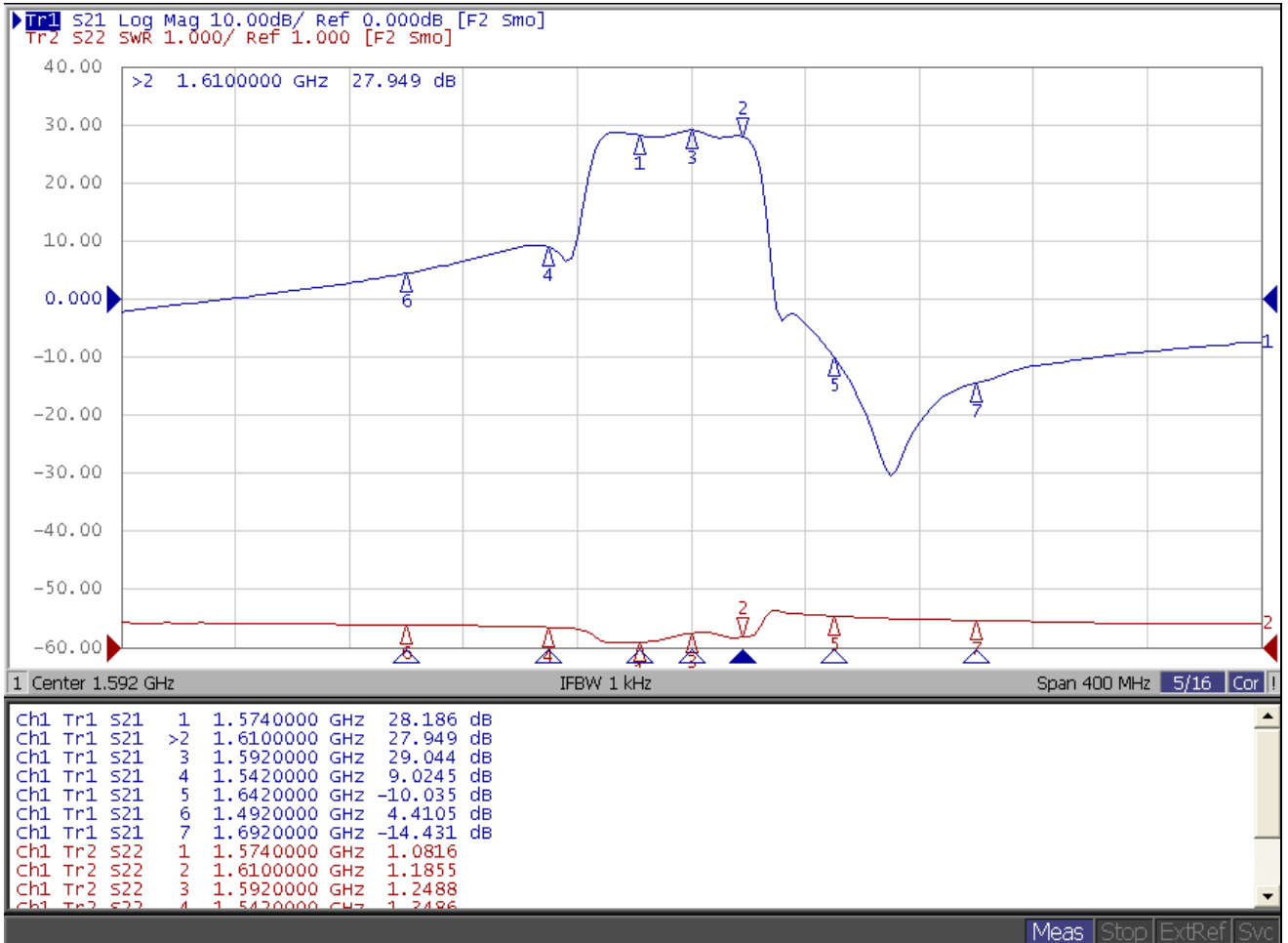

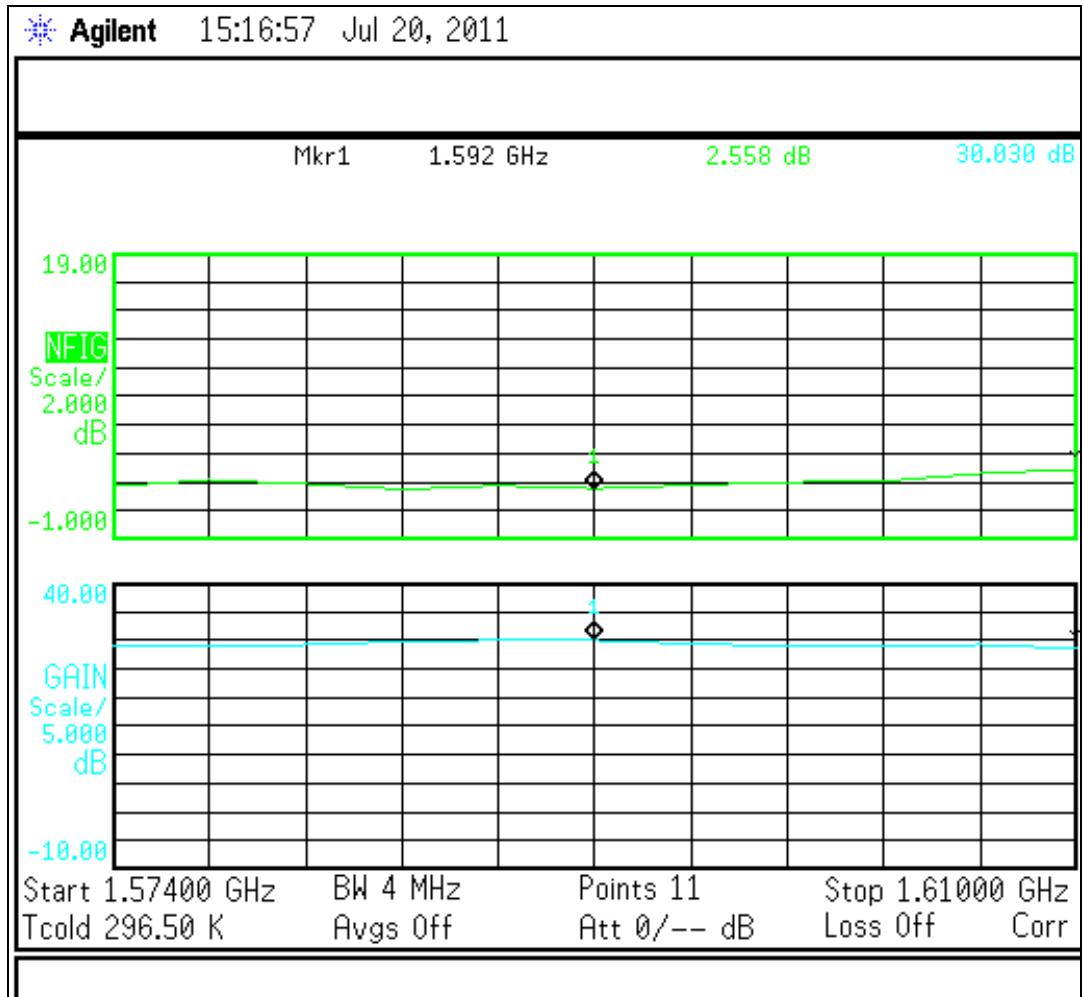

4. LNA Noise Figure @3.0V

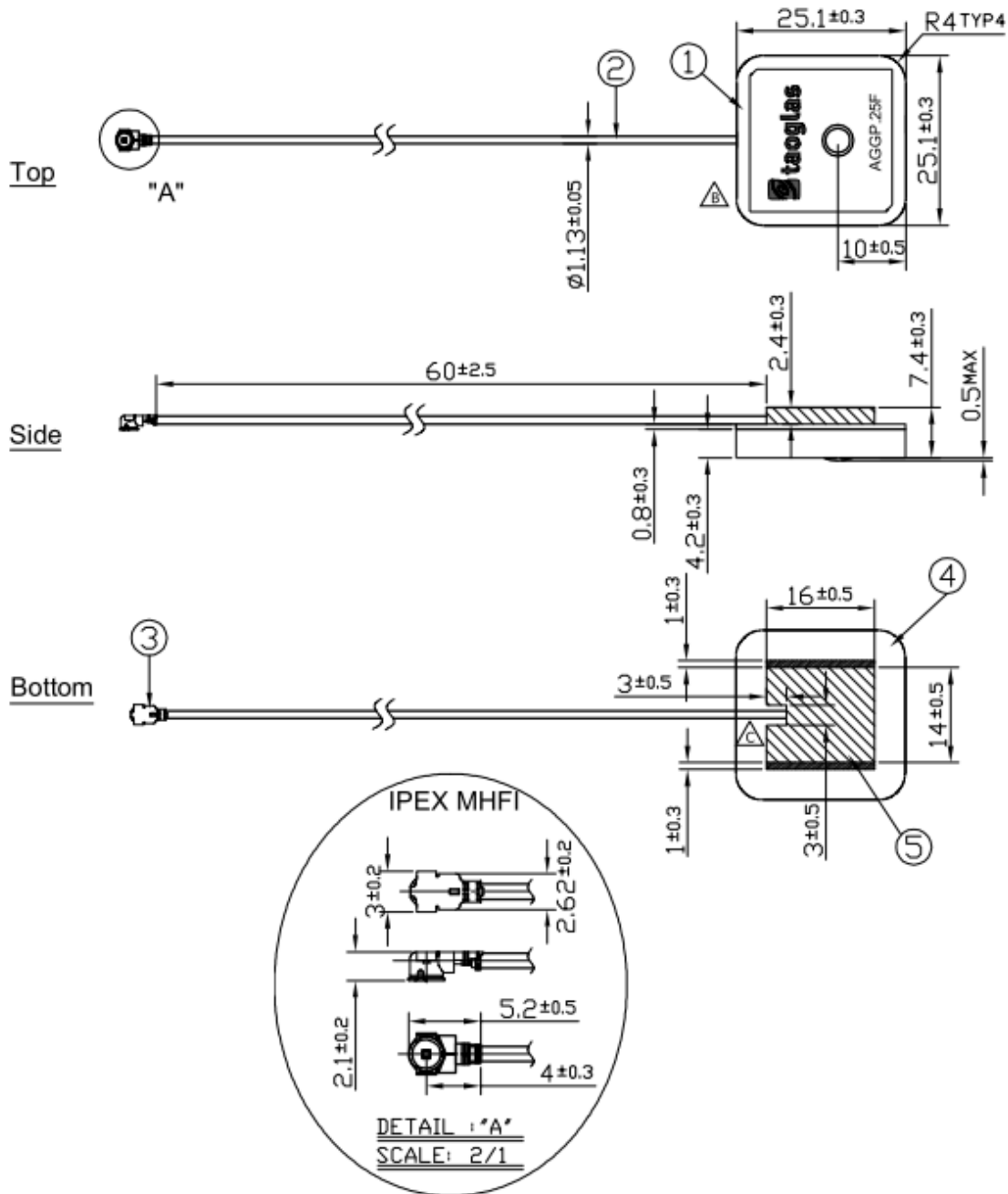

5. Technical Drawing



NOTE:	Name	P/N	Material	Finish	QTY
1.Soldered area 	1 AGGP.25F Patch(25*25*4.2mm)	AGGP.25F	Ceramic	Clear	1
2.Shielding case area 	2 1.13 Coaxial Cable	OD.113.CM	FEP	Gray	1
3.All material must be RoHS compliant.	3 IPEX MHF1 Connector	IPEX.MHF1.113	Brass	Gold	1
4.The connector orientation has a fixed position to the antenna as per drawing.	4 PCB		FR4 0.8t	Green	1
	5 Shielding Case		(Tin)SPTE	Tin Plated	1

6. Radiation Patterns

6.1. 1575.42MHz XZ & YZ Plane

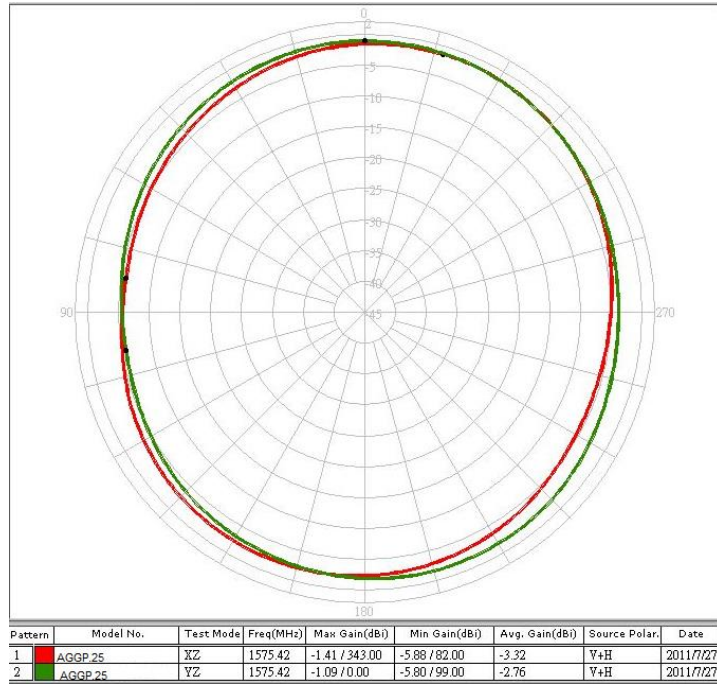

6.2. 1602MHz XZ & YZ Plane

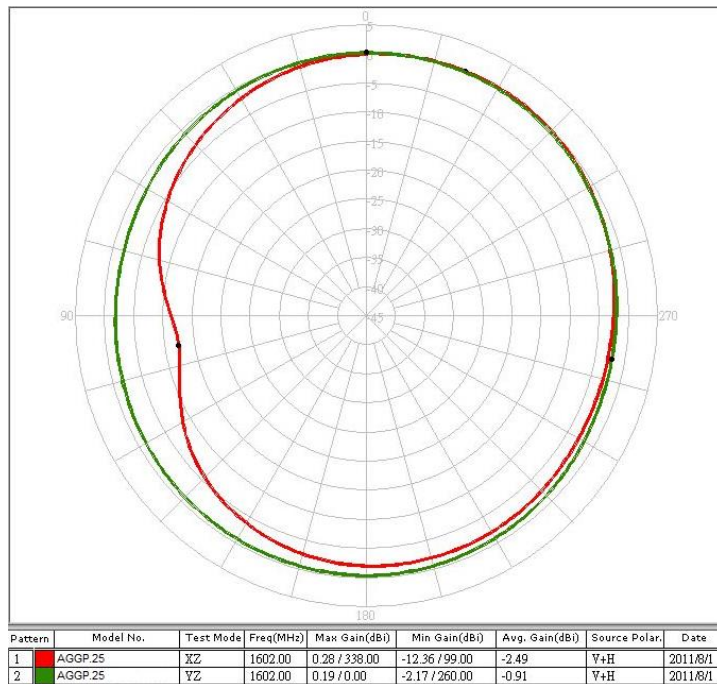

7. Plugs Usage Precautions

7.1. Mating / Unmating

- (1) To disconnect connectors, insert the end portion of I-PEX under the connector flanges and pull off vertically, in the direction of the connector mating axis.
- (2) To mate the connectors, the mating axes of both connectors must be aligned and the connectors can be mated. The "click" will confirm fully mated connection. Do not attempt to insert on an extreme angle.

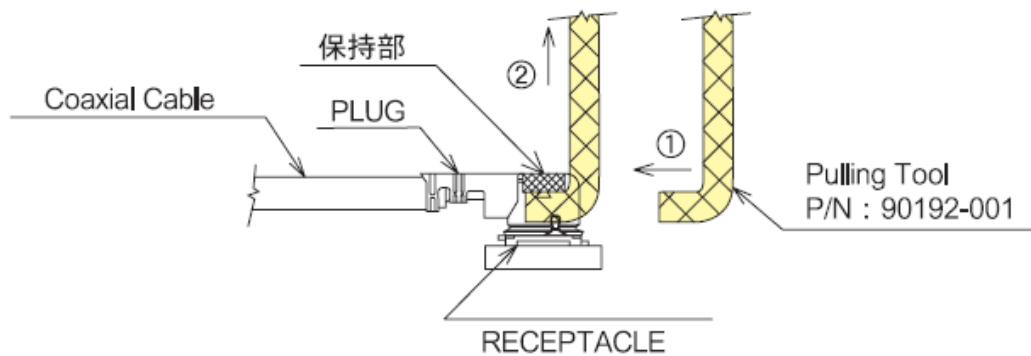

7.2. Pull forces on the cable after connectors are mated

After the connectors are mated, do not apply a load to the cable in excess of the values indicated in the diagram below.

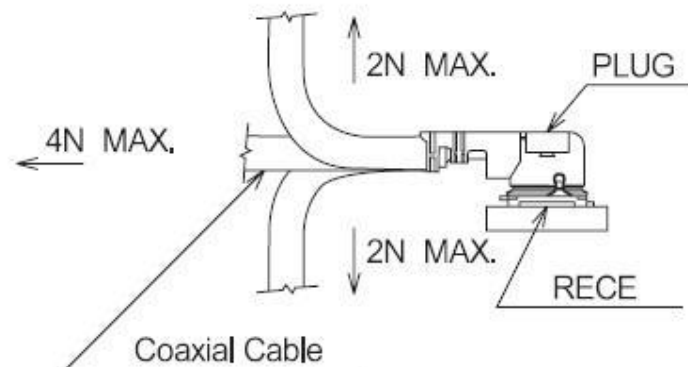

8. Packaging

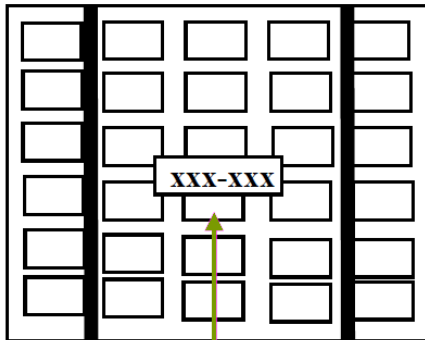

- *Packaged in Tray with Foam
- *One Tray = 60 pieces
- *6 Trays per Section = 360 pcs

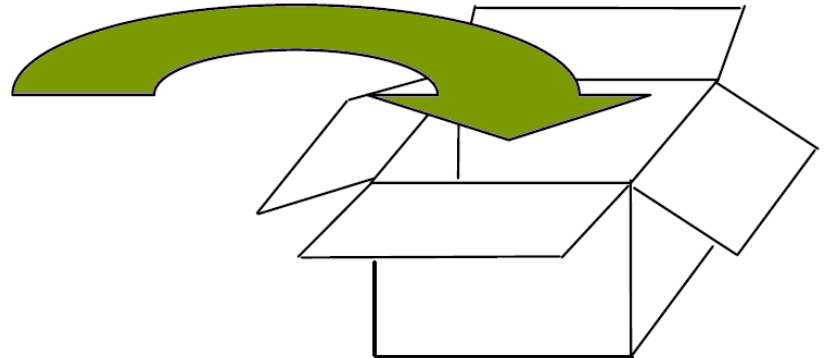

- *Each Carton contains 3 Sections
- *1080 pieces per Carton

Taoglas makes no warranties based on the accuracy or completeness of the contents of this document and reserves the right to make changes to specifications and product descriptions at any time without notice. Taoglas reserves all rights to this document and the information contained herein.

Reproduction, use or disclosure to third parties without express permission is strictly prohibited.

Copyright © Taoglas Ltd.

X-ON Electronics

Largest Supplier of Electrical and Electronic Components

Click to view similar products for [Antennas](#) category:

Click to view products by [Taoglas](#) manufacturer:

Other Similar products are found below :

[GAN30084EU](#) [930-033-R](#) [GW17.07.0250E](#) [1513563-1](#) [EXE902SM](#) [APAMPG-117](#) [MAF94383](#) [W3908B0100](#) [W6102B0100](#) [YE572113-30RSMM](#) [108-00014-50](#) [66089-2406](#) [SPDA17RP918](#) [A09-F8NF-M](#) [A09-F5NF-M](#) [RGFRA1903041A1T](#) [W3593B0100](#) [W3921B0100](#) [SIMNA-868](#) [SIMNA-915](#) [SIMNA-433](#) [W1044](#) [W1049B090](#) [A75-001](#) [WTL2449CQ1-FRSMM](#) [CPL9C](#) [EXB148BN](#) [0600-00060](#) [TRA9020S3PBN-001](#) [Y4503](#) [GD5W-28P-NF](#) [MA9-7N](#) [GD53-25](#) [GD5W-21P-NF](#) [C37](#) [MAF94051](#) [MA9-5N](#) [EXD420PL](#) [B1322NR](#) [QWFTB120](#) [MAF94271](#) [MAF94300](#) [GPSMB301](#) [FG4403](#) [AO-AGSM-OM54](#) [5200232](#) [MIKROE-2349](#) [WCM.01.0111](#) [MIKROE-2393](#) [MIKROE-2352](#)