

SPECIFICATION

- Part No. : **AP.25F.07.0078A**
- Product Name : 25mm Two Stage GPS/GALILEO Active Patch
Antenna Module with front-end Saw Filter
- Features : Industry leading GPS antenna performance
25mm*25mm*8mm (Ground Plane)
78mm Ø1.13 I-PEX MHFI (U.FL)
28dB LNA
Wide Input Voltage 1.8V to 5.5V
Low Power Consumption
ROHS Compliant



1. Introduction

The AP.25F has been designed specifically for embedded (inside device) integration with GPS /GALILEO receiver modules where there is a GSM transmitter nearby and risk of interference and saturation.

The AP.25F combines a 25*25*4mm advanced low profile ceramic patch antenna with a two stage LNA and a front-end SAW filter, with ultra thin coaxial cable.

Taoglas active antenna modules utilise XtremeGain™ technology for the highest sensitivity in the industry. The AP.25F consists of 2 functional blocks – the LNA and also the patch antenna.

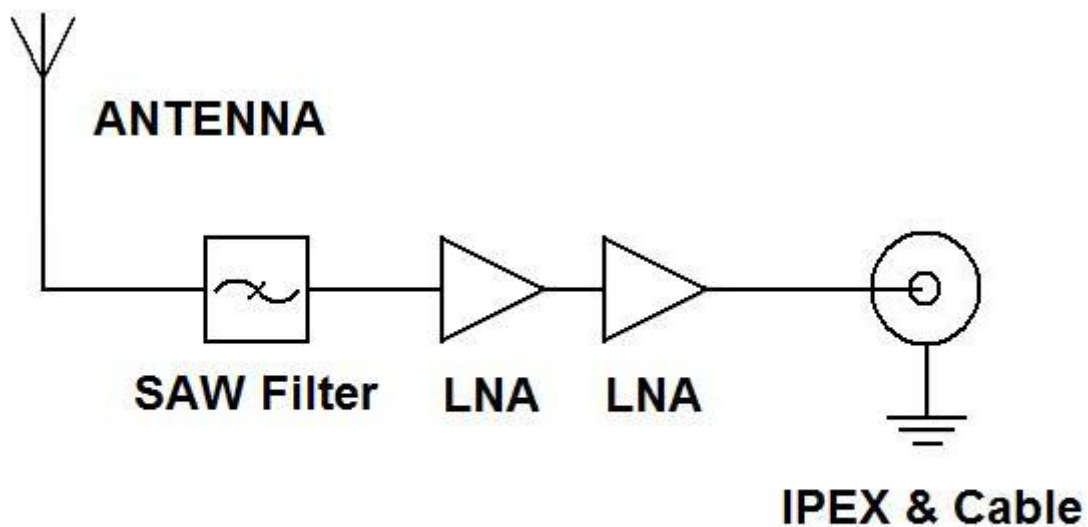

The AP.25F has a SAW filter on the front of it. The main use of the AP.25F would be for small devices where the GSM transmitter is close to the GPS/GALILEO antenna, it helps avoid burn-out of the LNA or the module due to interference from the GSM transmitter at out band frequencies.

2. Specification

2.1. Patch Antenna

Parameter	Specification
Frequency	1575.42 ± 1.023MHz
Gain @ Zenith	+2.0 dBic Typ. @ Zenith
Polarization	RHCP
Axial Ratio	3.0dB max. @Zenith
Patch Dimension	25*25*4mm

2.2. LNA

Parameter	Specification		
Frequency	1575.42 ± 1.023MHz		
Outer Band Attenuation	F0=1575.42MHz		
	F0±30MHz 5dB min.		
	F0±50MHz 20dB min.		
	F0±100MHz 25dB min.		
Output Impedance	50Ω		
Output VSWR	2.0 Max		
Pout at 1dB Gain Compression point	Typ. -2dBm Min. -6dBm		
LNA Gain, Power Consumption and Noise Figure			
	LNA Gain (Typ)	Power Consumption (mA) Typ	Noise Figure Typ
Min. 1.8V	23dB	Min. 3mA - Max. 10mA	2.7dB
Typ. 3.0V	28dB	Min. 8mA - Max. 20mA	3.0dB
Max. 5.5V	30dB	Min. 30mA - Max. 40mA	3.7dB

2.3. Cable* & Connector

Parameter	Specification
RF Cable	Coaxial Cable $\varnothing 1.13 \pm 0.1\text{mm}$, length $80 \pm 2.0\text{mm}$
Connector	IPEX MHFI (U.FL)

2.4. Total Specification (through Antenna, LNA, Cable and Connector)

Parameter	Specification
Frequency	$1575.42 \pm 1.023\text{MHz}$
Gain	At 3V: $30 \pm 3\text{dBi}$
Output Impedance	50Ω
Polarization	RHCP
Output VSWR	Max 2.0
Operation Temperature	-40°C to $+85^{\circ}\text{C}$
Storage Temperature	-40°C to $+85^{\circ}\text{C}$
Relative Humidity	40% to 95%
Input Voltage	Min:1.8V Typ. 3.0V Max:5V
Antenna	$25*25*8\text{mm}$

3. LNA Gain and Out Band Rejection @3.0V

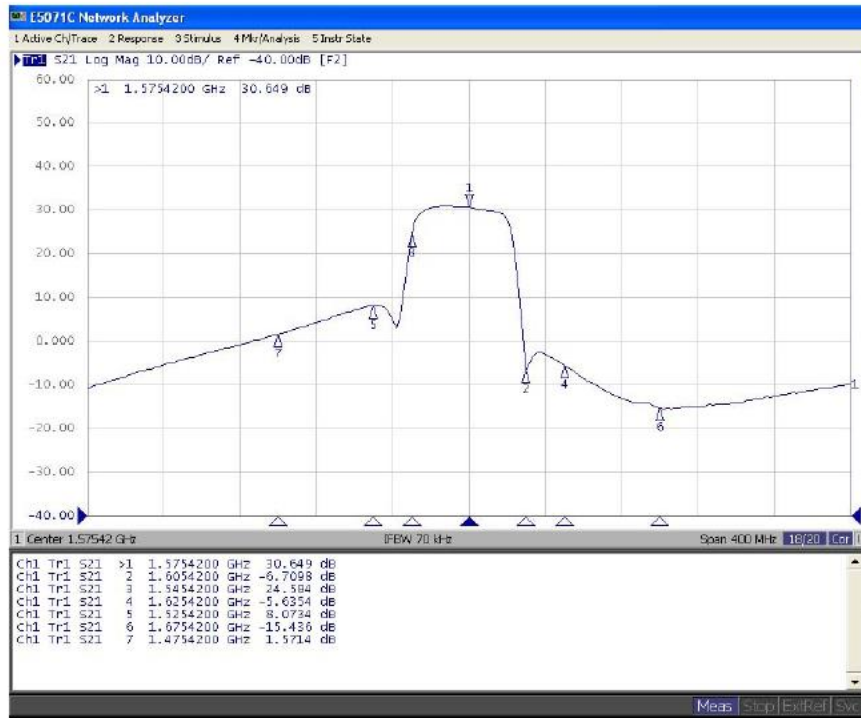

4. LNA Noise Figure @3.0V

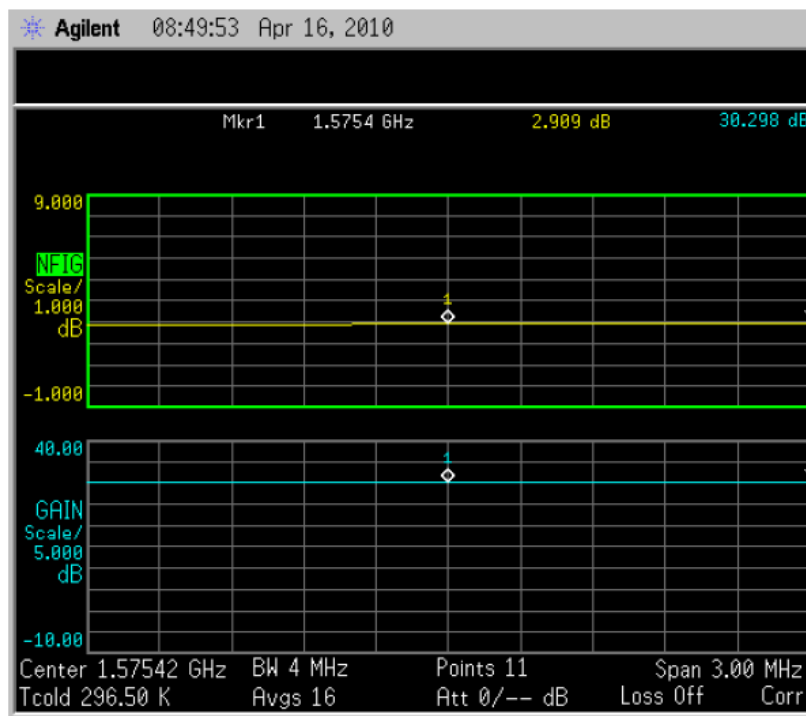

5. Mechanical Drawing (Unit: mm)

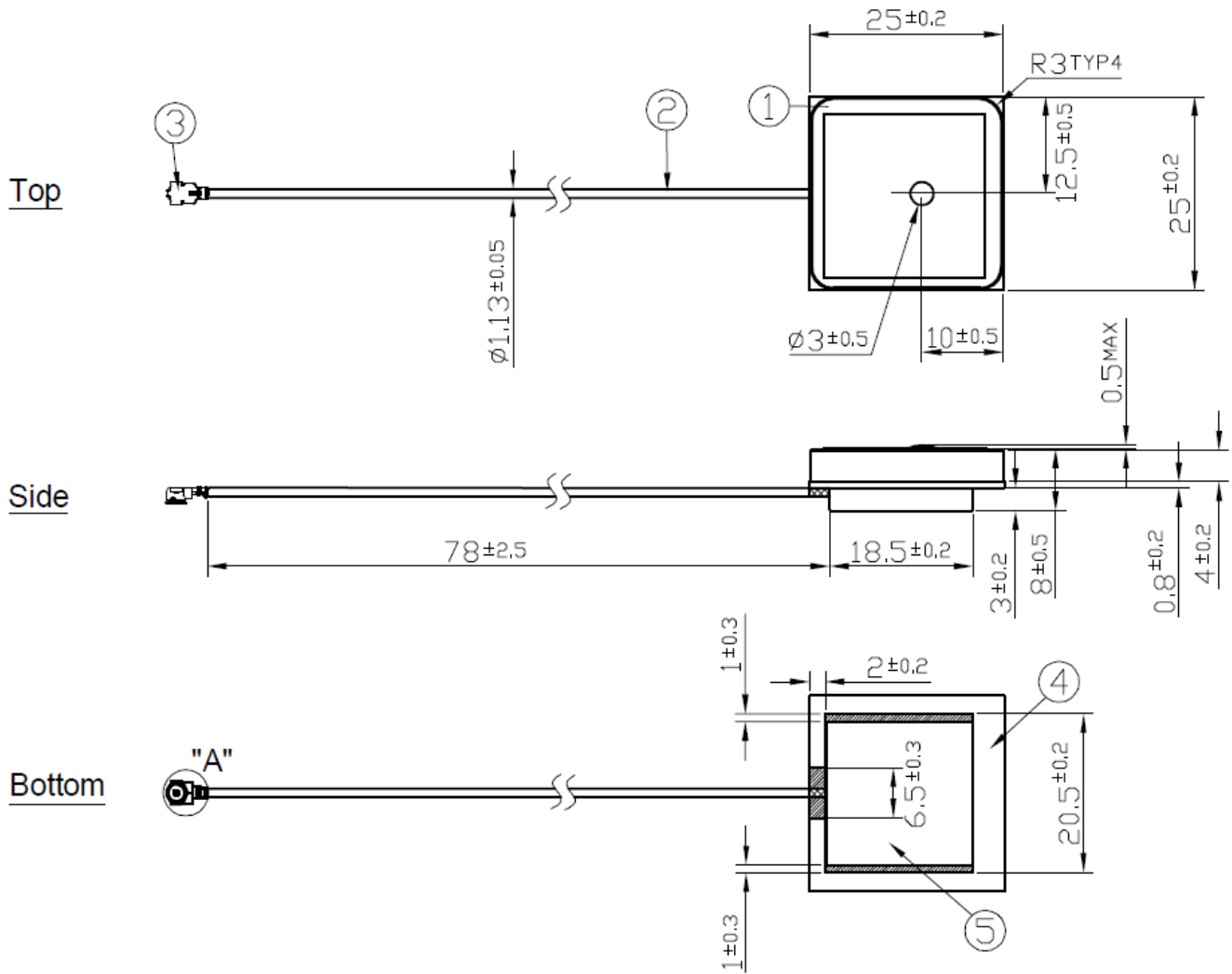

6. Radiation Patterns

XY Plane

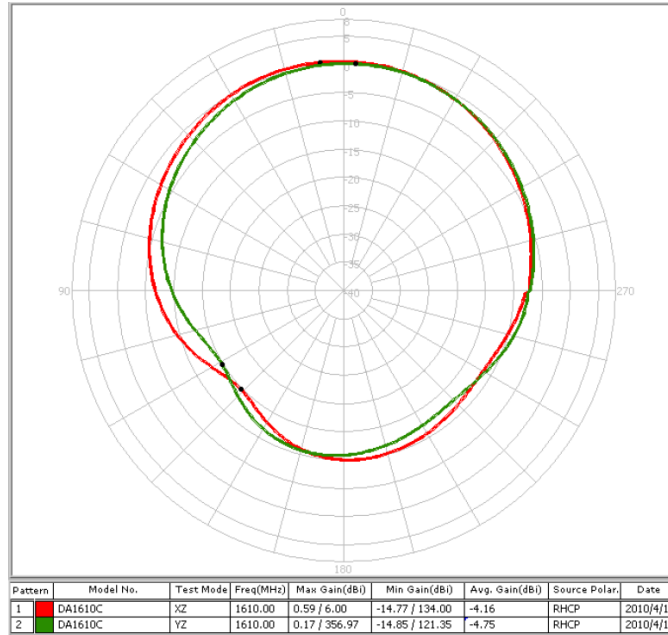

XZ Plane

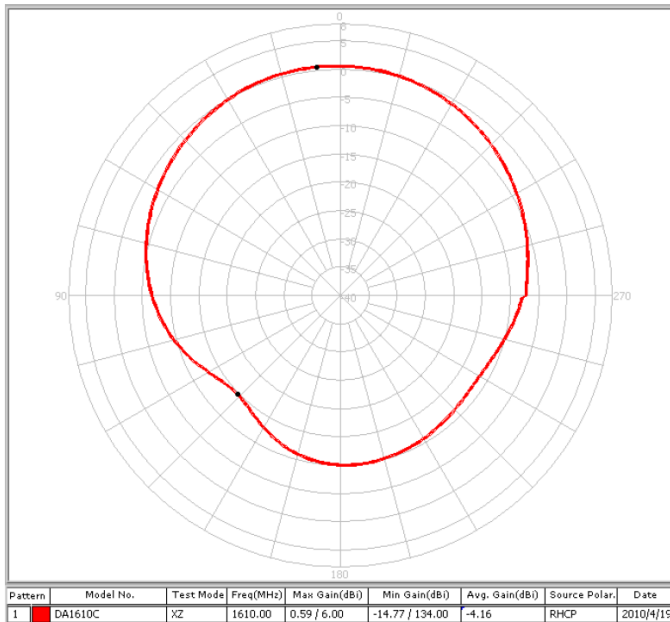

YZ Plane

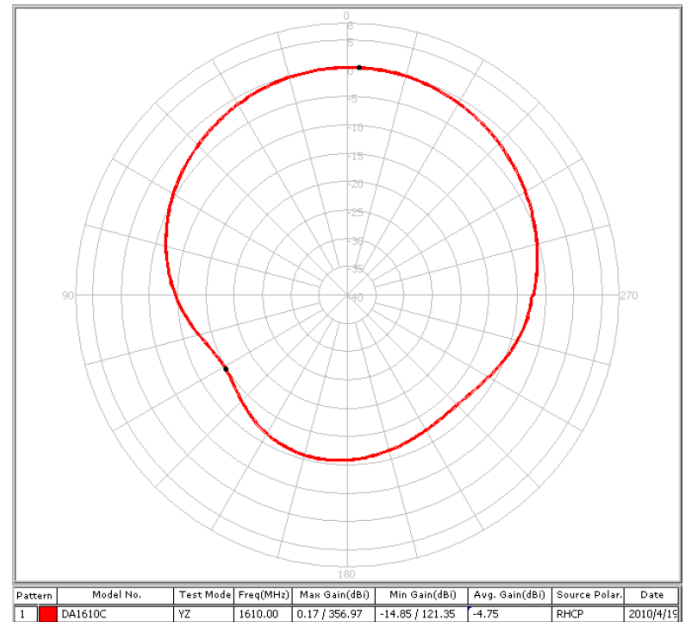

Taoglas makes no warranties based on the accuracy or completeness of the contents of this document and reserves the right to make changes to specifications and product descriptions at any time without notice. Taoglas reserves all rights to this document and the information contained herein.

Reproduction, use or disclosure to third parties without express permission is strictly prohibited.

Copyright © Taoglas Ltd.

X-ON Electronics

Largest Supplier of Electrical and Electronic Components

Click to view similar products for [Antennas](#) category:

Click to view products by [Taoglas](#) manufacturer:

Other Similar products are found below :

[GAN30084EU](#) [930-033-R](#) [GW17.07.0250E](#) [1513563-1](#) [EXE902SM](#) [APAMPG-117](#) [MAF94383](#) [W3908B0100](#) [W6102B0100](#) [YE572113-30RSMM](#) [108-00014-50](#) [66089-2406](#) [SPDA17RP918](#) [A09-F8NF-M](#) [A09-F5NF-M](#) [RGFRA1903041A1T](#) [W3593B0100](#) [W3921B0100](#) [SIMNA-868](#) [SIMNA-915](#) [SIMNA-433](#) [W1044](#) [W1049B090](#) [A75-001](#) [WTL2449CQ1-FRSMM](#) [CPL9C](#) [EXB148BN](#) [0600-00060](#) [TRA9020S3PBN-001](#) [Y4503](#) [GD5W-28P-NF](#) [MA9-7N](#) [GD53-25](#) [GD5W-21P-NF](#) [C37](#) [MAF94051](#) [MA9-5N](#) [EXD420PL](#) [B1322NR](#) [QWFTB120](#) [MAF94271](#) [MAF94300](#) [GPSMB301](#) [FG4403](#) [AO-AGSM-OM54](#) [5200232](#) [MIKROE-2349](#) [WCM.01.0111](#) [MIKROE-2393](#) [MIKROE-2352](#)