



TAOGLAS®



Datasheet

Flexible NFC Antenna

Part No:
FXR.07.52.0075X.A

Description:

Circular Flexible Near-Field Communications Antenna with 75mm Twisted Pair 28AWG Cable and ACH(F) connector

Features:

- 13.56 MHz Antenna
- Flexible Low Profile Embedded Antenna
- Diameter: 45.5 mm
- Thickness: 0.24 mm
- Peel and stick 3M adhesive on back
- 75mm Twisted Pair 28AWG Cable with Teflon and ACH(F) Connector
- RoHS & Reach Compliant

1. Introduction	3
2. Specifications	4
3. Antenna Applications	5
4. Mechanical Drawing	9
5. Packaging	10
<hr/>	
Changelog	11

Taoglas makes no warranties based on the accuracy or completeness of the contents of this document and reserves the right to make changes to specifications and product descriptions at any time without notice. Taoglas reserves all rights to this document and the information contained herein. Reproduction, use or disclosure to third parties without express permission is strictly prohibited.



1. Introduction



The FXR.07.52.0075X.A is a circular, flexible, NFC (Near Field Communications) antenna for use in mobile devices and other applications such as keycards, payment systems, and boarding passes. The design provides a flexible NFC antenna with 75mm twisted pair 28AWG cable that can be adhered to the plastic enclosure of the device for ease of installation and work with specific 13.56MHz RFID and NFC chips which need to connect via JST ACH connector.

With NFC antennas being commonly attached to the battery of mobile devices, they can be customized with a ferrite flux director to provide isolation from the battery or other components within the device. Using the antenna on a conductive surface without a ferrite layer will result in extremely short range or complete failure to communicate. The coil inductance noted below can help estimate a capacitance value for creating resonance at 13.56MHz.

Typical applications

- Mobile devices
- Electronic wallets
- Health care ID scanners
- Payment readers
- Office ID
- Access control
- Internet Of Things

The cable and connector are fully customizable, for further information please contact your regional Taoglas customer support team.

2. Specifications

Electrical	
Frequency	13.56MHz
Return Loss	>10 dB
Polarization	Linear
Impedance	50 Ω
Self Resistance Frequency	36.86
Q Factor	64
Ls	6.78uH
Rs	2.2

* All Testing was done using a Agilent 4285A LCR Meter calibrated at 13.56MHz.

** Testing was completed using series mode, but were was conducted using parallel method as well.

Mechanical	
Antenna Dimensions	\varnothing 45.5mm x 36.8mm
Connector	ACH(F)
Standard Cable	75mm Twisted Pair 28AWG Cable
Adhesive	3M 467
RoHS Compliant	Yes
REACH Compliant	Yes

Environmental	
Temperature Range	-40°C to 85°C

3. Antenna Applications

3.1 Test Set up

A test fixture is used to measure the maximum interrogation distance. The FXR.07.52.0075.A antenna is connected to a NFC evaluation board and then placed on the fixed part of the fixture.

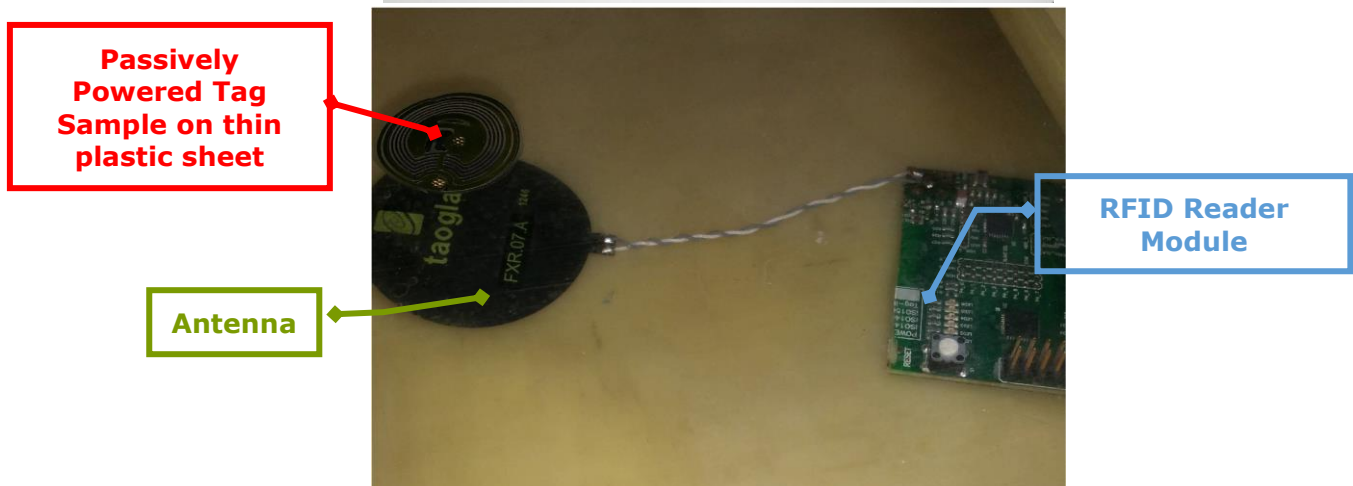
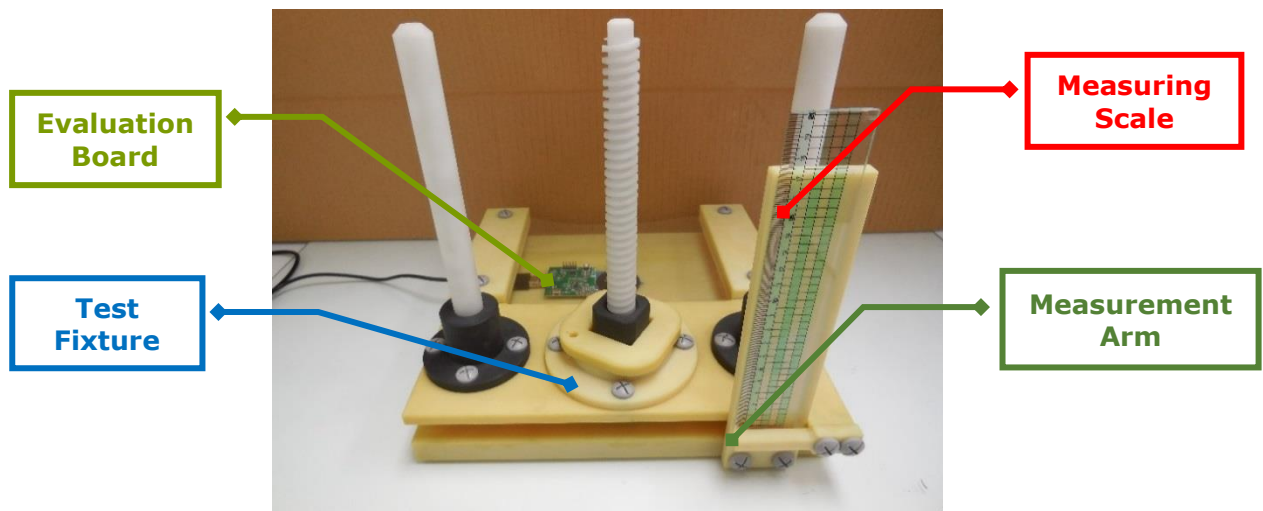

The test sample is placed on a thin sheet of plastic connected to the movable part of the fixture. Then the distance is carefully adjusted until the reader can no longer read the sample, thus the maximum interrogation distance is displayed in the ruler.

3.2 RFID tags used for test

A total of 8 RFID tags were used to measure the interrogation distances. The next picture shows type 1 and type 2 respectively.

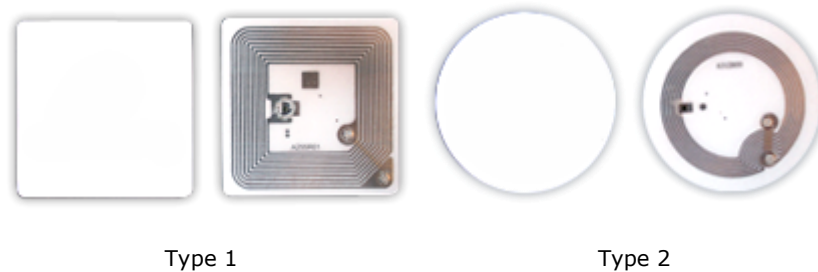

Type 1 tag is based on ISO/IEC 14443A standard and has 512 bytes of memory.

Type 2 tag is based on ISO/IEC 14443A standard and has 192 bytes of memory.

The next picture shows the Tag-it HF-I RFID tags from Texas Instruments: RI-102-112, RI-111-112, RI-103-112, RI-116-112, button type, and RI-117-112.

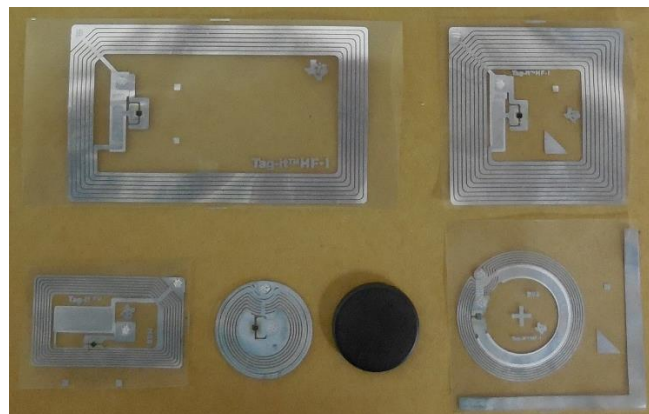

The Tag-it HF-I Plus Transponder Inlay family of Texas Instruments RFID is based on the ISO/IEC 15693 standard for contactless integrated circuit cards (vicinity cards) and ISO/IEC 18000-3 standard for item management.

3.3 Matching

The interrogation distances presented here were taken with the antenna connected directly to the evaluation boards with the default matching circuit. This is not necessarily the optimal matching circuit that could be designed for a particular antenna. We kept the default matching of each evaluation board to minimize the number of variables in testing and keep integration as simple as possible.

As with any matching network the exact circuit and values for an optimal network depend on the combination of antenna, NFC circuit, any intervening transmission line and the environment presented to the antenna. These factors are specific to the particular end product.

As a starting point, to achieve the read range results presented here, use the matching network detailed in the schematic of the evaluation board for your particular NFC chip and keep the antenna free of any obstruction. Once you can demonstrate successful reads you can then optimize performance as desired.

If the matching network is required, you should implement the following topology:

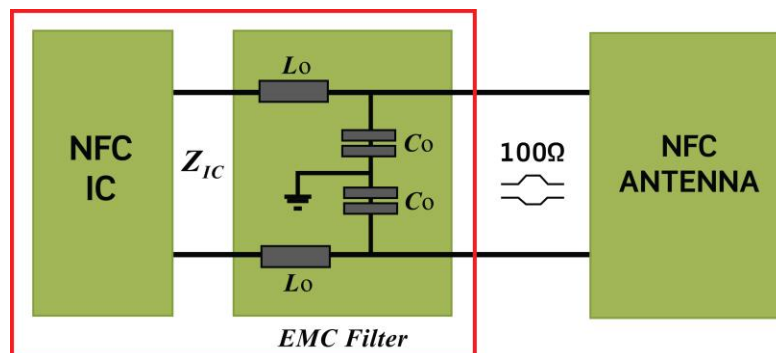

The matching circuit should be designed to match the IC impedance Z_{IC} to 100Ω and then connect the antenna through a 100Ω differential pair.

3.4 Test Results

A total of 8 sample devices were used to measure the interrogation distances in two scenarios, over plastic and over metal, using the Texas Instruments TRF7970AEVM evaluation board. The results are:

- Over plastic:

RFID Tag	Dimensions (mm)	Interrogation Distance (mm)
Topaz512 (Type 1)	43 x 43	19
NTAG203 (Type 2)	Φ 42	21
Tag-it HFI Plus RI-I11-112	45 x 45	31
Tag-it HFI Plus RI-I02-112	76 x 48	30
Tag-it HFI Plus RI-I03-112	38 x 22.5	15
Tag-it HFI Plus RI-I16-112	Φ 24.2	20
Button type	Φ 22	19
Tag-it HFI Plus RI-I17-112	Φ 32.5	24

- Over Metal:

RFID Tag	Dimensions (mm)	Interrogation Distance (mm)
Topaz512 (Type 1)	43 x 43	15
NTAG203 (Type 2)	Φ 42	16
Tag-it HFI Plus RI-I11-112	45 x 45	21
Tag-it HFI Plus RI-I02-112	76 x 48	25
Tag-it HFI Plus RI-I03-112	38 x 22.5	10
Tag-it HFI Plus RI-I16-112	Φ 24.2	13
Button type	Φ 22	15
Tag-it HFI Plus RI-I17-112	Φ 32.5	16

4. Mechanical Drawing (Units: mm)

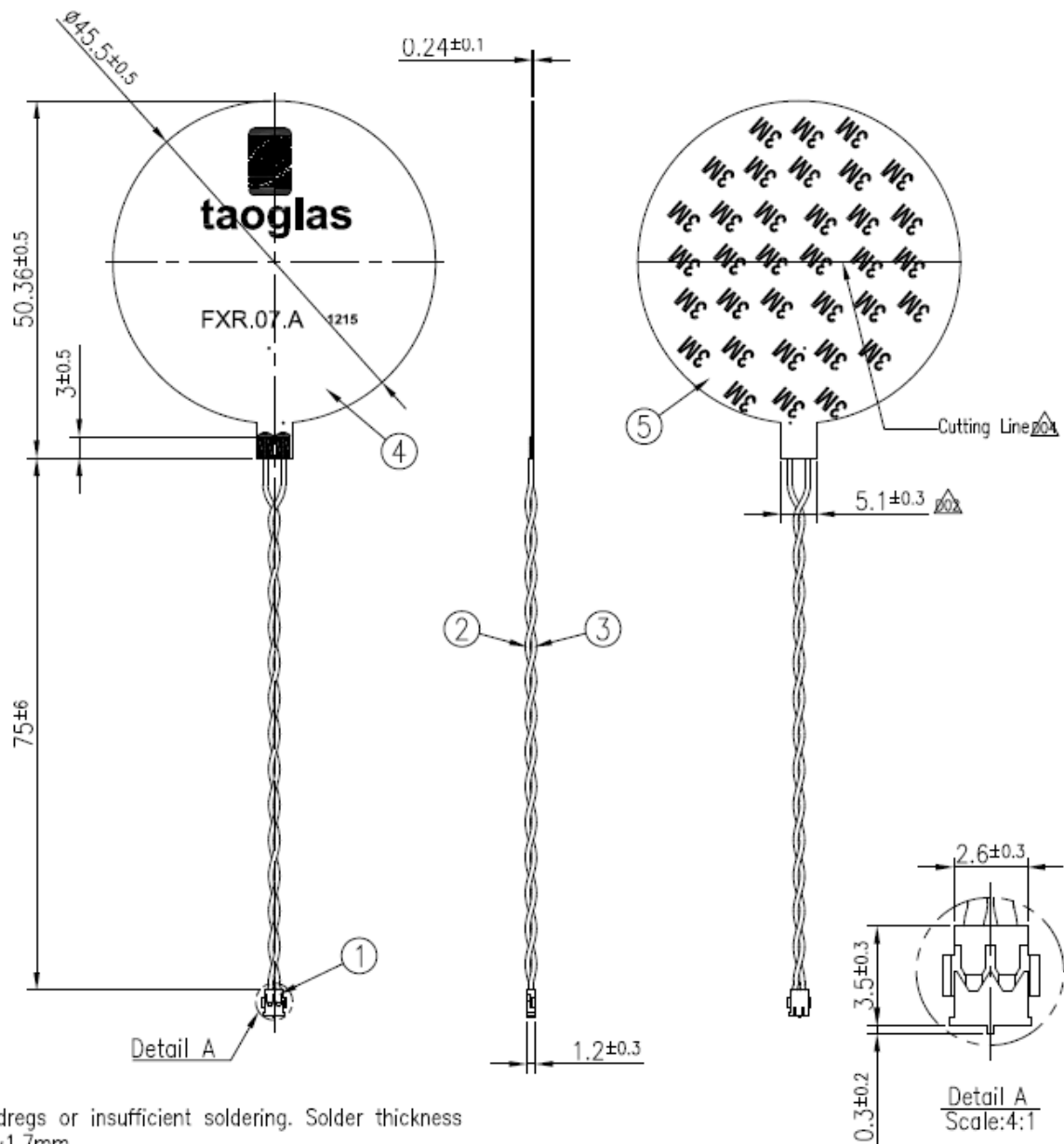

Notes:

1. No dregs or insufficient soldering. Solder thickness 0.3~1.7mm
2. The solder must be smooth and full to the edges of the pad, and must not extend outside of the pad area.
3. The connector position has special orientation to the PCB as per drawing.
4. All Material Must Be RoHS Compliant.
5. Open/short QC, VSWR required.
6. Soldered area (Tin Plated).

	Name	P/N	Material	Finish	QTY
1	ACH Connector (F)	208115C000000A	Engineering Plastics	Black	1
2	PVDF Cable (28AWG)	304515C000000A	PVDF	Black	1
3	PVDF Cable (28AWG)	304515C010000A	PVDF	Red	1
4	FXR.07.A.FPCB	100112G000033A	Polymer 0.15t	Black	1
5	Double-Sided Adhesive	100112G000033A	3M 467	Brown Liner	1

5. Packaging

FXR.07.52.0075X.A

Packaging Specifications

100pcs FXR.07.52.0075X.A per PE Bag
 Bag Dimensions - 187 x 137mm
 Weight - 176g

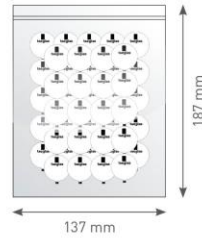

1000pcs FXR.07.52.0075X.A per PE Large Bag
 Bag Dimensions - 470 x 380mm
 Weight - 1.76Kg

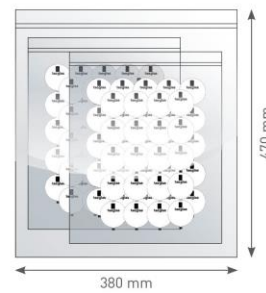

Carton Qty - 5,000 FXR.07.52.0075X.A
 Carton - 330 x 260 x 240mm
 Weight - 9.3Kg

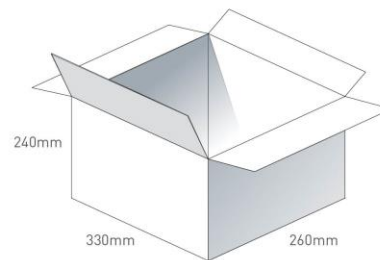

Pallet Dimensions 1200 x 1000 x 1350mm
 60 Cartons per Pallet
 12 Cartons per layer
 5 Layers

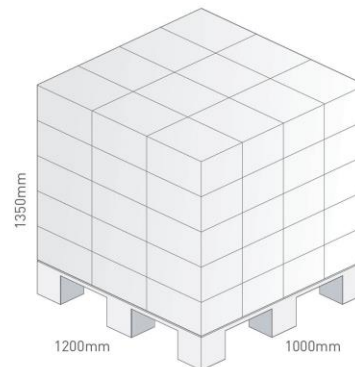

Changelog for the datasheet

SPE-15-8-077 – FXR.07.52.0075X.A

Revision: C (Current Version)

Date:	2021-04-14
Changes:	New Values Added
Changes Made by:	Jack Conroy

Previous Revisions

Revision: B

Date:	2017-07-17
Changes:	PCN-17-8-104
Changes Made by:	Andy Mahoney

Revision: A (Original First Release)

Date:	2015-12-22
Notes:	
Author:	Jack Conroy



TAOGLAS®

www.taoglas.com



X-ON Electronics

Largest Supplier of Electrical and Electronic Components

Click to view similar products for [Antennas](#) category:

Click to view products by [Taoglas](#) manufacturer:

Other Similar products are found below :

[GAN30084EU](#) [930-033-R](#) [GW17.07.0250E](#) [1513563-1](#) [EXE902SM](#) [APAMPG-117](#) [MAF94383](#) [W3908B0100](#) [W6102B0100](#) [YE572113-30RSMM](#) [108-00014-50](#) [66089-2406](#) [SPDA17RP918](#) [A09-F8NF-M](#) [A09-F5NF-M](#) [RGFRA1903041A1T](#) [W3593B0100](#) [W3921B0100](#) [SIMNA-868](#) [SIMNA-915](#) [SIMNA-433](#) [W1044](#) [W1049B090](#) [A75-001](#) [WTL2449CQ1-FRSMM](#) [CPL9C](#) [EXB148BN](#) [0600-00060](#) [TRA9020S3PBN-001](#) [GD5W-28P-NF](#) [MA9-7N](#) [GD53-25](#) [GD5W-21P-NF](#) [C37](#) [MAF94051](#) [MA9-5N](#) [EXD420PL](#) [B1322NR](#) [QWFTB120](#) [MAF94271](#) [MAF94300](#) [GPSMB301](#) [FG4403](#) [AO-AGSM-OM54](#) [5200232](#) [MIKROE-2349](#) [WCM.01.0111](#) [MIKROE-2393](#) [MIKROE-2352](#) [MIKROE-2350](#)