

SPECIFICATION

- Part No. : **ISA.01.A.301111**
- Product Name : Wide-band Omni-directional Low Profile 400~470MHz Adhesive
Glass Mount Antenna
- For ISM/ TETRA/CDMA 450/ SCADA
Family Radio Service/General Mobile Radio Service/Bio-Medical
Telemetry
- Features : 239mm x 42mm x 11mm
1.5dBi gain, 35%+ efficiency
Omni-Directional
Stable Wide-band response from 400Mhz to 470MHz
Semi-Flexible, Low profile IP67 Waterproof Housing
Standard 3 meters RG174 cable
Automotive Approved 3M Adhesive
SMA (M) Connector
RoHS Compliant

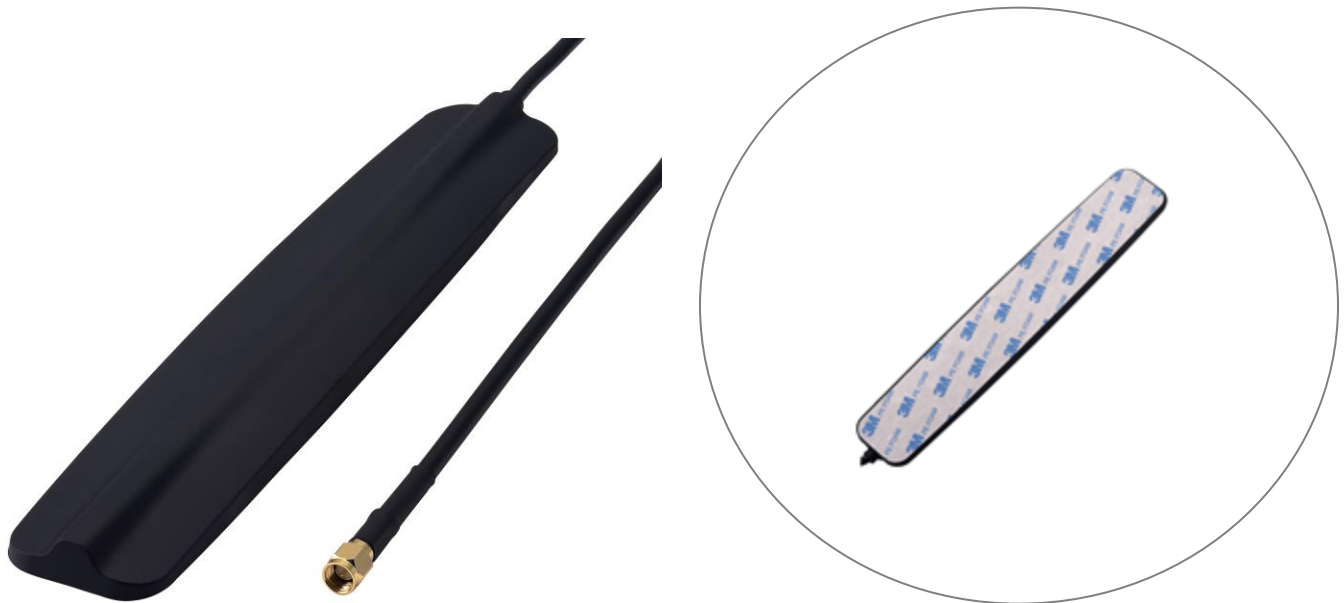

1. Introduction

The ISA.01 is an Omni-directional wide-band low profile 400MHz to 470MHz antenna for internal or external applications adhesive mounted on glass.

Its applications are in the automotive industry and telematics. At only 10.5mm thick and 42mm in width, its semi-flexible properties and strong 3M automotive approved double-sided adhesive allows for convenient glass installation. ISA.01 antenna offers exceptionally stable peak gain and efficiency across a very wide bandwidth, tuned to operate optimally on glass, which makes it a unique low frequency solution in low profile form. Unlike our competitors, Taoglas shows full performance data for our antennas. The ISA.01 shows real gain figures and radiation patterns INCLUDING cable losses, tested in state of the art low frequency anechoic chambers. We have invested heavily in research to create a uniquely wide-band UHF antenna with minimum 70MHz bandwidth that can replace expensive externally mounted antenna solutions. The wide-band compared to other narrow-band 20MHz antennas delivers more stable performance in a range of diverse on-glass environments with more resistance to detuning. All low frequency UHF antennas need to be tuned to suit their mounting conditions. For this reason this antenna is tuned to be mounted on glass. (i.e. excluding plastic or metal mounting), so is ideal for vehicles or building windows.

The standard cable is the RG174.

Cable length and connector type are fully customizable

The antenna can be customized for other low frequency bands for a minimum order quantity. Please contact your local sales office. For mounting applications on plastic please use ISA.06. For mounting directly on metal please use our FW series whip antennas.

2. Specification

ISM				
Frequency	410MHz	433MHz	450MHz	470MHz
Peak Gain *(dBi)	0.5	1.5	0.8	0
Average Gain *(dB)	-5.0	-4.3	-5.0	-5.0
Efficiency *(%)	30	35	30	30
Return Loss * (dB)	-10.0	<-15.0	-10.0	-8.0
Polarization	Linear			
Impedance	50Ω			
MECHANICAL				
Antenna Dimensions	239*42*10.5mm			
Cable	3m RG174 standard, customizable cable length			
Connector	SMA (M) standard, fully customizable			
Casing	TPR			
Waterproof	Outside Casing - IP65 Internal PCB Antenna - IP67			
ENVIRONMENTAL				
Operation Temperature	-40°C ~ +85°C			
Storage Temperature	-40°C ~ +85°C			

* all measurements were conducted with 3m RG174 cable

3. Antenna Characteristics

3.1 Return Loss

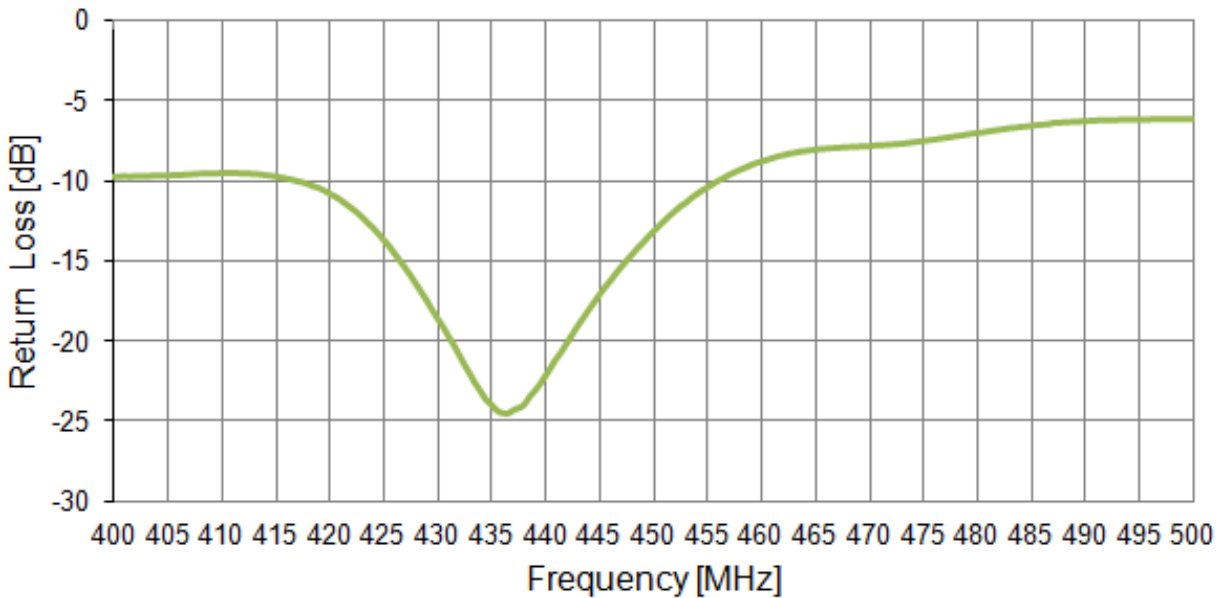

Figure 1. Return loss of the ISA.01 Antenna.

3.2 VSWR

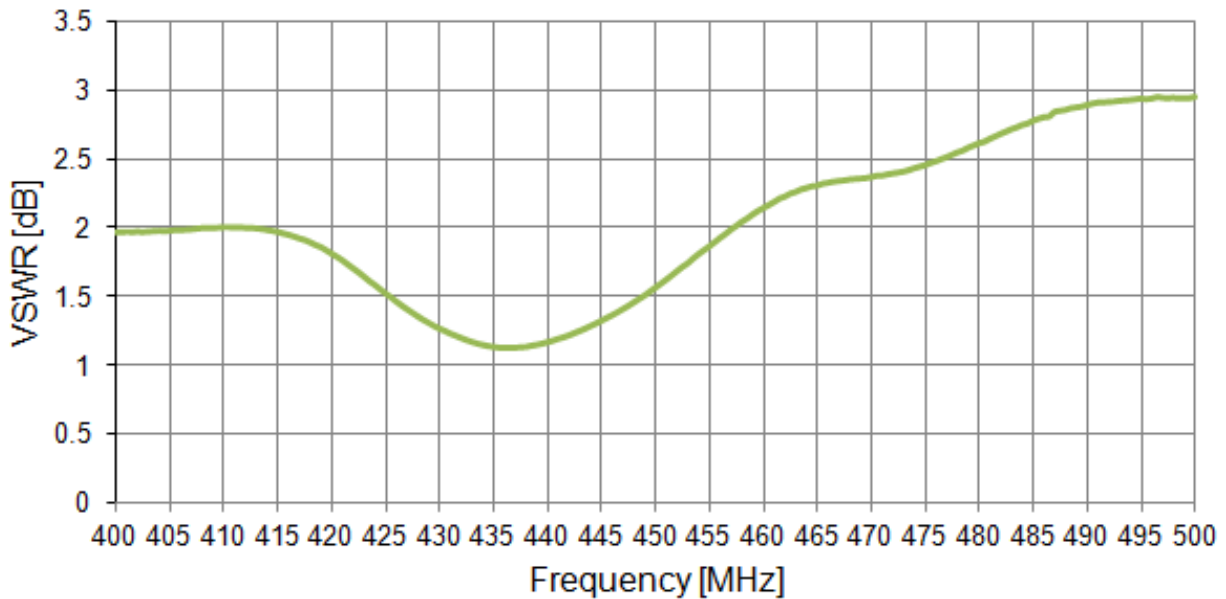

Figure 2. VSWR of the ISA.01 Antenna.

3.3 Efficiency

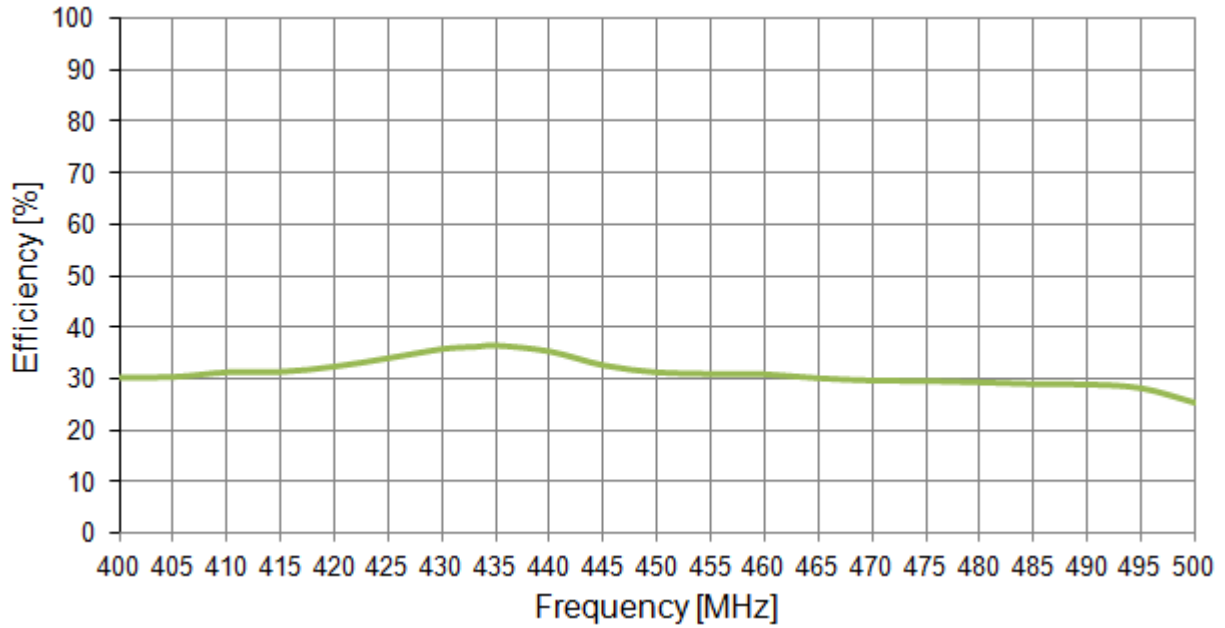

Figure 3. Efficiency of the ISA.01 antenna.

3.4 Peak Gain

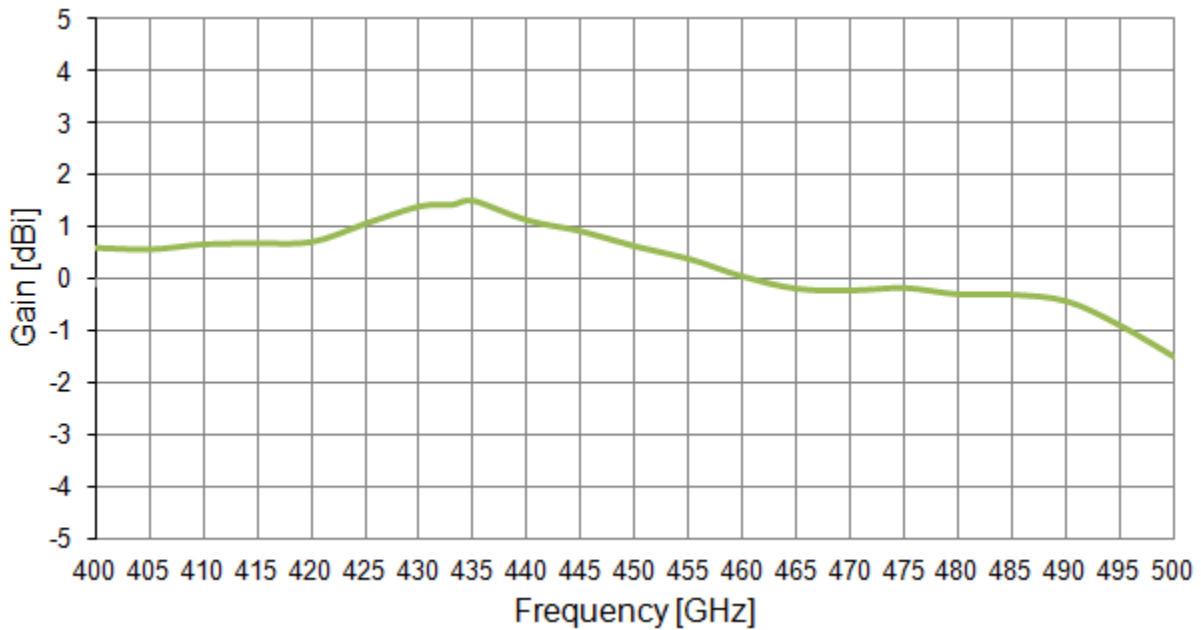

Figure 4. Peak Gain of the ISA.01 Antenna.

3.5 Average Gain

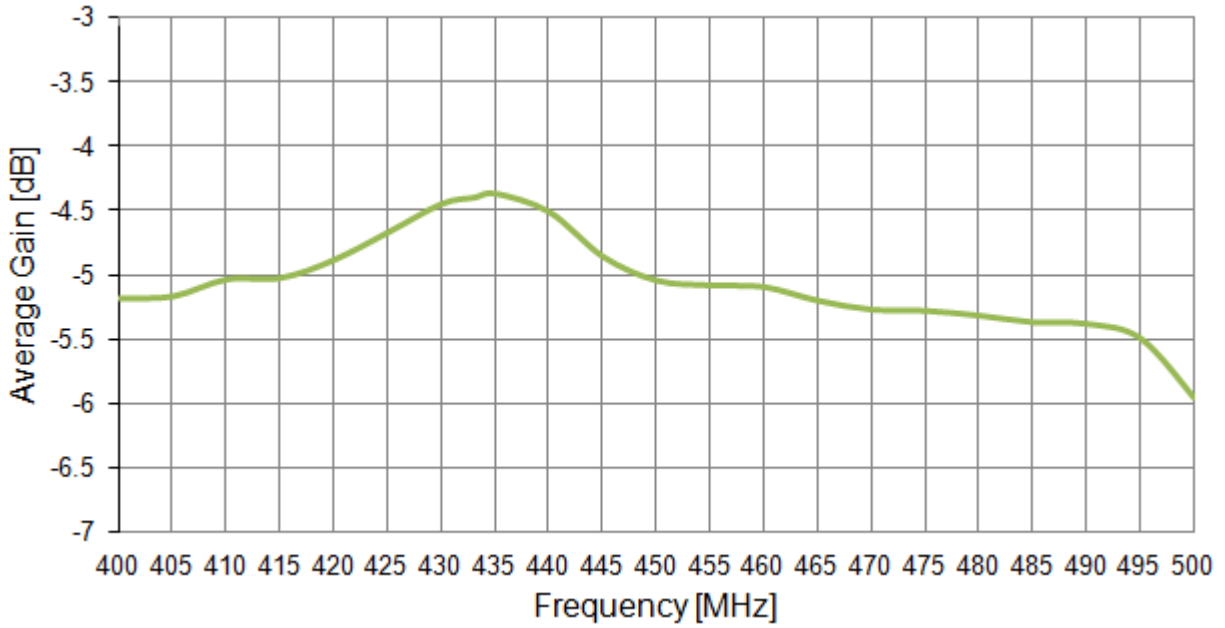

Figure 5. Average Gain of the ISA.01 Antenna.

4. 3D Radiation pattern

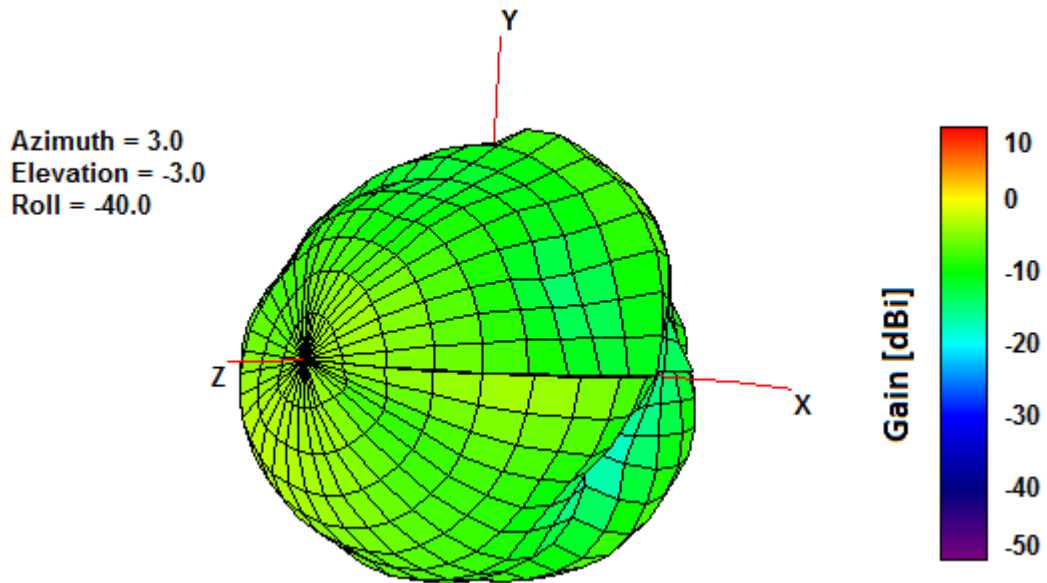

Figure 6. 3D Radiation Pattern at 433 MHz of the ISA.01 Antenna.



TAOGLAS®

5. 2D Radiation patterns

5.1 XY Plane Radiation

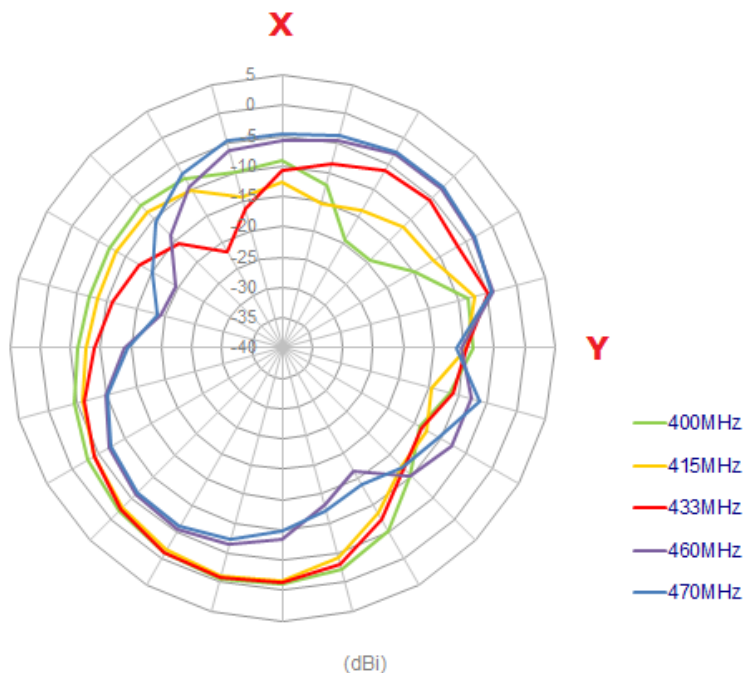

5.2 XZ Plane Radiation

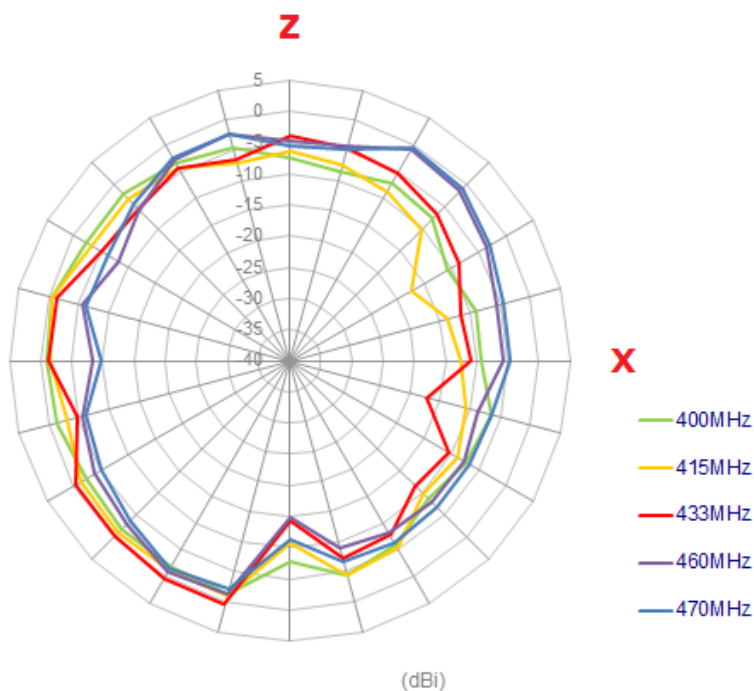

5.3 YZ Plane Radiation

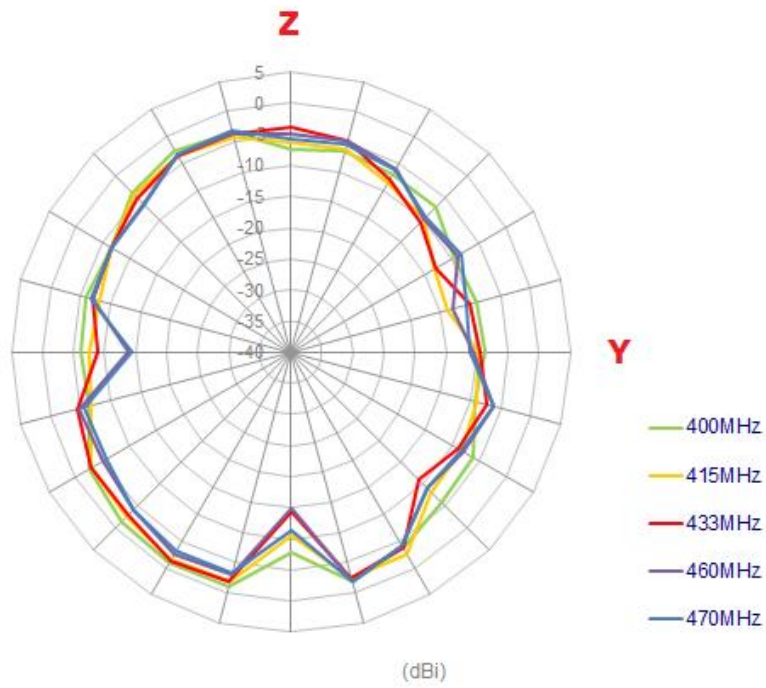
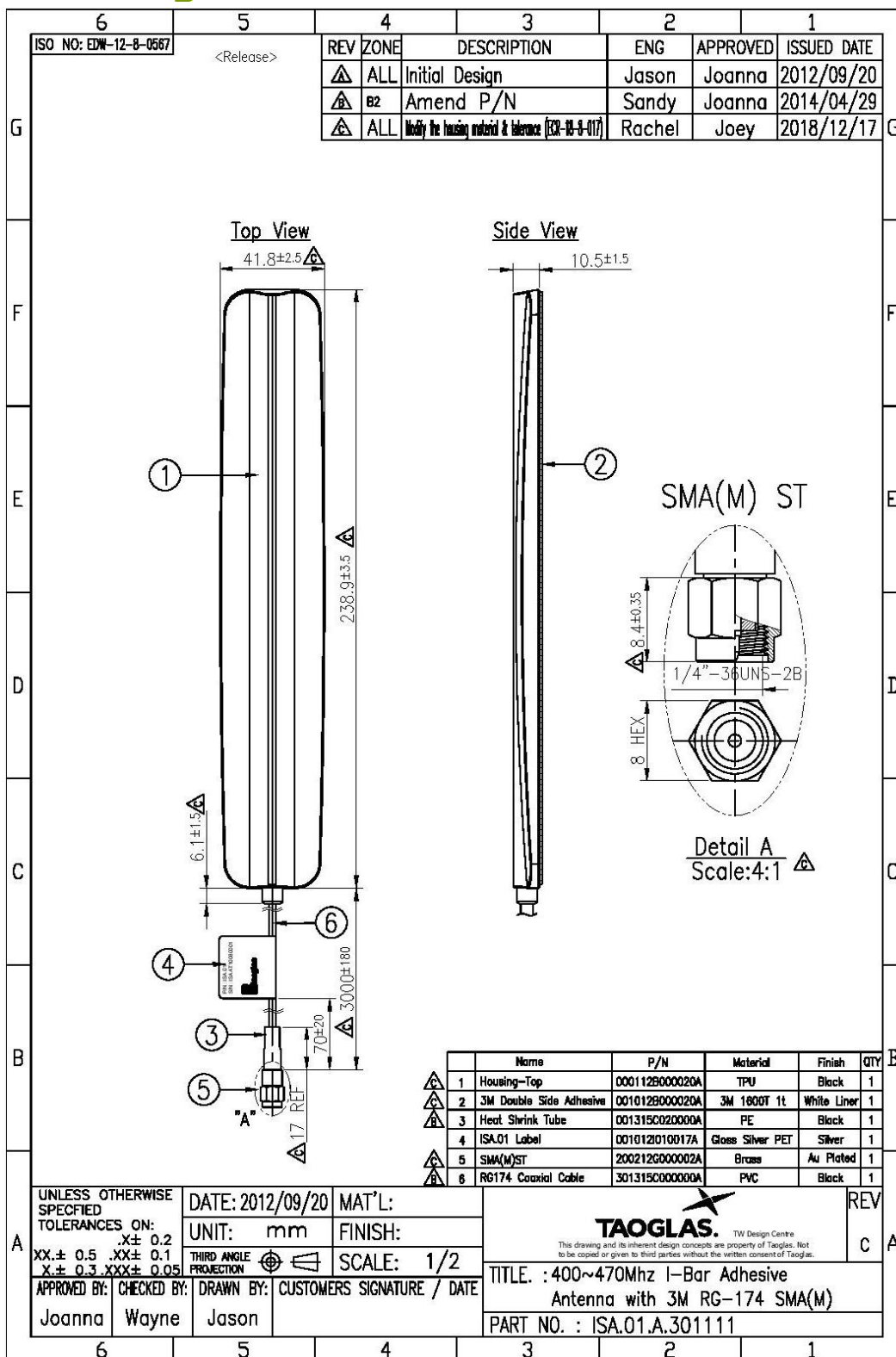

Figure 7. 2D Radiation Pattern of the ISA.01 Antenna.



6. Drawing





Taoglas makes no warranties based on the accuracy or completeness of the contents of this document and reserves the right to make changes to specifications and product descriptions at any time without notice. Taoglas reserves all rights to this document and the information contained herein.

Reproduction, use or disclosure to third parties without express permission is strictly prohibited.

Copyright © Taoglas Ltd.

X-ON Electronics

Largest Supplier of Electrical and Electronic Components

Click to view similar products for [Antennas](#) category:

Click to view products by [Taoglas](#) manufacturer:

Other Similar products are found below :

[GAN30084EU](#) [930-033-R](#) [GW17.07.0250E](#) [1513563-1](#) [EXE902SM](#) [APAMPG-117](#) [MAF94383](#) [W3908B0100](#) [W6102B0100](#) [YE572113-30RSMM](#) [108-00014-50](#) [66089-2406](#) [SPDA17RP918](#) [A09-F8NF-M](#) [A09-F5NF-M](#) [RGFRA1903041A1T](#) [W3593B0100](#) [W3921B0100](#) [SIMNA-868](#) [SIMNA-915](#) [SIMNA-433](#) [W1044](#) [W1049B090](#) [A75-001](#) [WTL2449CQ1-FRSMM](#) [CPL9C](#) [EXB148BN](#) [0600-00060](#) [TRA9020S3PBN-001](#) [GD5W-28P-NF](#) [MA9-7N](#) [GD53-25](#) [GD5W-21P-NF](#) [C37](#) [MAF94051](#) [MA9-5N](#) [EXD420PL](#) [B1322NR](#) [QWFTB120](#) [MAF94271](#) [MAF94300](#) [GPSMB301](#) [FG4403](#) [AO-AGSM-OM54](#) [5200232](#) [MIKROE-2349](#) [WCM.01.0111](#) [MIKROE-2393](#) [MIKROE-2352](#) [MIKROE-2350](#)