

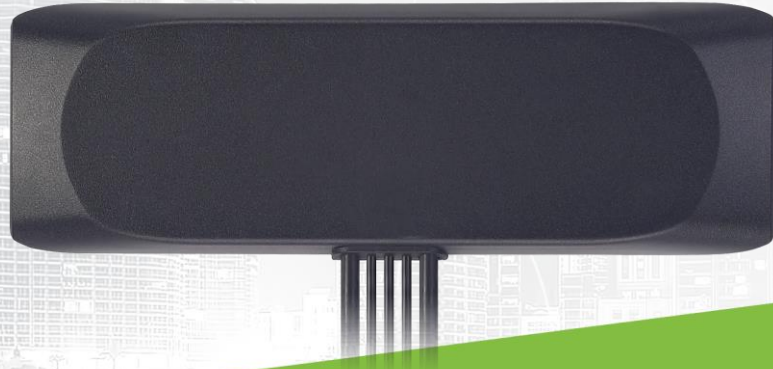

TAOGLAS®



Datasheet

5 in 1 Adhesive Mount Antenna

Part No:
MA275.LBICG.002

Description:

5in1 Adhesive Mount Combination Antenna GNSS, 2* LTE MIMO & 2* Wi-Fi
MIMO 3m cable with SMA type connectors

Features:

Adhesive Mount Combination Antenna

2*LTE: 3m CFD-200, SMA(M) Connector

2*Wi-Fi: 3m CFD-200, RP-SMA(M) Connector

1*Active GNSS: 3m RG-174, SMA(M) Connector

IP67 Rated Enclosure

Dims: 205.1*68*12.5 mm

Custom Cables and Connectors Available

RoHS & Reach Compliant

1. Introduction	3
2. Specifications	4
3. Antenna Characteristics	7
4. 2D Radiation Patterns	16
5. 3D Radiation Patterns	24
6. Mechanical Drawing	28
7. Packaging	29
8. Application Note	30
<hr/>	
Changelog	39

Taoglas makes no warranties based on the accuracy or completeness of the contents of this document and reserves the right to make changes to specifications and product descriptions at any time without notice. Taoglas reserves all rights to this document and the information contained herein.

Reproduction, use or disclosure to third parties without express permission is strictly prohibited.

Copyright © Taoglas Ltd.



1. Introduction

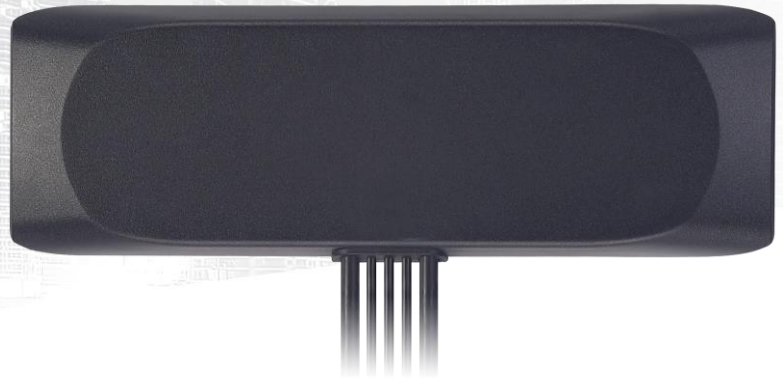

The Taoglas MA275 5in1 antenna is a combination of LTE, Wi-Fi and GNSS, IP67 waterproof external M2M antenna for use in telematics, transportation, and remote monitoring applications.

This unique antenna delivers powerful MIMO antenna technology for cellular LTE, Wi-Fi dual-band 2.4/5 GHz as well as GPS-GLONASS for next generation multiple wireless technology systems, such as vehicle telematics.

Potential uses are new fleet management and applications that demand high speed data uplink and downlink. High efficiency and high gain MIMO antennas are necessary to achieve the required signal to noise ratio and throughput required to solve these challenges. The GNSS antenna has been carefully designed to work equally well on both GPS/GALILEO and GLONASS bands, leading to higher location accuracy and stability of tracking in urban environments.

Cable length and connector types are customizable. Contact your regional Taoglas sales office for support.

2. Specifications

LTE MIMO 1&2 Antenna									
Frequency (MHz)	LTE700	GSM850	GSM900	DCS	PCS	UMTS1	LTE2600	LTE3500	
	698~803	824~894	880~960	1710~1880	1850~1990	1920~2170	2300~2690	3300~3500	
Efficiency (%)									
MIMO1	0.3M	41.29	48.36	65.64	62.11	56.32	48.15	70.92	72.17
	1M	39.11	46.19	62.72	56.67	51.37	44.38	64.68	64.30
	2M	36.50	42.29	57.20	50.50	45.47	38.89	56.22	54.24
	3M	33.81	39.31	53.14	44.90	40.00	34.39	48.94	46.58
	5M	31.32	36.54	49.36	39.92	35.19	30.42	42.60	40.01
MIMO2	0.3M	45.77	44.37	48.64	67.81	81.95	78.16	68.89	68.09
	1M	43.38	42.36	46.44	61.83	74.76	72.06	62.83	60.72
	2M	40.49	38.81	42.35	55.11	66.13	63.14	54.61	51.29
	3M	37.48	36.05	39.37	48.96	58.18	55.84	47.57	43.99
	5M	34.70	33.49	36.60	43.51	51.20	49.39	41.44	37.72
Average Gain (dB)									
MIMO1	0.3M	-2.83	-2.43	-0.98	-1.91	-1.91	-2.52	-0.70	-0.88
	1M	-3.13	-2.63	-1.18	-2.31	-2.31	-2.92	-1.10	-1.38
	2M	-3.43	-3.03	-1.58	-2.81	-2.81	-3.42	-1.70	-2.08
	3M	-3.73	-3.33	-1.98	-3.31	-3.31	-4.02	-2.30	-2.78
	5M	-4.03	-3.63	-2.38	-3.81	-3.81	-4.62	-2.90	-3.48
MIMO2	0.3M	-3.39	-3.53	-3.13	-1.69	-0.86	-1.07	-1.62	-1.67
	1M	-3.63	-3.73	-3.33	-2.09	-1.26	-1.42	-2.02	-2.17
	2M	-3.93	-4.11	-3.73	-2.59	-1.80	-2.00	-2.63	-2.90
	3M	-4.26	-4.43	-4.05	-3.10	-2.35	-2.53	-3.23	-3.57
	5M	-4.60	-4.75	-4.36	-3.61	-2.91	-3.06	-3.83	-4.23
Peak Gain (dBi)									
MIMO1	0.3M	2.36	0.91	3.19	4.28	4.28	2.00	4.77	3.66
	1M	2.06	0.71	2.99	3.88	3.88	1.62	4.37	3.16
	2M	1.76	0.31	2.59	3.38	3.38	1.08	3.77	2.46
	3M	1.46	0.01	2.19	2.88	2.88	0.52	3.17	1.76
	5M	1.16	-0.29	1.79	2.38	2.38	0.02	2.57	1.06
MIMO2	0.3M	1.76	1.39	1.96	3.14	3.65	3.65	3.57	4.28
	1M	1.46	1.19	1.76	2.74	3.25	3.25	3.17	3.78
	2M	1.16	0.79	1.36	2.24	2.69	2.69	2.57	3.08
	3M	0.86	0.49	0.96	1.69	2.15	2.15	1.97	2.38
	5M	0.56	0.19	0.56	1.19	1.65	1.65	1.37	1.68
Impedance					50 Ω				
Polarization					Linear				

Wi-Fi Antenna (2.4GHz/5.8GHz)			
Frequency (MHz)		2400~2500	4900~5850
Efficiency (%)			
MIMO1	0.3M	64.46	68.73
	1M	58.78	59.24
	2M	51.19	48.02
	3M	44.59	38.90
	5M	38.83	31.52
MIMO2	0.3M	73.89	69.93
	1M	67.40	60.21
	2M	58.70	48.79
	3M	51.13	39.50
	5M	44.53	31.98
Average Gain (dB)			
MIMO1	0.3M	-1.91	-1.63
	1M	-2.31	-2.27
	2M	-2.91	-3.19
	3M	-3.51	-4.10
	5M	-4.11	-5.01
MIMO2	0.3M	-1.31	-1.55
	1M	-1.71	-2.20
	2M	-2.31	-3.12
	3M	-2.91	-4.03
	5M	-3.51	-4.95
Peak Gain (dBi)			
MIMO1	0.3M	2.07	3.98
	1M	1.67	3.38
	2M	1.07	2.48
	3M	0.47	1.61
	5M	-0.13	0.81
MIMO2	0.3M	4.52	6.98
	1M	4.12	6.38
	2M	3.52	5.48
	3M	2.92	4.58
	5M	2.32	3.68
Impedance	50 Ω		
Return loss	< -6 dB		
Polarization	Linear		

GNSS Electrical

Frequency	GPS L1: 1575.42 MHz \pm 1.023 MHz GLONASS L1: 1602 MHz \pm 1.023 MHz		
Bandwidth - Return Loss <-10 dB	6 MHz min		
Return loss (GPS L1 GLONASS L1)	< -10 dB		
Passive Gain at Zenith (GPS L1 and GLONASS L1)	+1.0 dBic typ.		
Polarization	RHCP		
Impedance	50 Ω		
LNA Out-band Attenuation	fo = 1575.42MHz fo \pm 30 MHz 5dB Min. fo \pm 50 MHz 20dB Min. fo \pm 100 MHz 25dB Min.		
Input Voltage	Min:1.8V	Typ. 3.0V	Max: 5.5V
Total Gain @ Zenith	23dBic	31dBic	34dBic
Current Consumption	8 mA	15 mA	28 mA
Noise Figure	2.5 dB	2.3 dB	2.6 dB

Mechanical

Dimensions	205.1*68*12.5 mm		
Cable	LTE MIMO1/ MIMO2: 3000mm CFD-200 WI-FI MIMO1/ MIMO2: 3000mm CFD-200 GNSS: 3000mm RG-174		
Connector	LTE: SMA(M) WI-FI: RP-SMA(M) GNSS: SMA(M)		
Casing	PC+ABS		
Adhesive	3M 9448HK + CR4305		
Sealant	Rubber Stopper		
Weight	650g		

Environmental

Protection	IP67		
Cable Pull	8 Kgf		
Temperature Range	-40°C to +85°C		
Temperature Cycle	30 cycles -40°C to +85°C, 1 cycle 8 hours		
Humidity	Non-condensing 65°C 95% RH		
Vibration	Frequency: 10~1000Hz, 3 axis, 8 hours / axis		

3. Antenna Characteristics

3.1 Return Loss – LTE MIMO 1 & 2

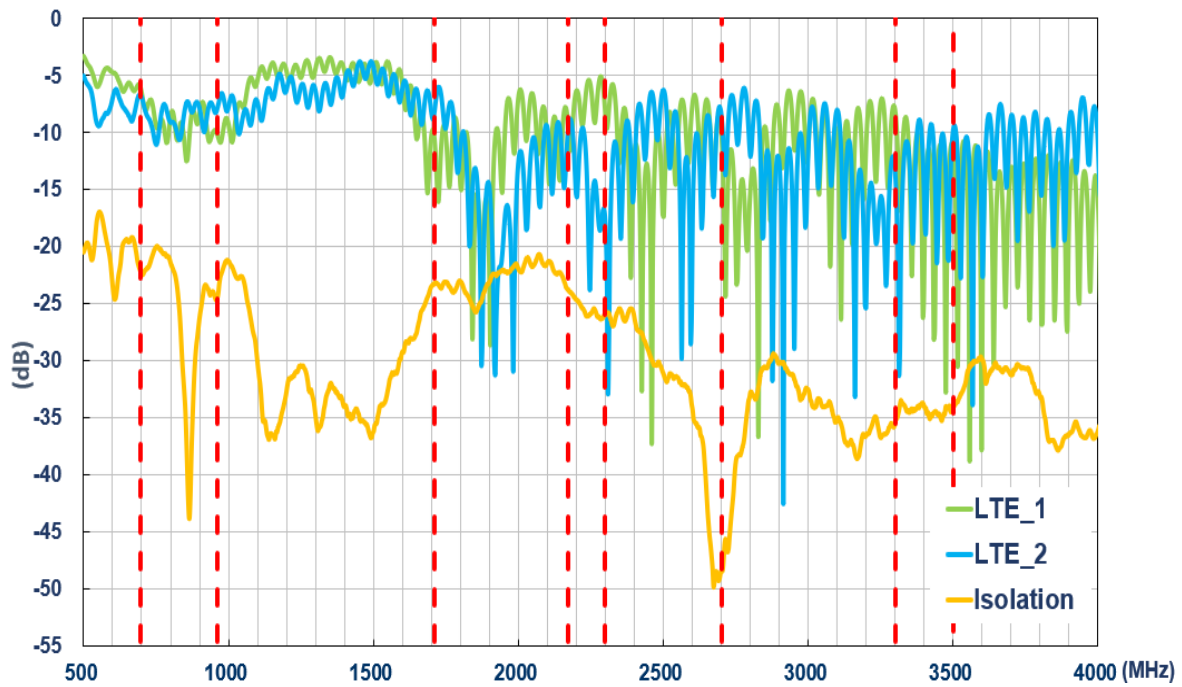

3.2 Efficiency – LTE MIMO 1 & 2

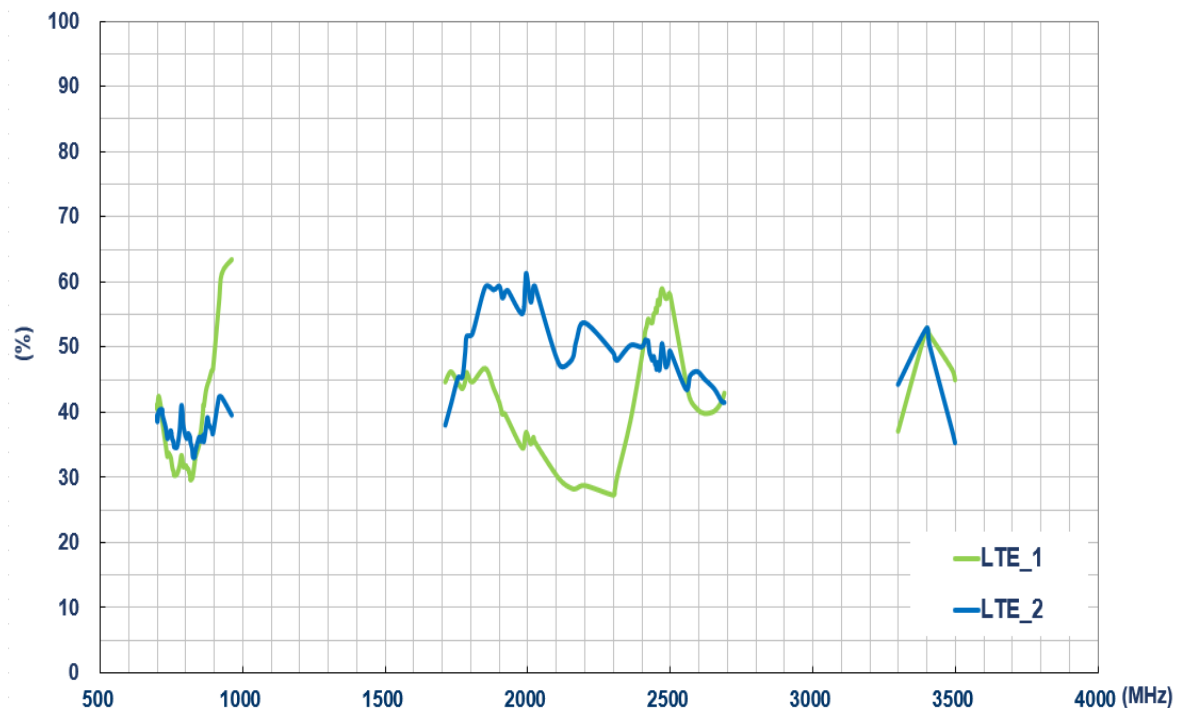

3.3 Average Gain - LTE MIMO 1 & 2

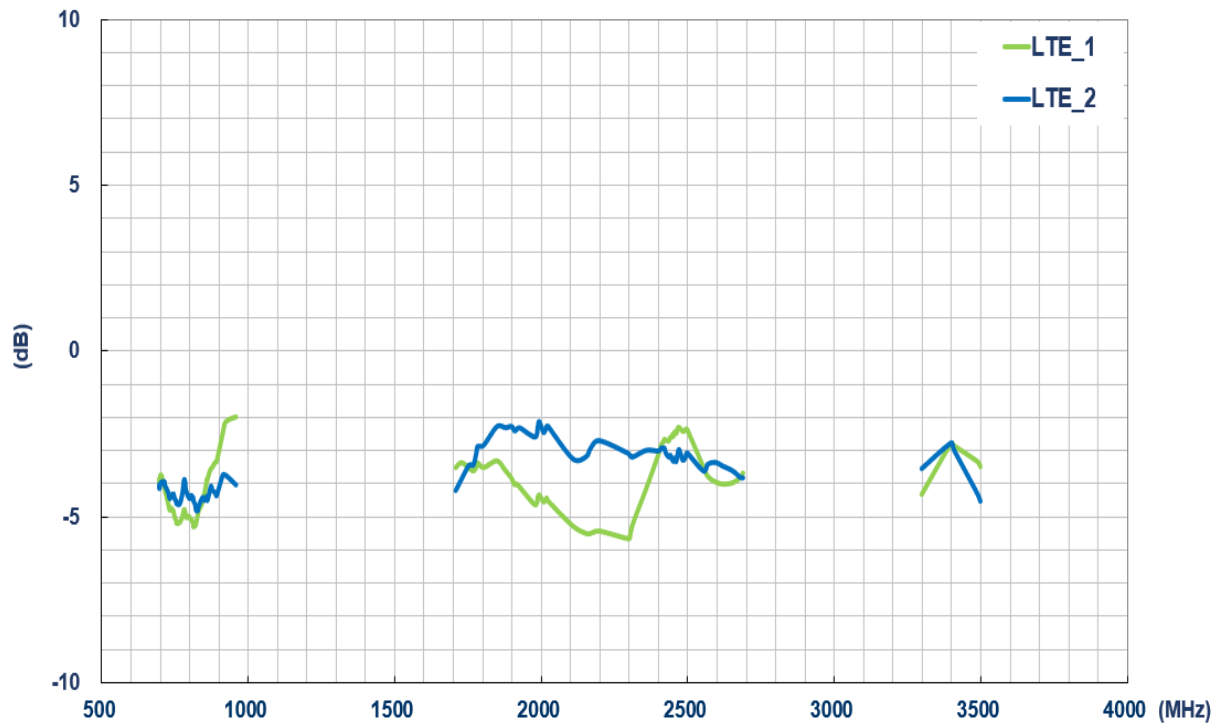

3.4 Peak Gain – LTE MIMO 1 & 2

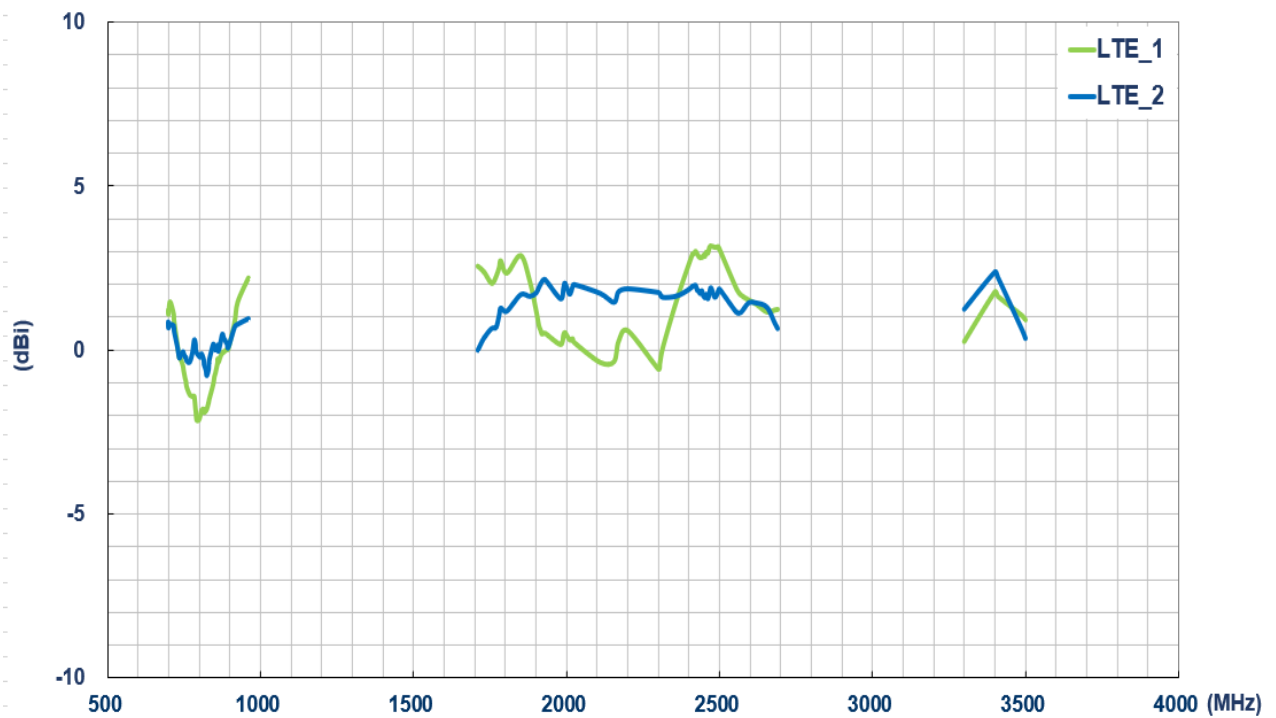

3.5 ECC – LTE MIMO 1 & 2

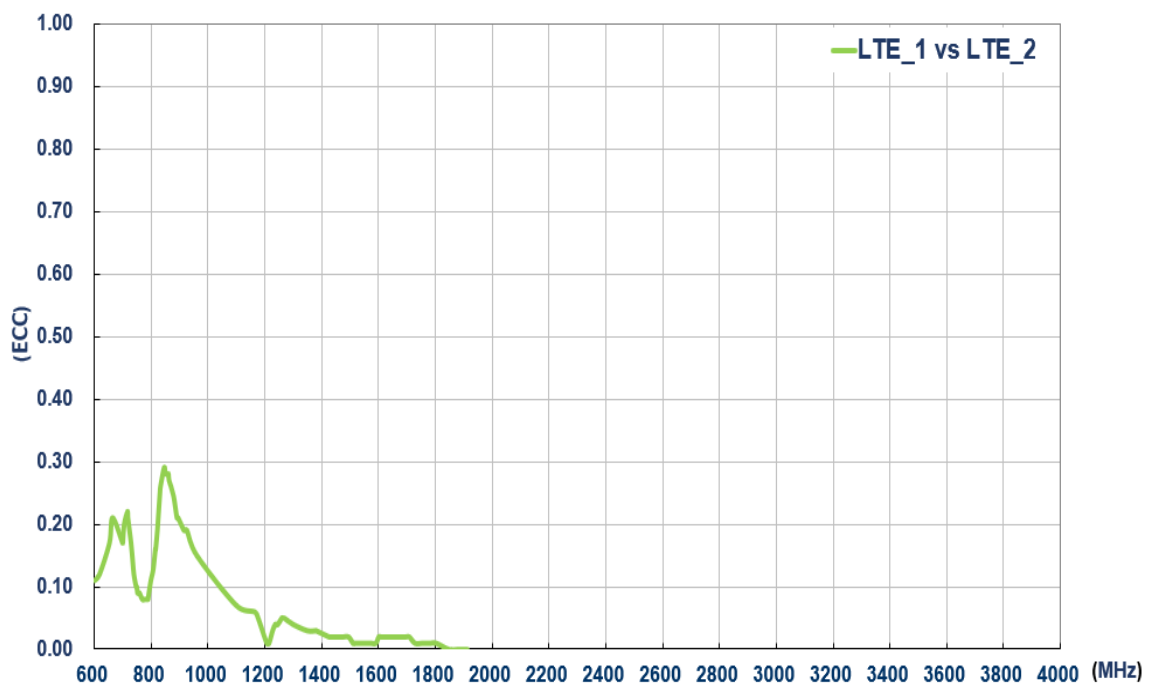

3.6 Return Loss – Wi-Fi MIMO 1 & 2

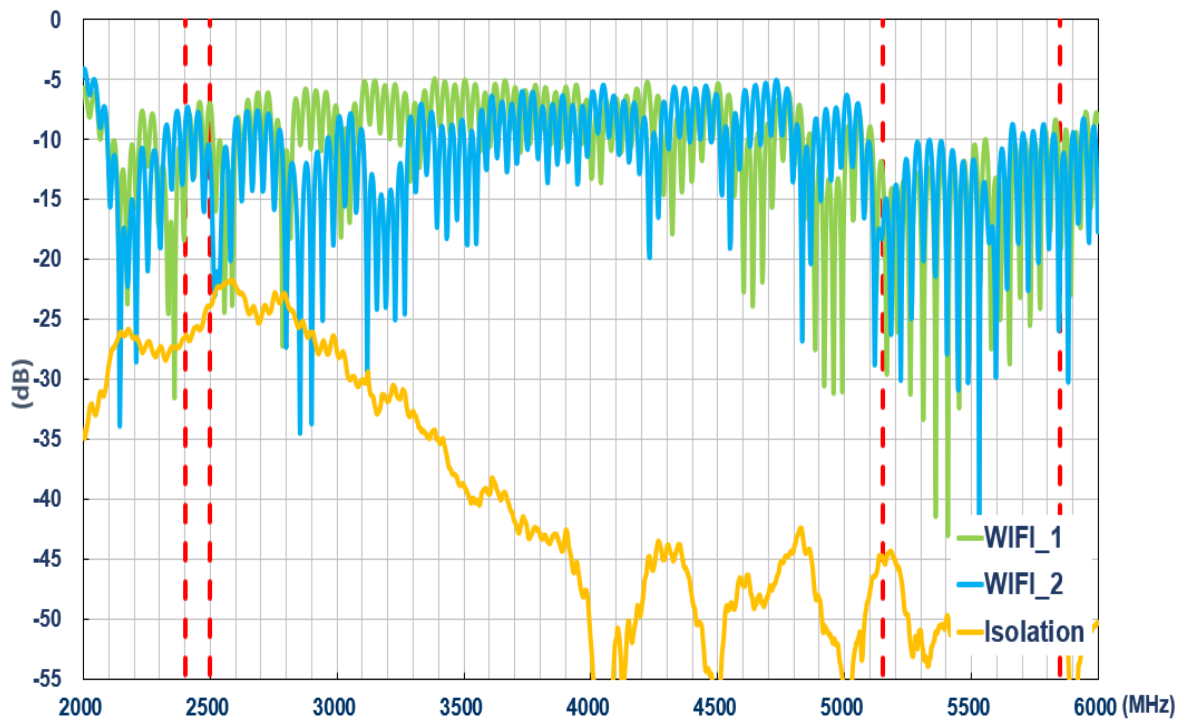

3.7 Efficiency – Wi-Fi MIMO 1 & 2

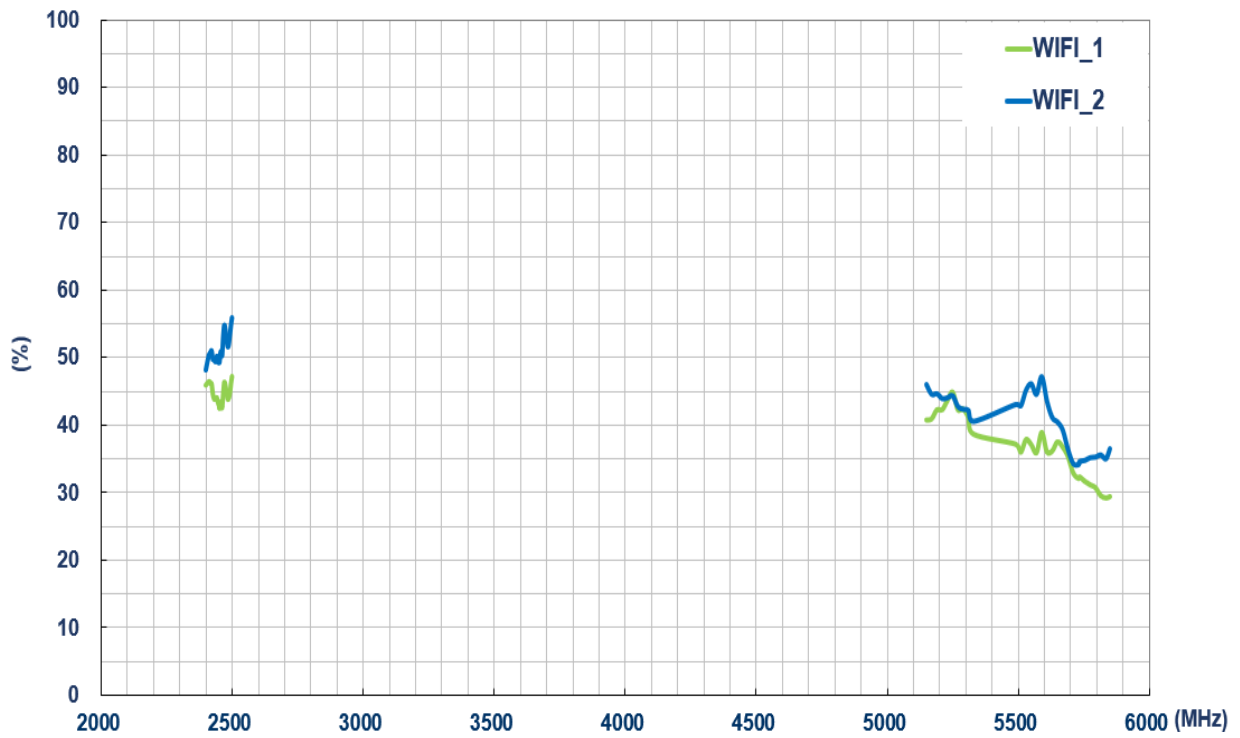

3.8 Average Gain – Wi-Fi MIMO 1 & 2

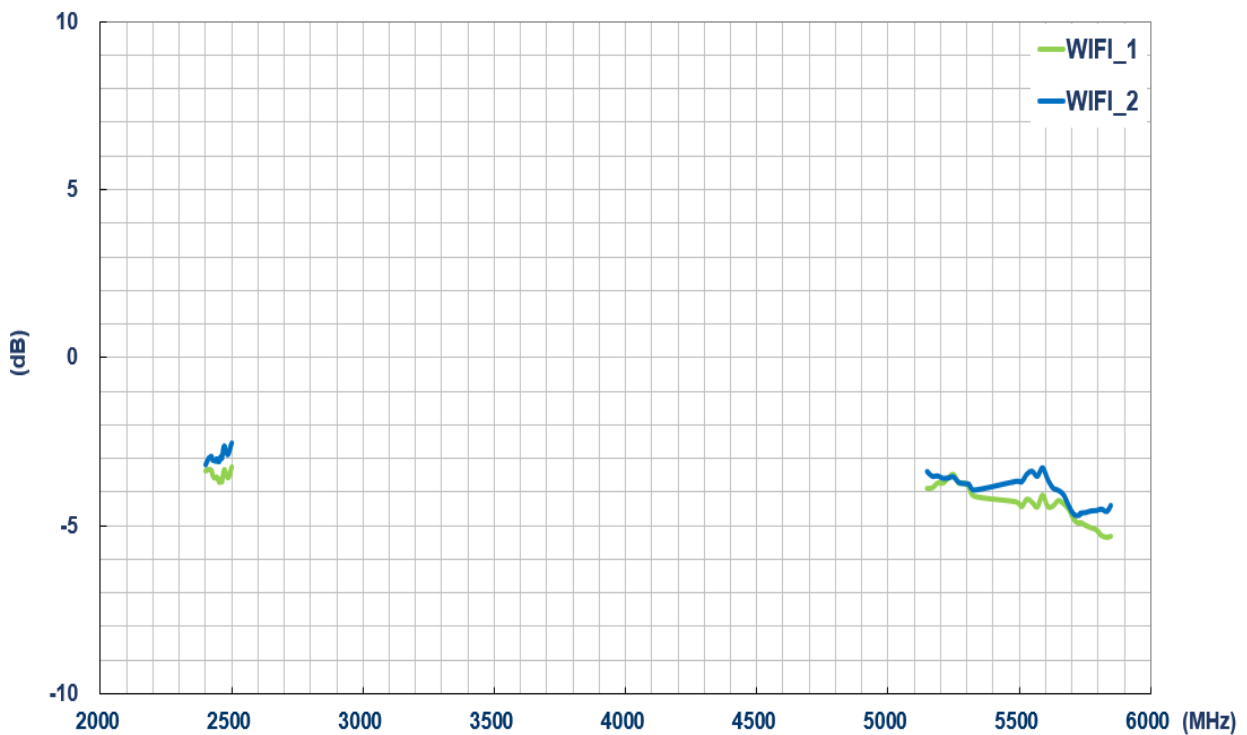

3.9 Peak Gain – Wi-Fi MIMO 1 & 2

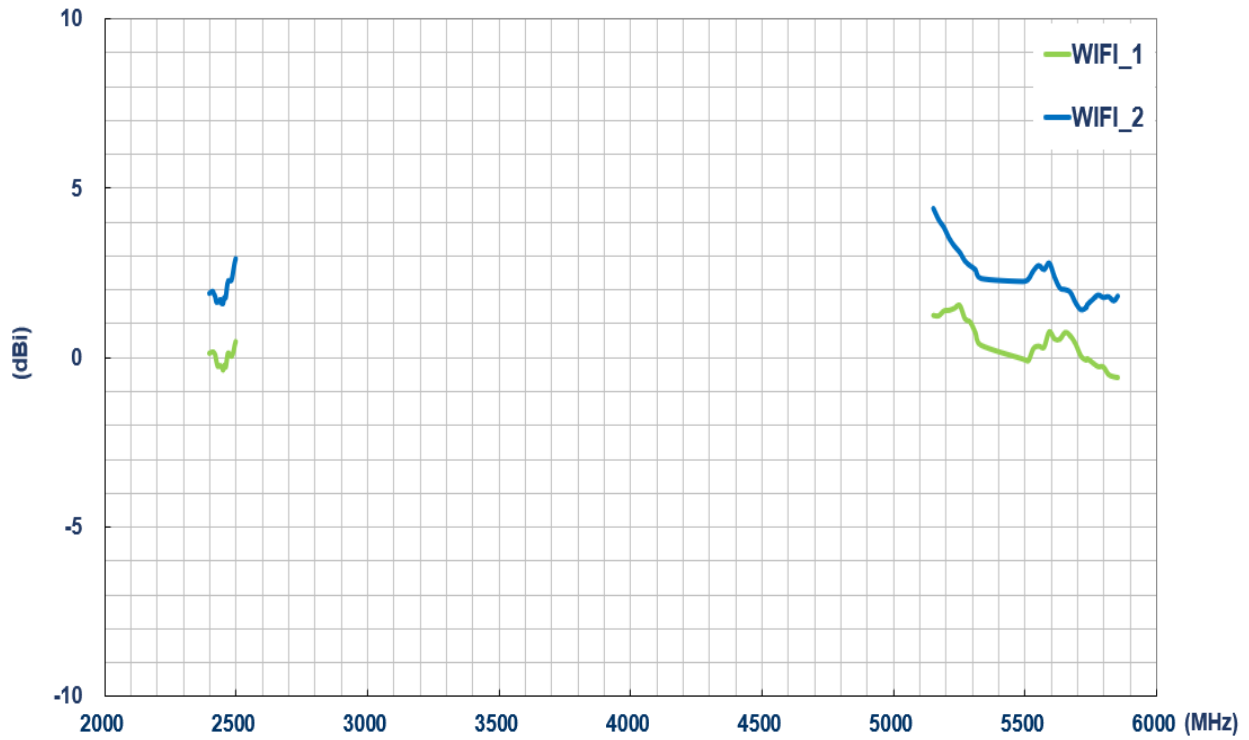

3.10 ECC – Wi-Fi MIMO 1 & 2

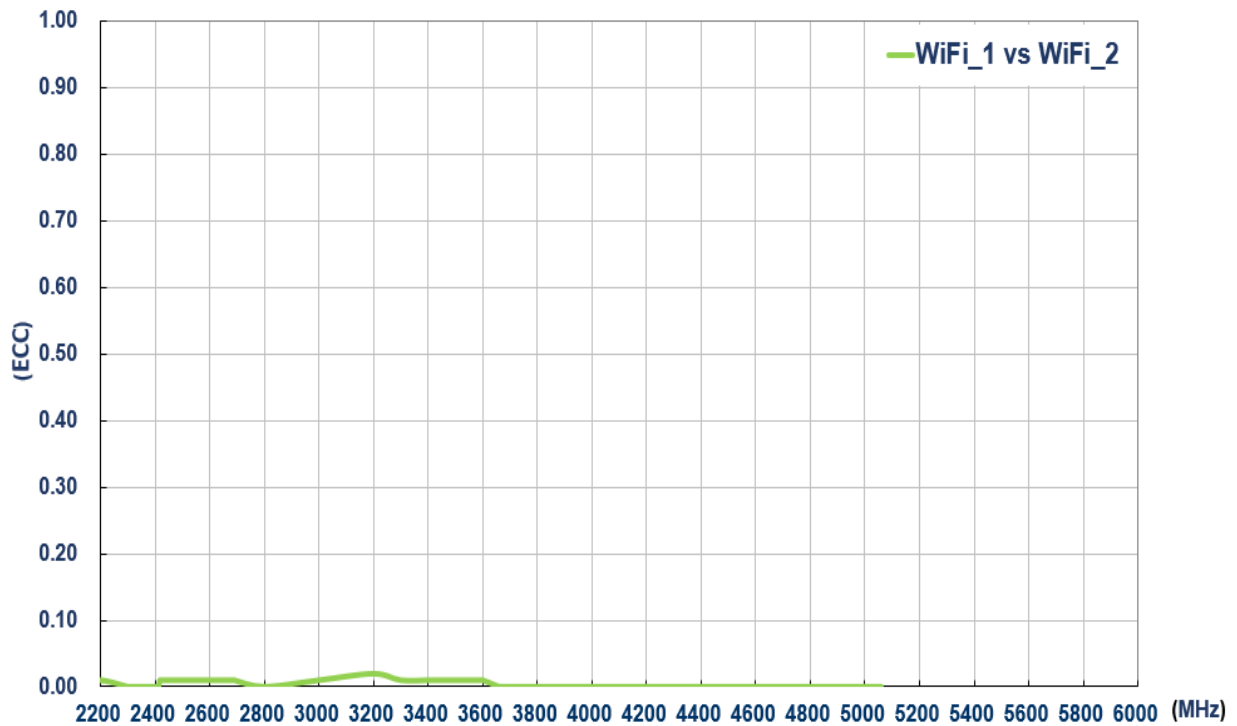

3.11 GNSS Antenna – Block Diagram

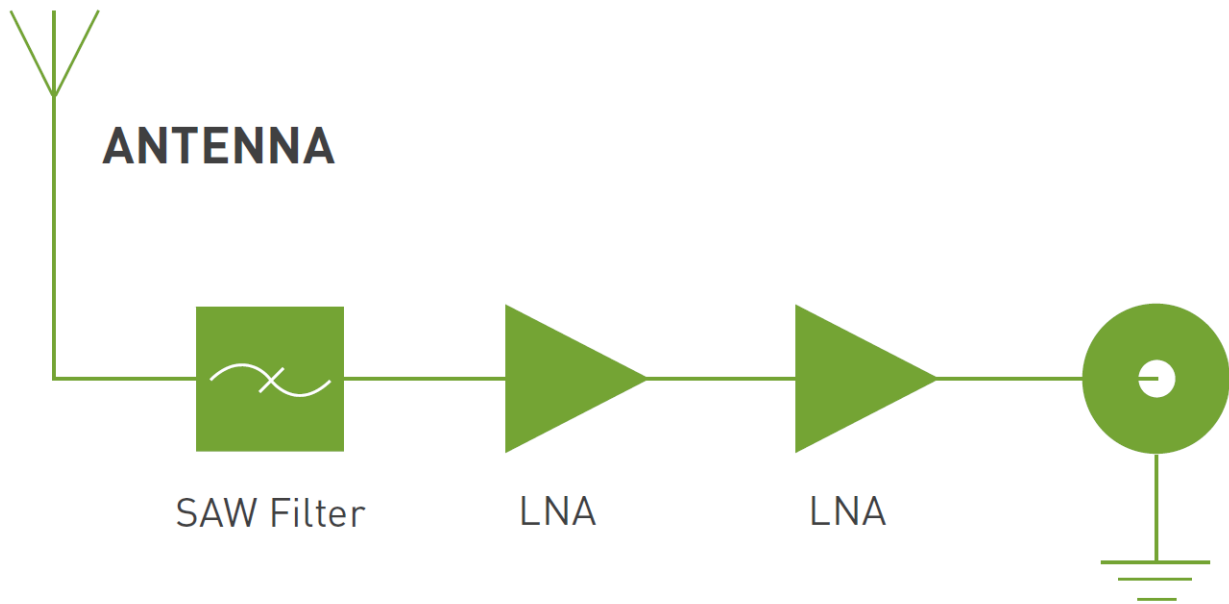

3.12 Return Loss – GNSS Antenna

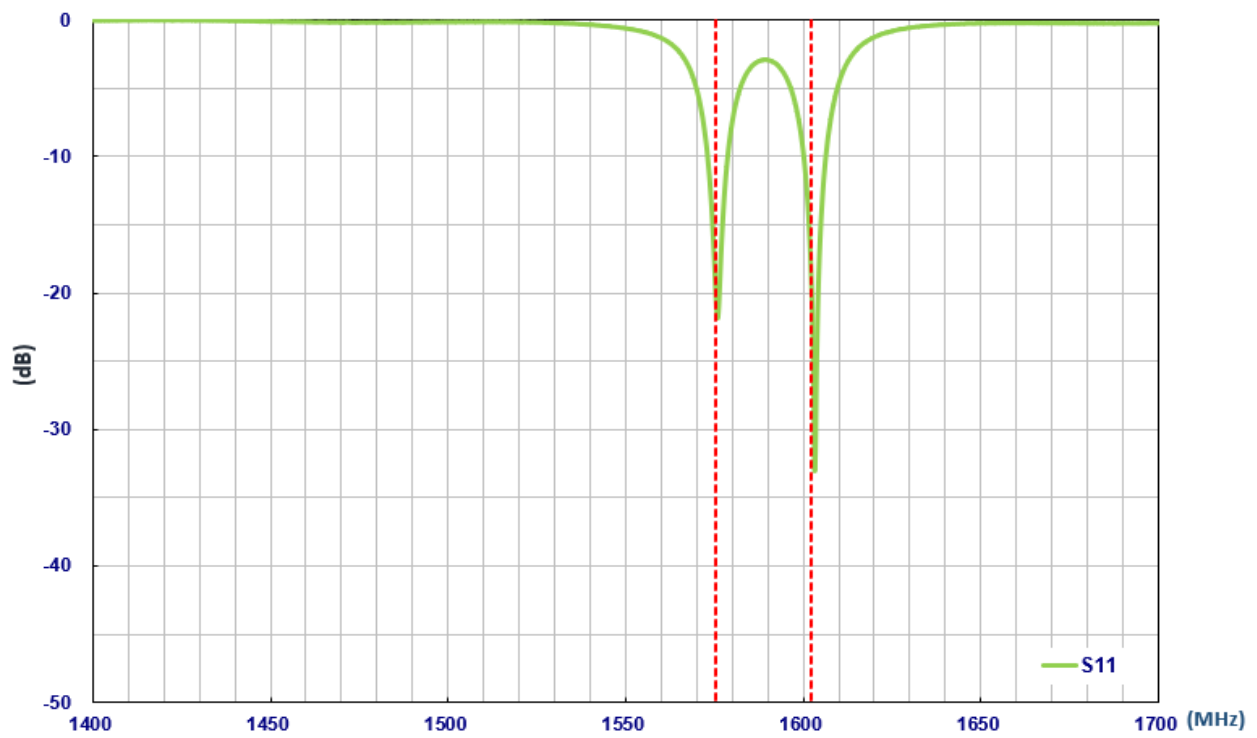

3.13 Efficiency – GNSS Antenna

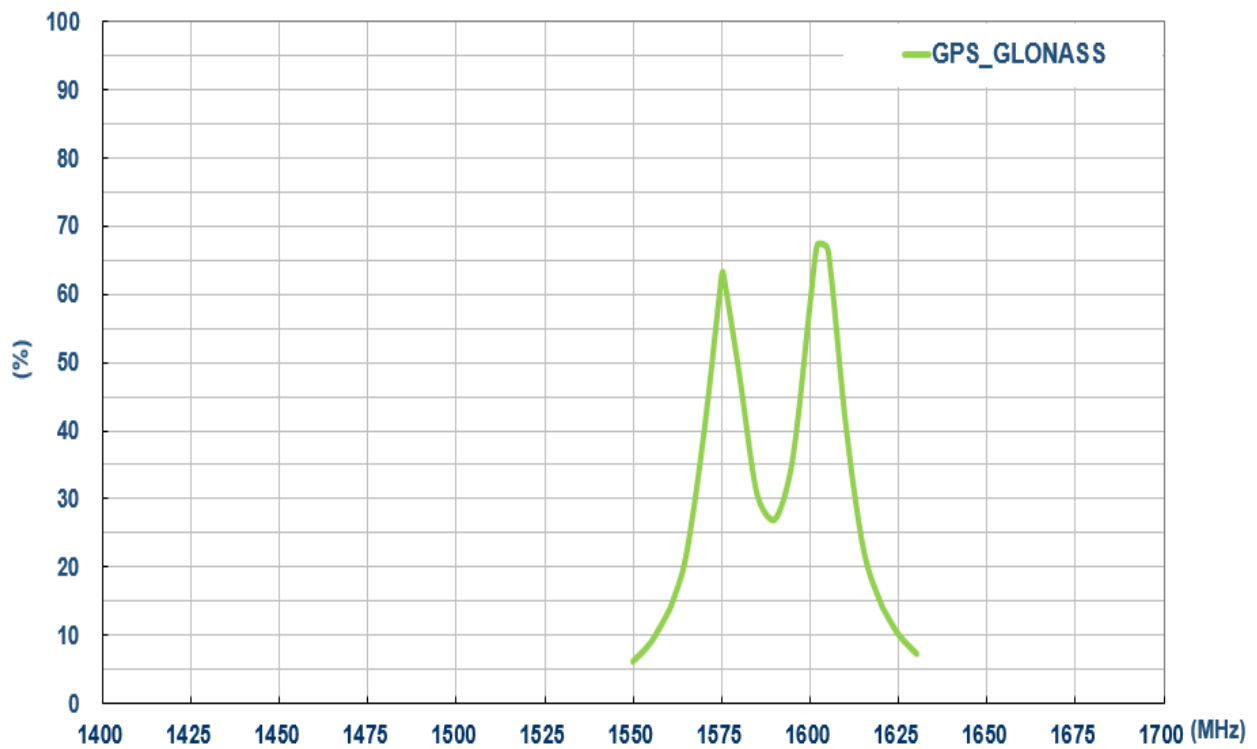

3.14 Average Gain – GNSS Antenna

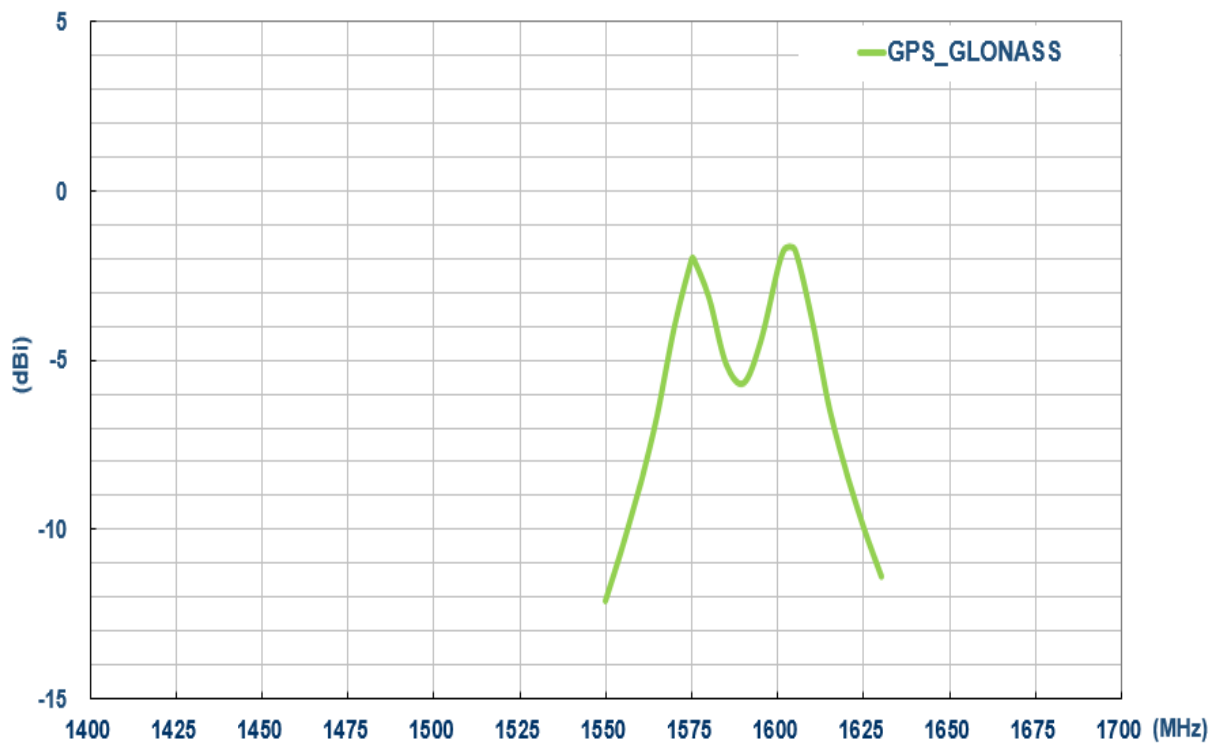

3.15 Peak Gain – GNSS Antenna

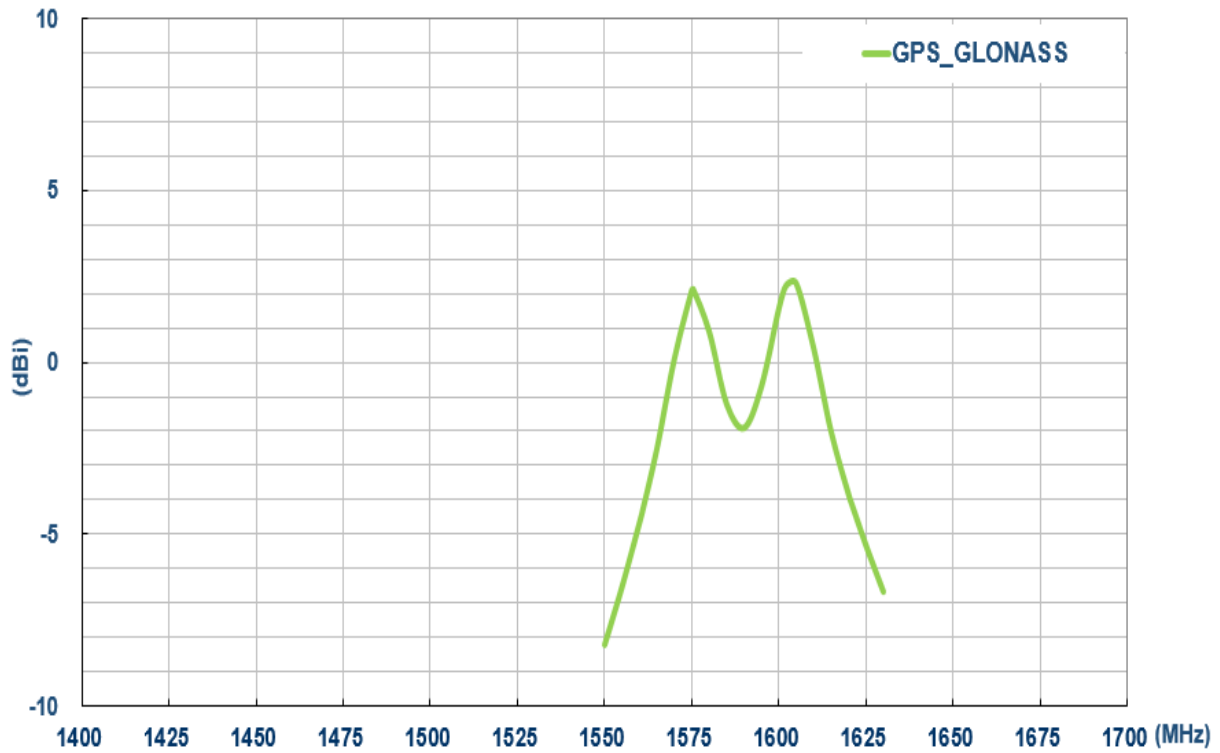

3.16 Axial Ratio – GNSS Antenna

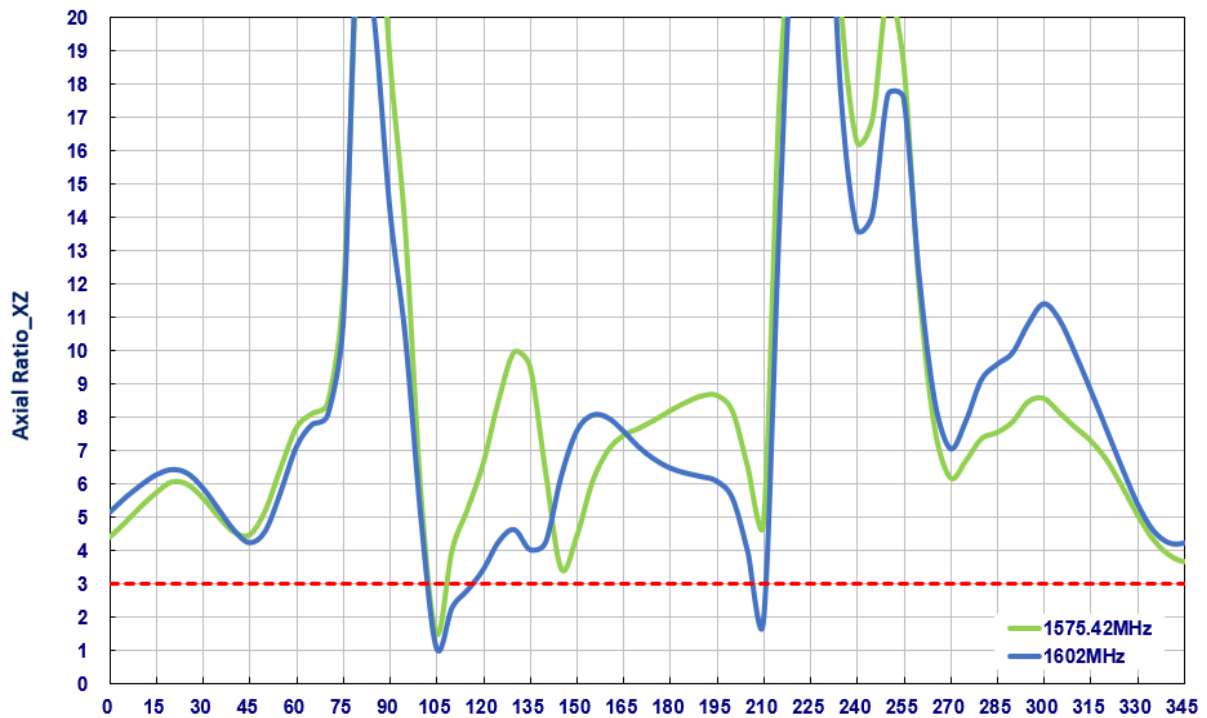

3.17 Active Measurements LNA Gain @ 3.0V – GNSS Antenna

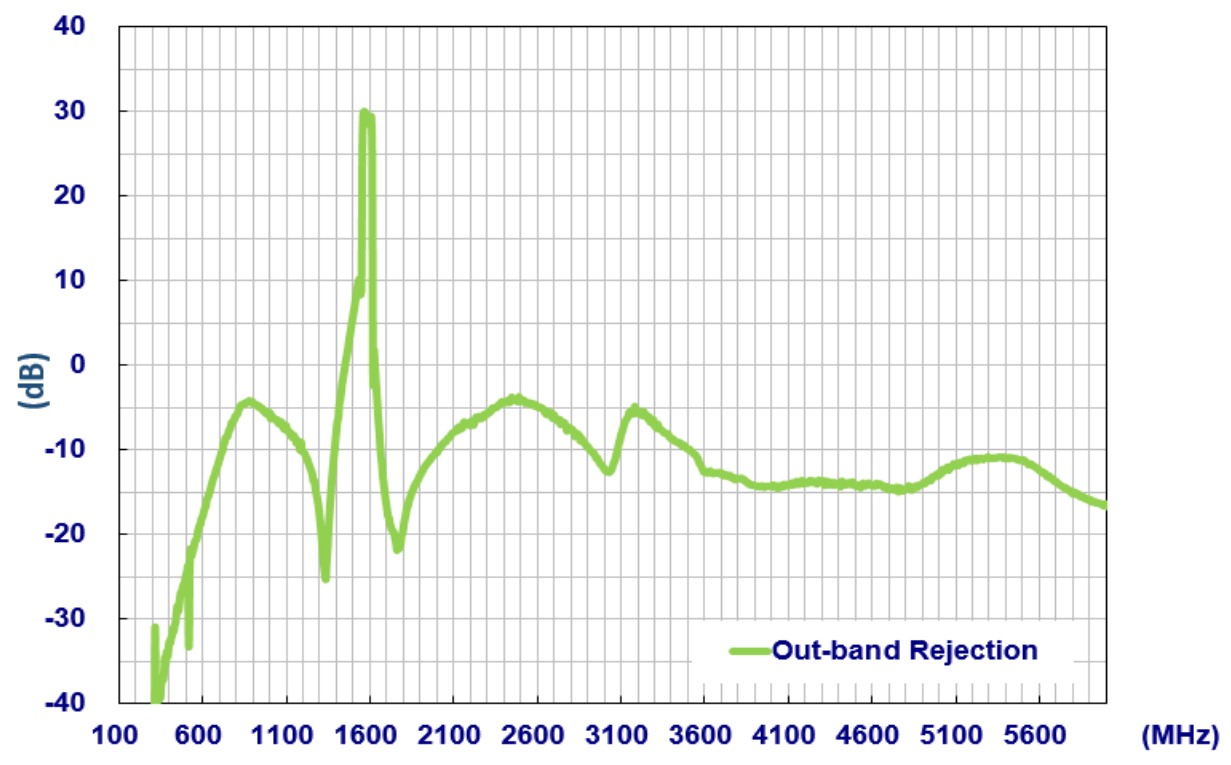

3.18 LNA Gain and Noise Figure @ 3.0V – GNSS Antenna

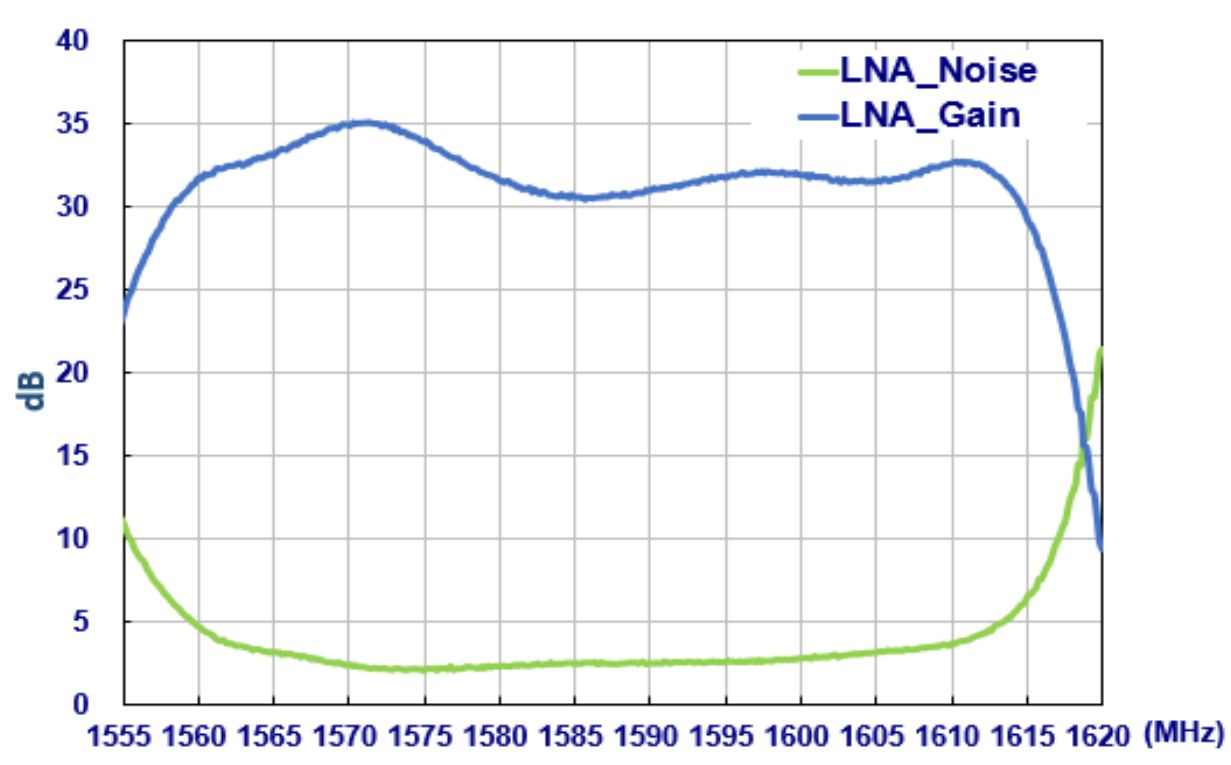

4. 2D Radiation Patterns

4.1 Test Setup



Free space

4.2 LTE MIMO 1

XY Plane

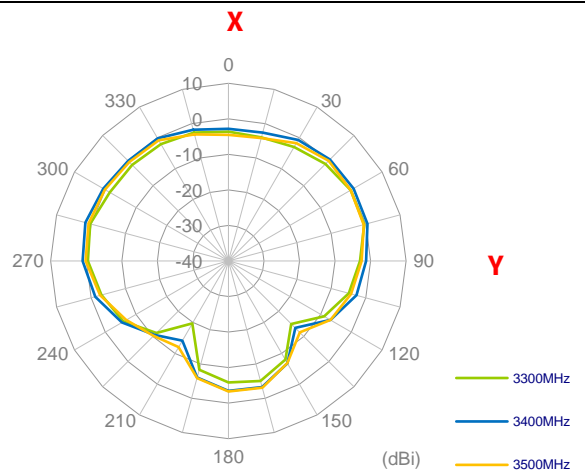
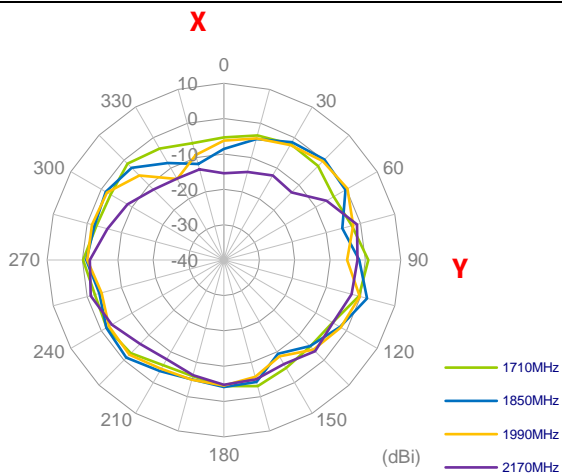
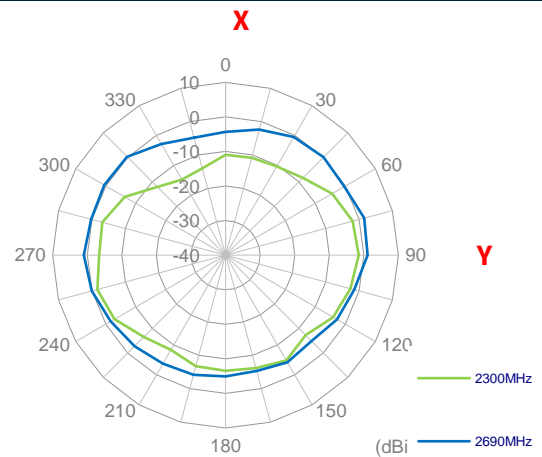
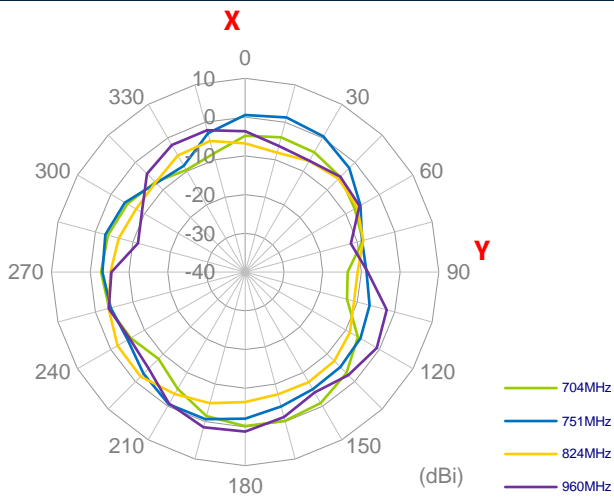

XZ Plane

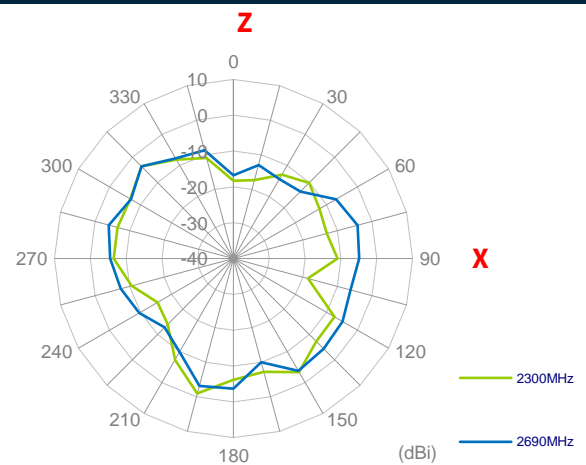
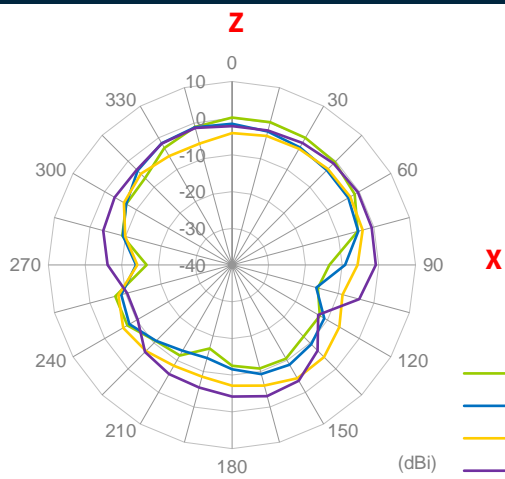

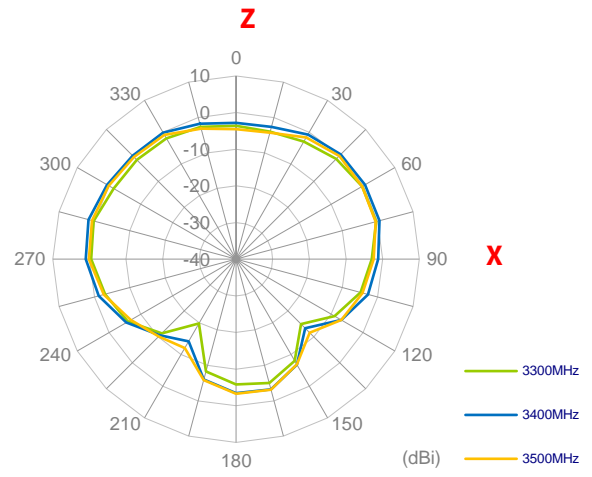
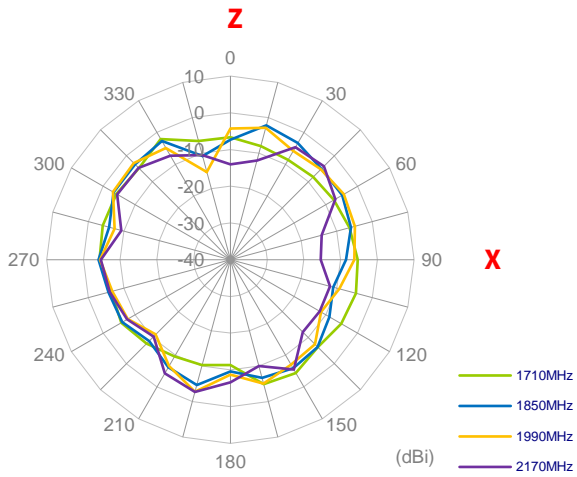

YZ Plane

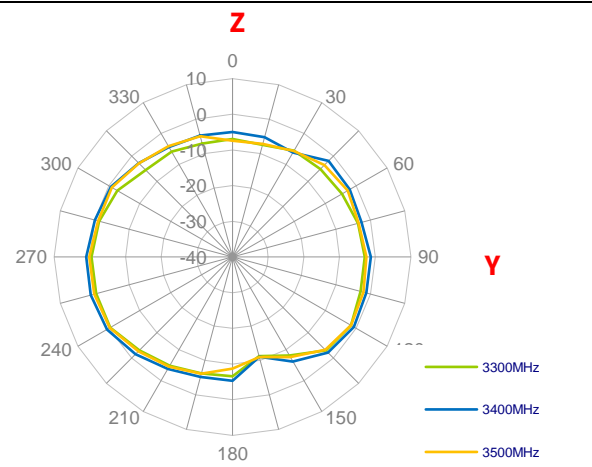
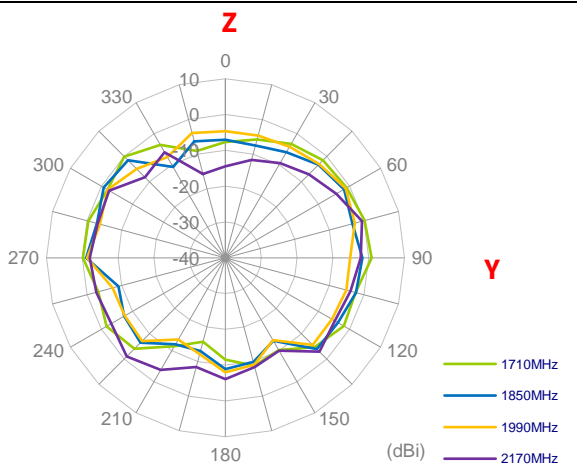
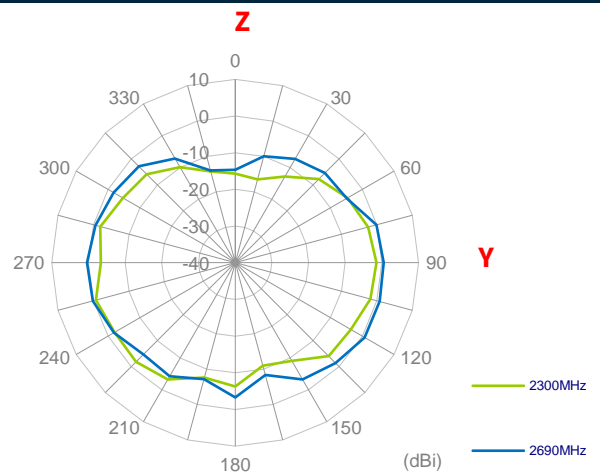
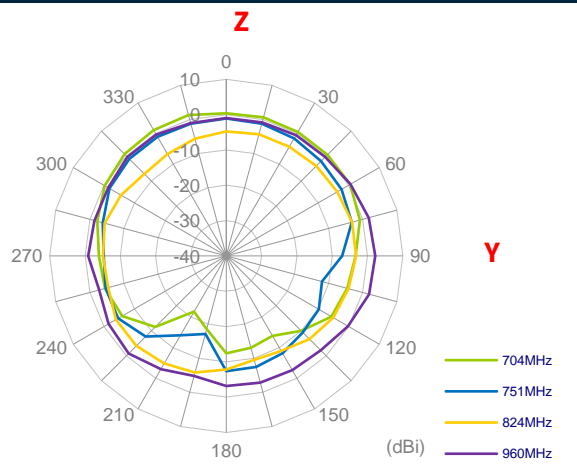

4.3 LTE MIMO 2

XY Plane

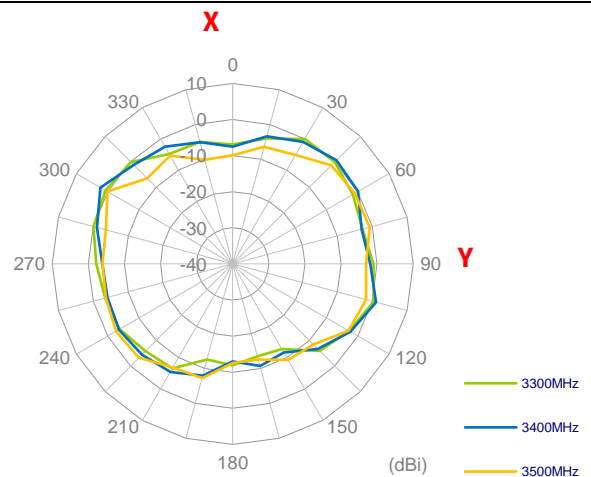
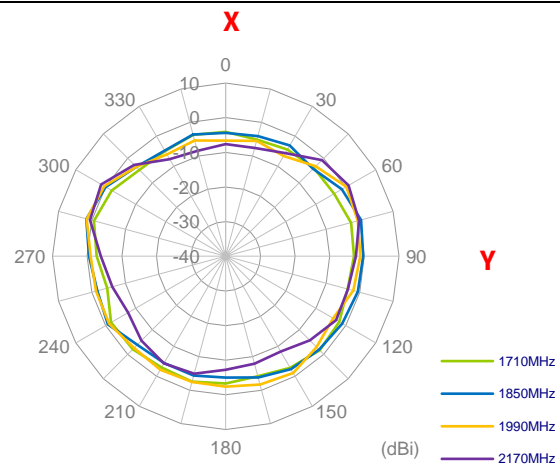
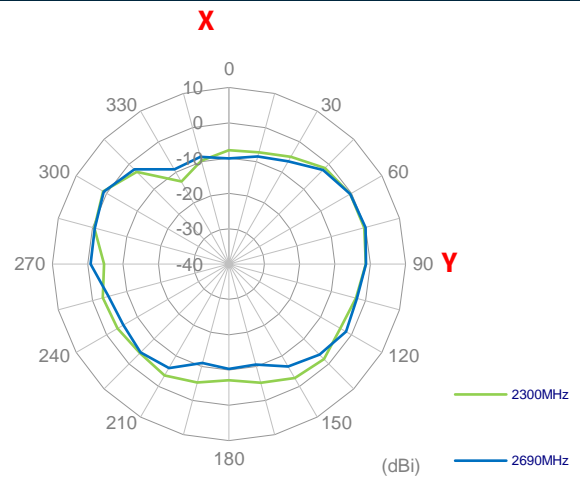
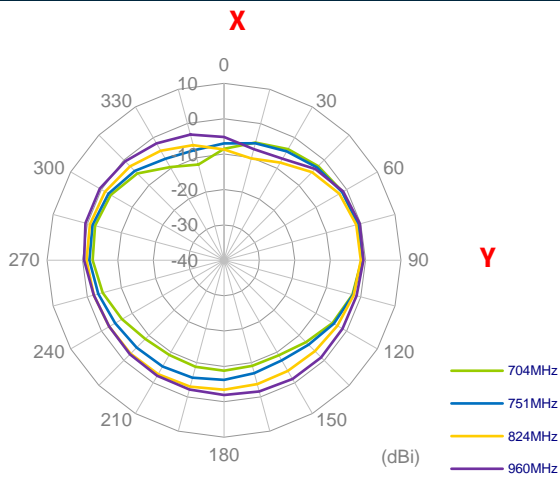

XZ Plane

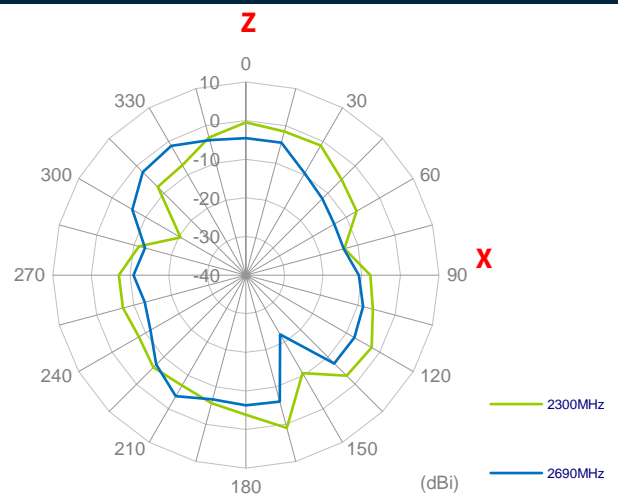
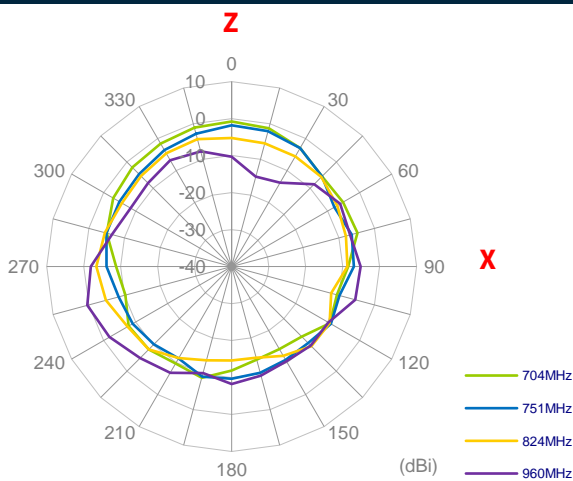

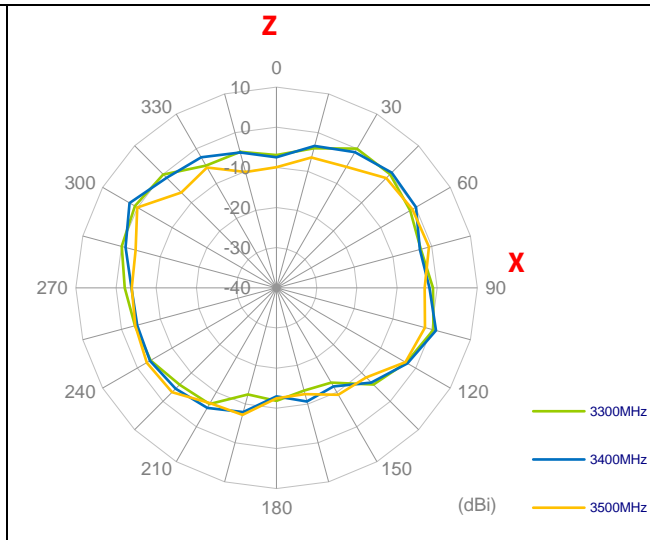
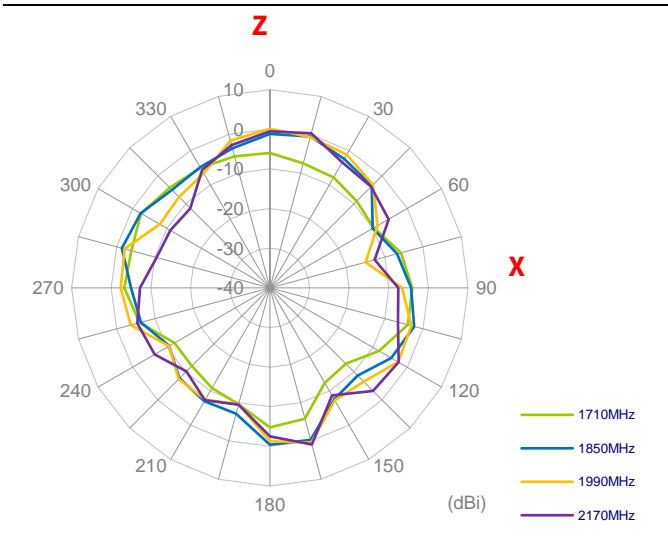

YZ Plane

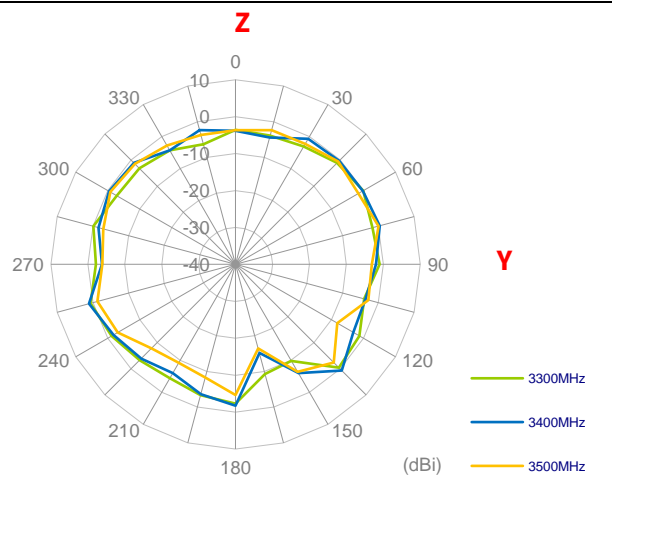
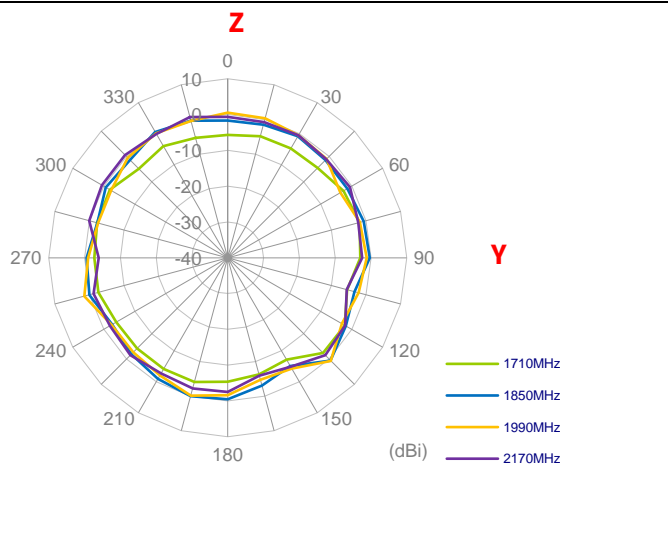
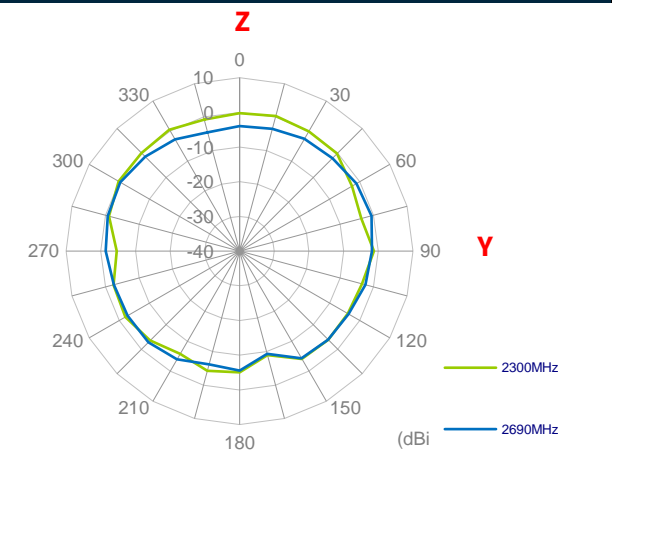
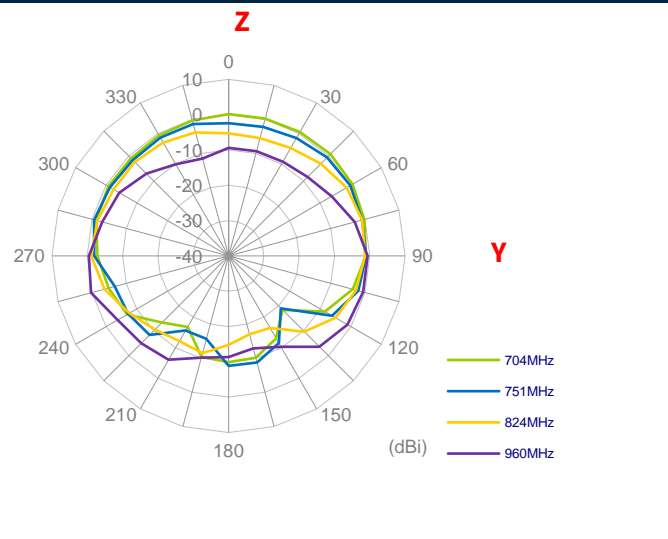

4.4 Wi-Fi MIMO 1

XY Plane

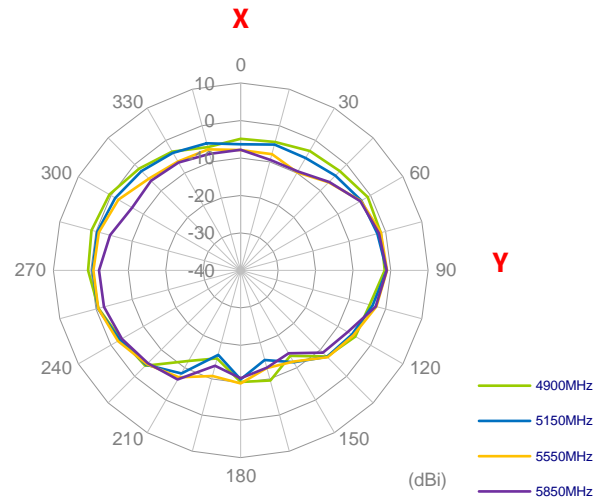
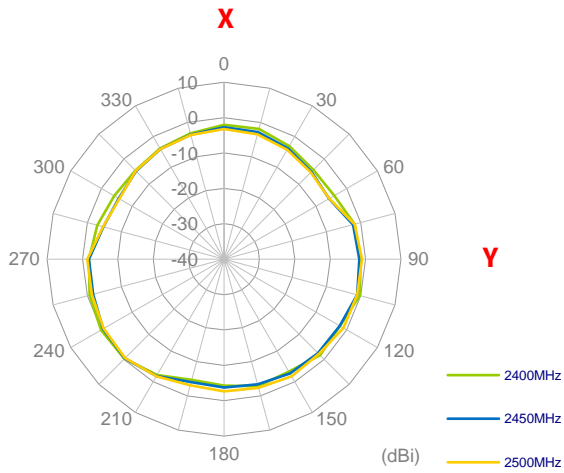

XZ Plane

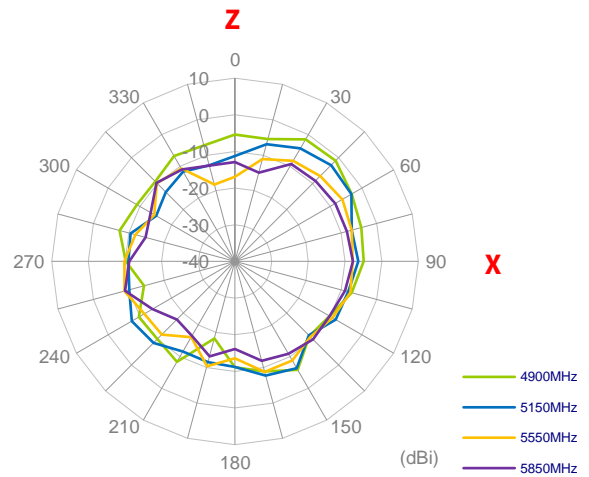
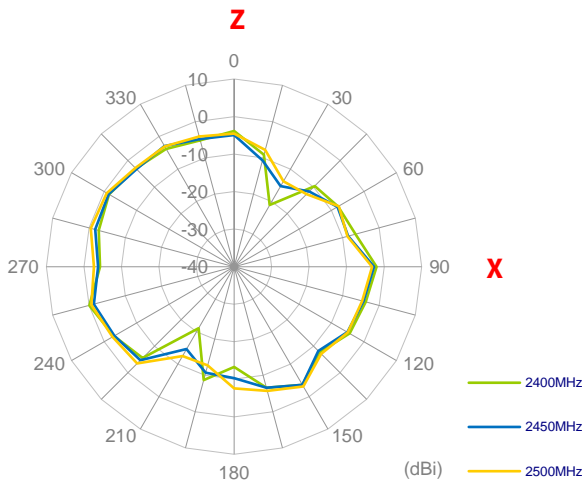

YZ Plane

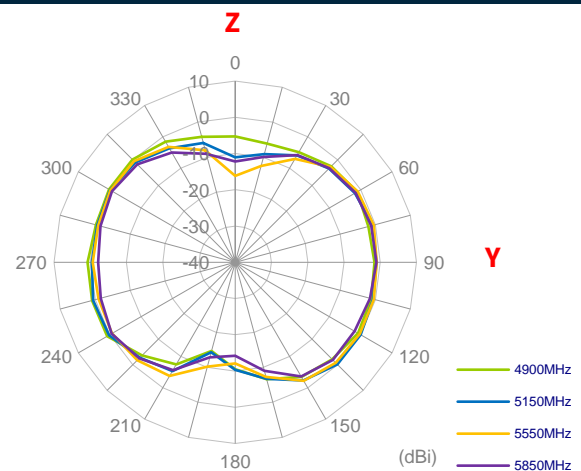
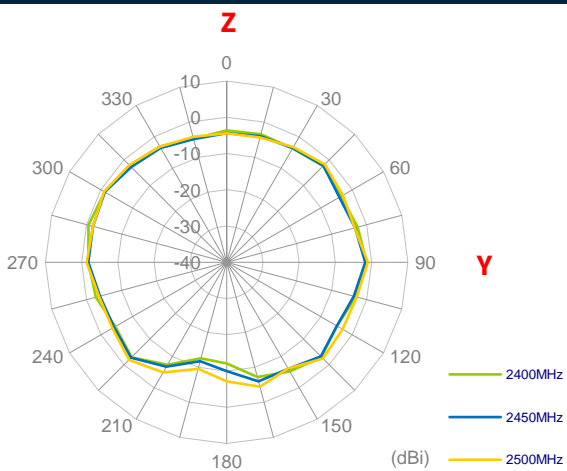

4.5 Wi-Fi MIMO 2

XY Plane

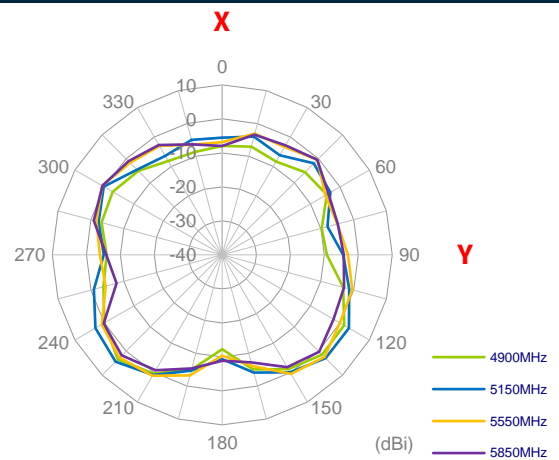
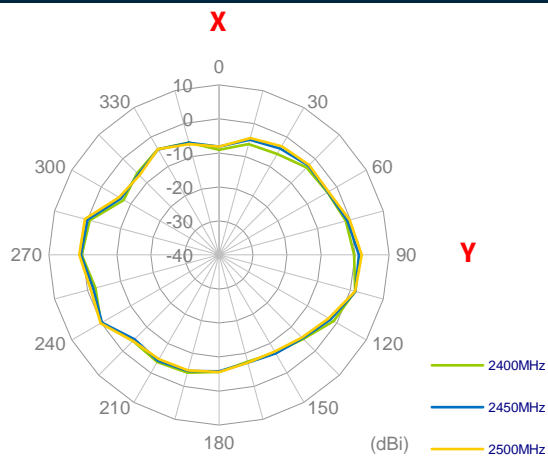

XZ Plane

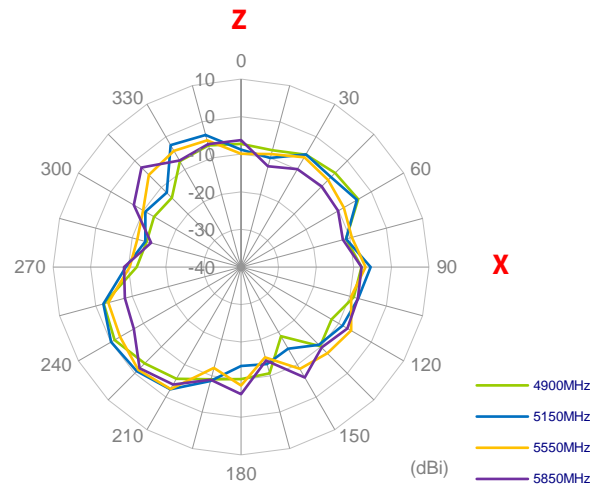
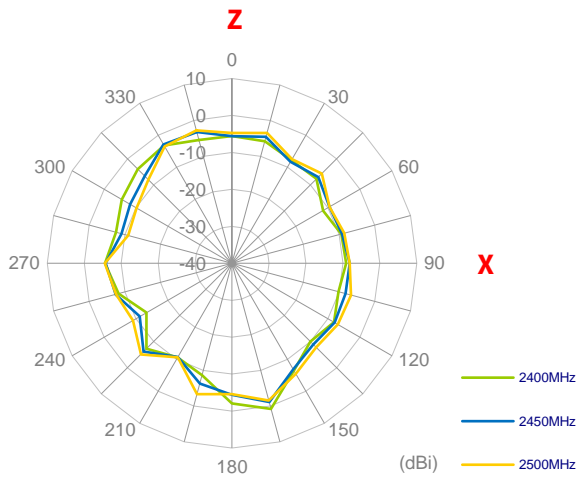

YZ Plane

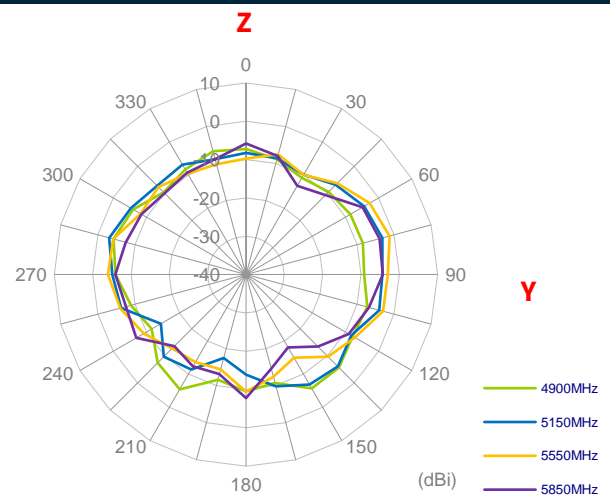
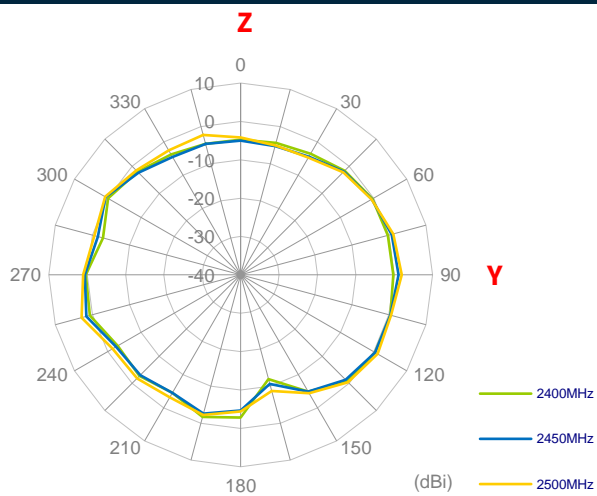

4.5 GNSS

XY Plane

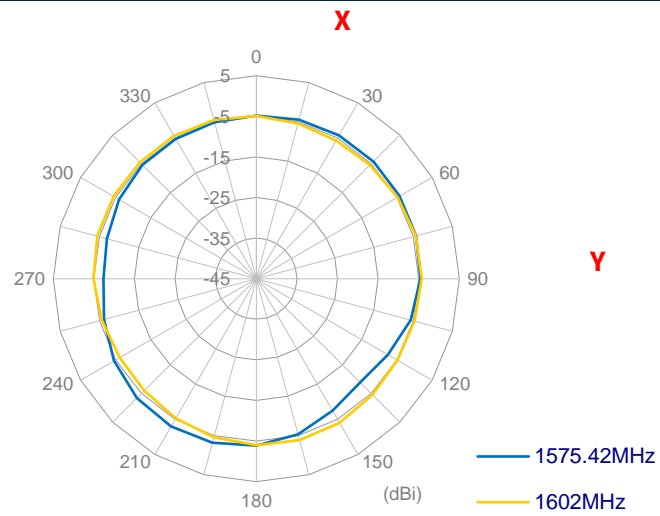

XZ Plane

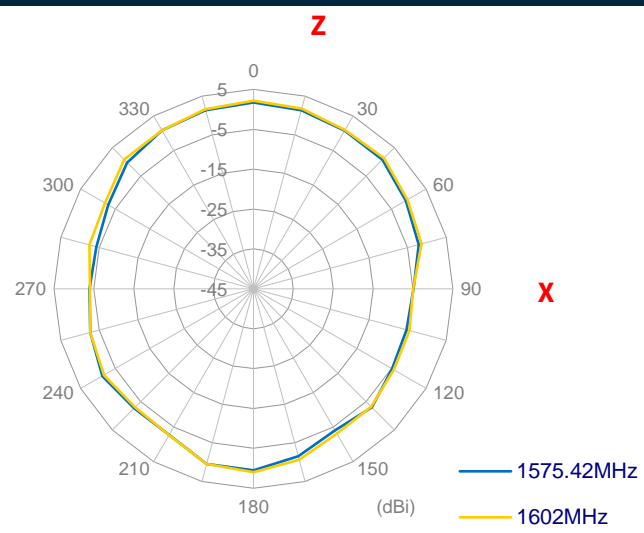

YZ Plane

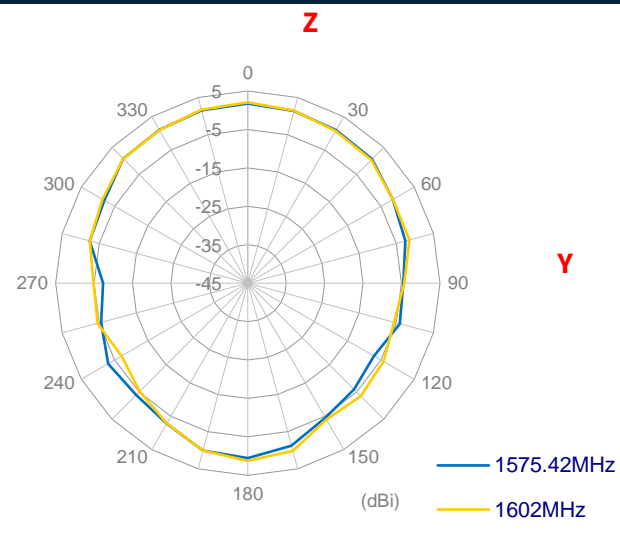

5. 3D Radiation Patterns

5.1 LTE MIMO 1

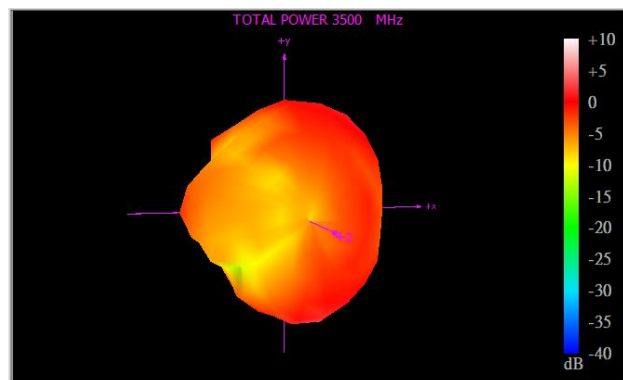
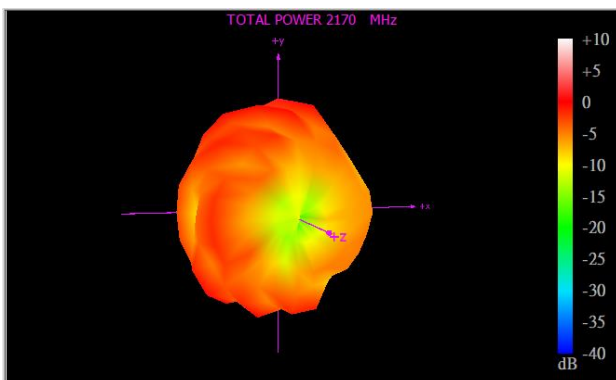
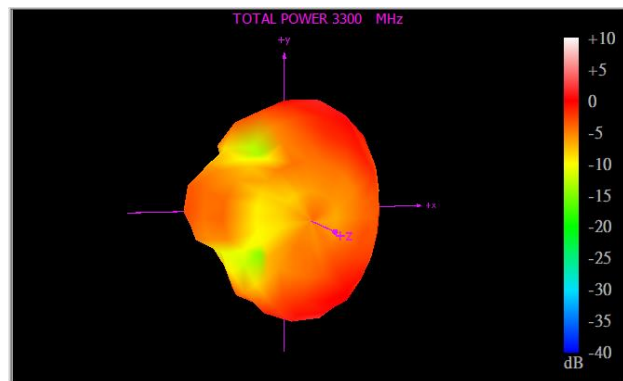
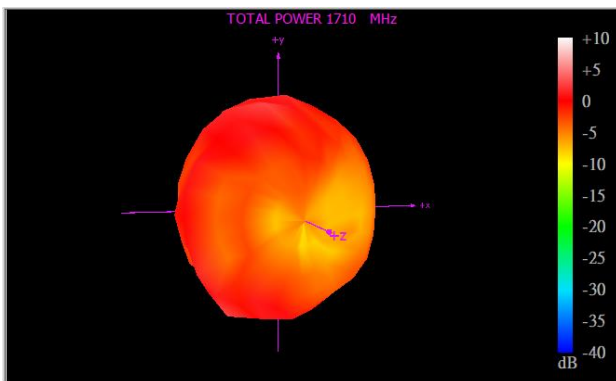
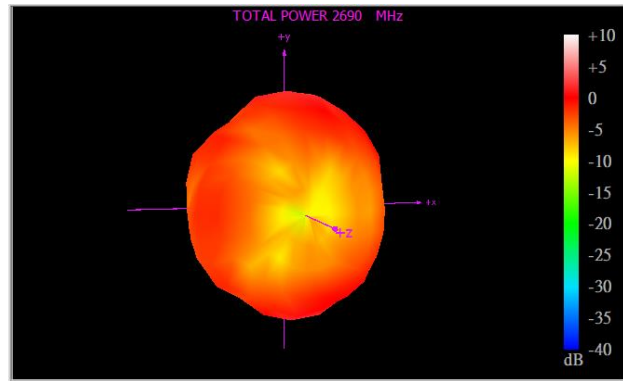
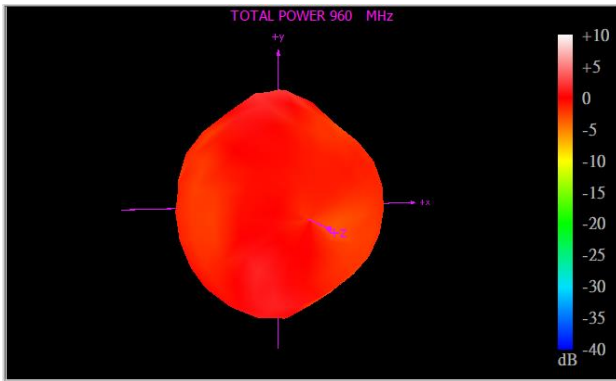
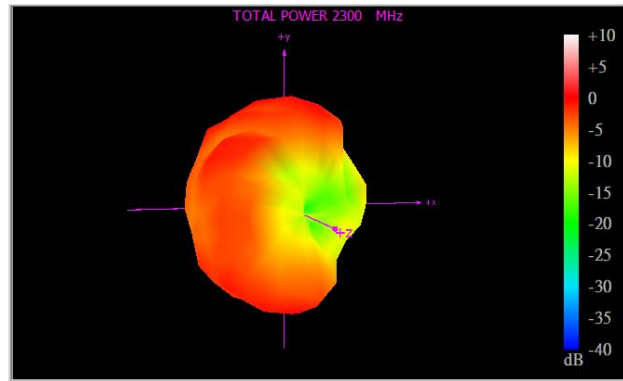
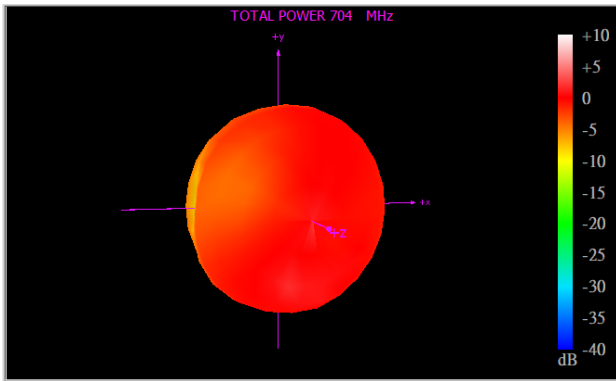

5.2 LTE MIMO 2

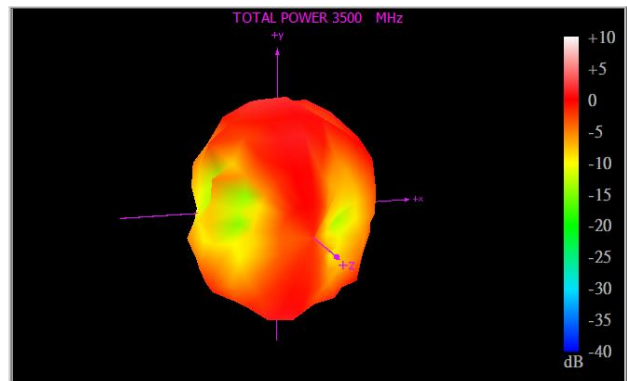
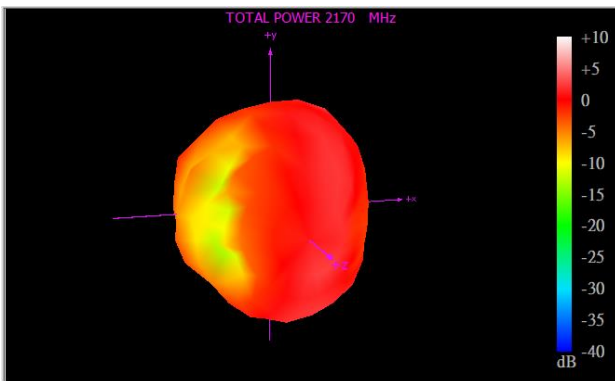
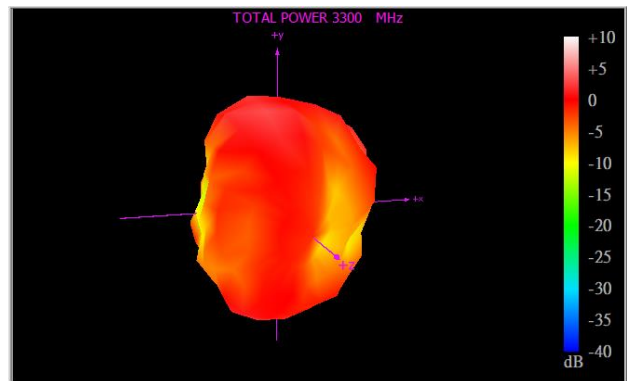
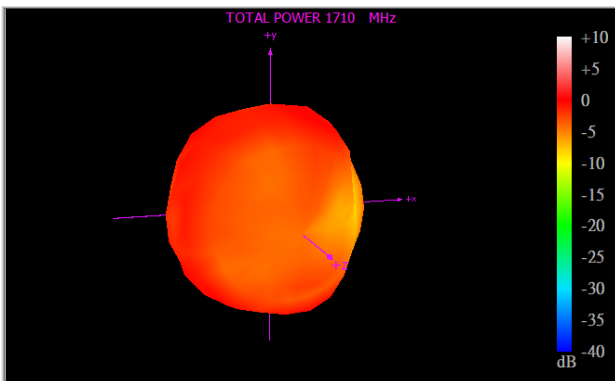
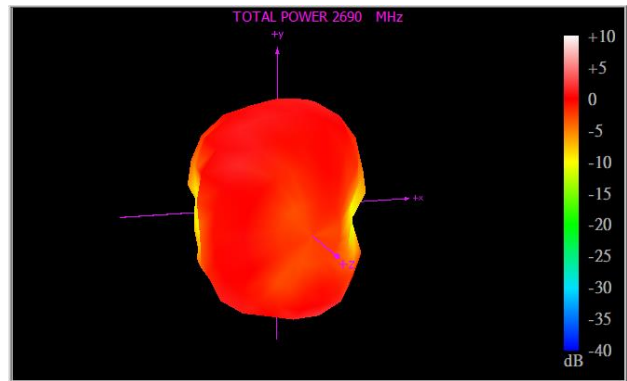
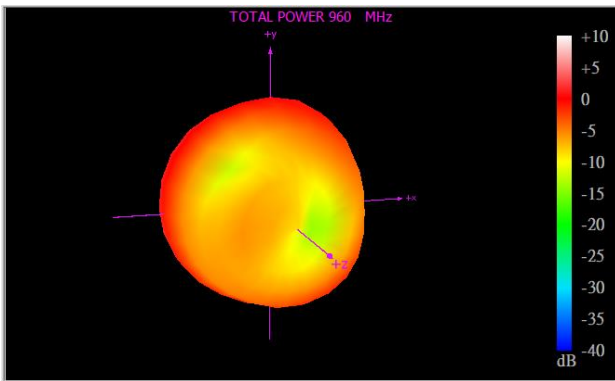
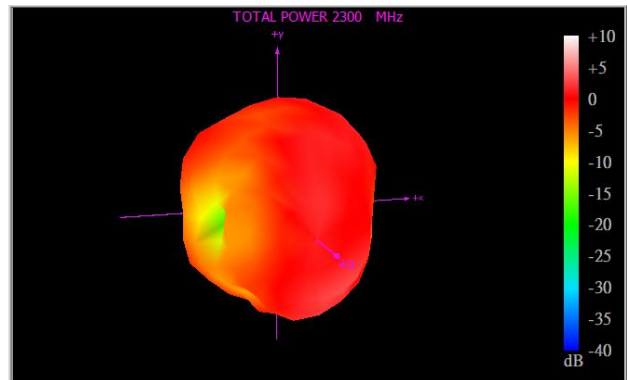
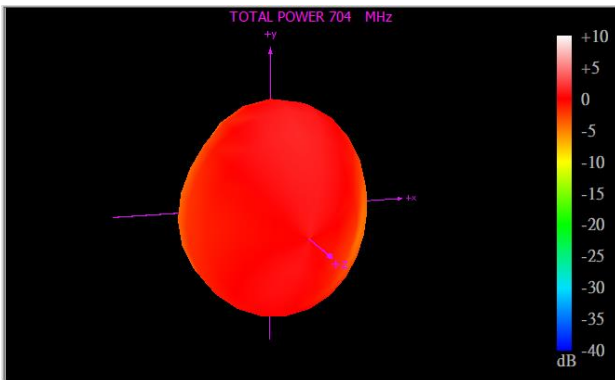

5.3 Wi-Fi MIMO 1

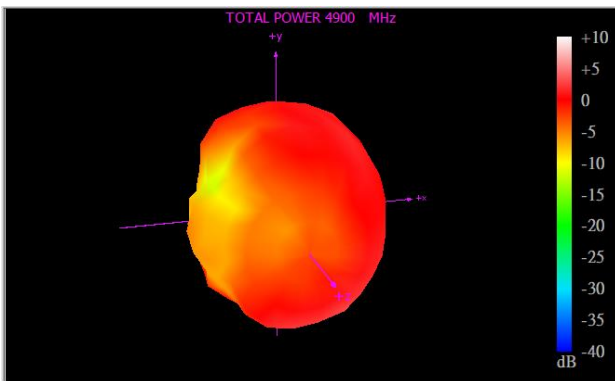
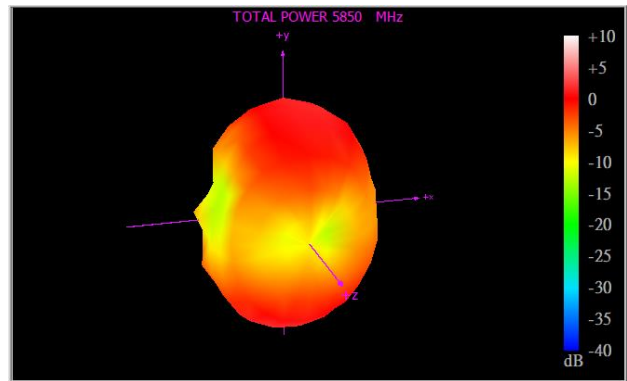
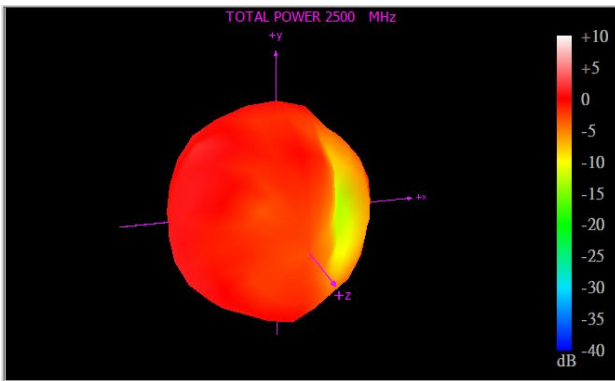
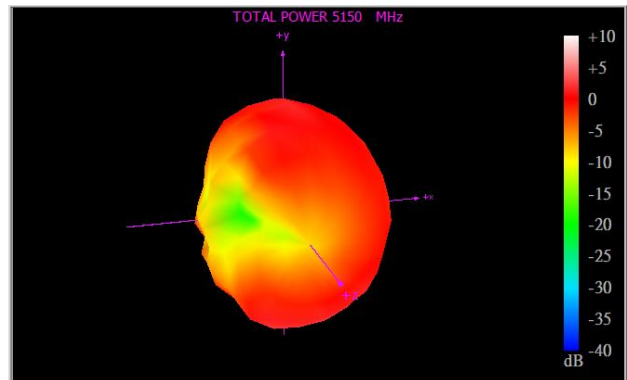
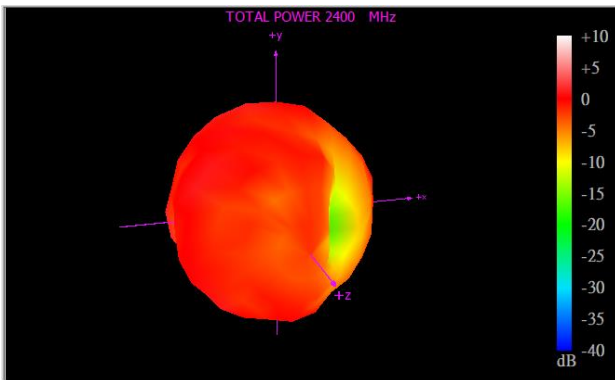

5.4 Wi-Fi MIMO 2

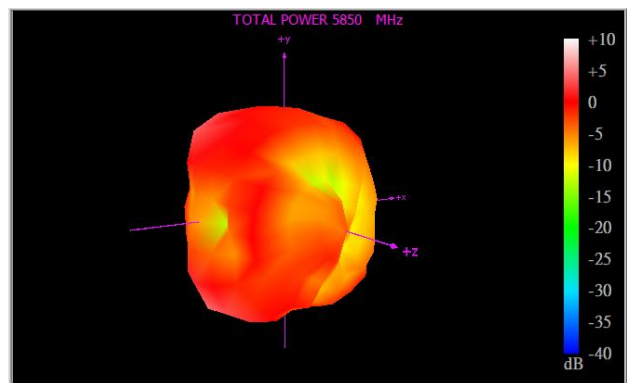
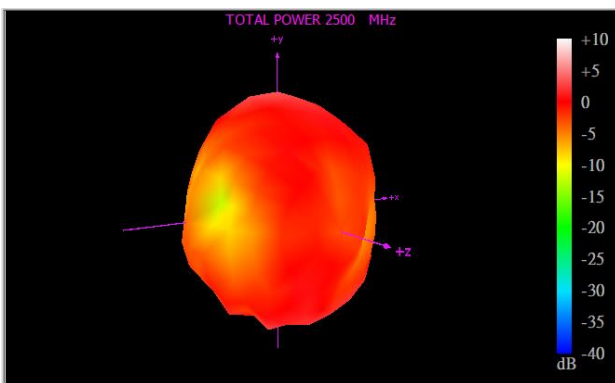
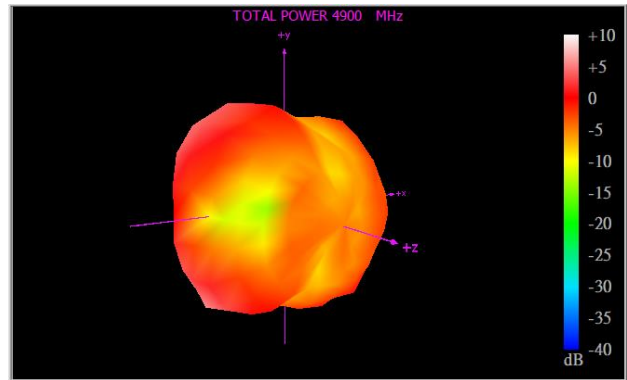
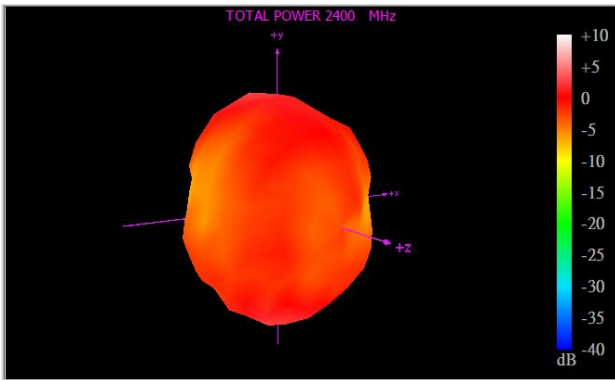

5.5 GNSS

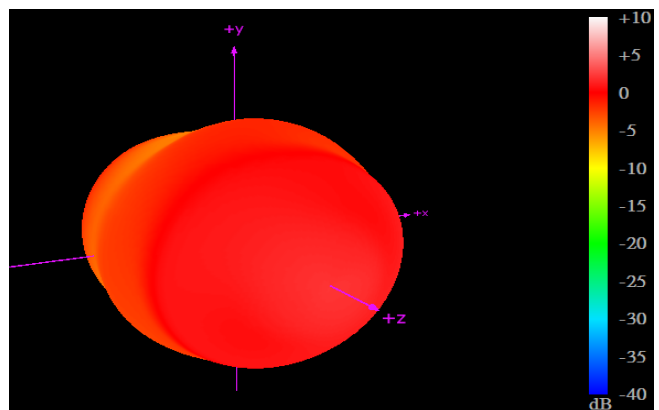
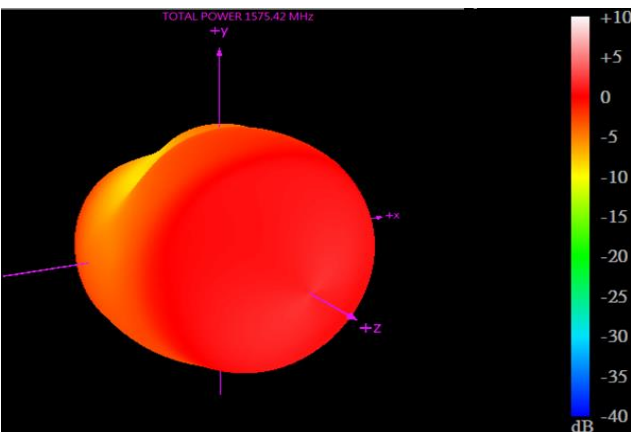

6. Mechanical Drawing (Units: mm)

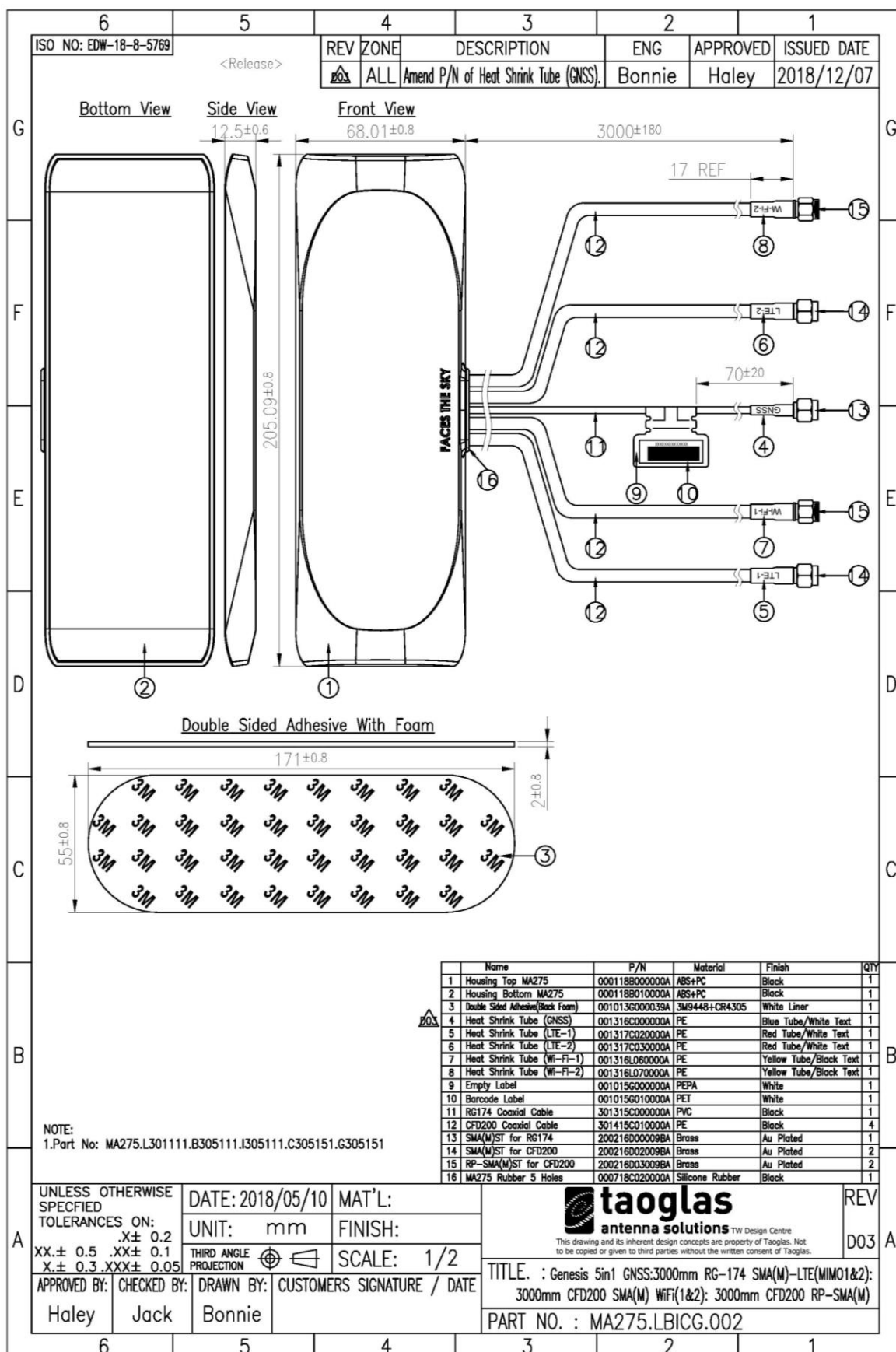

7. Packaging

1pc MA275.LBICG.002 per PE Bag
 Dimensions - 360*300mm
 Weight - 550g

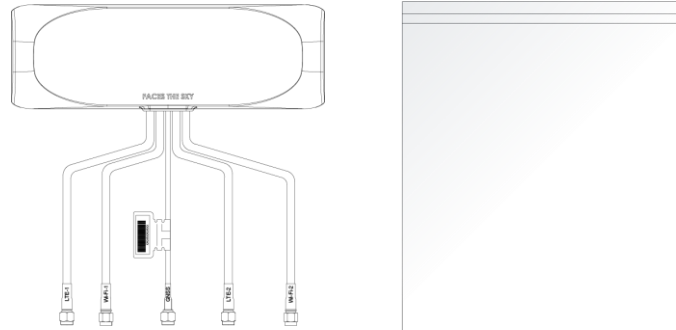

20pcs MA275.LBICG.002 per Carton
 Dimensions - 360*360*400mm
 Weight - 11.86Kg

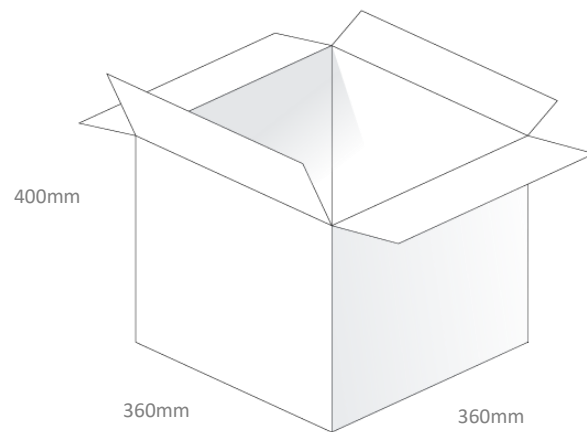

Pallet Dimensions:
 1100*1100*1400mm
 27 Cartons Per Pallet
 9 Cartons Per Layer, 4 Layers

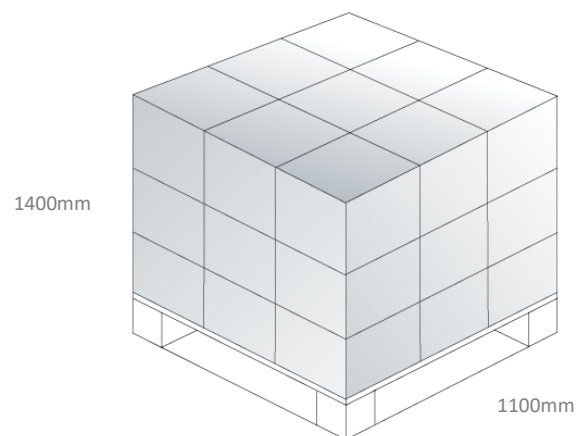

8. Application Note

8.1 Return Loss – LTE MIMO 1

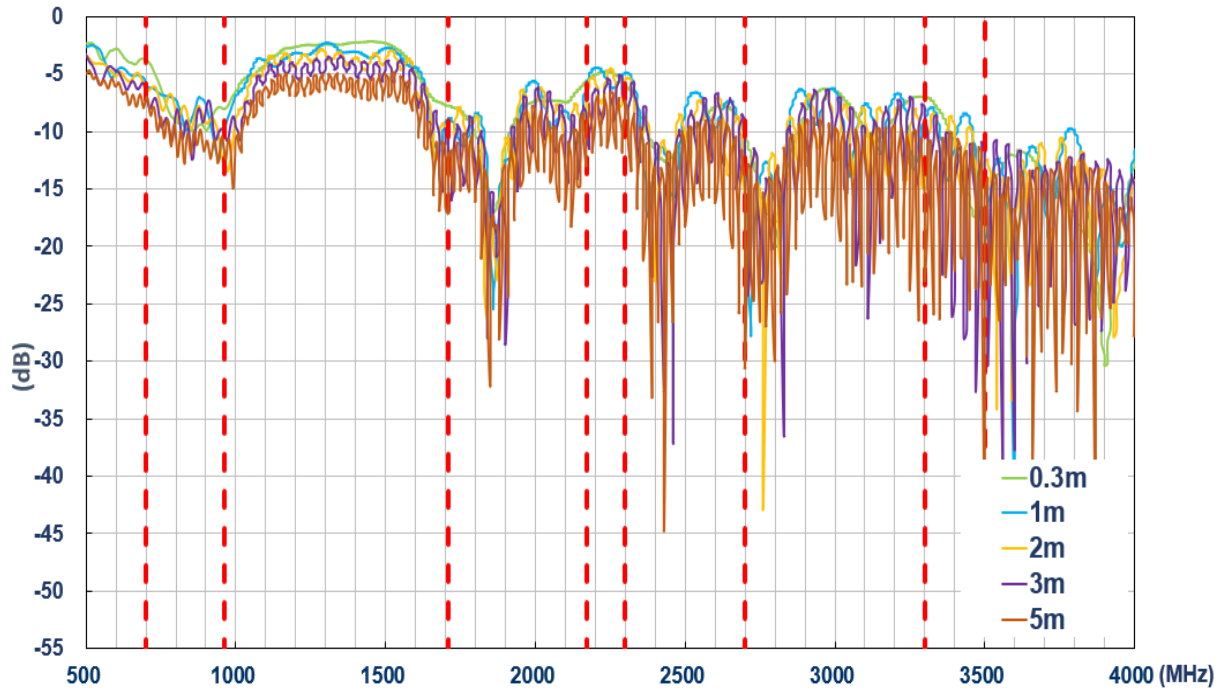

8.2 Return Loss – LTE MIMO 2

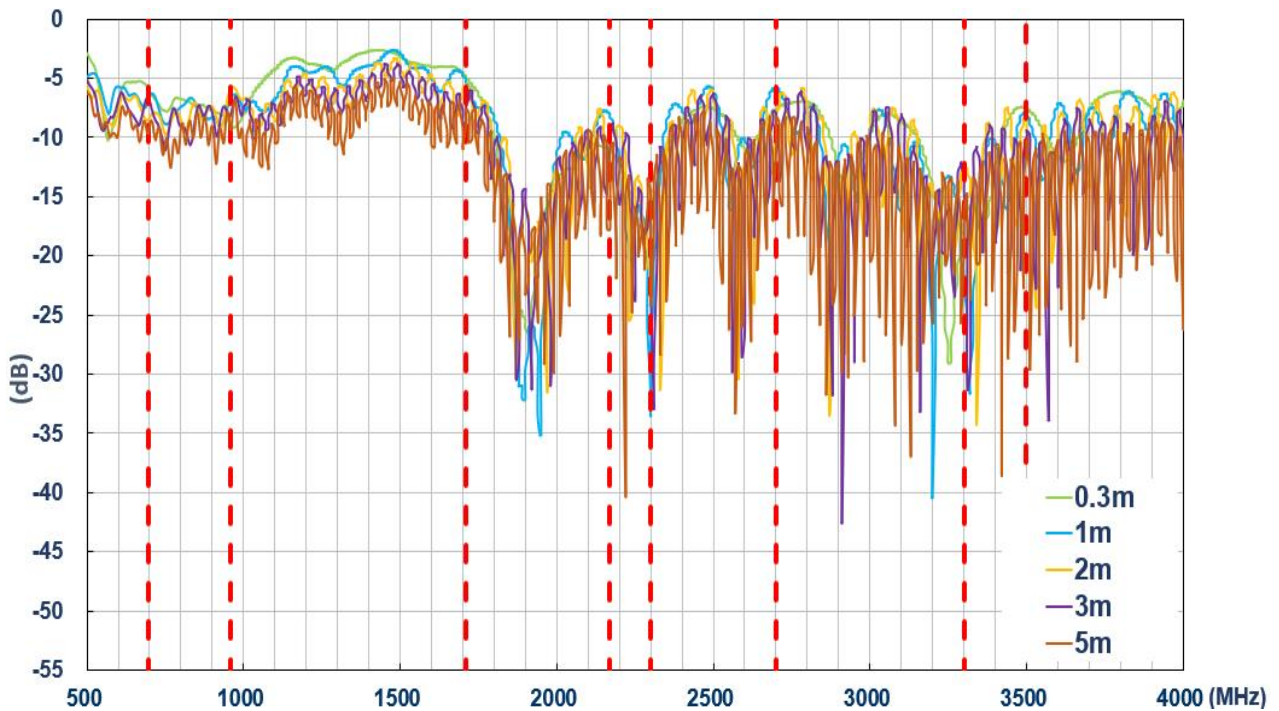

8.3 Return Loss – Wi-Fi MIMO 1

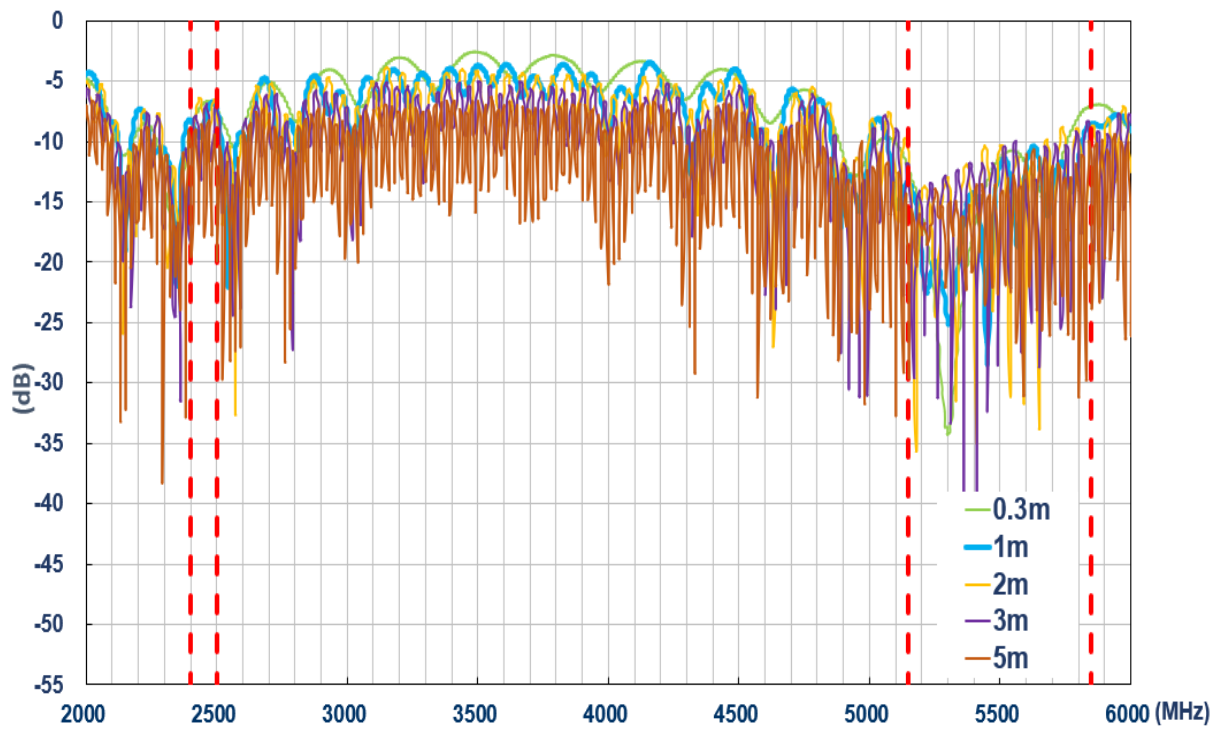

8.4 Return Loss – Wi-Fi MIMO 2

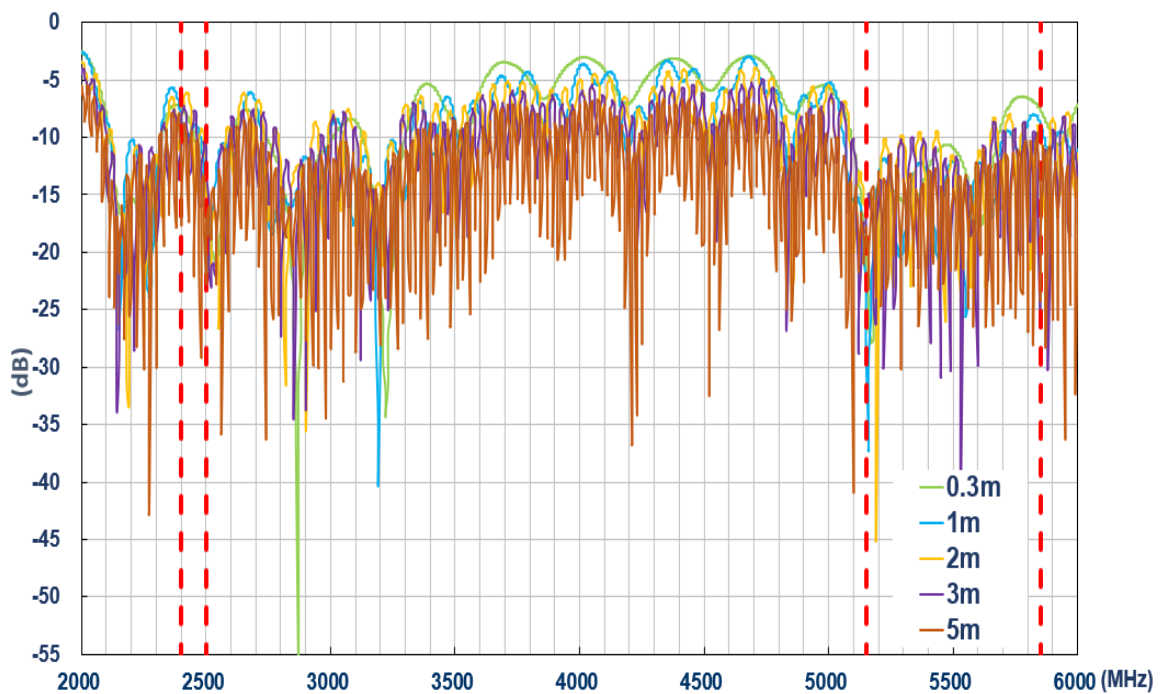

8.5 Isolation – LTE MIMO

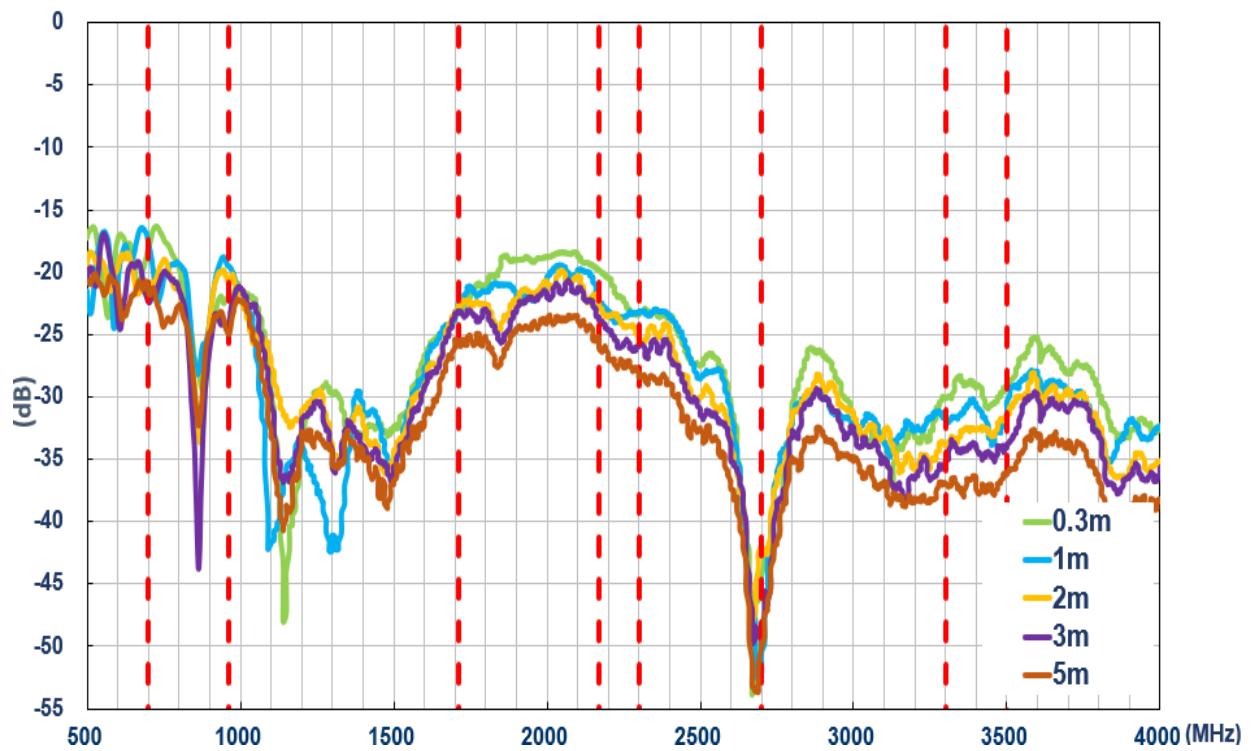

8.6 Isolation – Wi-Fi MIMO

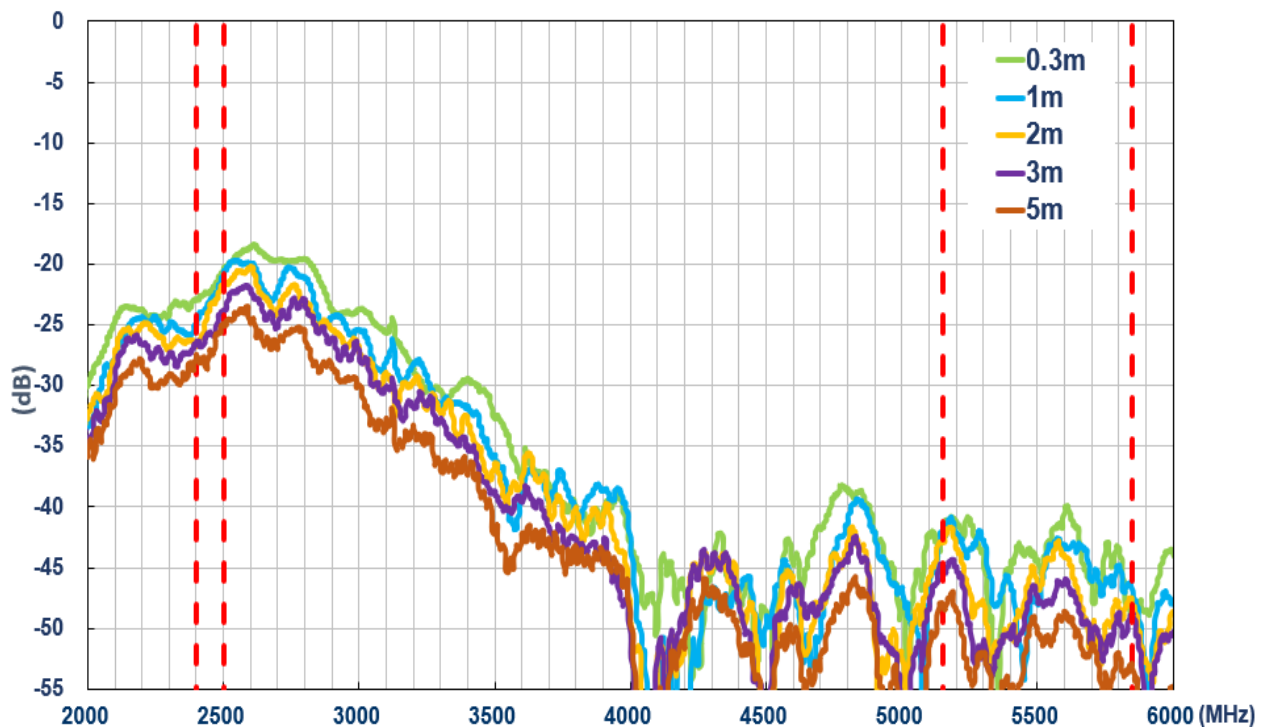

8.7 Efficiency – LTE MIMO 1

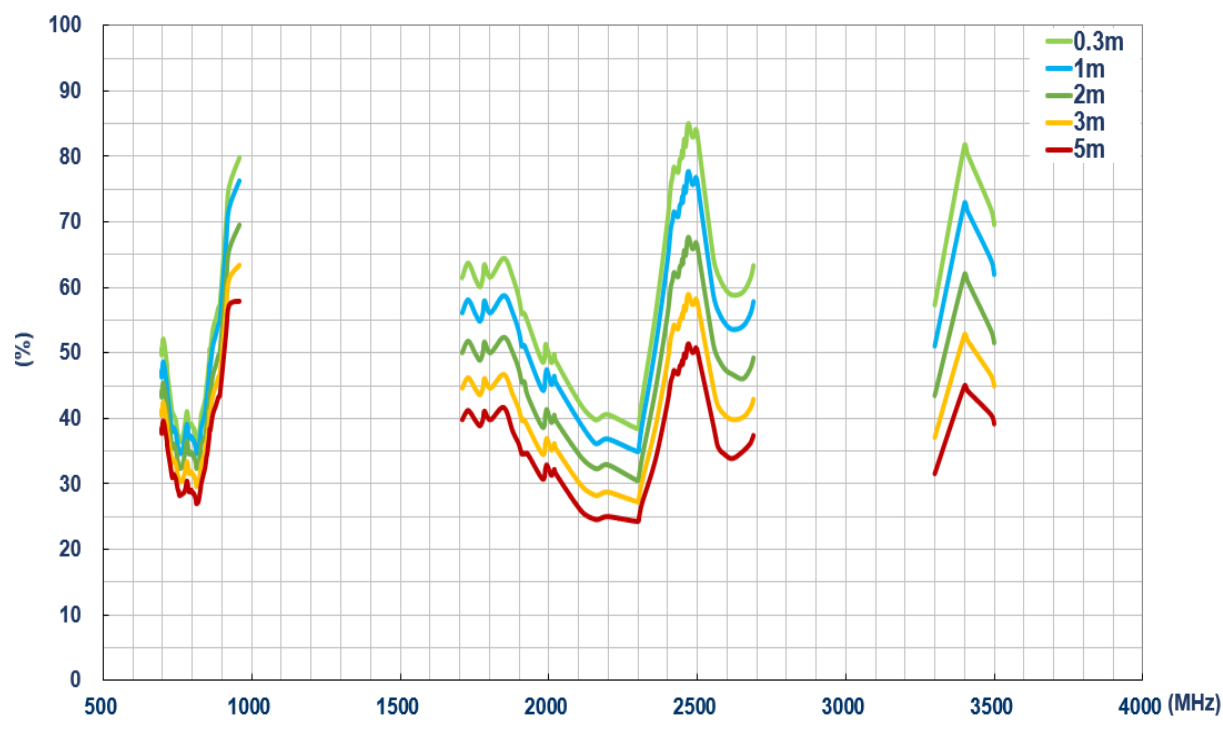

8.8 Efficiency – LTE MIMO 2

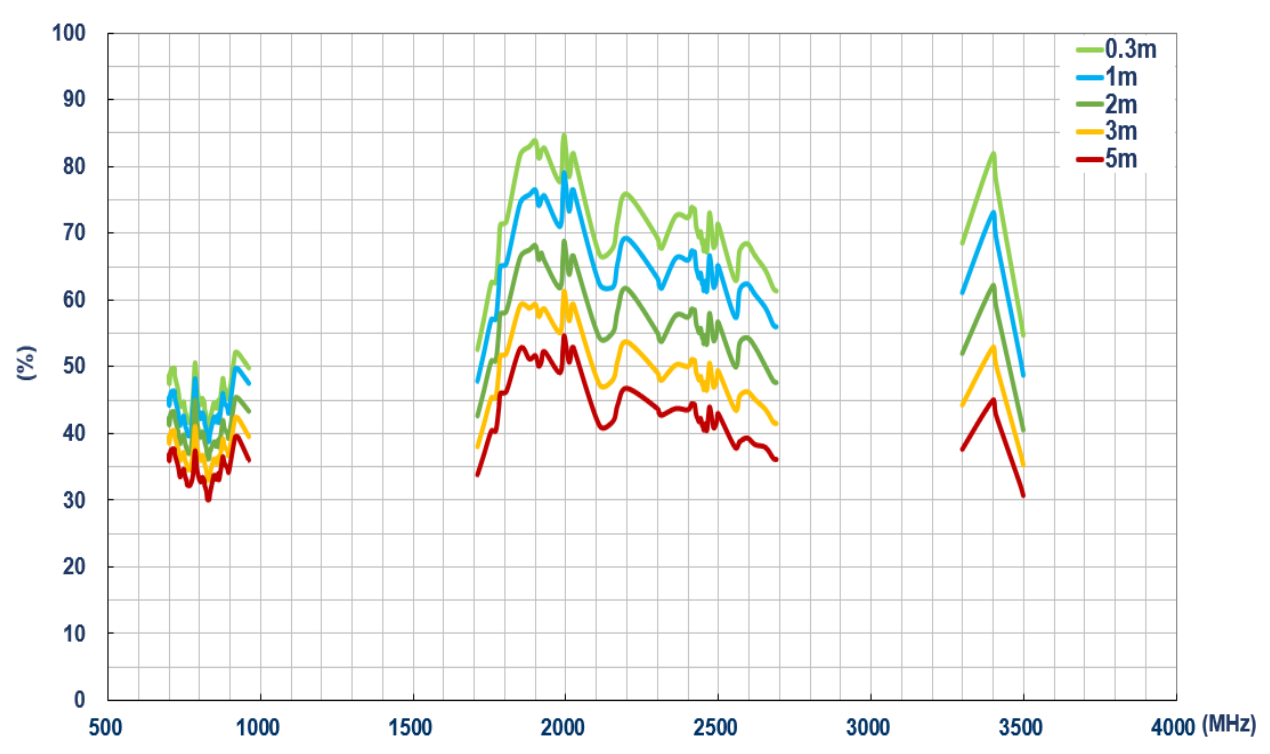

8.9 Efficiency – Wi-Fi MIMO 1

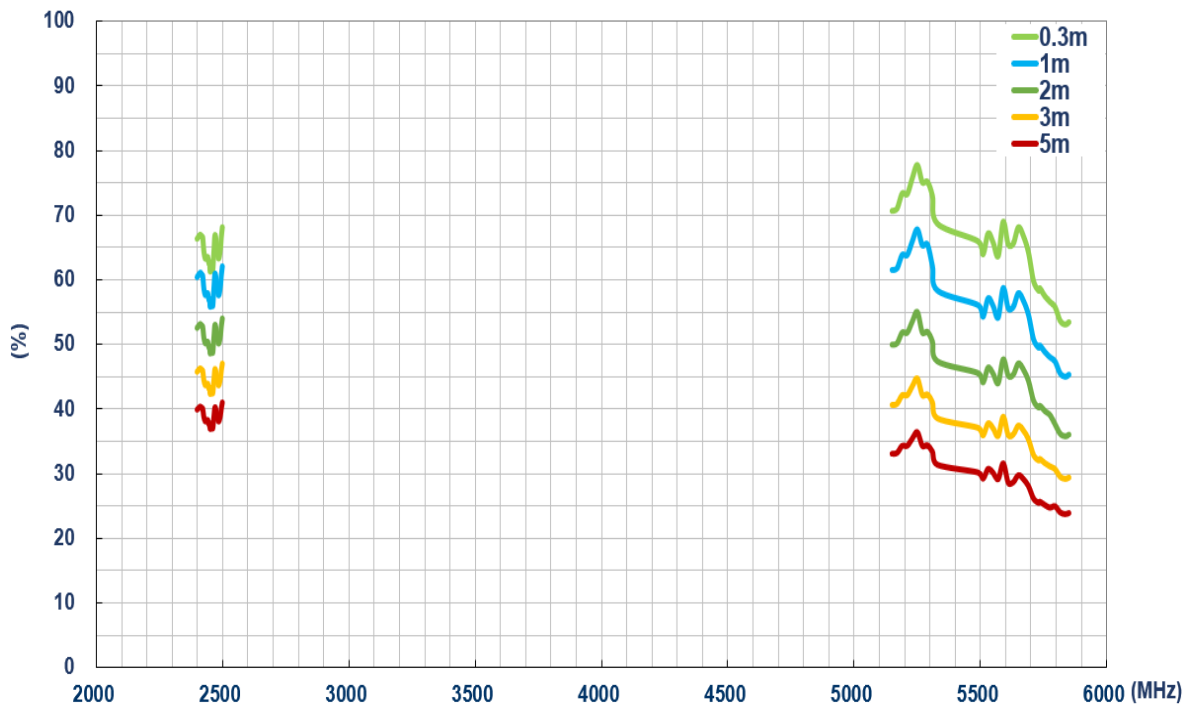

8.10 Efficiency – Wi-Fi MIMO 2

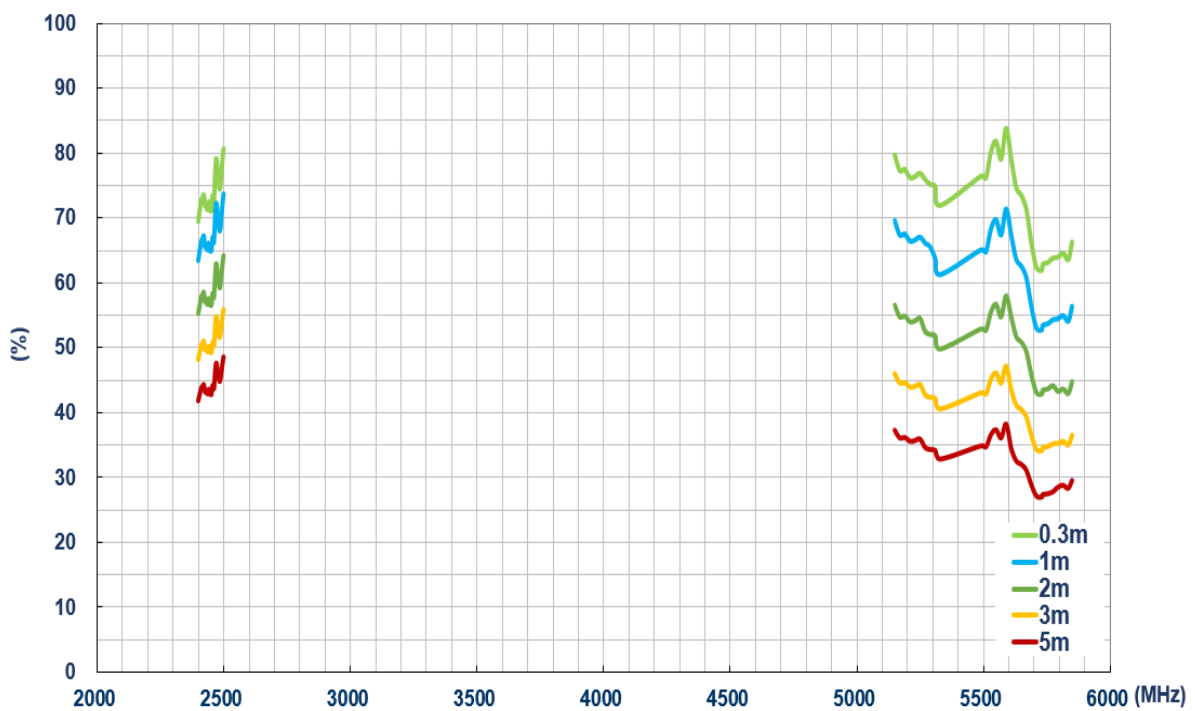

8.11 Average Gain – LTE MIMO 1

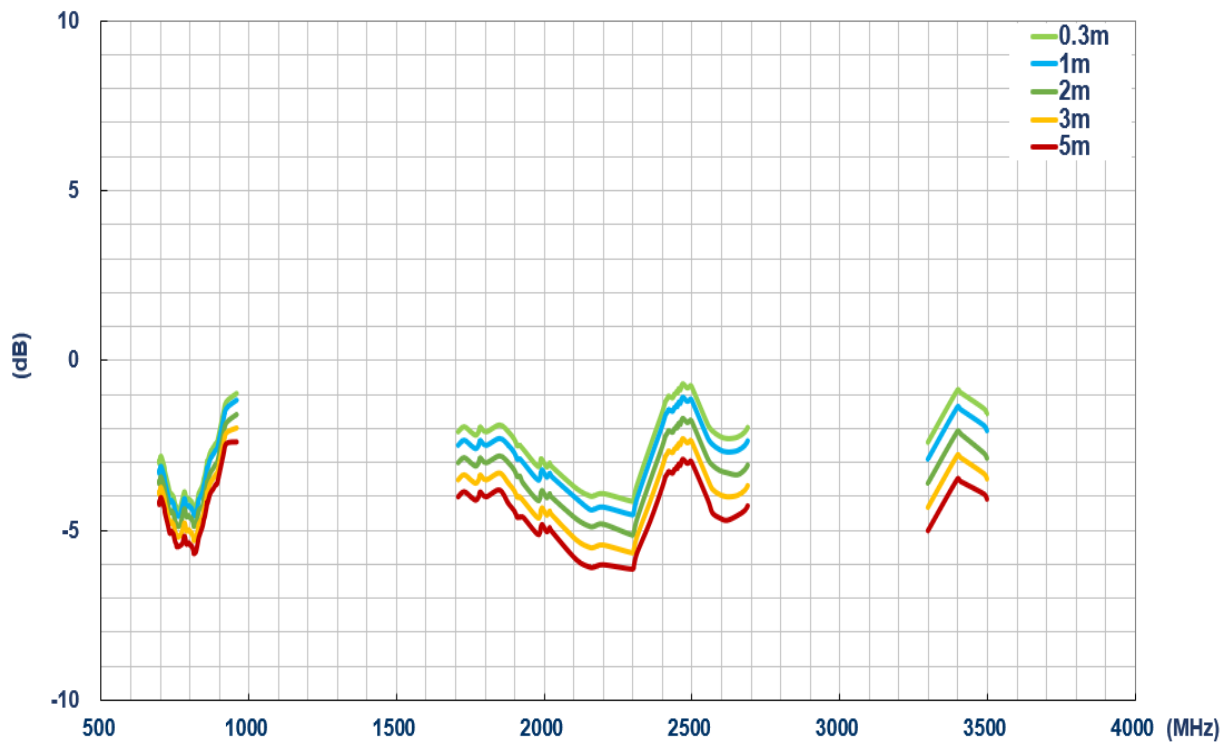

8.12 Average Gain – LTE MIMO 2

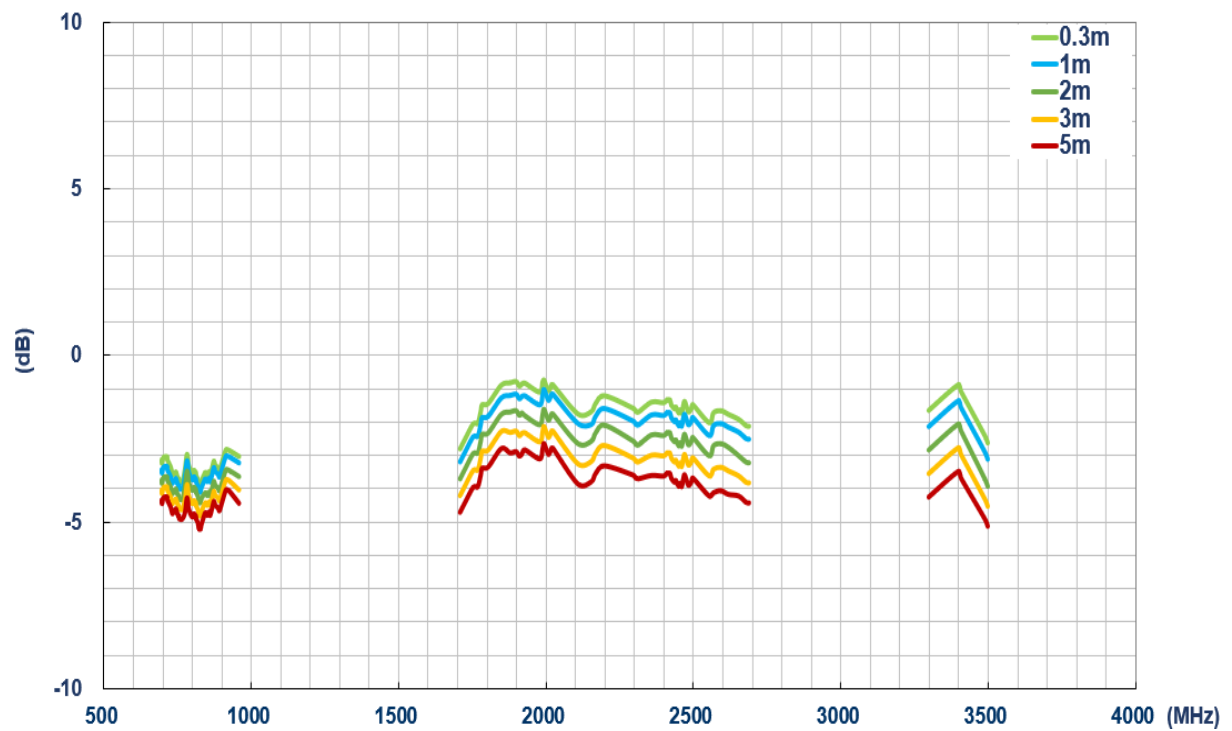

8.13 Average Gain – Wi-Fi MIMO 1

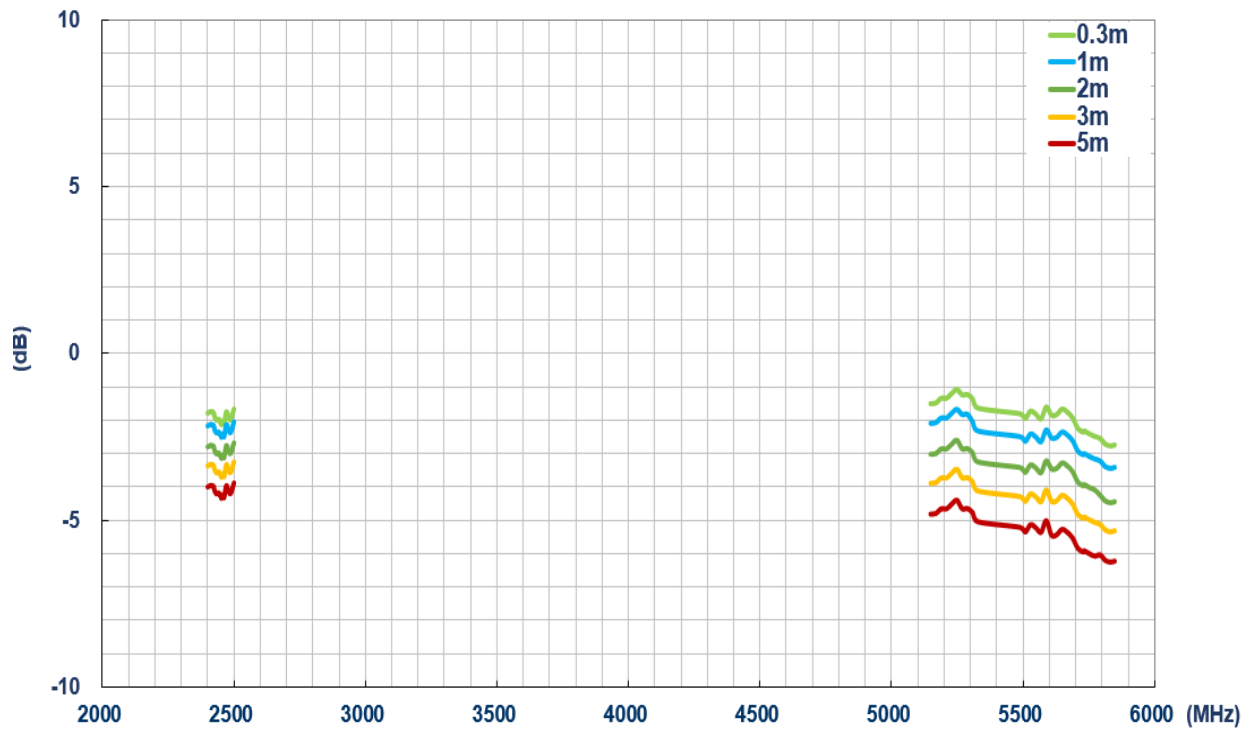

8.14 Average Gain – Wi-Fi MIMO 2

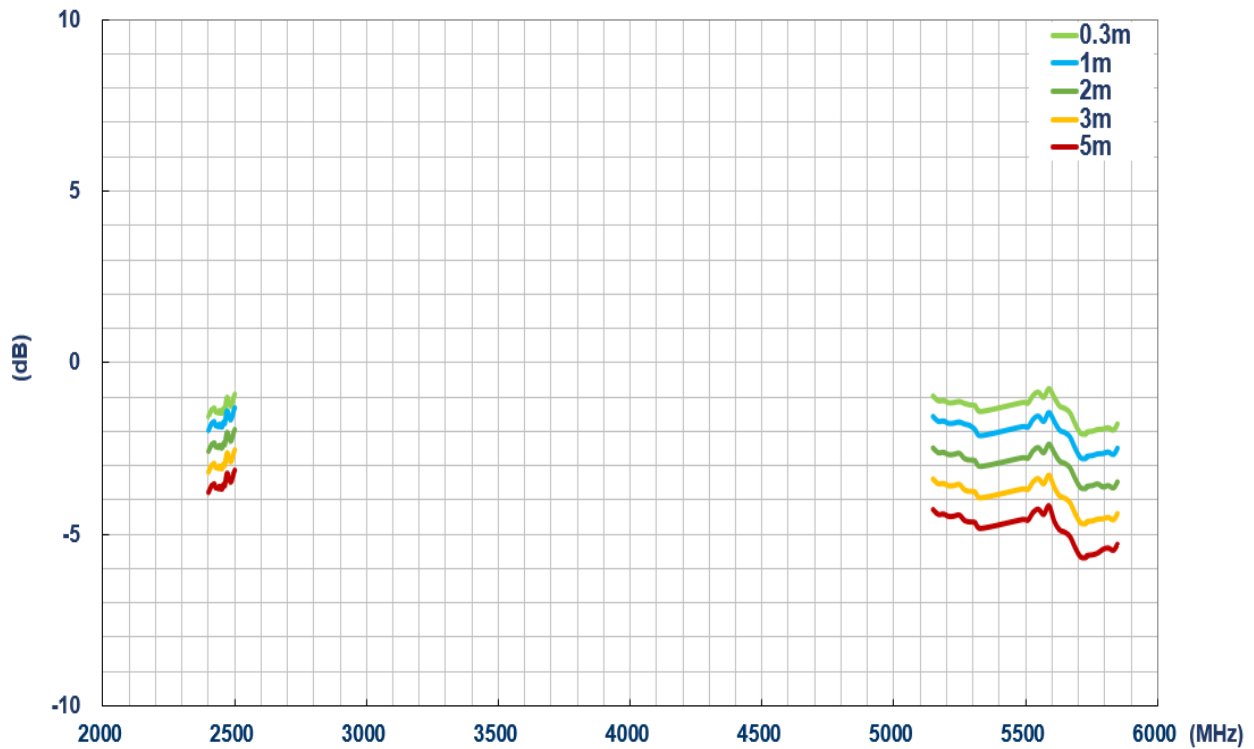

8.15 Peak Gain – LTE MIMO 1

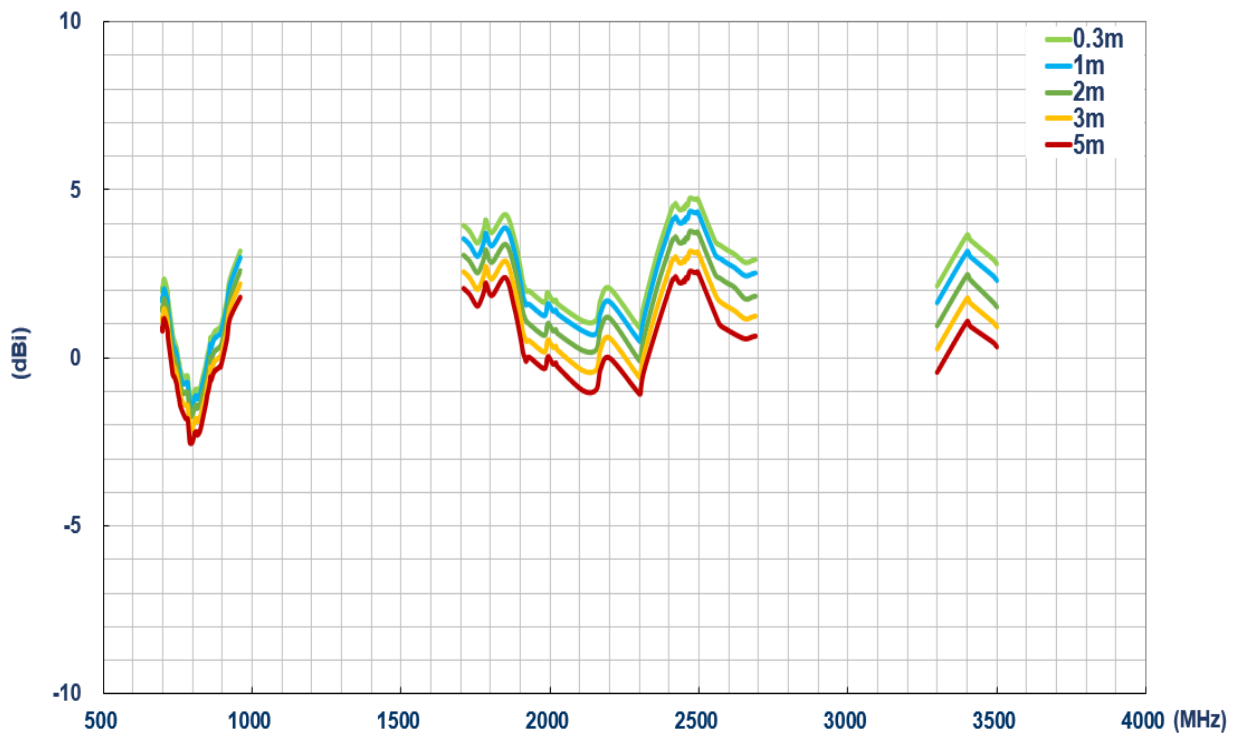

8.16 Peak Gain – LTE MIMO 2

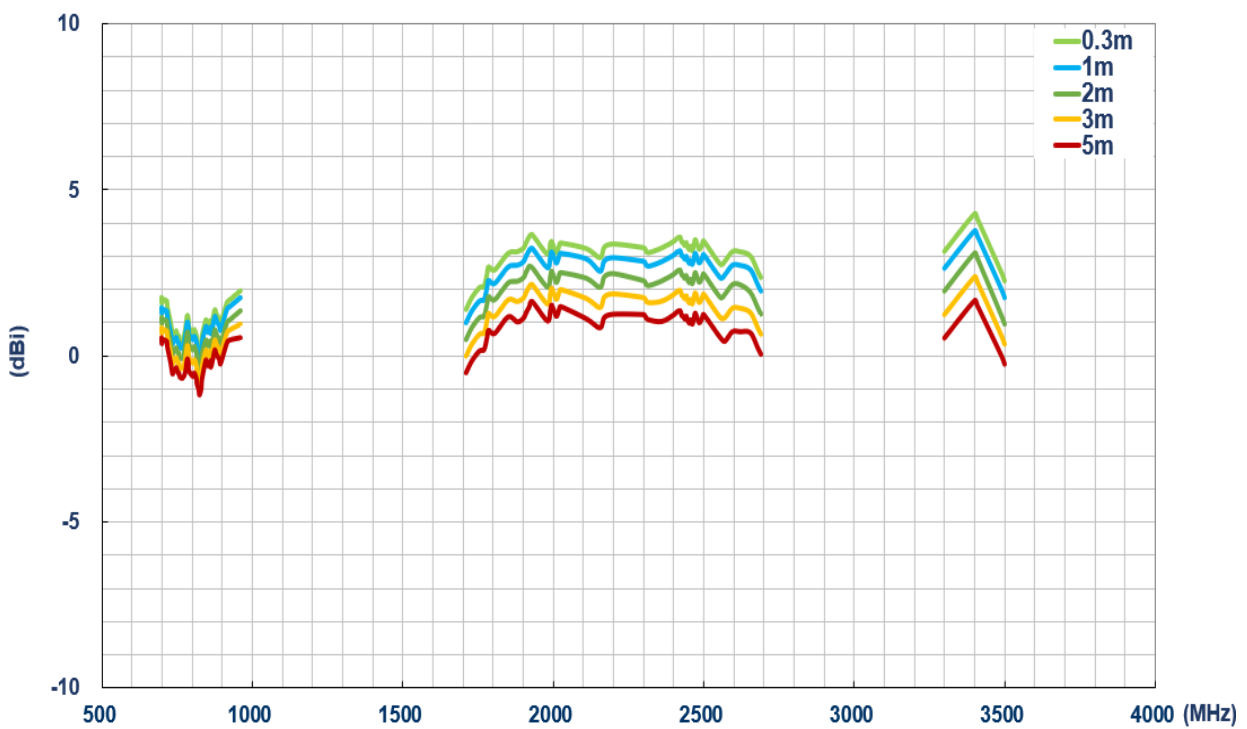

8.17 Peak Gain – Wi-Fi MIMO 1

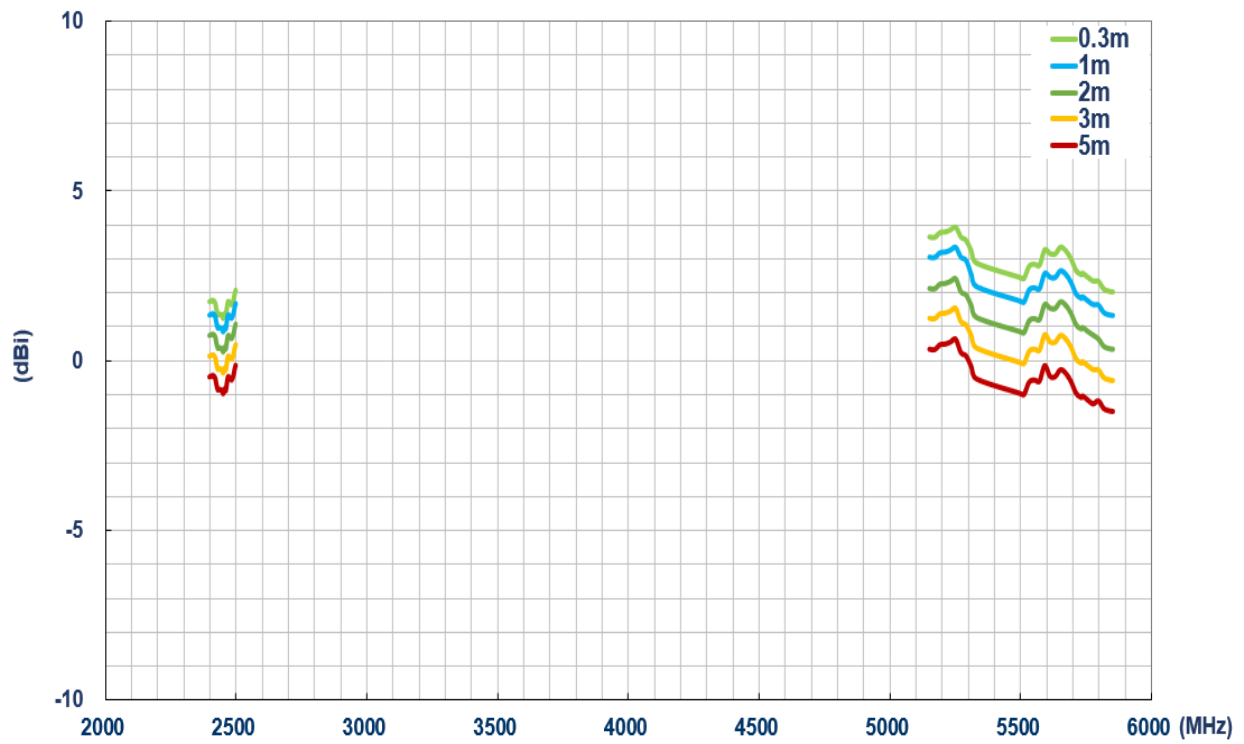

8.18 Peak Gain – Wi-Fi MIMO 2

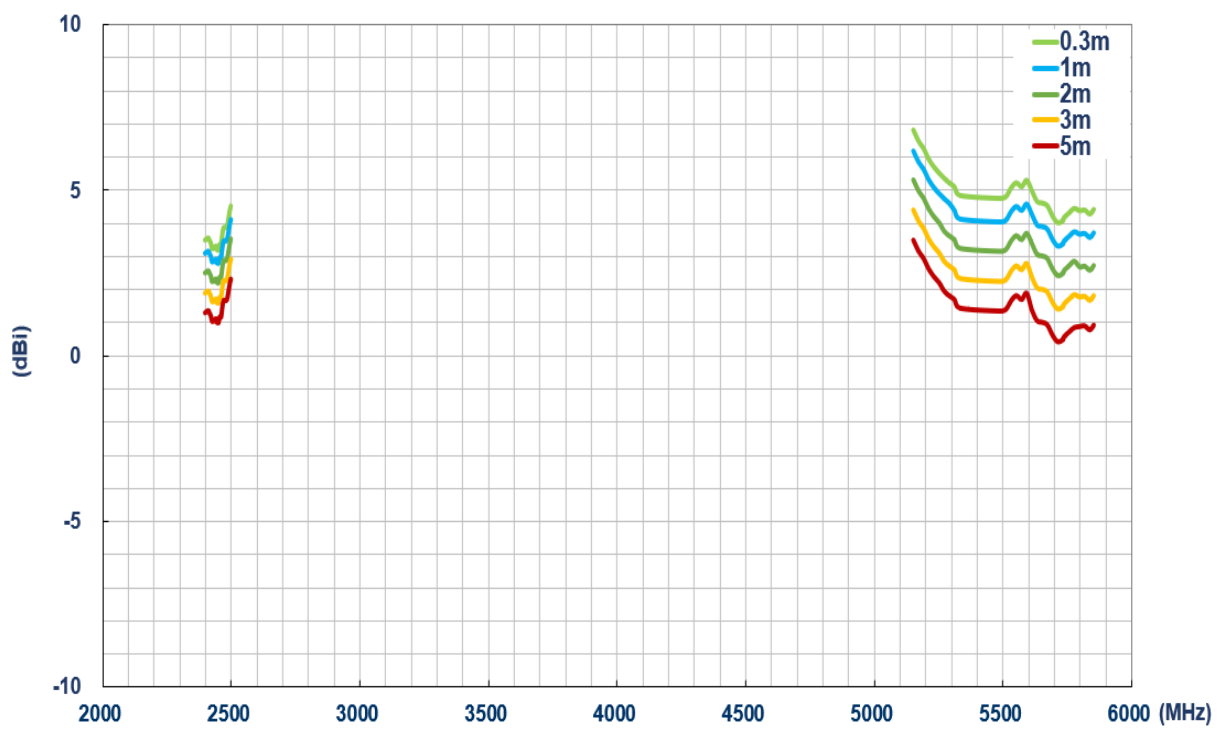

Changelog for the datasheet

SPE-19-8-056 – MA275.A.LBICG.002

Revision: A (Original First Release)

Date:	2019-05-02
Notes:	
Author:	Jack Conroy

Previous Revisions



TAOGLAS®

www.taoglas.com



X-ON Electronics

Largest Supplier of Electrical and Electronic Components

Click to view similar products for [Antennas](#) category:

Click to view products by [Taoglas](#) manufacturer:

Other Similar products are found below :

[GAN30084EU](#) [930-033-R](#) [GW17.07.0250E](#) [1513563-1](#) [EXE902SM](#) [APAMPG-117](#) [MAF94383](#) [W3908B0100](#) [W6102B0100](#) [YE572113-30RSMM](#) [108-00014-50](#) [66089-2406](#) [SPDA17RP918](#) [W3006VP](#) [A09-F8NF-M](#) [A09-F5NF-M](#) [RGFRA1903041A1T](#) [W3593B0100](#) [W3921B0100](#) [SIMNA-868](#) [SIMNA-915](#) [SIMNA-433](#) [W1044](#) [W1049B090](#) [A75-001](#) [WTL2449CQ1-FRSMM](#) [CPL9C](#) [EXB148BN](#) [0600-00060](#) [TRA9020S3PBN-001](#) [Y4503](#) [GD5W-28P-NF](#) [MA9-7N](#) [GD53-25](#) [GD5W-21P-NF](#) [C37](#) [MAF94051](#) [MA9-5N](#) [EXD420PL](#) [B1322NR](#) [QWFTB120](#) [MAF94271](#) [MAF94300](#) [GPSMB301](#) [FG4403](#) [AO-AGSM-OM54](#) [5200232](#) [MIKROE-2349](#) [WCM.01.0111](#) [MIKROE-2393](#)