



# TAOGLAS®



## Datasheet

### Colosseum 4G MIMO

**Part No:**  
MA841.A.BI.002

**Description:**

Colosseum MA841 2in1 4G MIMO Permanent Mount Antenna

**Features:**

2\* 4G MIMO 698~960MHz / 1710~2170MHz / 2490~2690MHz

Screw-Mount [Permanent Mount]

Worldwide 4G Bands including 3G and 2G, CAT M & NB-IoT

IP67 Rated Enclosure

Dimensions: Diameter: 94.3mm, Height: 57.4 mm

1m RG-316 with SMA(M) connectors as standard

Custom Cables and Connectors Available

RoHS & Reach Compliant

1. Introduction	3
2. Specifications	4
3. Antenna Characteristics	5
4. 2D Radiation Patterns	7
5. Mechanical Drawing	11
6. Installation Guide	12
<hr/>	
7. Packaging	13
<hr/>	
Changelog	14

Taoglas makes no warranties based on the accuracy or completeness of the contents of this document and reserves the right to make changes to specifications and product descriptions at any time without notice. Taoglas reserves all rights to this document and the information contained herein.

Reproduction, use or disclosure to third parties without express permission is strictly prohibited.



# 1. Introduction



The Colosseum MA841 antenna is a low profile, heavy-duty, fully IP67 waterproof external M2M antenna for use in worldwide telematics applications which require best in class 4G LTE MIMO performance.

This unique product, only 30mm height, delivers powerful worldwide 4G LTE MIMO antenna technology at 700MHz/800MHz/1700MHz/1800MHz/2600MHz.

#### Typical applications

- Remote Asset and Pipeline Monitoring
- Digital Signage
- HD Video over LTE
- First Responder and Emergency Services
- Automotive Vehicle Tracking and Telematics

4G applications demand high speed data uplink and downlink. High efficiency and high gain MIMO antennas are necessary to achieve the required signal to noise ratio and throughput required to solve these challenges. Taoglas also takes care to have high isolation between the two MIMO antennas to prevent self-interference. Low loss cables are used to keep efficiency high over long cable lengths. In contrast, smaller MIMO antennas with poorer quality thinner cables will have much reduced efficiency and isolation, which would lead to a large drop in system throughput or drops, and may indeed not make a system connection at all.

Cable length and connector types are customizable. Contact your regional Taoglas customer support team for installation instructions or further support.

## 2. Specifications

Electrical							
Frequency (MHz)	698~803	824~894	880~960	1710~1880	1850~1990	1920~2170	2490~2690
Peak Gain (dBi)							
MIMO 1	1.51	2.09	2.72	1.98	1.32	1.04	5.91
MIMO 2	3.56	1.95	1.95	2.37	1.79	2.36	4.99
Average Gain (dB)							
MIMO 1	-3.83	-2.99	-2.16	-3.75	-4.55	-5.13	-3.52
MIMO 2	-3.03	-2.92	-3.19	-3.60	-4.03	-4.52	-3.65
Efficiency (%)							
MIMO 1	41.52	50.61	60.91	42.18	35.37	30.76	44.60
MIMO 2	49.82	51.01	47.98	43.71	39.67	35.53	43.25
Impedance	50Ω						
Polarization	Linear						
VSWR	< 3.5						
Mechanical							
Height	57.4mm						
Base Diameter	94.3mm						
Weight	250g						
Casing	ASA						
Base and Thread	Zinc Alloy						
Cable	1m RG-316						
Connector	SMA(M)ST						
Max Assembly Torque	39.2 N-m						
Environmental							
Operation Temperature	-40°C to 85°C						
Storage Temperature	-40°C to 90°C						
Humidity	Non-condensing 65°C 95% RH						

### 3. Antenna Characteristics

#### 3.1 Return Loss

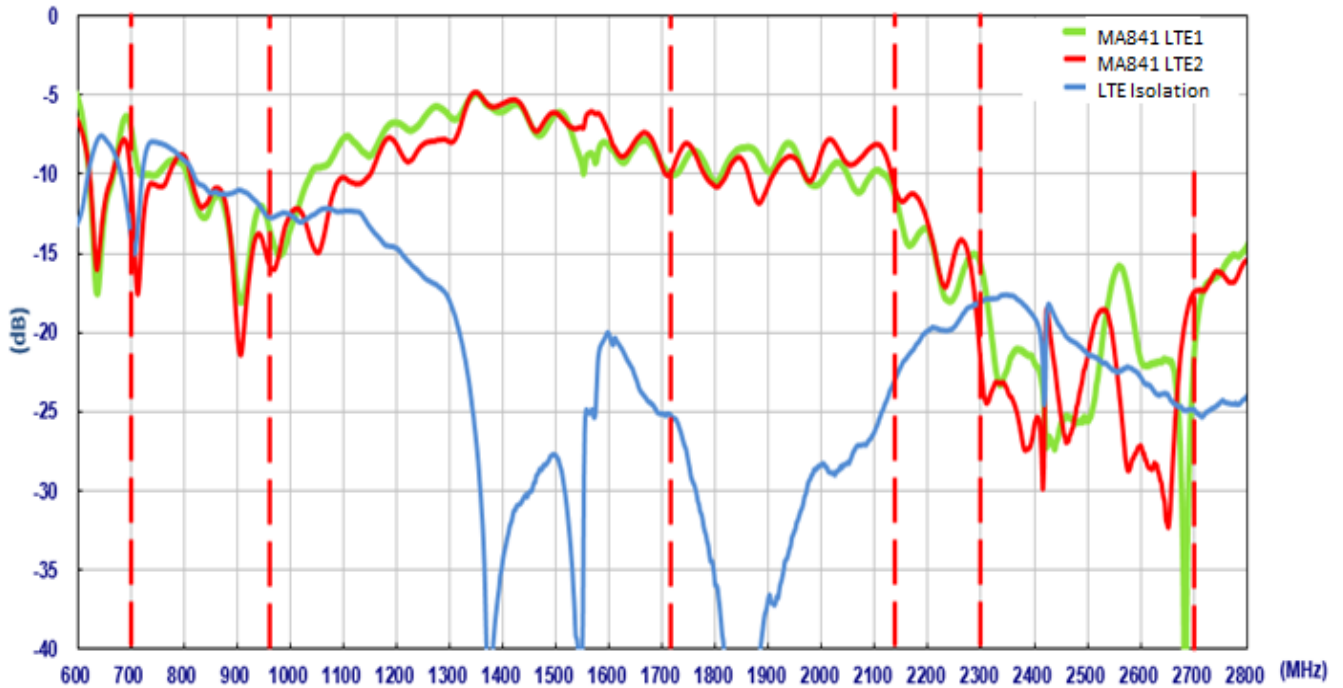

#### 3.2 Efficiency

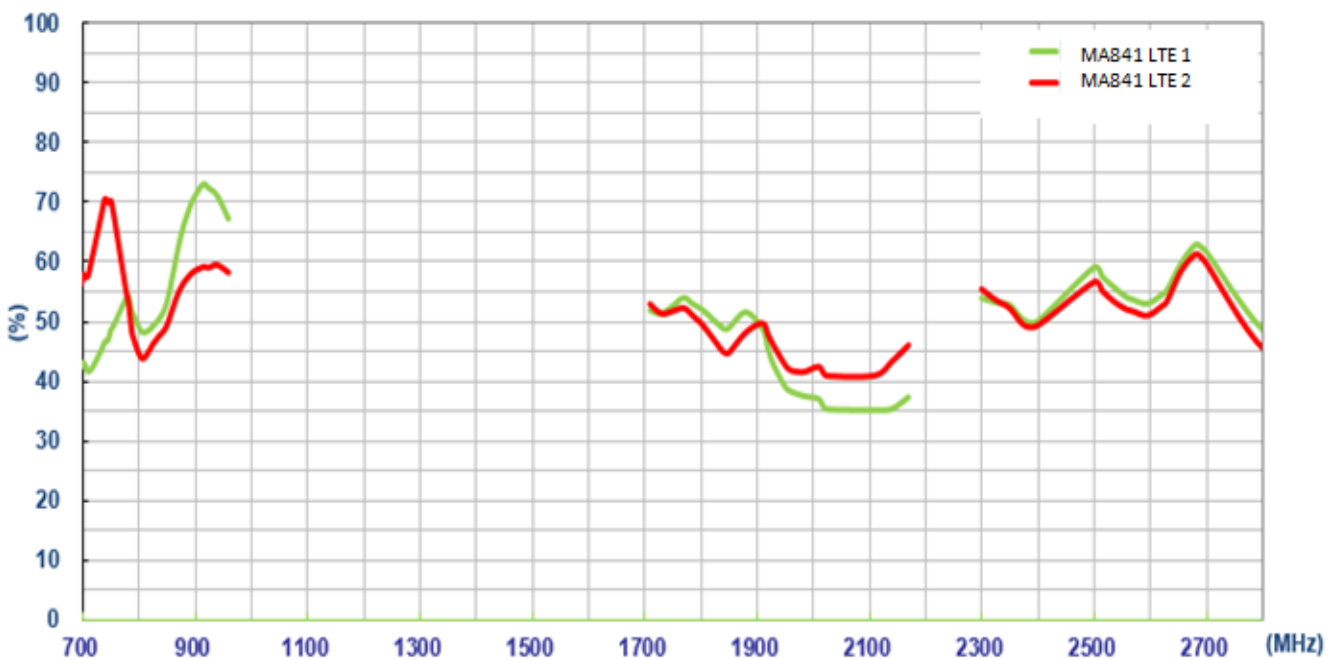

### 3.3 Average Gain

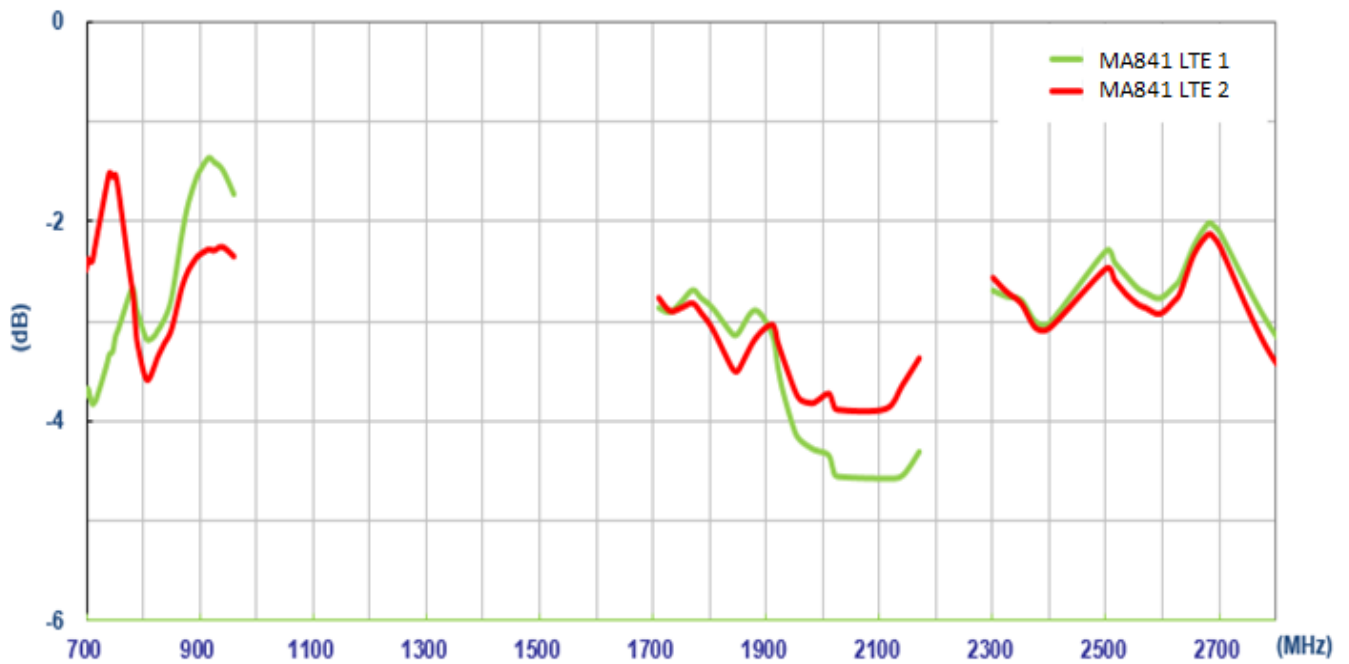

### 3.4 Peak Gain

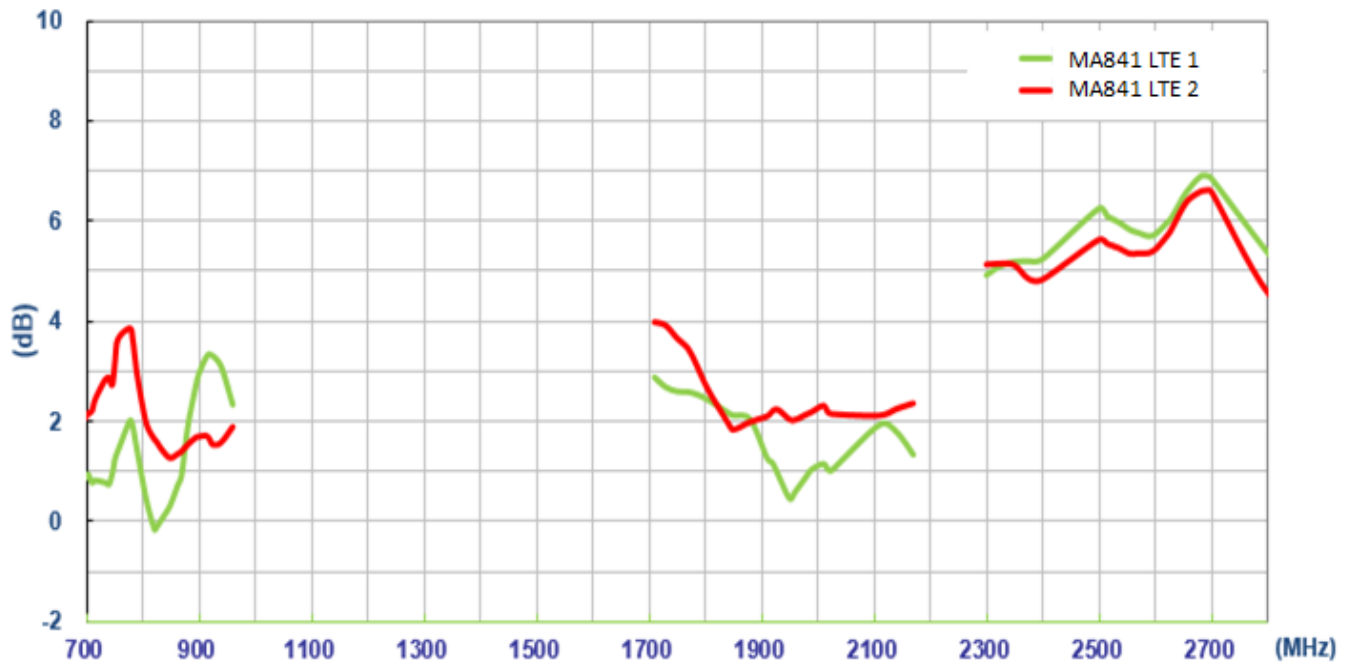

## 4. 2D Radiation Patterns

### 4.1 Test Setup

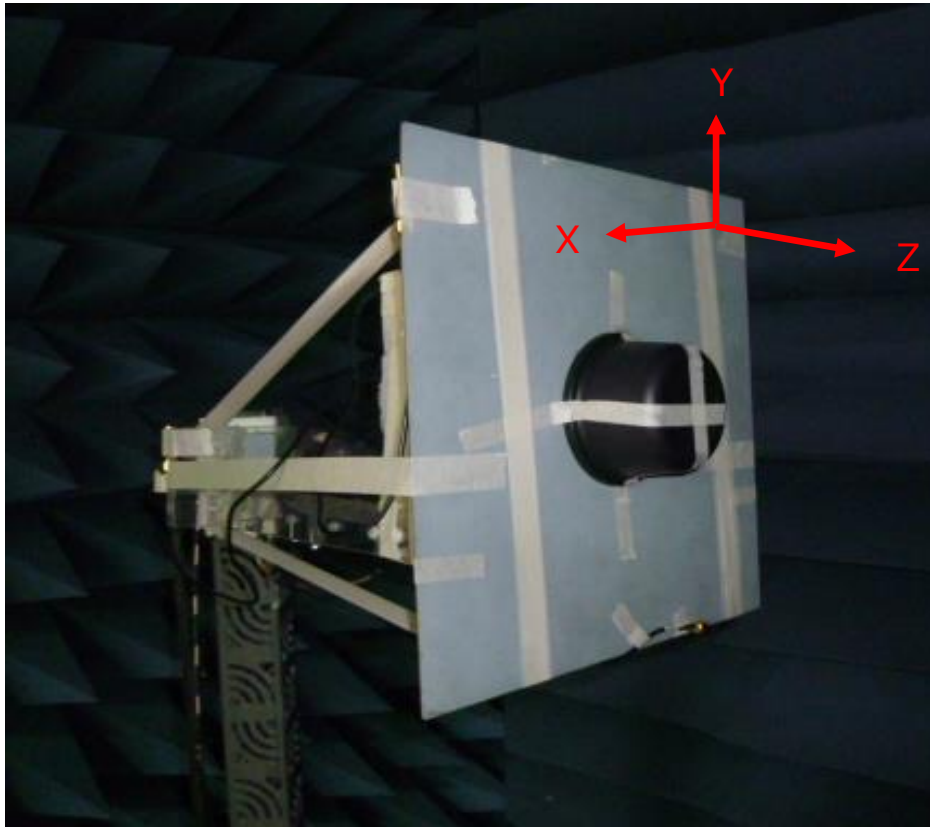

300 x 300mm Ground Plane



XY Plane

XZ Plane

YZ Plane

704MHz

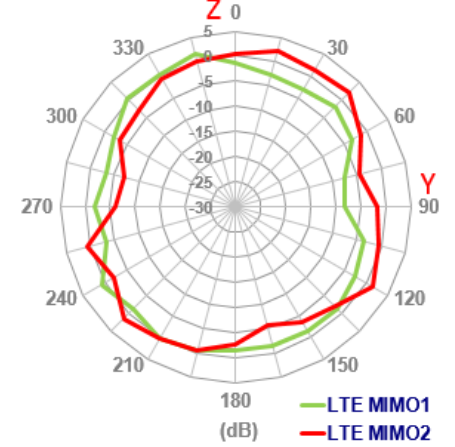
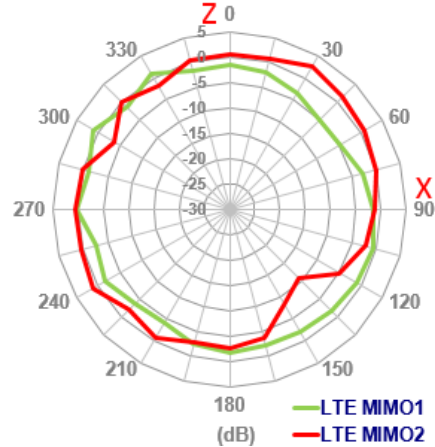
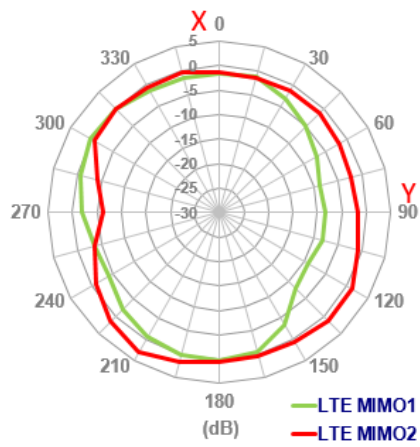

824MHz

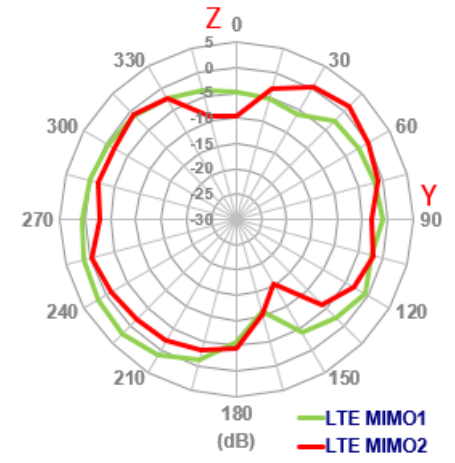
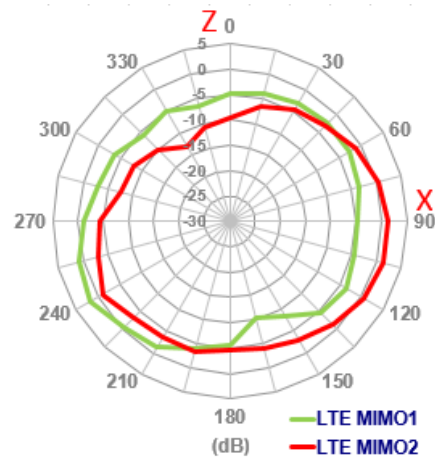
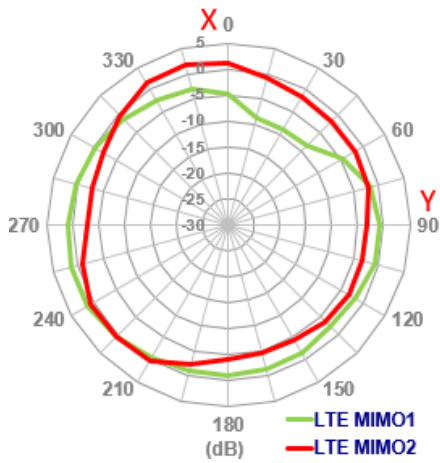

960MHz

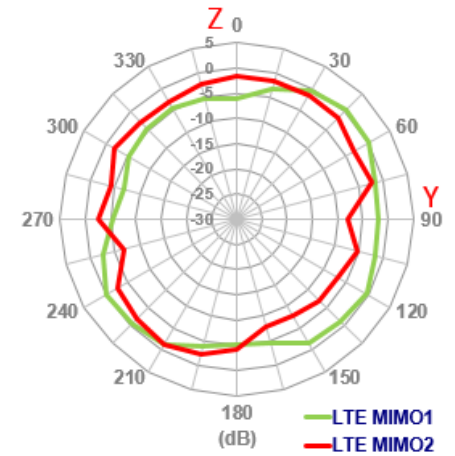
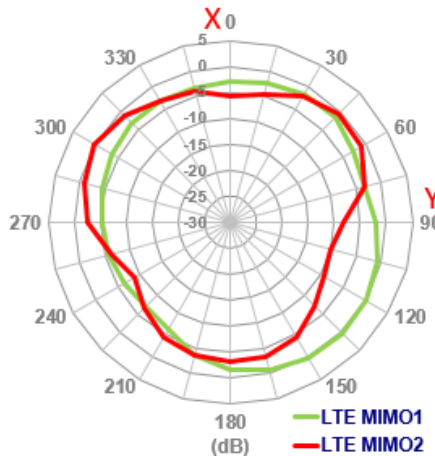
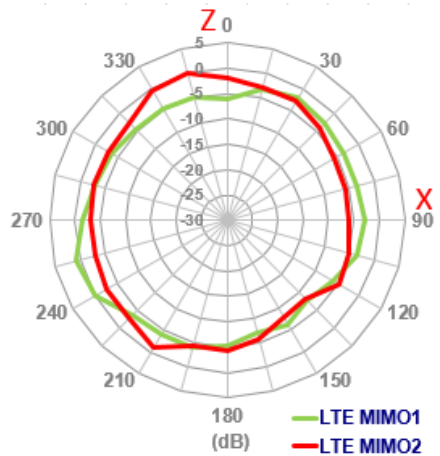



XY Plane

XZ Plane

YZ Plane

1710MHz

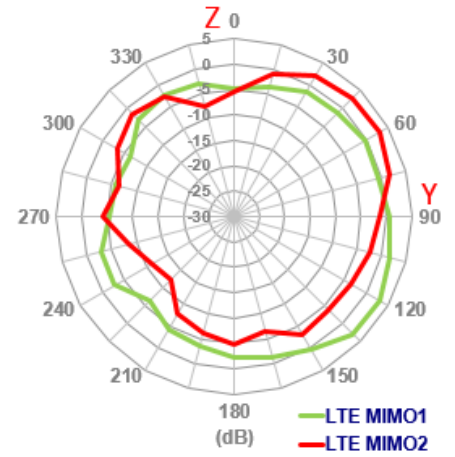
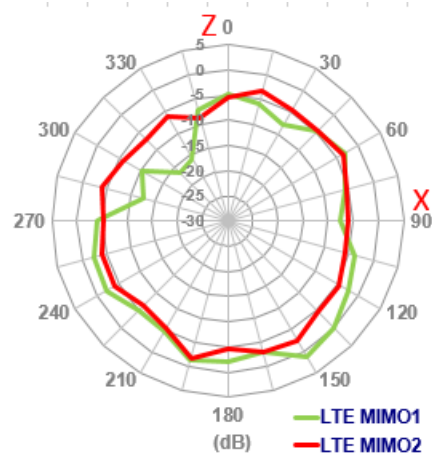
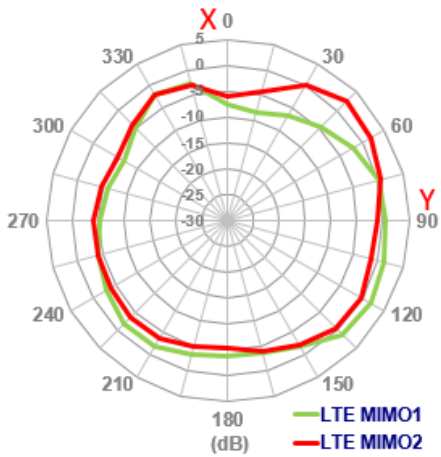

2170MHz

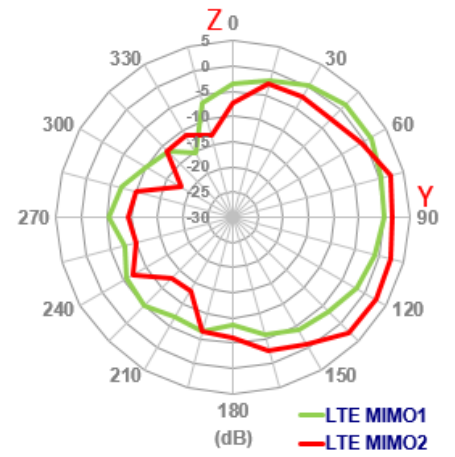
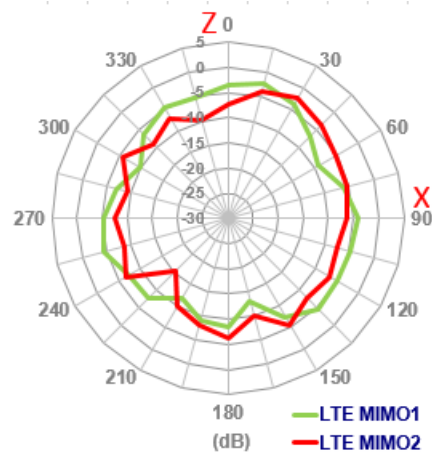
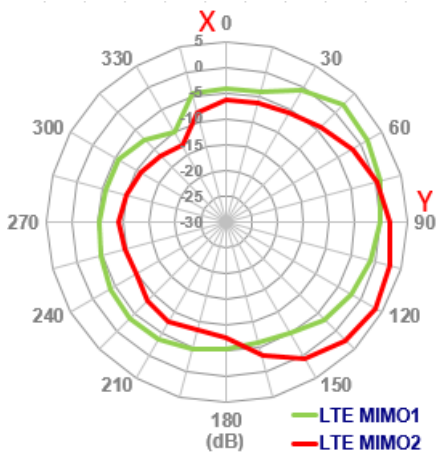

2300MHz

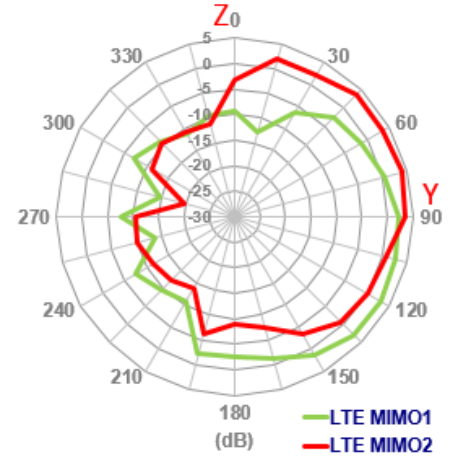
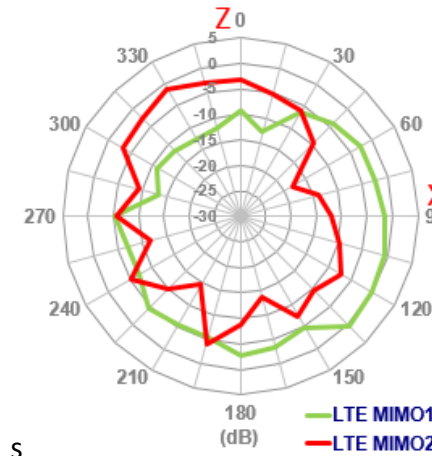
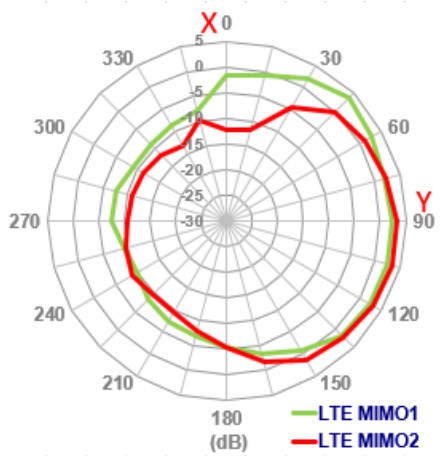

S

XY Plane

XZ Plane

YZ Plane

2700MHz

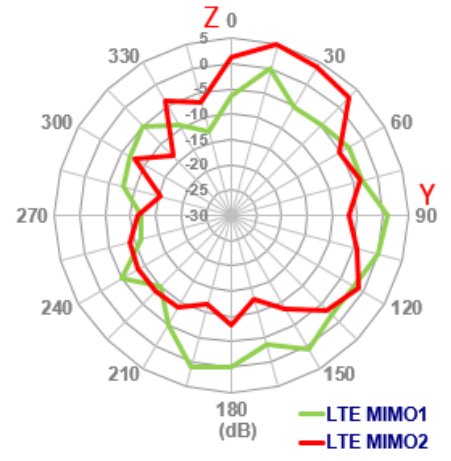
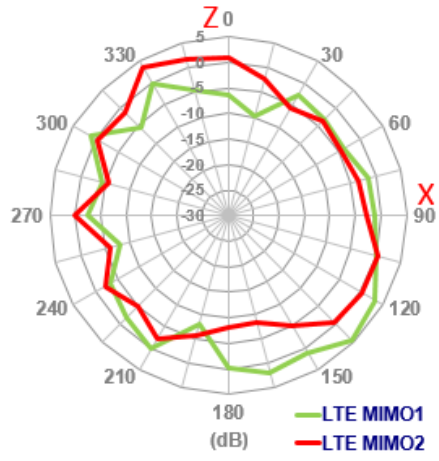
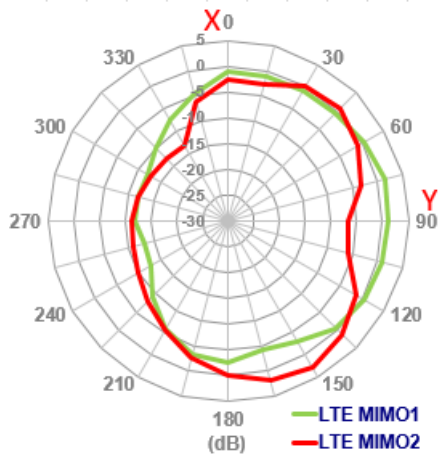

# 5. Mechanical Drawing (Units: mm)

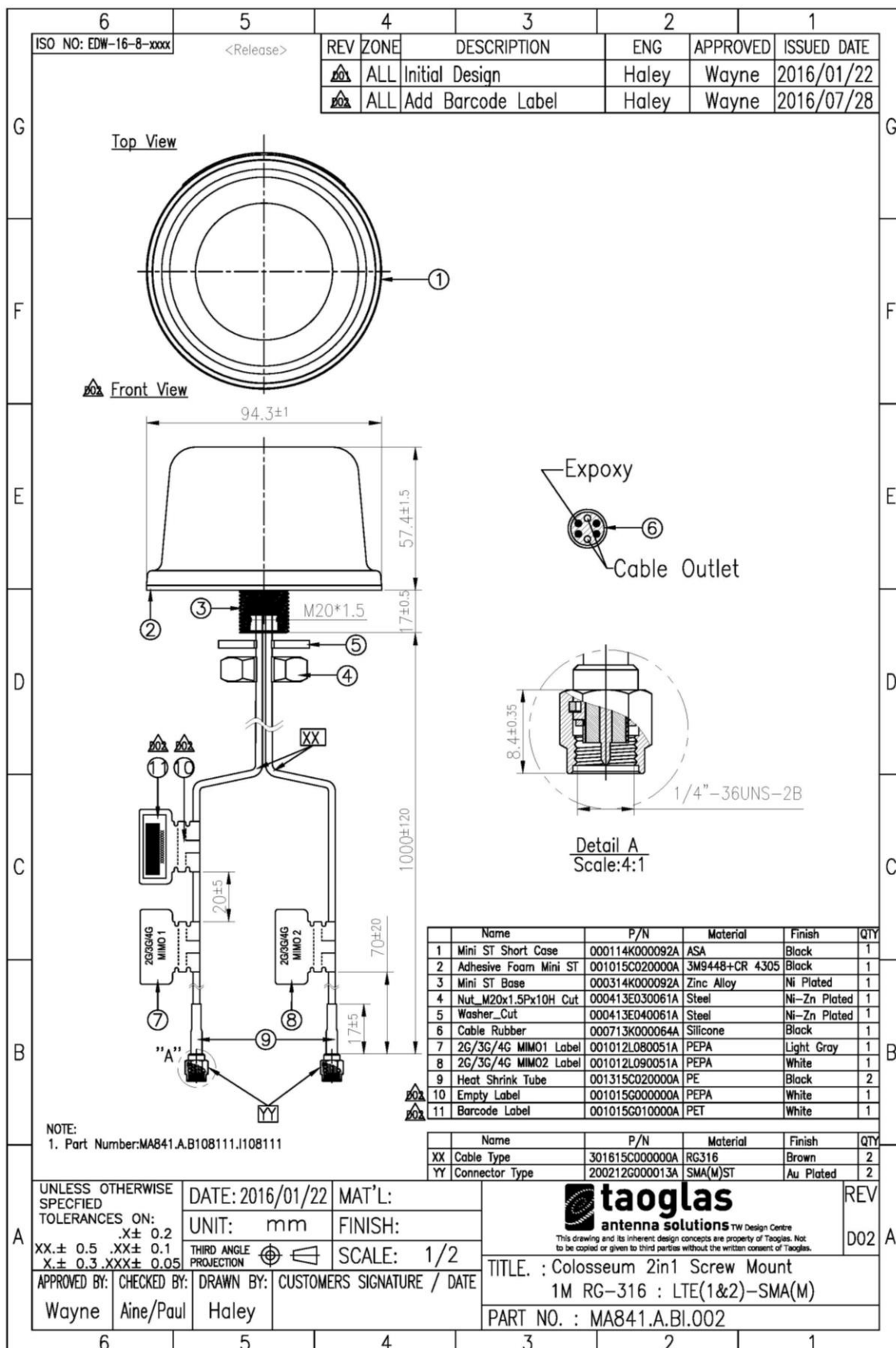

## 6. Packaging

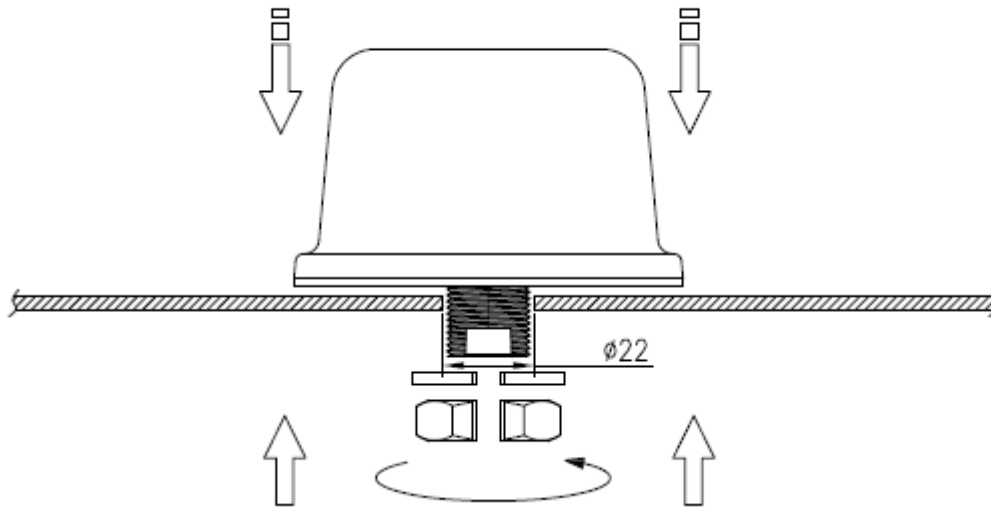

Recommended torque for mounting is 29.4N•m  
 Maximum torque for mounting is 39.2 N•m

## 7. Packaging

1 No. MA841.A.BI.002 per small box  
 Box Dimensions - 133 x 133 x 135mm  
 Weight - 350g

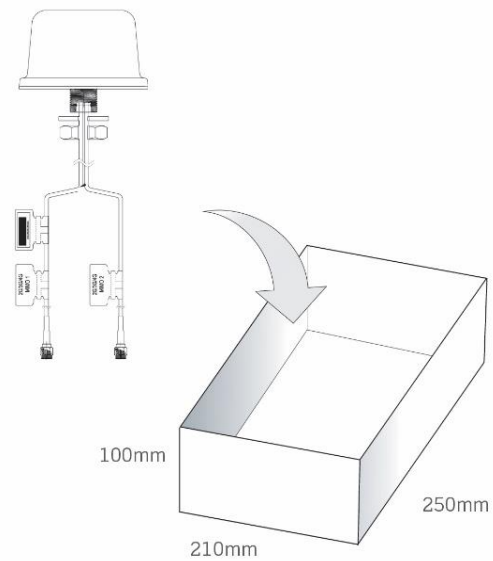

1 Outer Carton  
 Carton Dimensions - 590 x 310 x 140mm  
 8 pcs MA841.A.BI.002 per carton  
 Weight - 3.5Kg

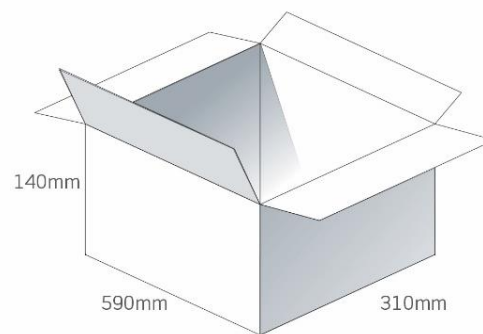

Pallet Dimensions 1200\*1000\*1460mm  
 54 Cartons per Pallet  
 9 Cartons per layer  
 6 Layers

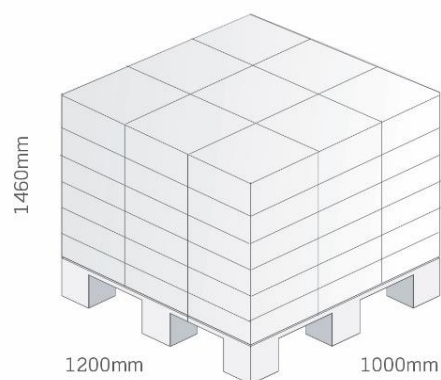

Changelog for the datasheet

**SPE-19-8-152 – MA841.A.BI.002**

**Revision: A (Original First Release)**

Date:	2019-12-09
Notes:	
Author:	Jack Conroy

**Previous Revisions**



**TAOGLAS**®

[www.taoglas.com](http://www.taoglas.com)





## X-ON Electronics

Largest Supplier of Electrical and Electronic Components

*Click to view similar products for [Antennas](#) category:*

*Click to view products by [Taoglas](#) manufacturer:*

Other Similar products are found below :

[GAN30084EU](#) [930-033-R](#) [GW17.07.0250E](#) [1513563-1](#) [EXE902SM](#) [APAMPG-117](#) [MAF94383](#) [W3908B0100](#) [W6102B0100](#) [YE572113-30RSMM](#) [108-00014-50](#) [66089-2406](#) [SPDA17RP918](#) [A09-F8NF-M](#) [A09-F5NF-M](#) [RGFRA1903041A1T](#) [W3593B0100](#) [W3921B0100](#) [SIMNA-868](#) [SIMNA-915](#) [SIMNA-433](#) [W1044](#) [W1049B090](#) [A75-001](#) [WTL2449CQ1-FRSMM](#) [CPL9C](#) [EXB148BN](#) [0600-00060](#) [TRA9020S3PBN-001](#) [GD5W-28P-NF](#) [MA9-7N](#) [GD53-25](#) [GD5W-21P-NF](#) [C37](#) [MAF94051](#) [MA9-5N](#) [EXD420PL](#) [B1322NR](#) [QWFTB120](#) [MAF94271](#) [MAF94300](#) [GPSMB301](#) [FG4403](#) [AO-AGSM-OM54](#) [5200232](#) [MIKROE-2349](#) [WCM.01.0111](#) [MIKROE-2393](#) [MIKROE-2352](#) [MIKROE-2350](#)