



TAOGLAS®



Datasheet

Low Profile 4G LTE SMD Dielectric Antenna

Part No:
PCS.26.A

Description:
Low Profile 4G LTE SMD Dielectric Antenna

Features:
High Efficiency 4G LTE SMD antenna
Covers 600-3000MHz
Band 71 Ready
Dimensions: 54.6*13*3mm
RoHS & Reach Compliant

1. Introduction	3
2. Specifications	4
3. Antenna Characteristics	6
4. Radiation Patterns	9
5. Mechanical Drawing	20
6. Antenna Intergration Guide	21
7. Packaging	30
8. Application Note	31
<hr/>	
Changelog	36

Taoglas makes no warranties based on the accuracy or completeness of the contents of this document and reserves the right to make changes to specifications and product descriptions at any time without notice. Taoglas reserves all rights to this document and the information contained herein. Reproduction, use or disclosure to third parties without express permission is strictly prohibited.



1. Introduction



The PCS.26.A is a low-profile SMD 4G/LTE embedded antenna designed for direct SMD mount on a device PCB. It provides high efficiency in a very small form factor, at 54.6*13*3mm. Its rectangular shape and very small size make it very easy to integrate. Packaged in tape and reel, it can be mounted via pick and place to reflow solder directly on the edge of the PCB board.

The antenna is a great match for lower cost cellular applications, particularly in the telematics and automotive sector, but also for IoT applications as it exhibits outstanding performance on variable ground plane lengths – meaning it can be used in small devices.

Typical Applications Include:

- IoT Sensors and devices
- Connected Health
- Wearables

This antenna is recommended for use with longer ground-plane lengths of 100mm or more for maximum efficiency. Some tuning can be performed on this antenna to help optimize to the device environment. Contact your regional Taoglas customer support team for further information.

2. Specifications

Electrical								
Frequency (MHz)	617-698	698-806	824-894	880-960	1710-1880	1850-1990	1920-2170	2300-2690
Peak Gain (dBi)	2.36	3.66	3.99	3.82	6.44	6.44	5.95	4.85
Average Gain (dB)	-1.85	-1.35	-1.14	-1.35	-1.22	-1.15	-1.49	-1.68
Efficiency (%)	65.9	73.3	76.9	73.4	75.6	76.8	70.9	68.5
Return Loss (dB)	<-7			<-7				<-6
Polarization	Linear							
Impedance	50 Ω							
Maximum Input Power	5W							
Mechanical								
Antenna Dimensions	54.6mm x 13mm x 3mm							
Material	FR4							
Soldering Type	SMD through Reflow							
Environmental								
Operation Temperature	-40°C ~ +85°C							
Storage Temperature	-40°C ~ +85°C							
Moisture Sensitivity Level (MSL)	3 (168 Hours)							

* All measurements were SMD on 178*55.6mm EVB board

5G/4G Bands			
Band Number	5G NR / FR1 / LTE / LTE-Advanced / WCDMA / HSPA / HSPA+ / TD-SCDMA		
	Uplink	Downlink	Covered
1	UL: 1920 to 1980	DL: 2110 to 2170	✓
2	UL: 1850 to 1910	DL: 1930 to 1990	✓
3	UL: 1710 to 1785	DL: 1805 to 1880	✓
4	UL: 1710 to 1755	DL: 2110 to 2155	✓
5	UL: 824 to 849	DL: 869 to 894	✓
7	UL: 2500 to 2570	DL: 2620 to 2690	✓
8	UL: 880 to 915	DL: 925 to 960	✓
9	UL: 1749.9 to 1784.9	DL: 1844.9 to 1879.9	✓
11	UL: 1427.9 to 1447.9	DL: 1475.9 to 1495.9	✗
12	UL: 699 to 716	DL: 729 to 746	✓
13	UL: 777 to 787	DL: 746 to 756	✓
14	UL: 788 to 798	DL: 758 to 768	✓
17	UL: 704 to 716	DL: 734 to 746	✓
18	UL: 815 to 830	DL: 860 to 875	✓
19	UL: 830 to 845	DL: 875 to 890	✓
20	UL: 832 to 862	DL: 791 to 821	✓
21	UL: 1447.9 to 1462.9	DL: 1495.9 to 1510.9	✗
22	UL: 3410 to 3490	DL: 3510 to 3590	✗
23	UL: 2000 to 2020	DL: 2180 to 2200	✓
24	UL: 1625.5 to 1660.5	DL: 1525 to 1559	✓
25	UL: 1850 to 1915	DL: 1930 to 1995	✓
26	UL: 814 to 849	DL: 859 to 894	✓
27	UL: 807 to 824	DL: 852 to 869	✓
28	UL: 703 to 748	DL: 758 to 803	✓
29	UL: -	DL: 717 to 728	✓
30	UL: 2305 to 2315	DL: 2350 to 2360	✓
31	UL: 452.5 to 457.5	DL: 462.5 to 467.5	✗
32	UL: -	DL: 1452 - 1496	✗
35		1850 to 1910	✓
38		2570 to 2620	✓
39		1880 to 1920	✓
40		2300 to 2400	✓
41		2496 to 2690	✓
42		3400 to 3600	✗
43		3600 to 3800	✗
48		3550 to 3700	✗
66	UL: 1710-1780	DL: 2110-2200	✓
71		617 to 698	✓
74/75/76		1427 to 1518	✓
78		3300 to 3800	✗
79		4400 to 5000	✗
85	698-716	728-746	✓

3. Antenna Characteristics

3.1 Return Loss

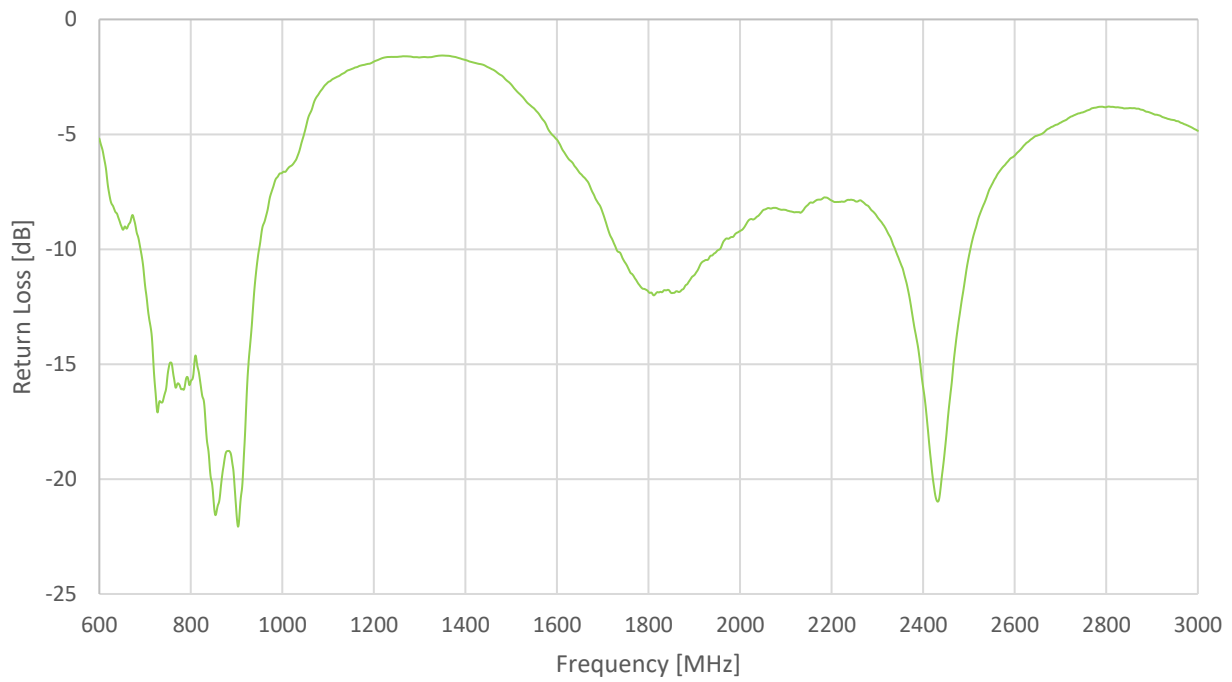

3.2 VSWR

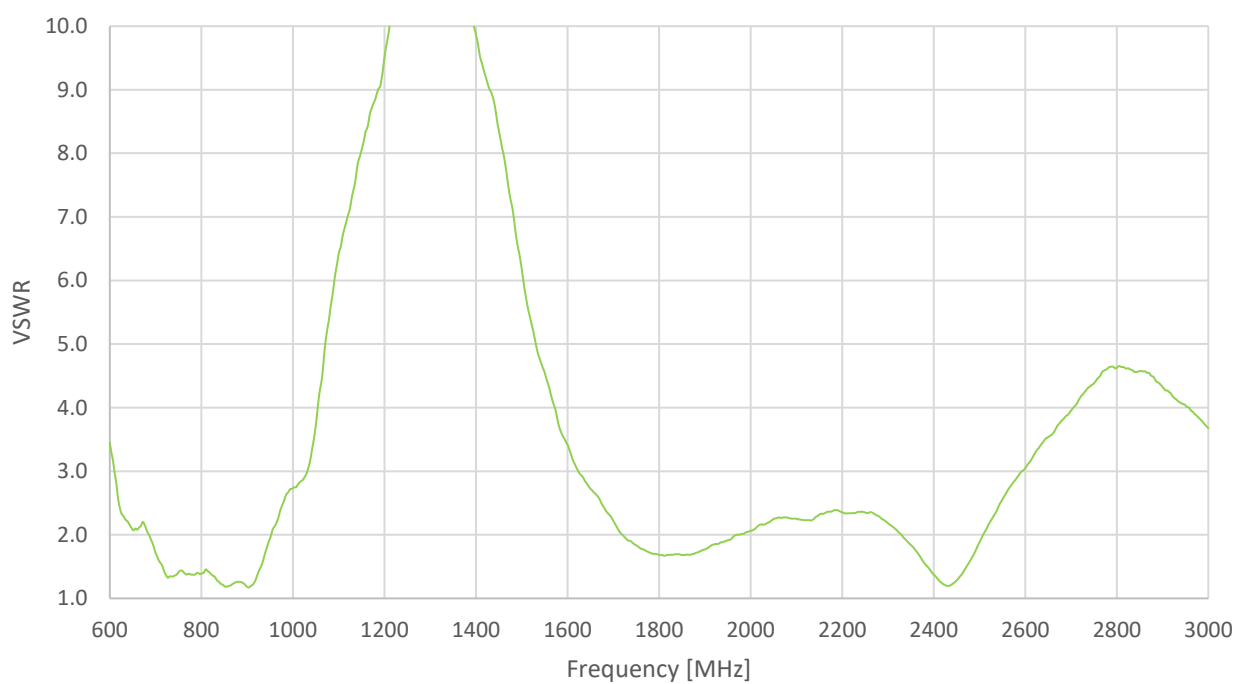

3.3 Efficiency

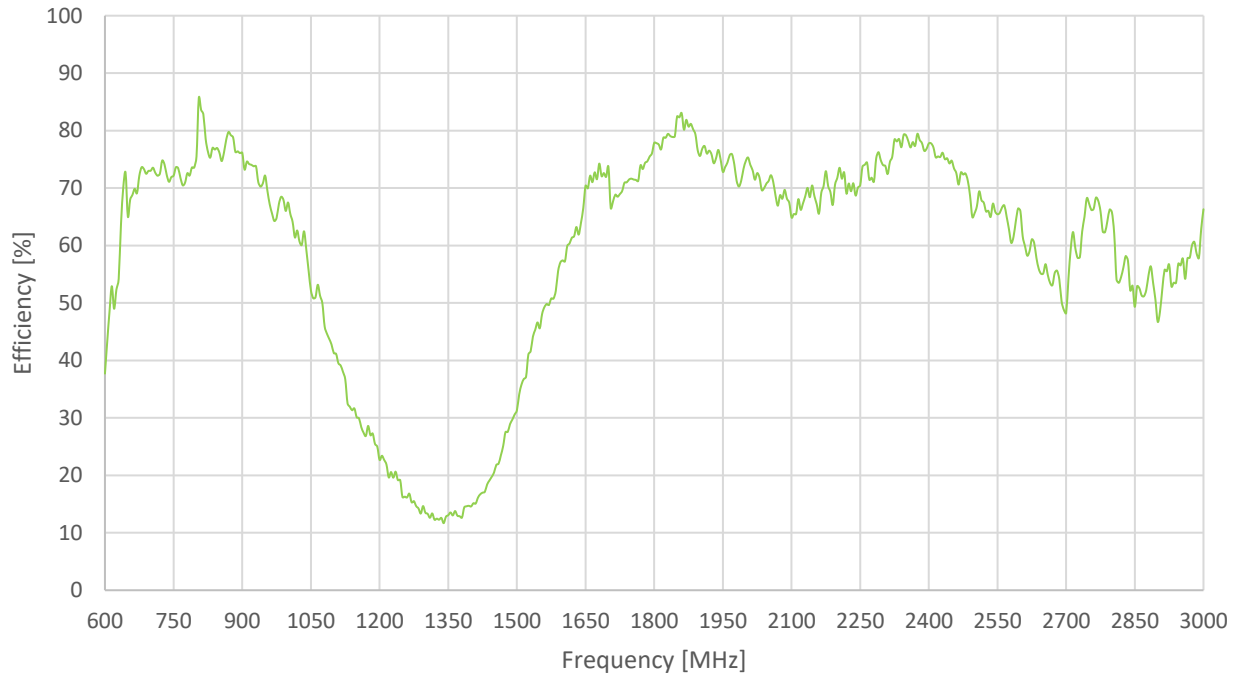

3.4 Average Gain

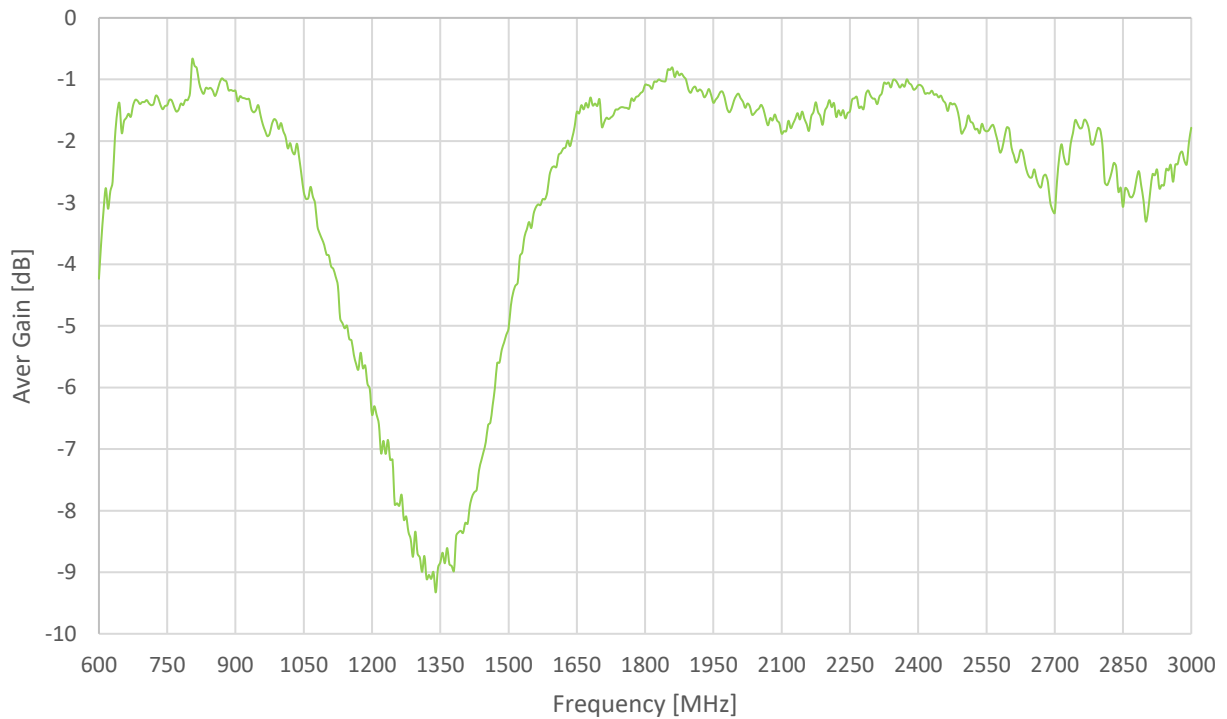

3.5 Peak Gain

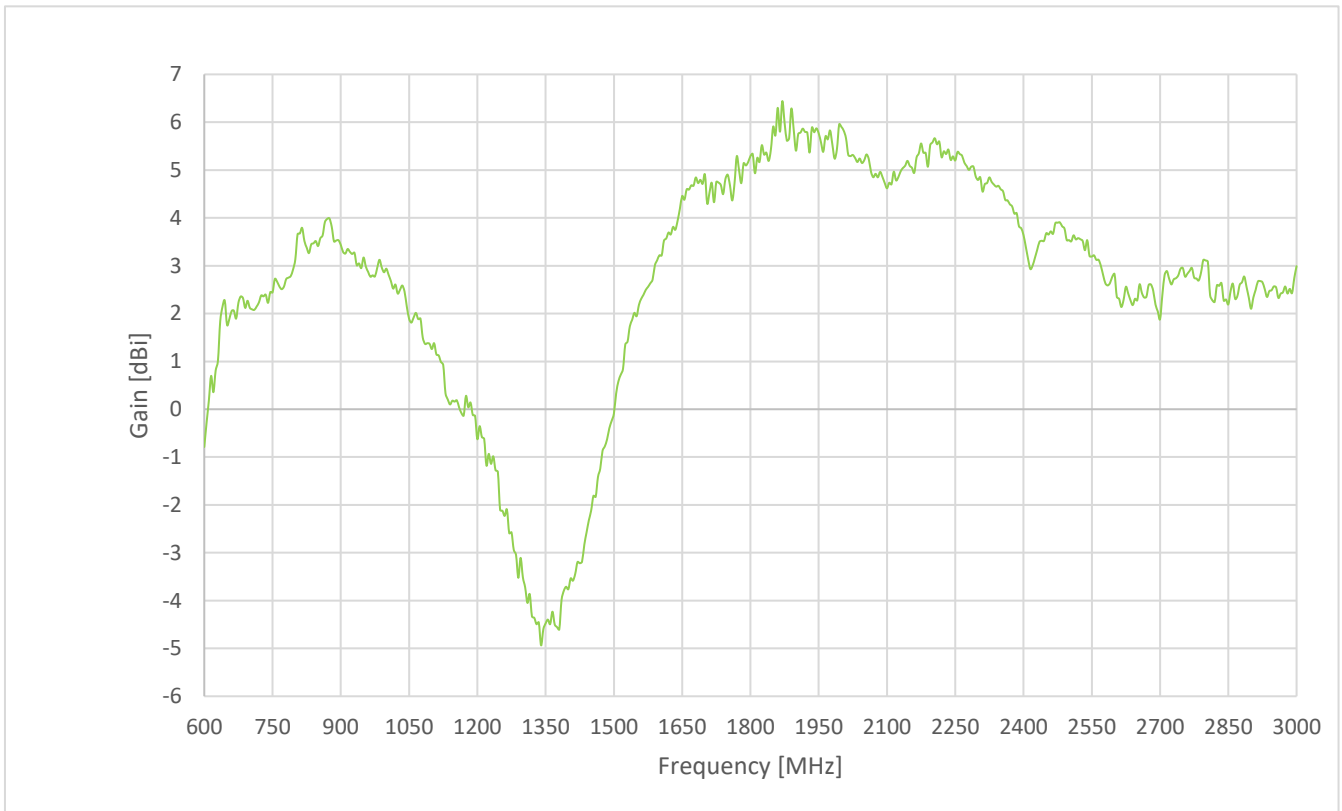

4. Radiation Patterns

4.1 Test Setup

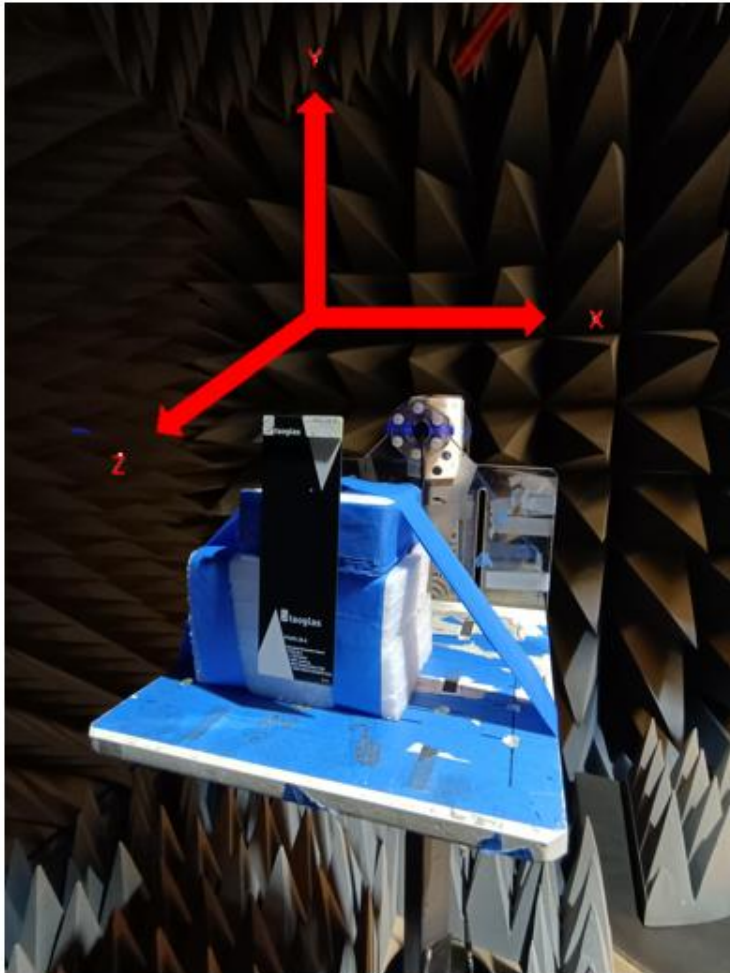

Chamber Setup

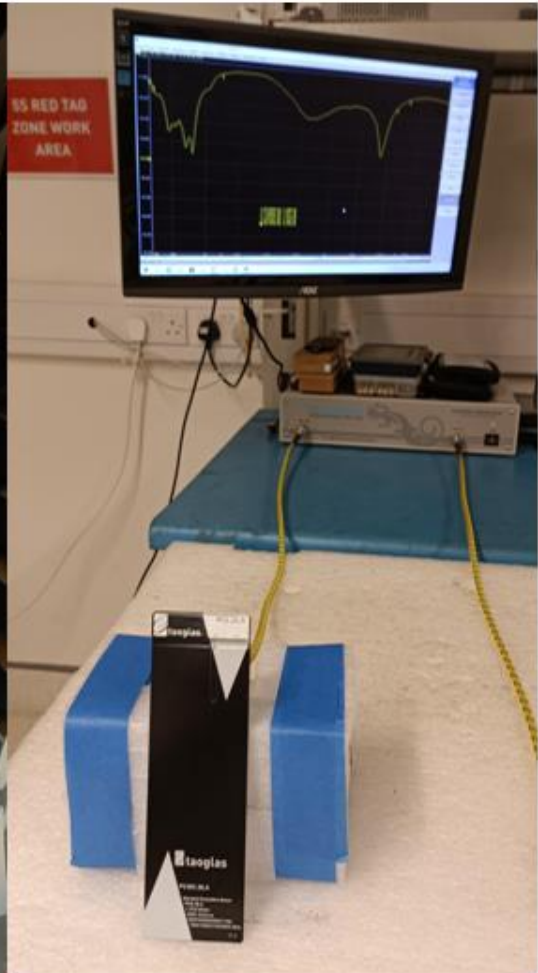

VNA Setup

4.2 615MHz 3D and 2D Radiation Patterns

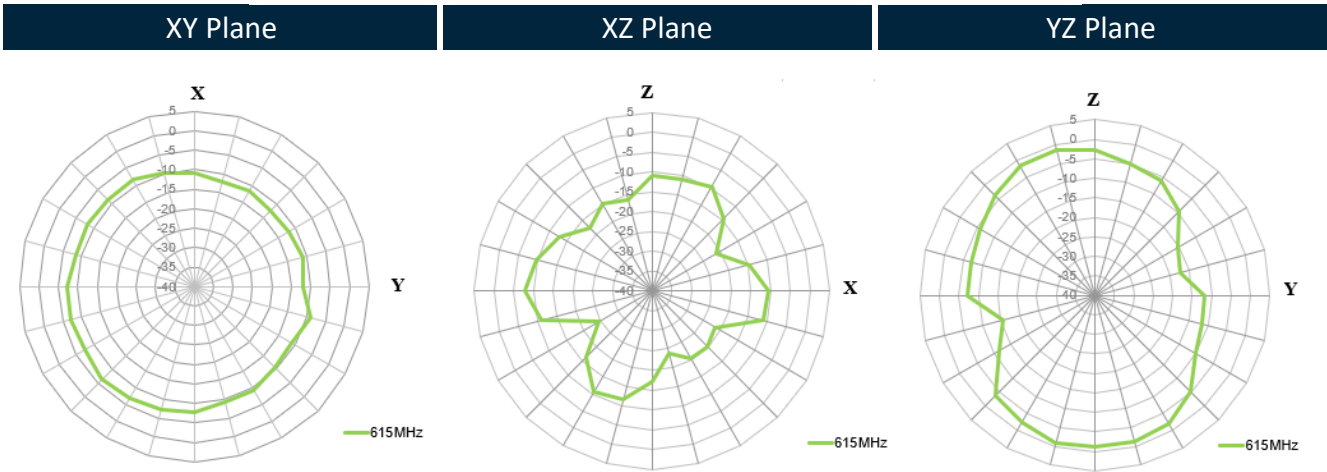
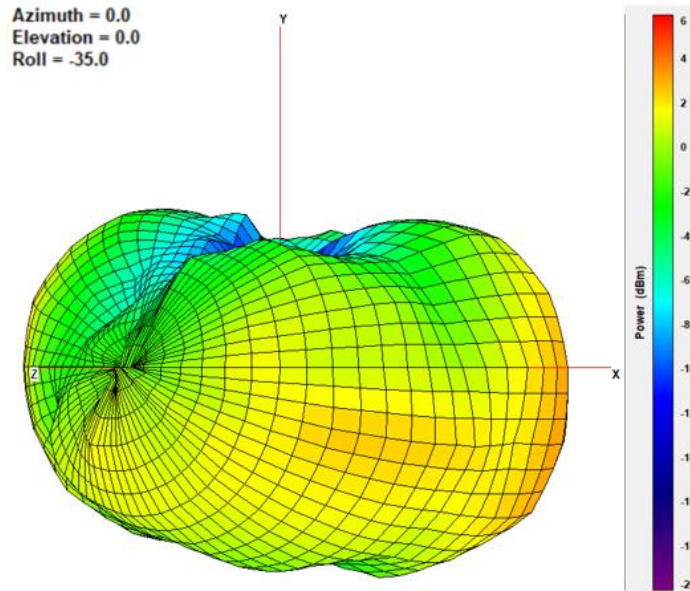

705MHz

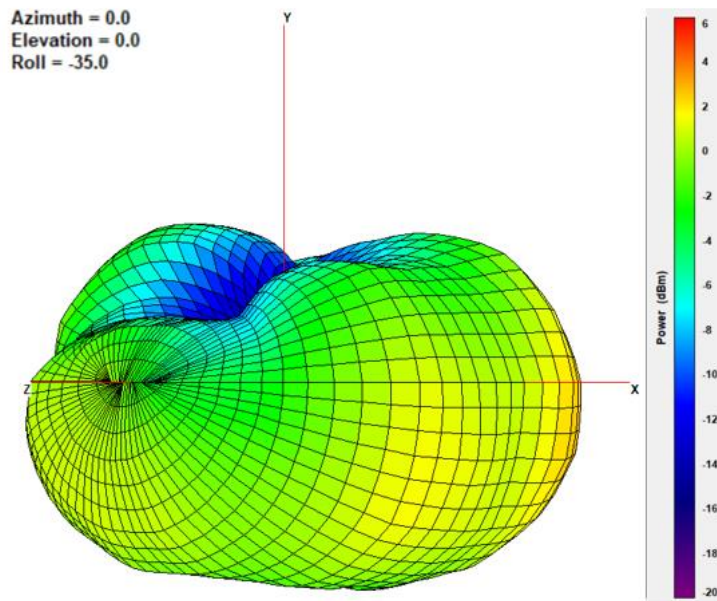

XY Plane

XZ Plane

YZ Plane

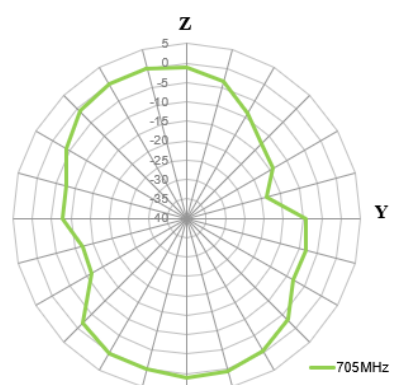
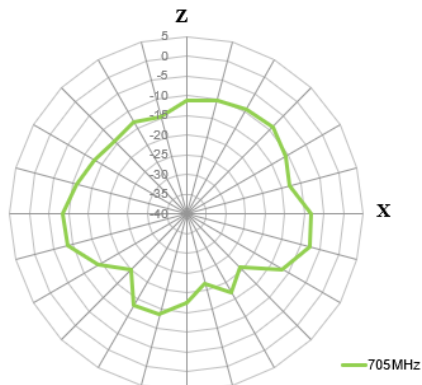
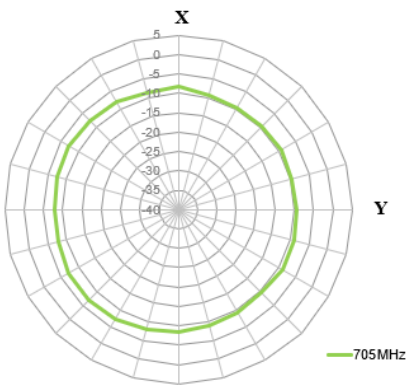

825MHz

Azimuth = 0.0
Elevation = 0.0
Roll = -35.0

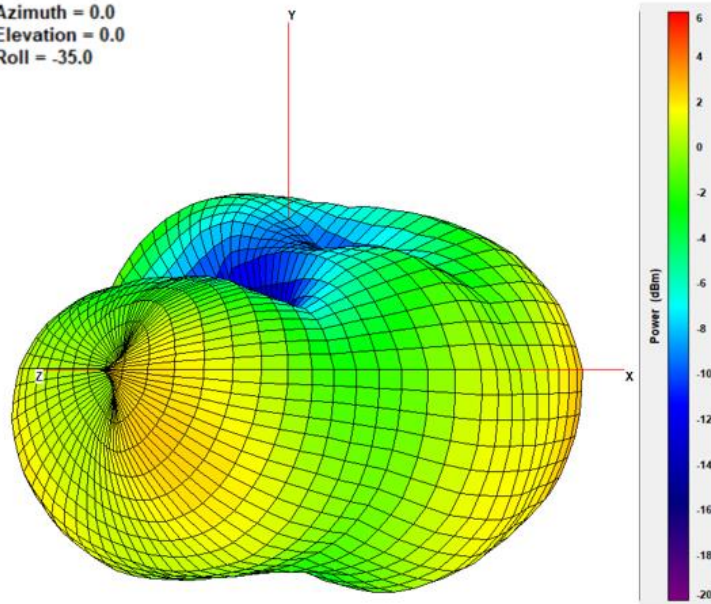

XY Plane

XZ Plane

YZ Plane

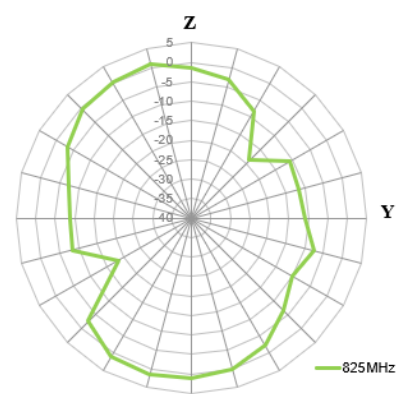
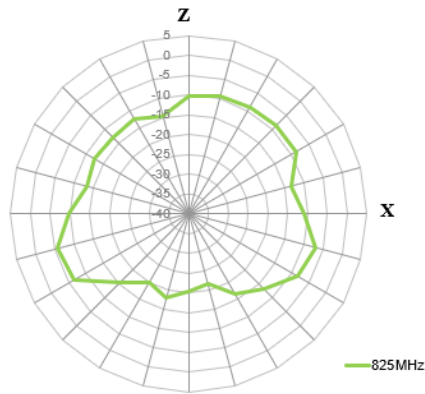
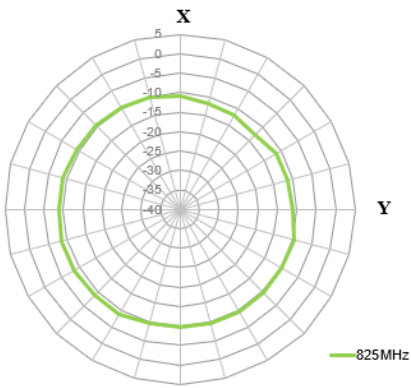

960MHz

Azimuth = 0.0
Elevation = 0.0
Roll = -35.0

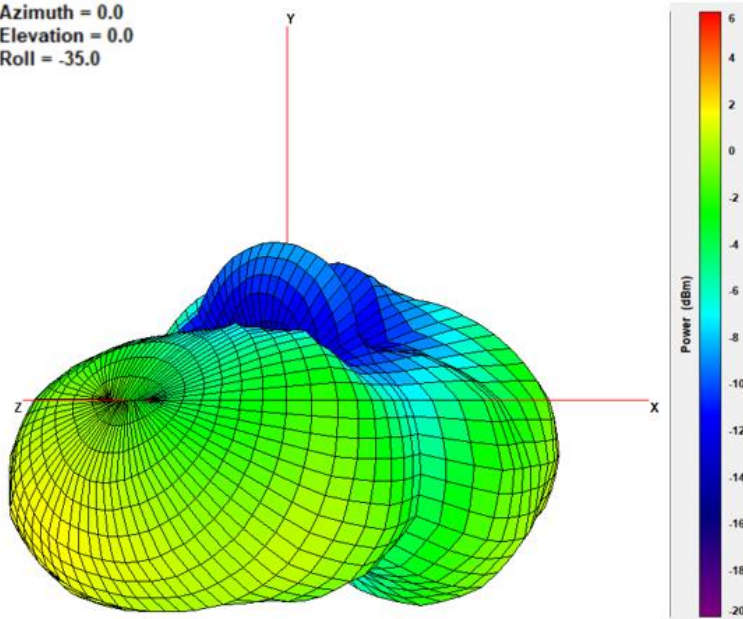

XY Plane

XZ Plane

YZ Plane

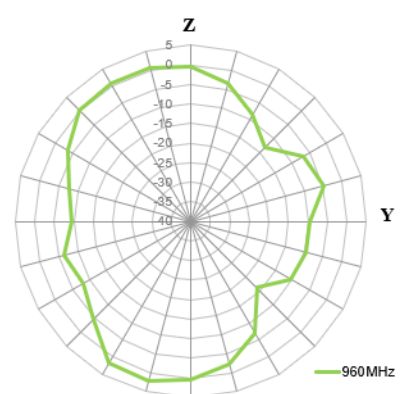
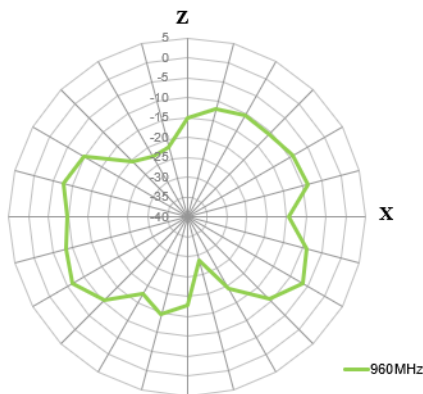
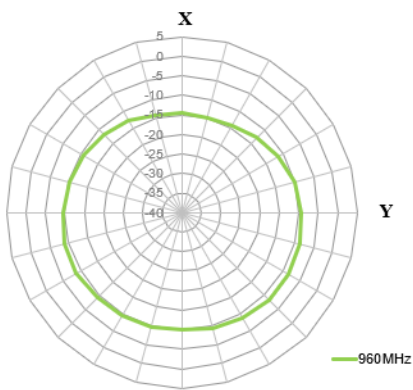

1710MHz

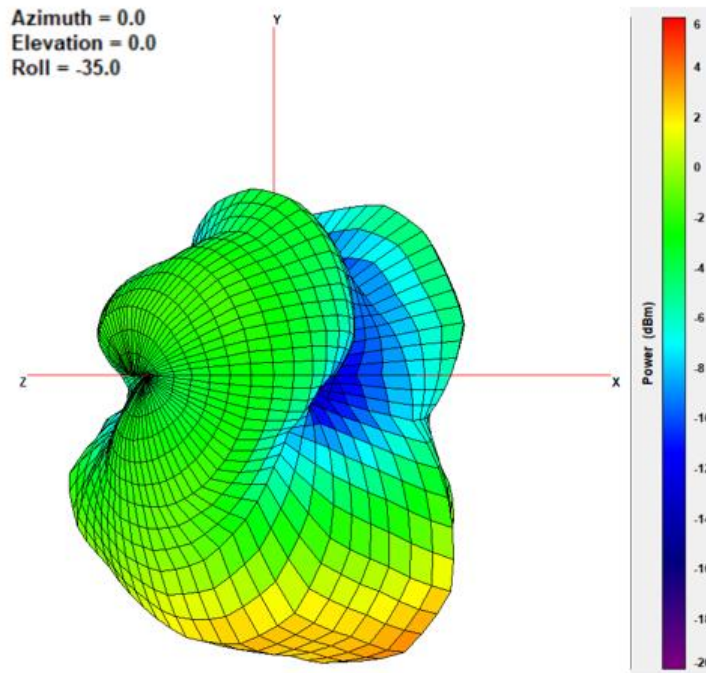

XY Plane

XZ Plane

YZ Plane

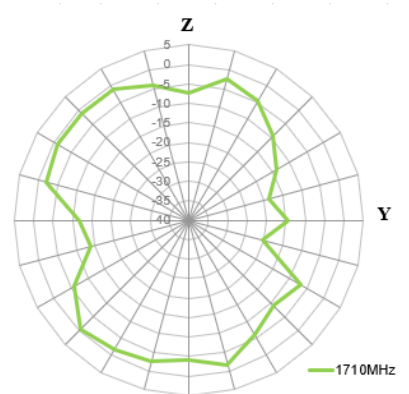
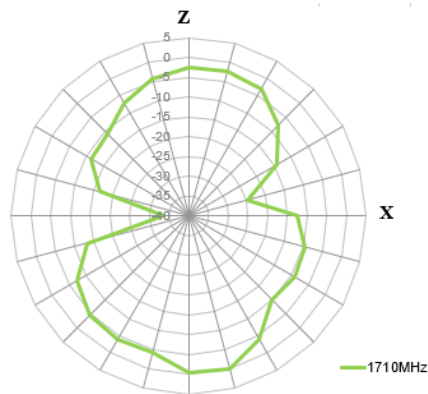
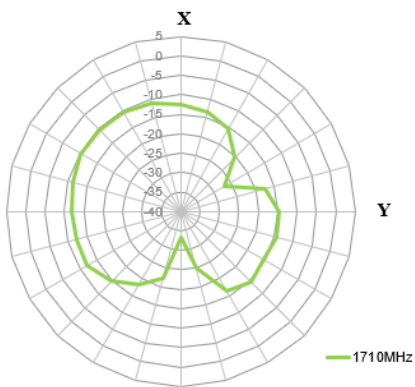

1850MHz

Azimuth = 0.0
Elevation = 0.0
Roll = -35.0

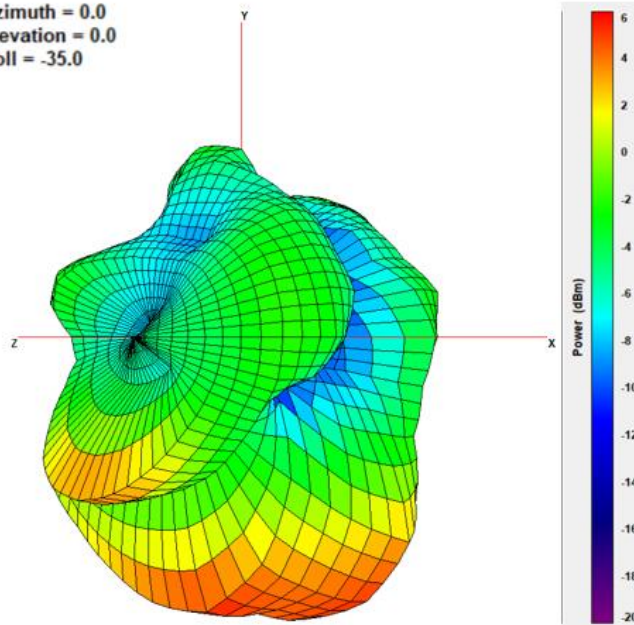

XY Plane

XZ Plane

YZ Plane

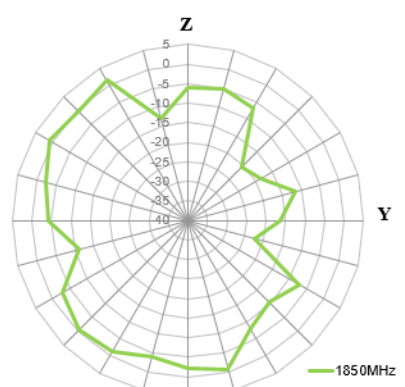
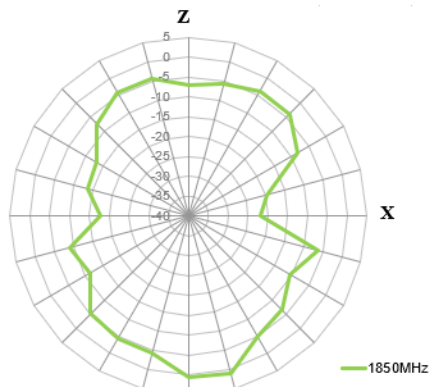
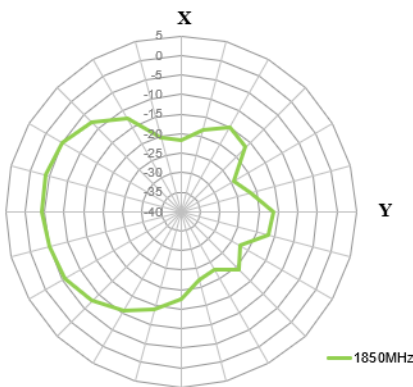

1990MHz

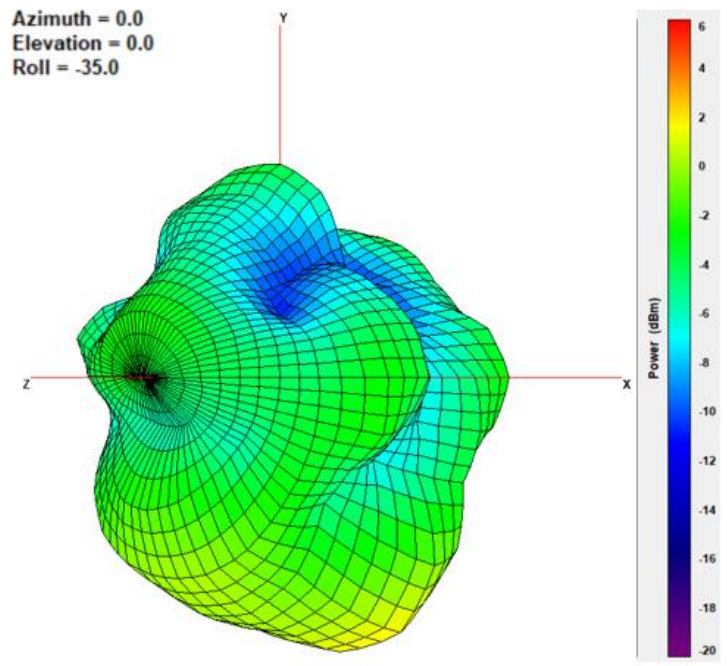

XY Plane

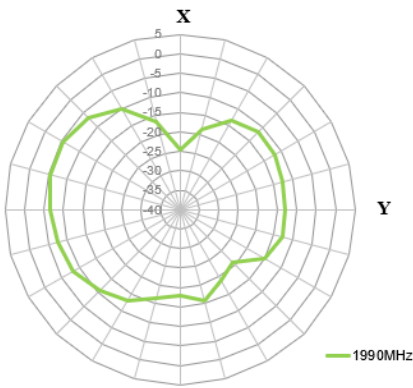

XZ Plane

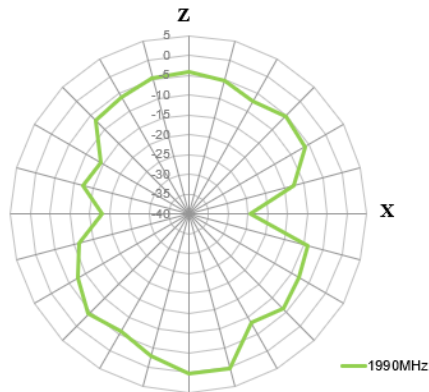

YZ Plane

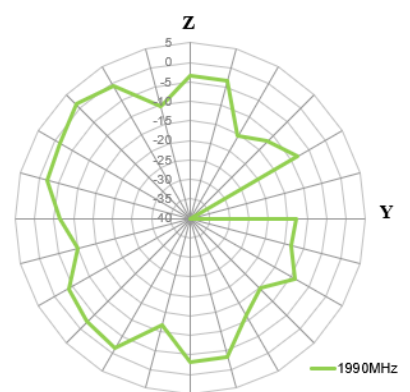

2170MHz

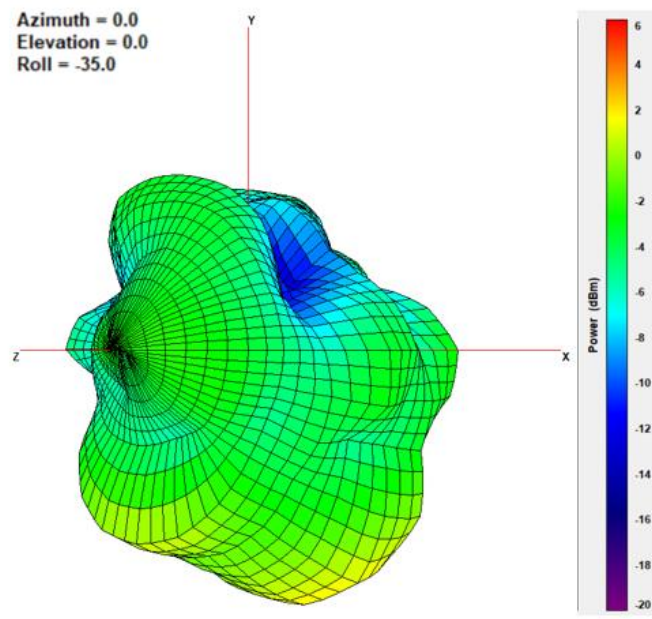

XY Plane

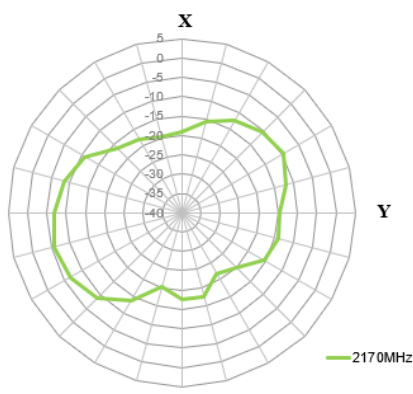

XZ Plane

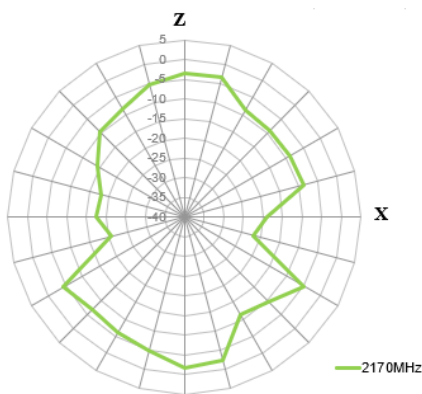

YZ Plane

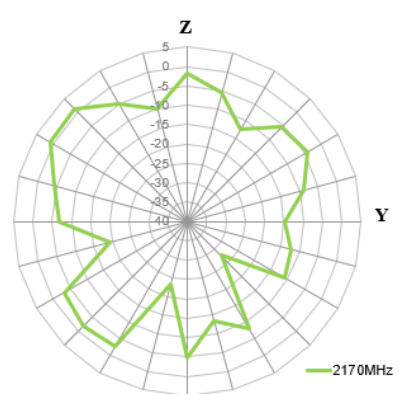

2500MHz

Azimuth = 0.0
Elevation = 0.0
Roll = -35.0

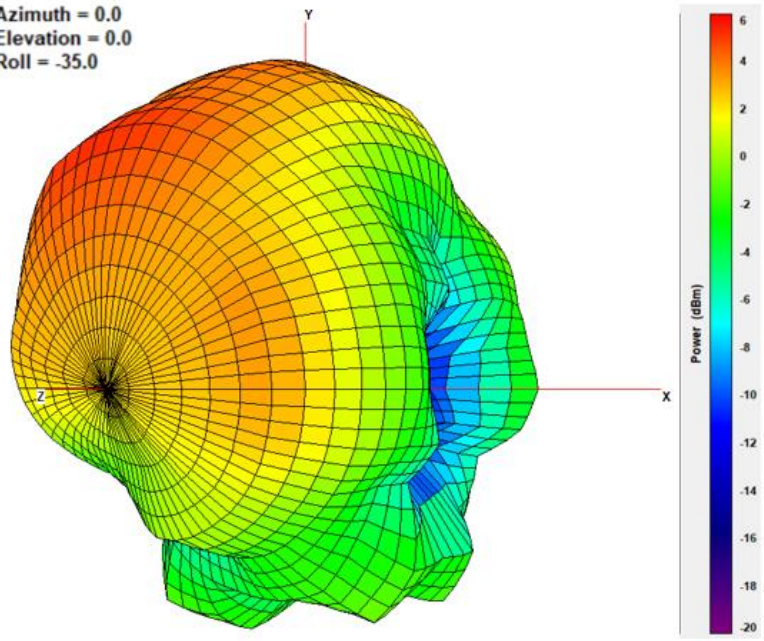

XY Plane

XZ Plane

YZ Plane

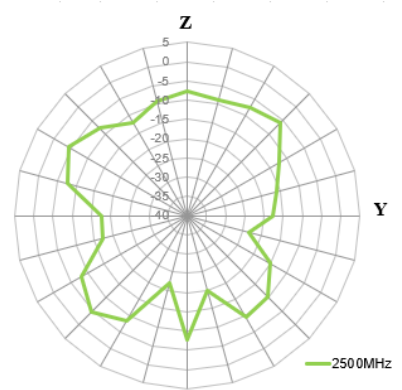
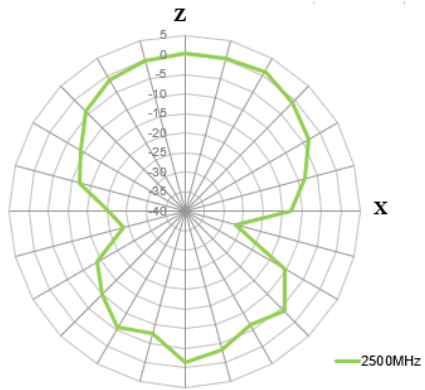
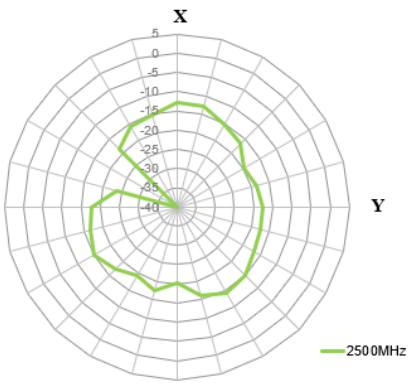

2690MHz

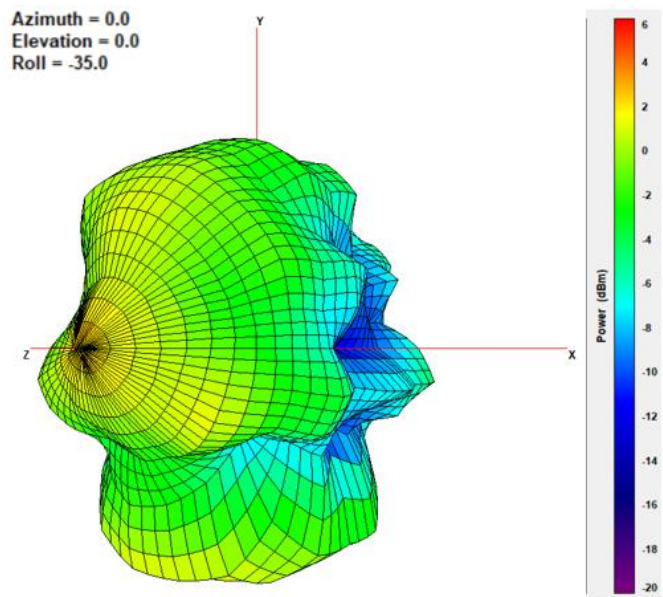

XY Plane

XZ Plane

YZ Plane

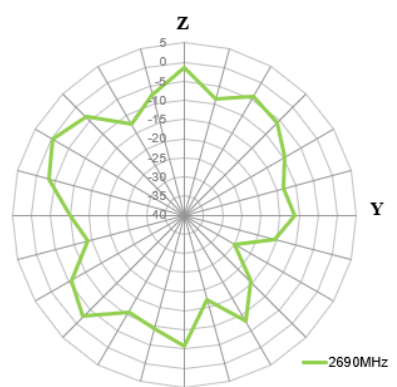
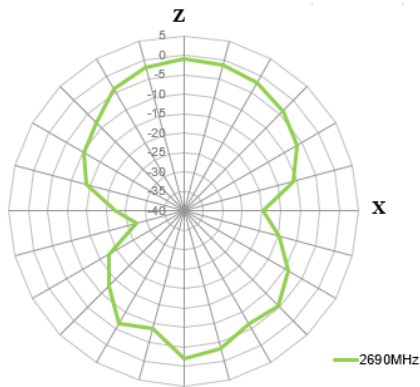
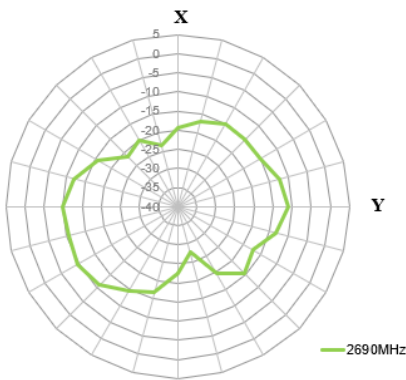

5. Mechanical Drawing (Units: mm)

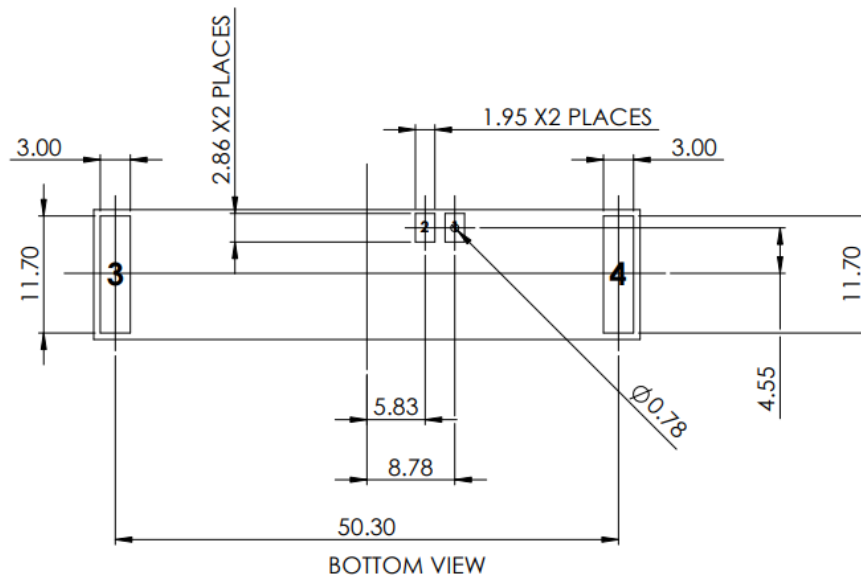
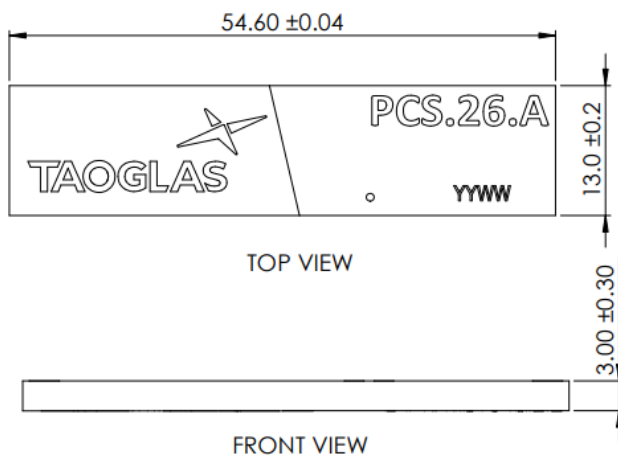
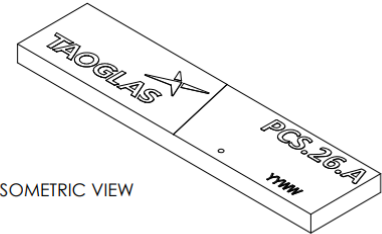

6. Antenna Integration Guide

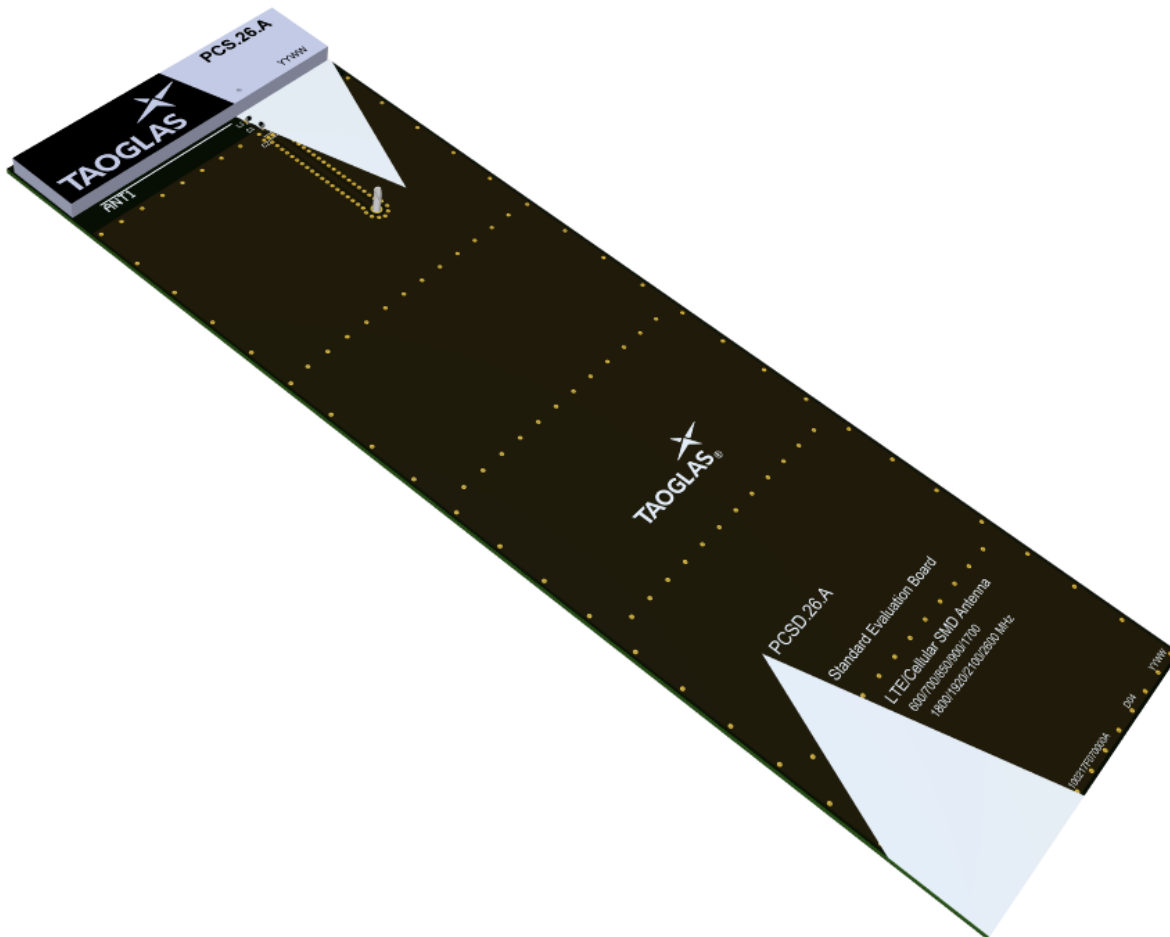
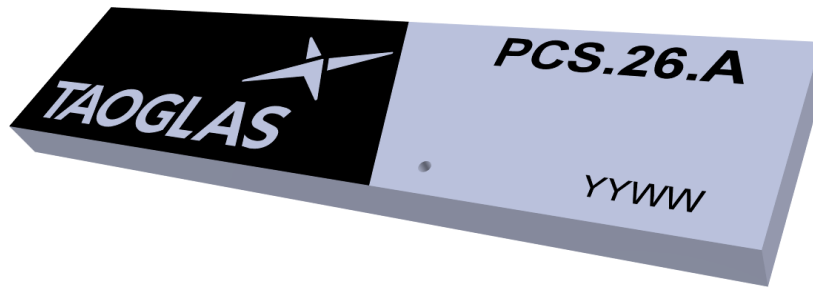

6.1 Schematic Symbol and Pin Definition

The circuit symbol for the antenna is shown below. The antenna has 4 pins with only two pins (Pin 1 and Pin 2) as functional. Pins 3 and 4 are for mechanical strength.

Pin	Description
1	RF Feed
2	Ground
3, 4	Mechanical, Not Connected

PCS.26.A
ANT1

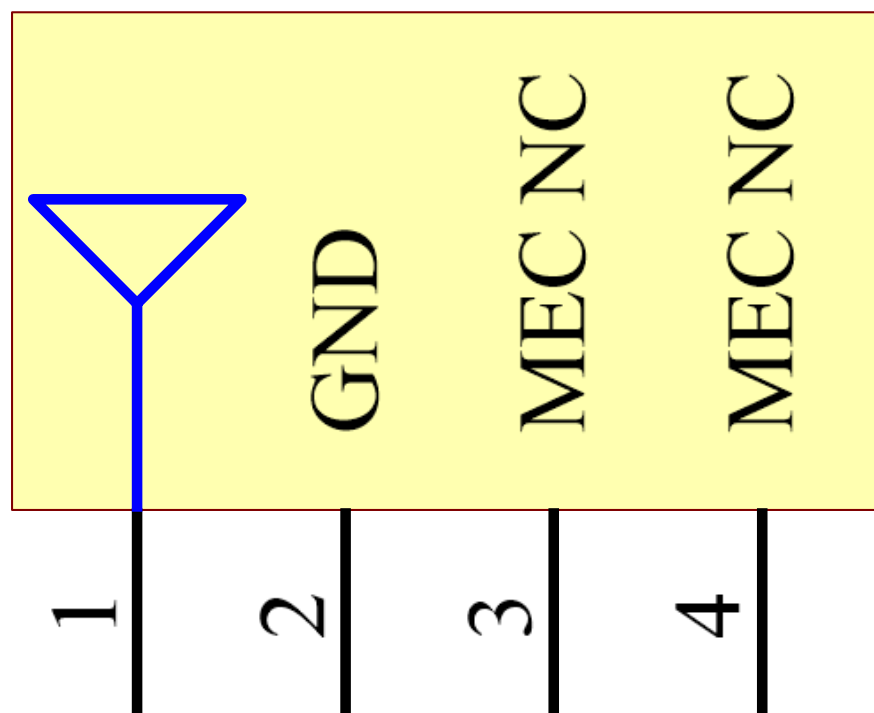

6.2 Antenna Integration

Whatever the size of the PCB, the antenna should ideally be placed on the PCB's shortest side, to take advantage of the ground plane. Optimized matching components can be placed as shown.

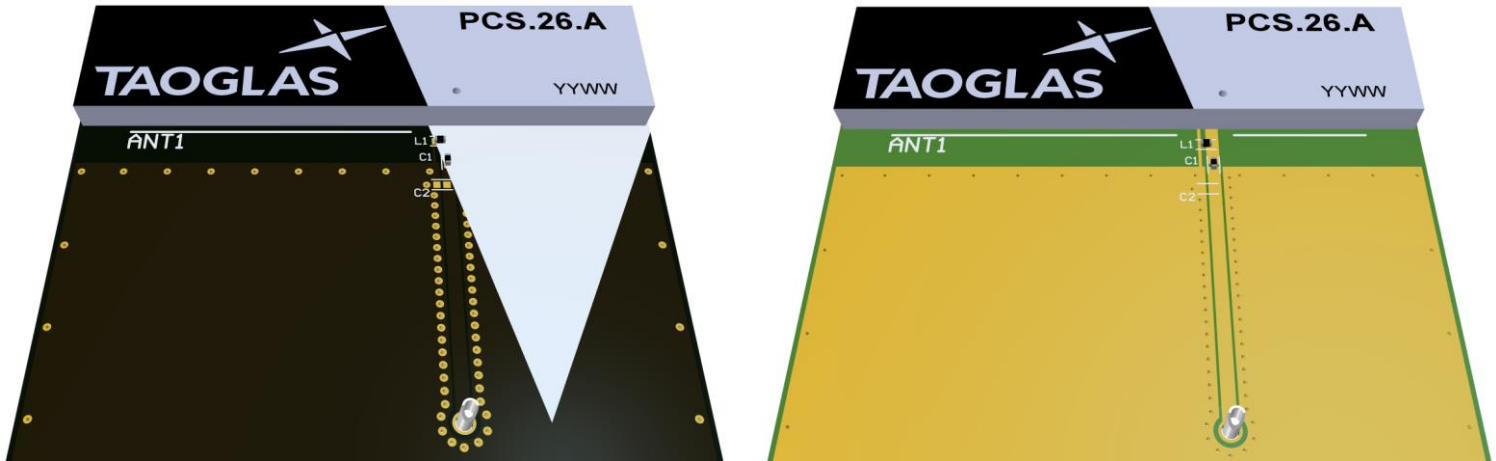

6.3 PCB Layout

The footprint and clearance on the PCB must meet the antenna specification. An example of the PCB layout shows the antenna footprint with clearance. Note the placement of the optimized components. L1 is positioned outside the ground plane and C1 is sitting across the ground plane and the copper clearance area. C2 is optional as a component but it is recommended to include these pads in case they are needed.

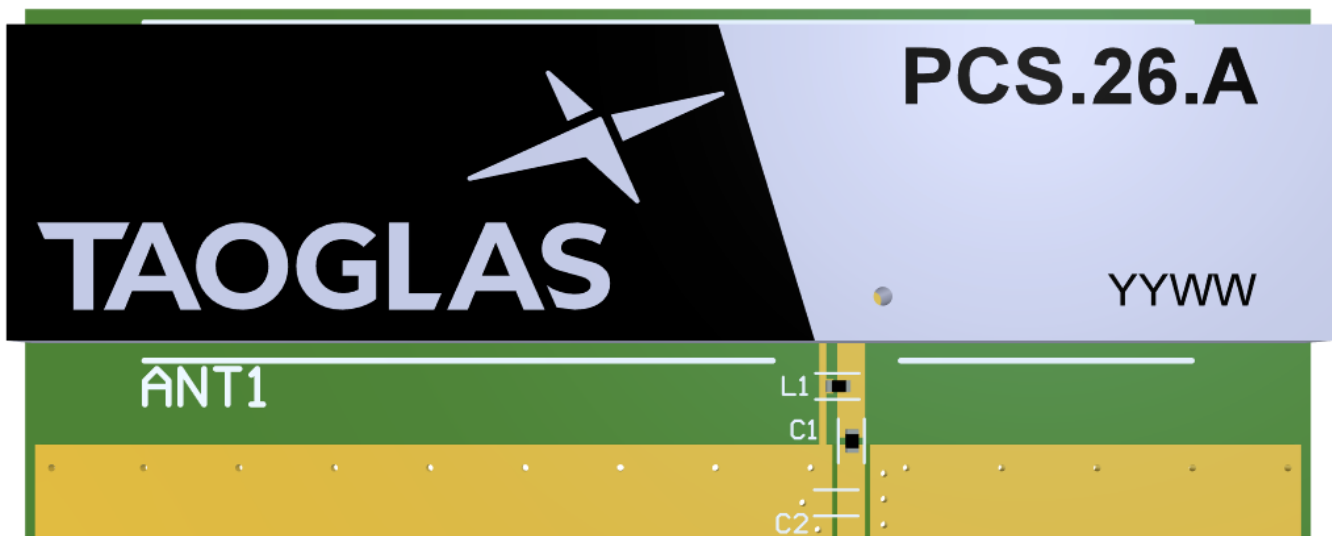

6.4 PCB Layout

The footprint and clearance on the PCB must meet the antenna specification. An example of the PCB layout shows the antenna footprint with clearance. Note the placement of the optimized components. L1 is positioned outside the ground plane and C1 is sitting across the ground plane and the copper clearance area. C2 is optional as a component but it is recommended to include these pads in case they are needed.

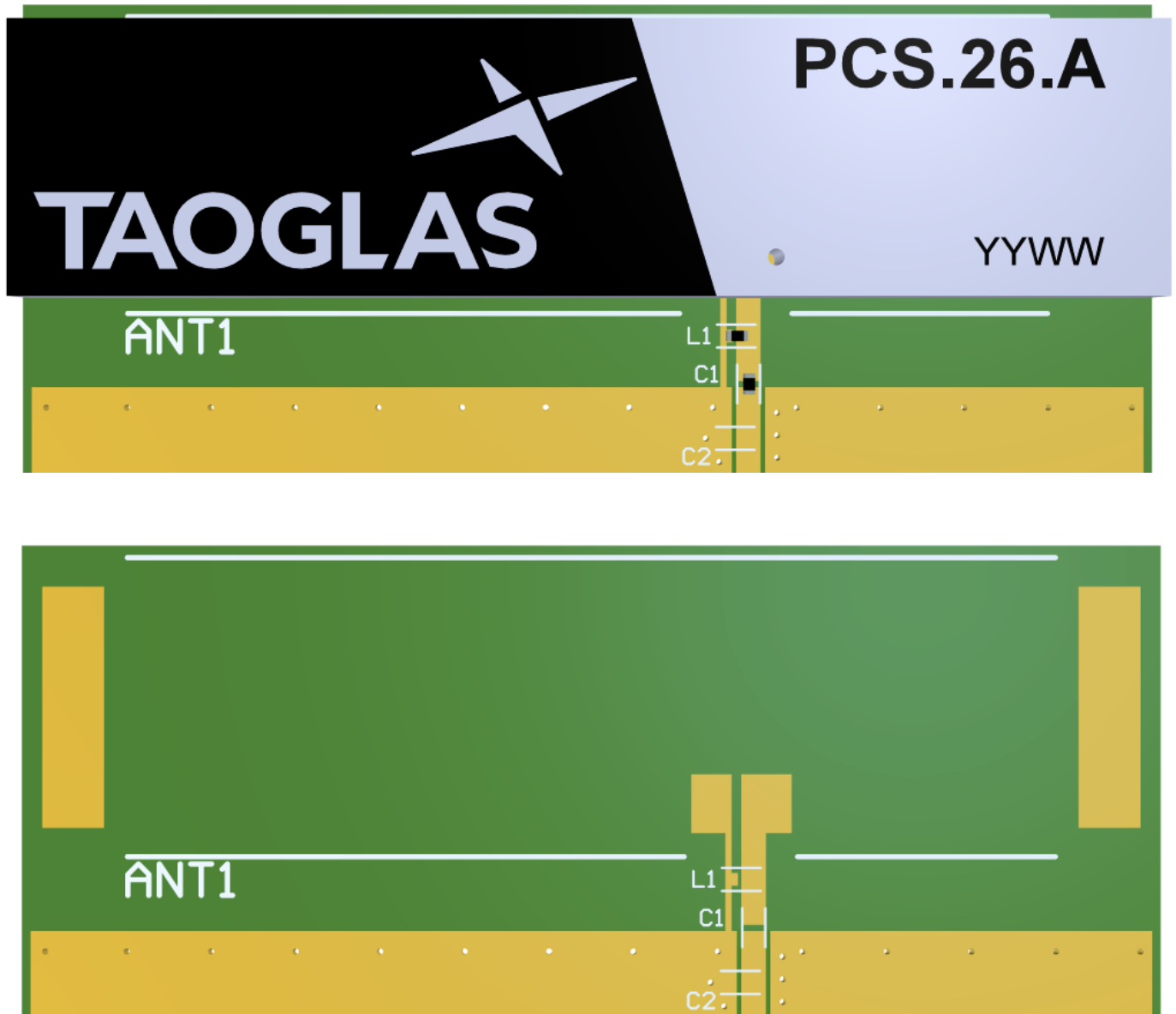

6.5 PCB Clearance

Below shows the antenna footprint and clearance through ALL layers on the PCB. Only the antenna pads and connections to feed and GND are present within this clearance area (marked RED). The clearance area extends to 5mm from the antenna mechanical pads to the ground area. This clearance area includes the bottom side and ALL internal layers on the PCB.

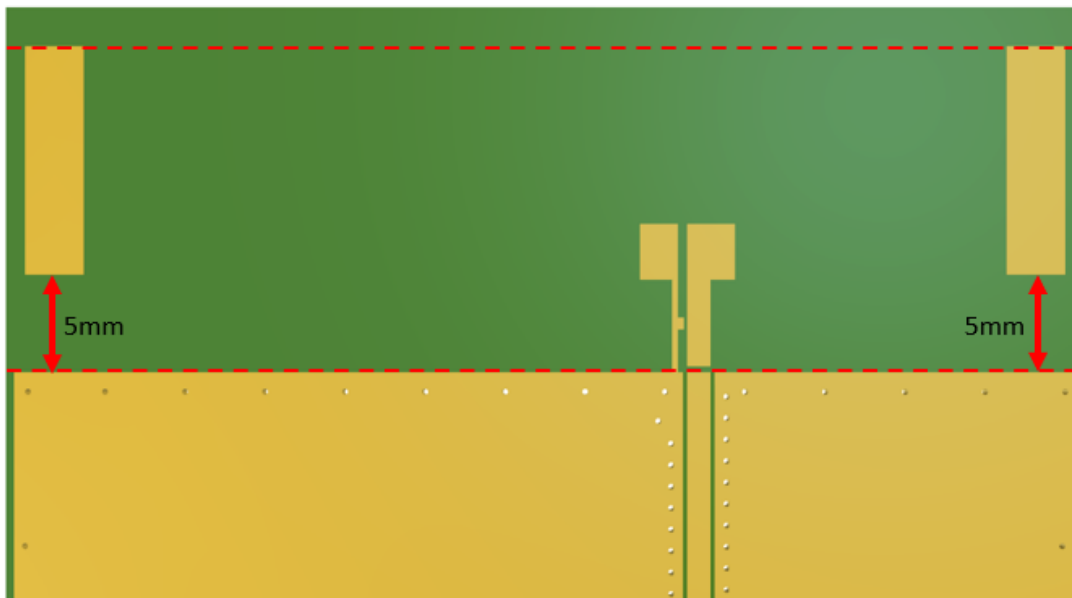

Topside

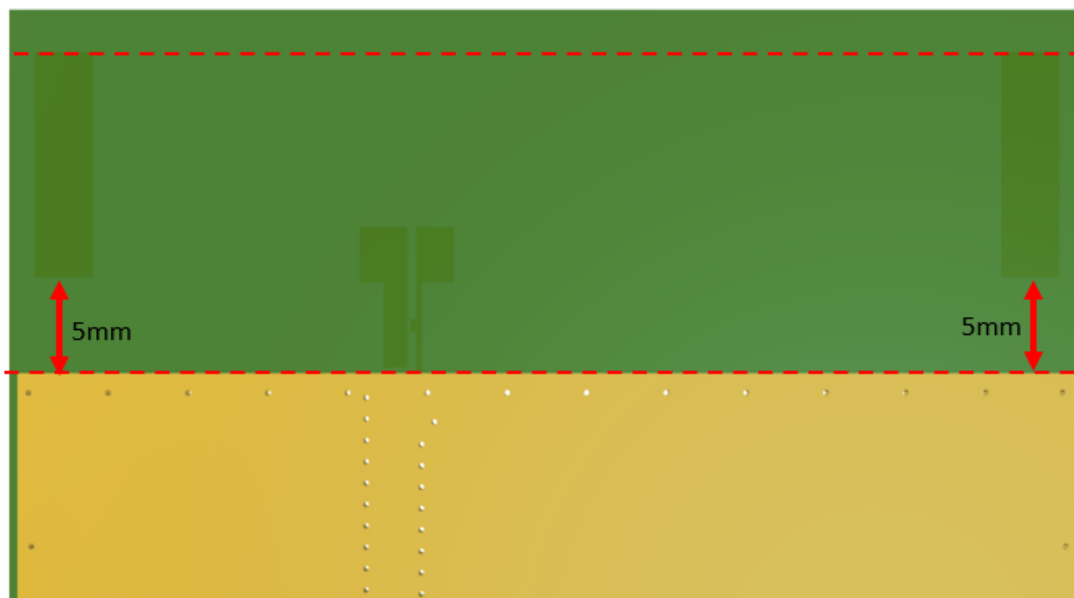

Bottom Side

6.6 Evaluation Board

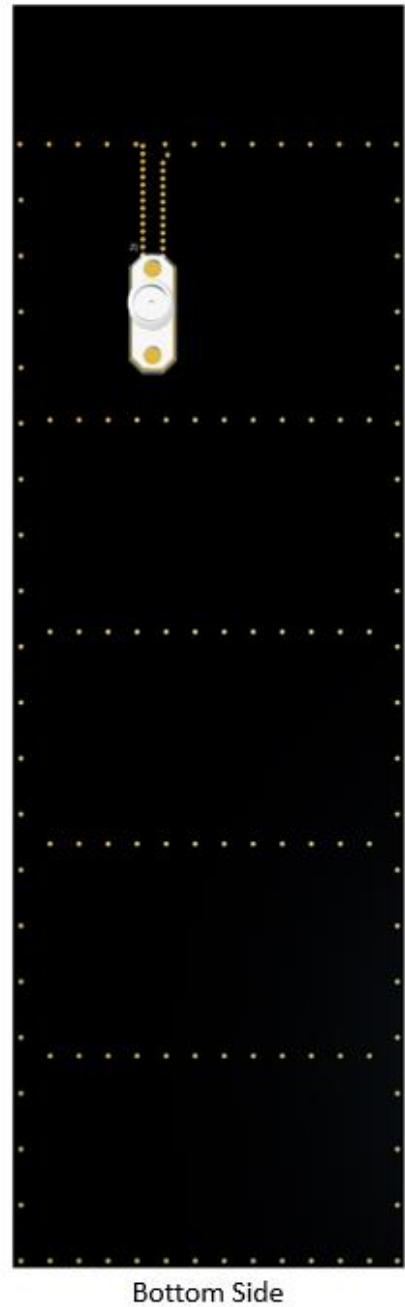
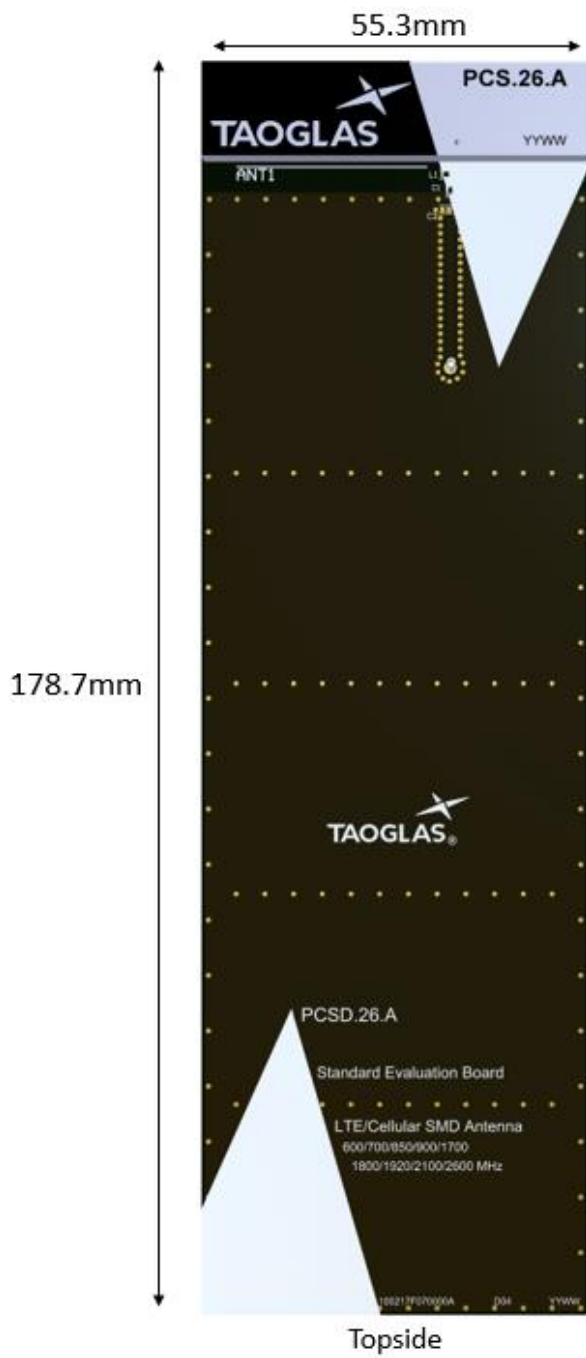

6.7 Evaluation Board Ground Plane Length



Ground Plane Length
160mm

6.8 Evaluation Board Matching Circuit

A matching component (L1) in parallel with the PCS.26.A is required for the antenna to have optimal performance on the evaluation board, located outside of the ground plane in the space specified in the above images. Additional matching components may be necessary for your device, so we recommend incorporating extra component footprints, forming a “pi” network, between the cellular module and the edge of the ground plane.

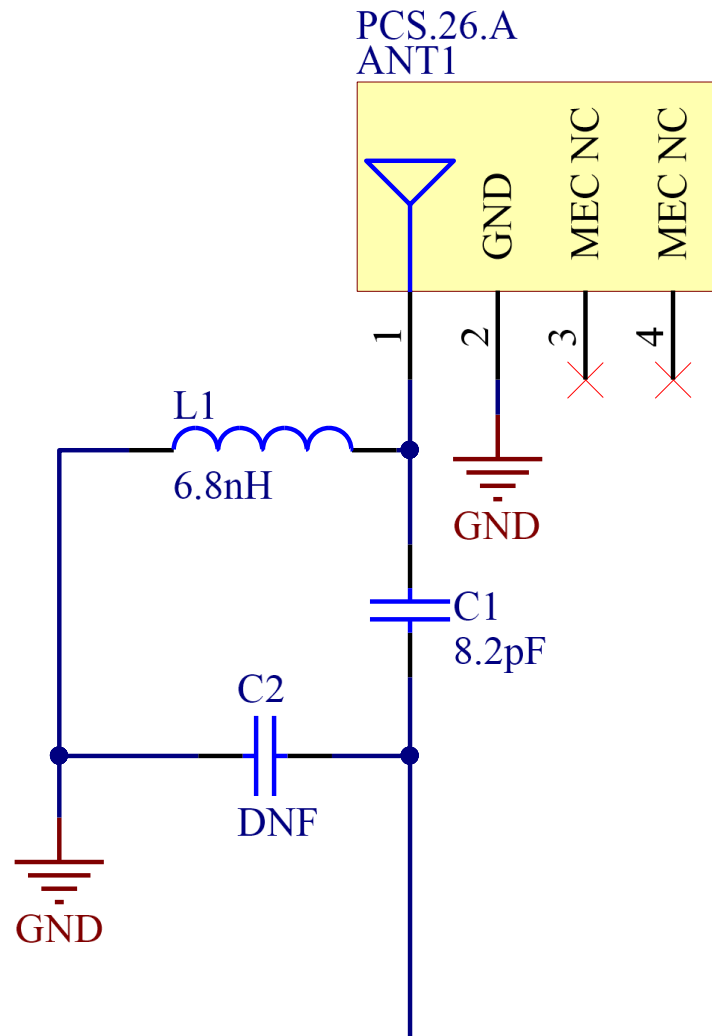

Designator	Type	Value	Description
L1	Inductor	6.8nH	TDK: MLK1005S Series
C1	Capacitor	6.8pF	Murata:GRM1555 Series
C2	Capacitor	DNF	

6.9 Footprint

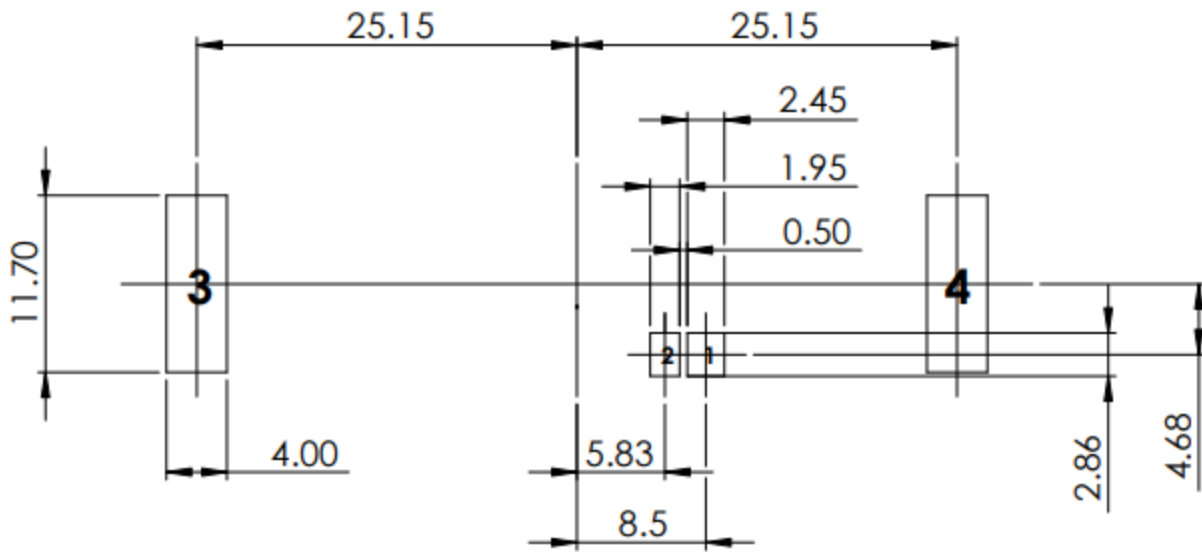

PCB FOOTPRINT

<u>PIN:</u>	<u>DESCRIPTION:</u>
1	Feed (50 ohm)
2	Ground
3,4	NC

7. Packaging

800pcs PCS.26.A per Tape & Reel
 Dimensions - 330*72.5*330mm
 Weight - 3.6Kg

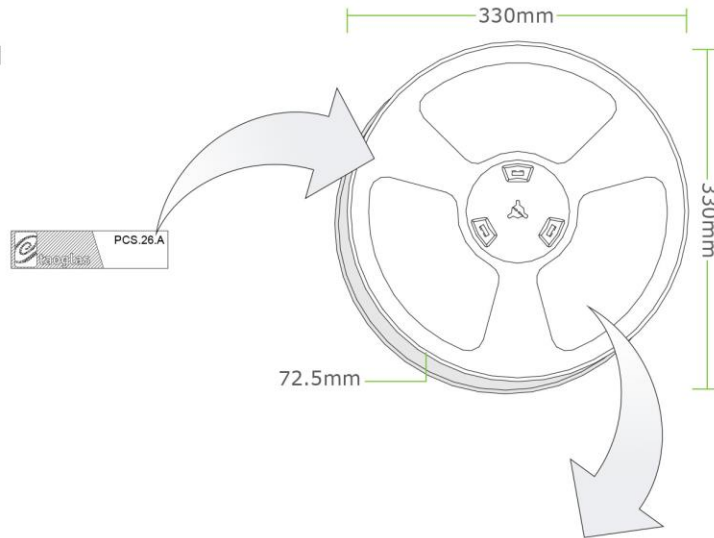

1 Tape & Reel per small box
 Dimensions - 340*340*75mm
 Weight - 3.6Kg

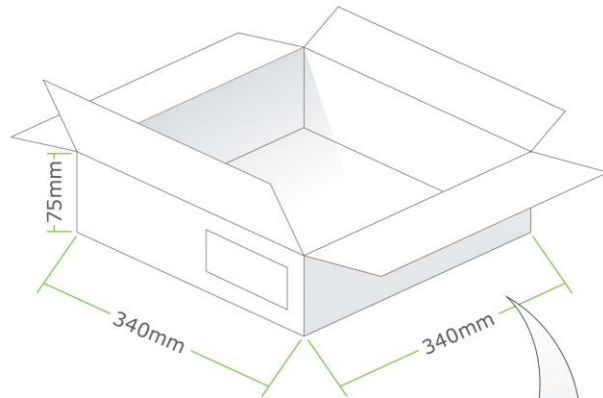

2400 Tape & Reel PCS.26.A per carton
 Dimensions - 370*360*275mm
 Weight - 10.8Kg

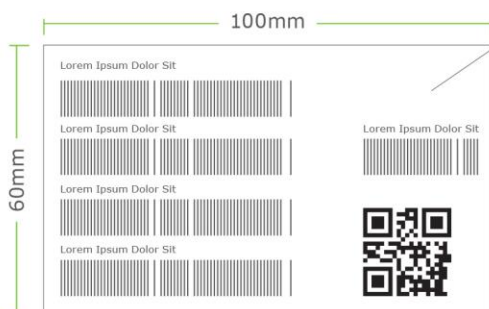
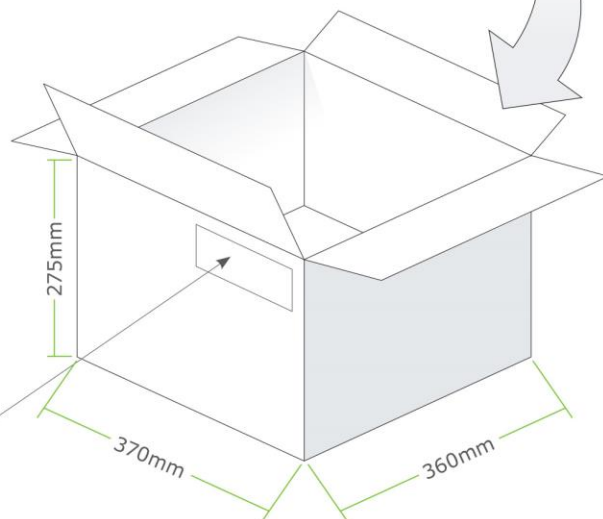

8. Application Note

8.1 Return Loss

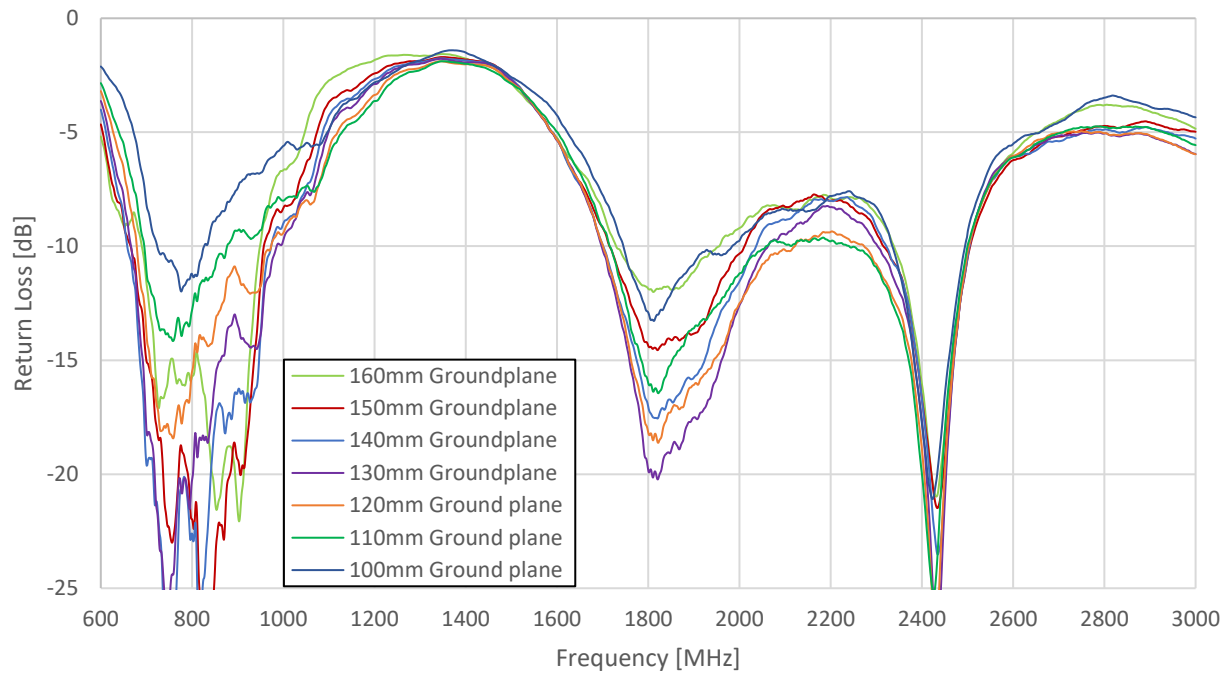

8.2 Return Loss

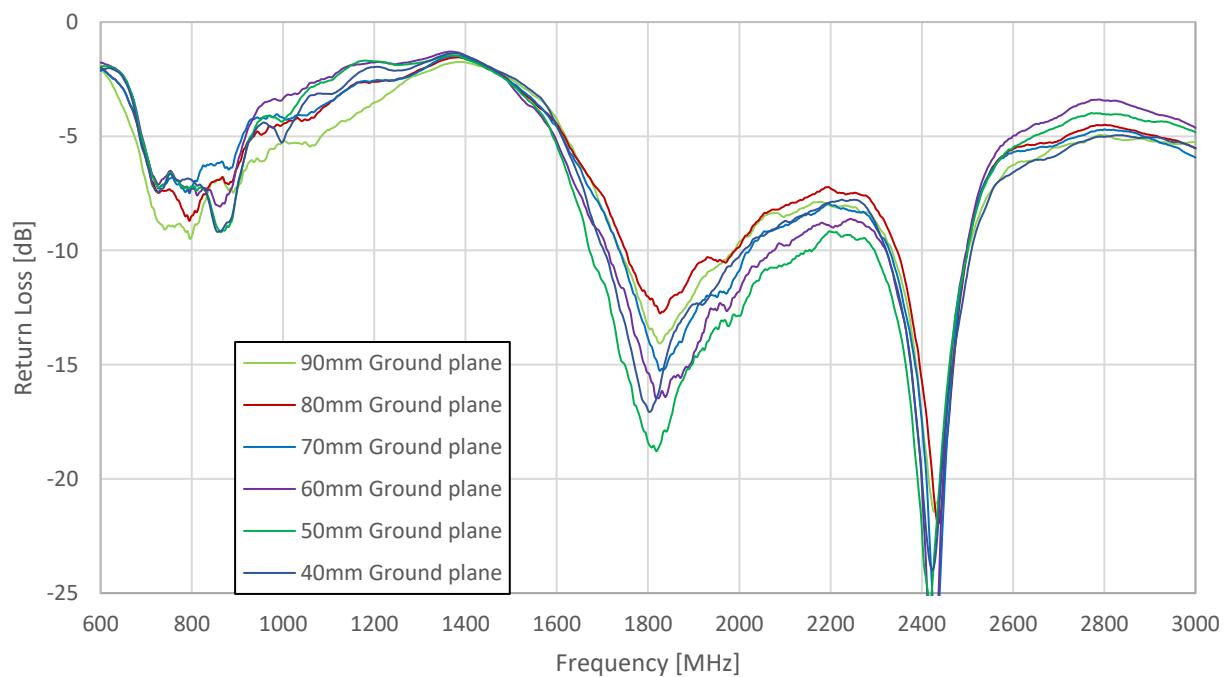

8.3 VSWR

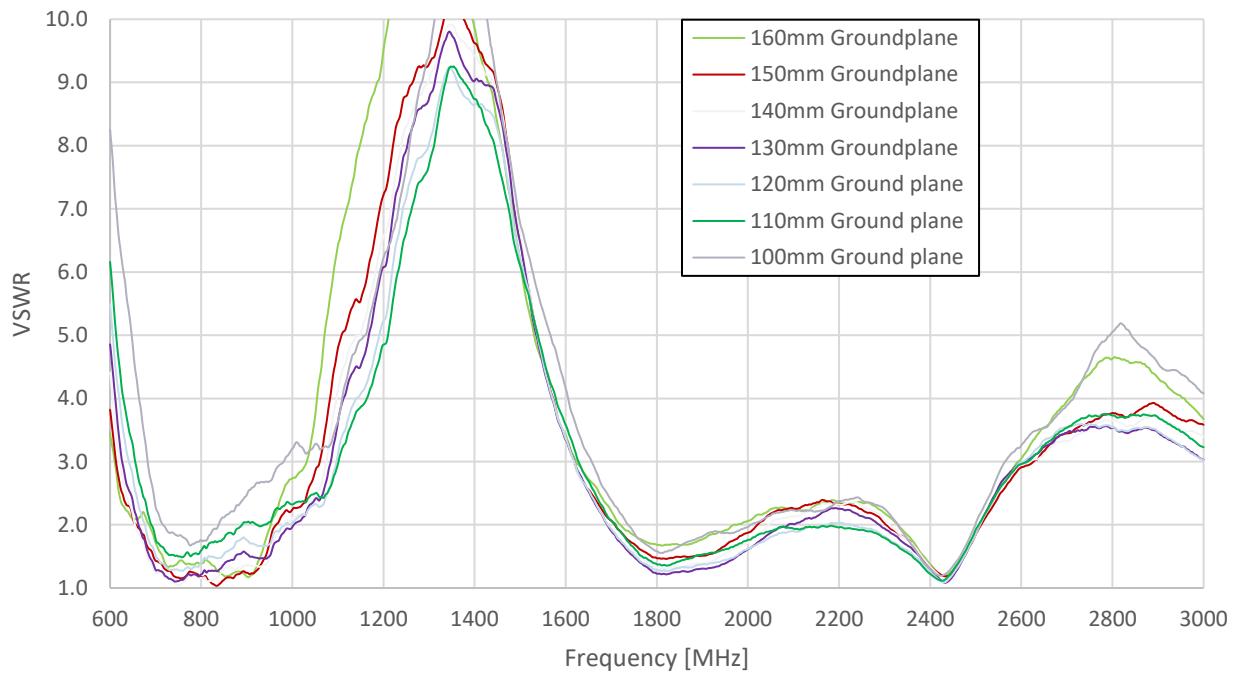

8.4 VSWR

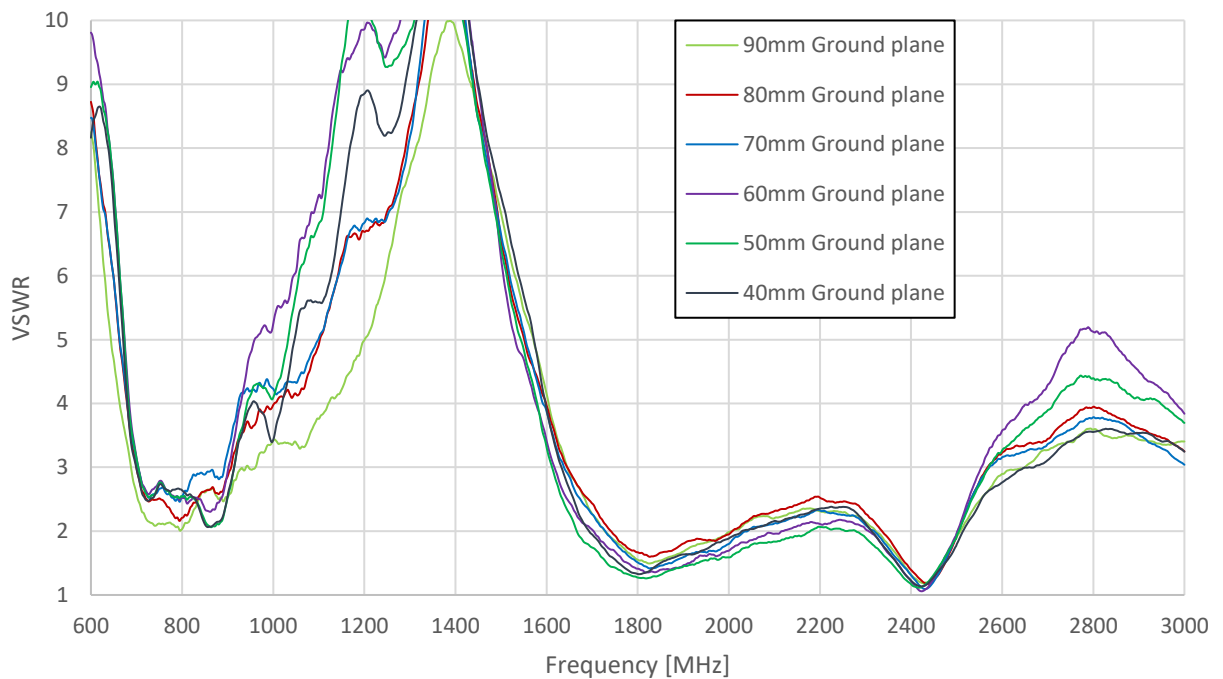

8.5 Efficiency

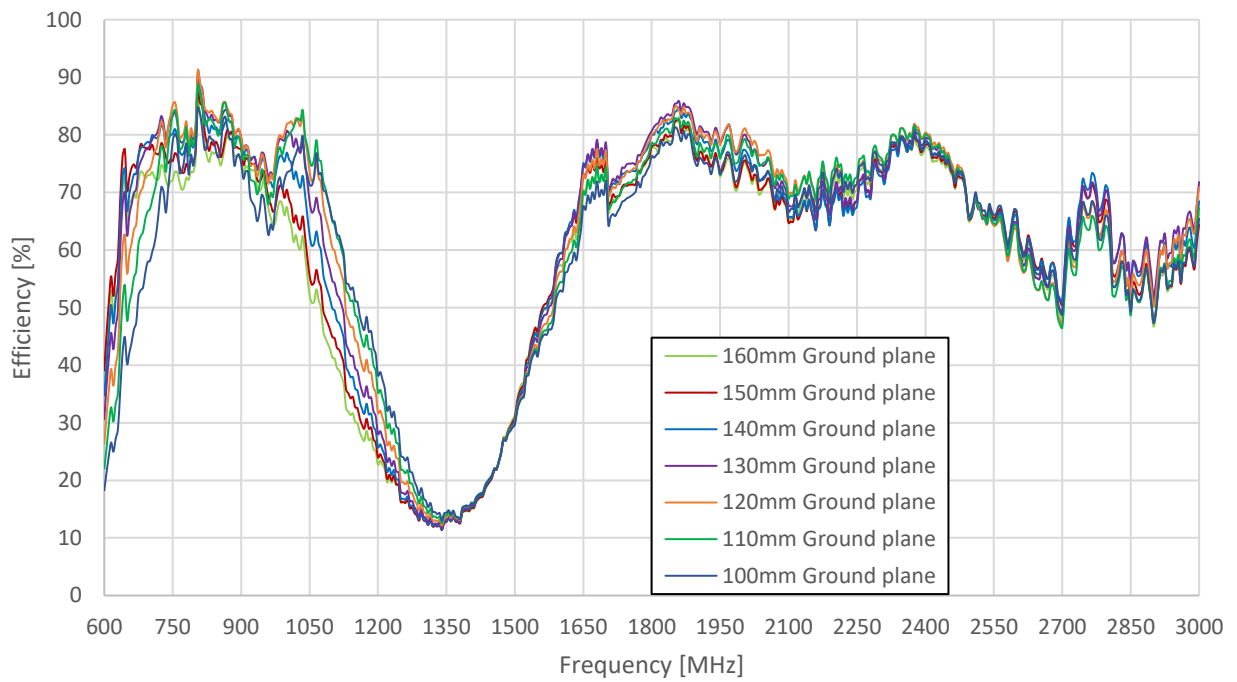

8.6 Efficiency

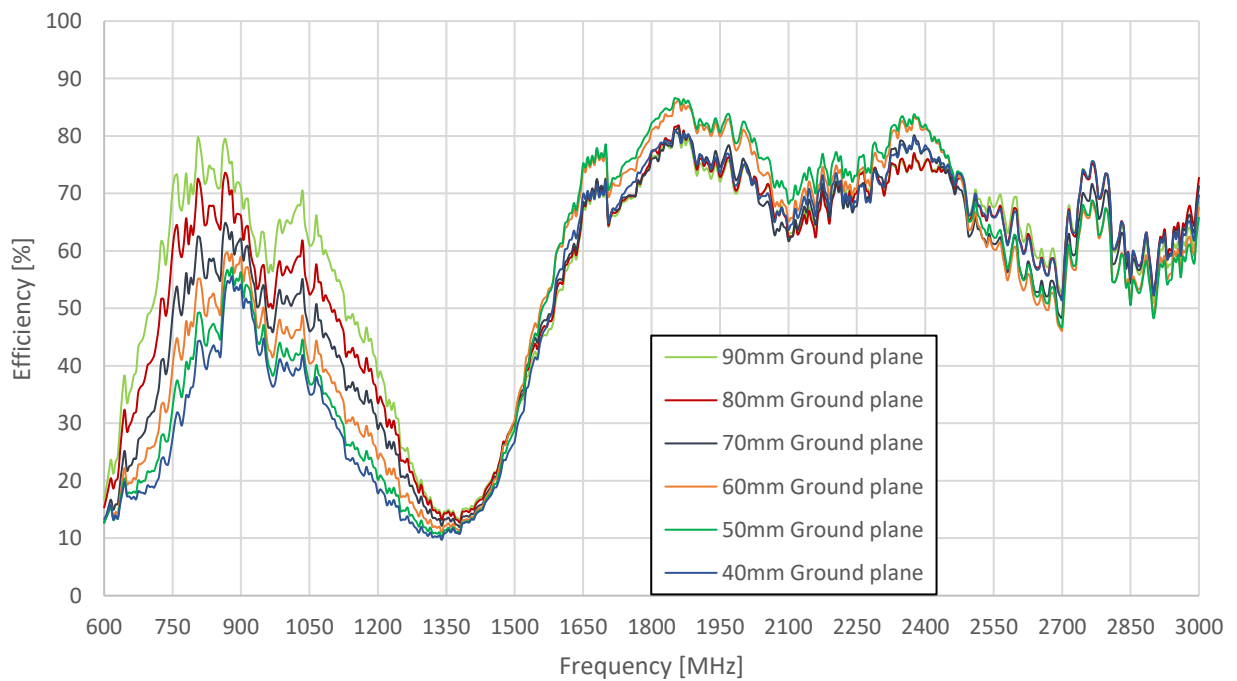

8.7 Peak Gain

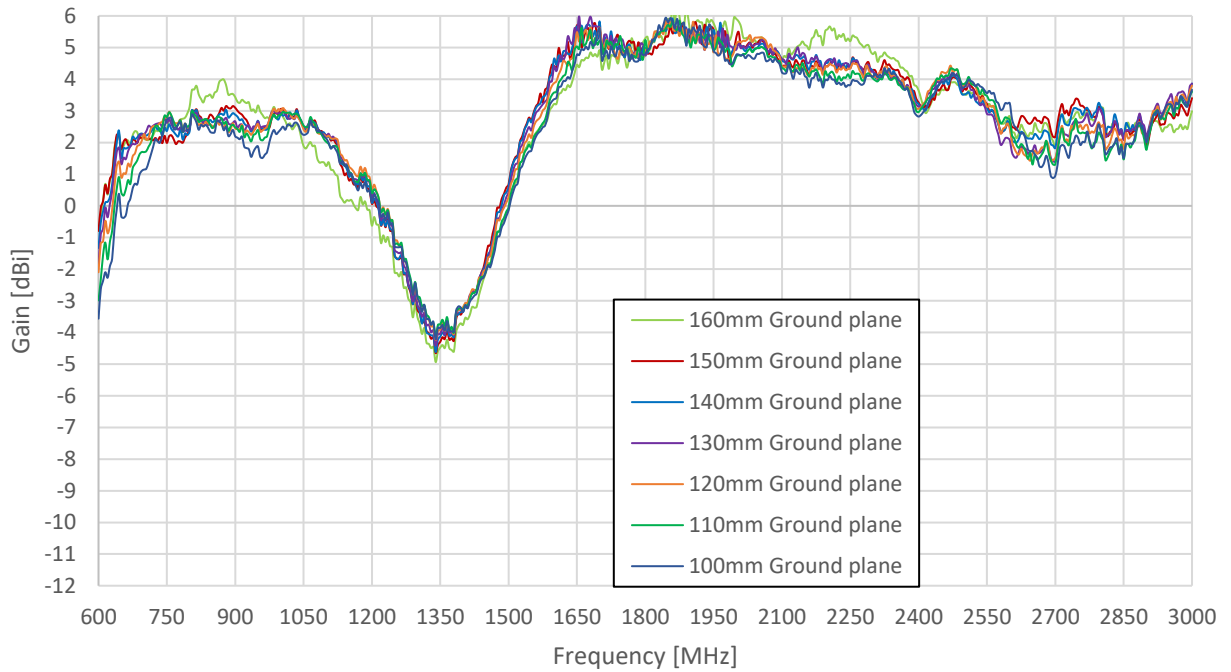

8.8 Peak Gain

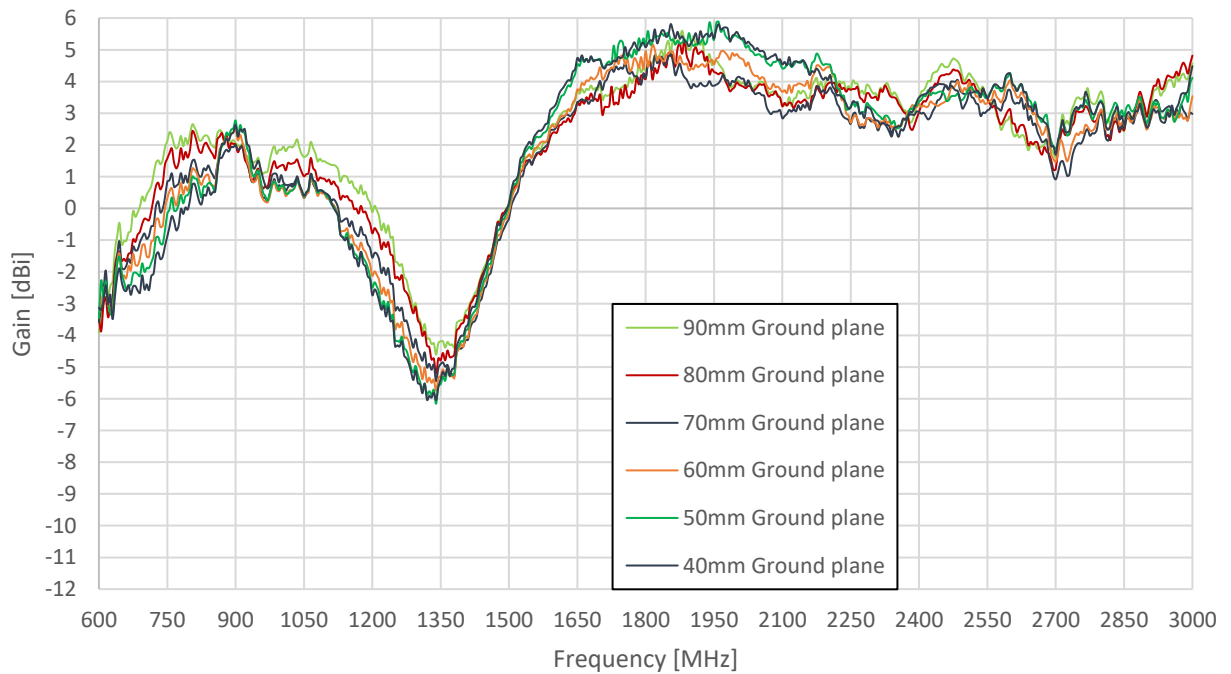

8.9 Average Gain

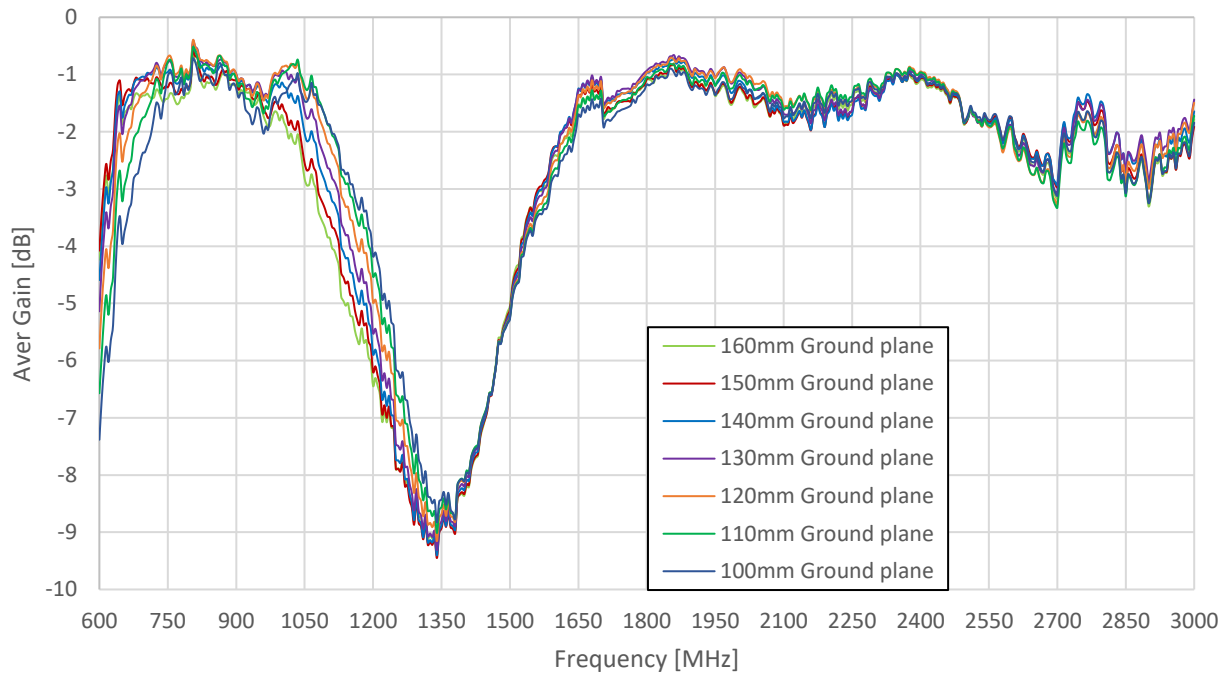

8.10 Average Gain

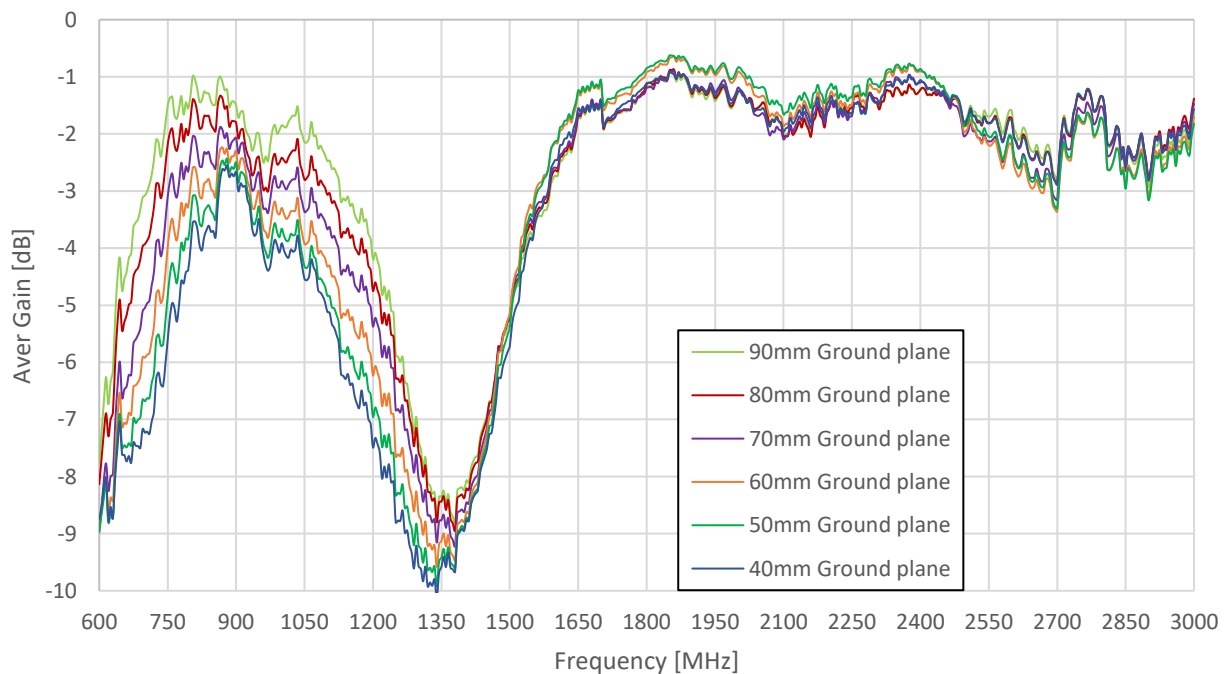

Changelog for the datasheet

SPE-18-8-100 – PCS.26.A

Revision: D (Current Version)

Date:	2021-10-07
Changes:	Updated datasheet template, addition of intergration guide, addition of application note & added MSL to spec table
Changes Made by:	Gary West

Previous Revisions

Revision: C

Date:	
Changes:	
Changes Made by:	AW

Revision: B

Date:	2018-11-19
Changes:	Amended EVB size
Changes Made by:	Jack Conroy

Revision: A (First Release)

Date:	2018-09-11
Changes:	First Release
Changes Made by:	AW



www.taoglas.com



X-ON Electronics

Largest Supplier of Electrical and Electronic Components

Click to view similar products for [Antennas](#) category:

Click to view products by [Taoglas](#) manufacturer:

Other Similar products are found below :

[GAN30084EU](#) [930-033-R](#) [GW17.07.0250E](#) [1513563-1](#) [EXE902SM](#) [APAMPG-117](#) [MAF94383](#) [W3908B0100](#) [W6102B0100](#) [YE572113-30RSMM](#) [108-00014-50](#) [66089-2406](#) [SPDA17RP918](#) [A09-F8NF-M](#) [A09-F5NF-M](#) [RGFRA1903041A1T](#) [W3593B0100](#) [W3921B0100](#) [SIMNA-868](#) [SIMNA-915](#) [SIMNA-433](#) [W1044](#) [W1049B090](#) [A75-001](#) [WTL2449CQ1-FRSMM](#) [CPL9C](#) [EXB148BN](#) [0600-00060](#) [TRA9020S3PBN-001](#) [GD5W-28P-NF](#) [MA9-7N](#) [GD53-25](#) [GD5W-21P-NF](#) [C37](#) [MAF94051](#) [MA9-5N](#) [EXD420PL](#) [B1322NR](#) [QWFTB120](#) [MAF94271](#) [MAF94300](#) [GPSMB301](#) [FG4403](#) [AO-AGSM-OM54](#) [5200232](#) [MIKROE-2349](#) [WCM.01.0111](#) [MIKROE-2393](#) [MIKROE-2352](#) [MIKROE-2350](#)