

SGP.25c

Specification

Part No.	SGP.1575.25.4.C.02
Product Name	GPS SMT Patch Antenna
Features	<p>25mm*25mm*4.5mm 1575MHz Centre Frequency Patent pending</p> <p>RoHS Compliant</p>

1. Introduction

This ceramic GPS patch antenna is based on smart **XtremeGain™** technology. It is mounted via SMT process and has been selected as optimal solution for the 45x45mm ground plane.

2. Specification

Original Patch Specification tested on 45mm ground plane

NO	PARAMETER	SPECIFICATION	NOTES
1	Range of Receiving Frequency	1575.42 MHz ± 1.023 MHz	
2	Center Frequency	1575.42 ± 3MHz	With 45*45mm Ground Plane
3	Bandwidth	8MHz min	Return Loss ≤ -10 dB
4	Return Loss	≤ -10 dB	
5	VSWR	1.5 max	Centre Frequency
6	Gain at Zenith	+2.0 dBic typ.	Centre Frequency
7	Gain at 10°elevation	-1.0 dBic typ.	Centre Frequency
8	Axial Ratio	3.0 dB max	Centre Frequency
9	Polarization	RHCP	Centre Frequency
10	Impedance	50 Ohms	Centre Frequency
11	Frequency Temperature Coefficient (τf)	0 ± 20ppm / °C	-40°C to +85°C
12	Operating Temperature	-40°C to +85°C	

****Changes in user groundplane and environment will offset centre frequency**

3. Electrical Specifications

3.1 Return Loss, SWR, Impedance, measured on the test fixture

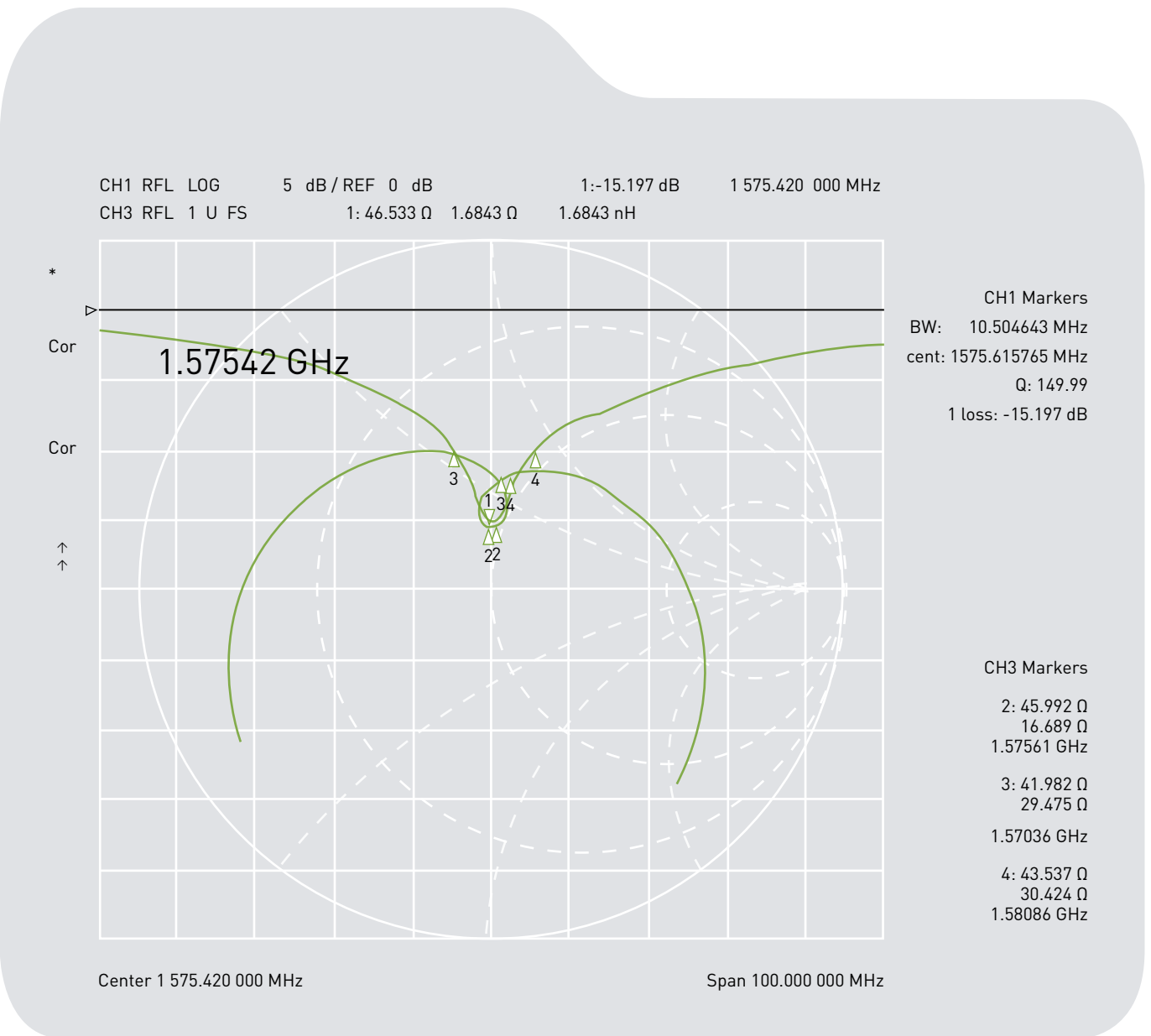

3.2 2D Radiation Pattern

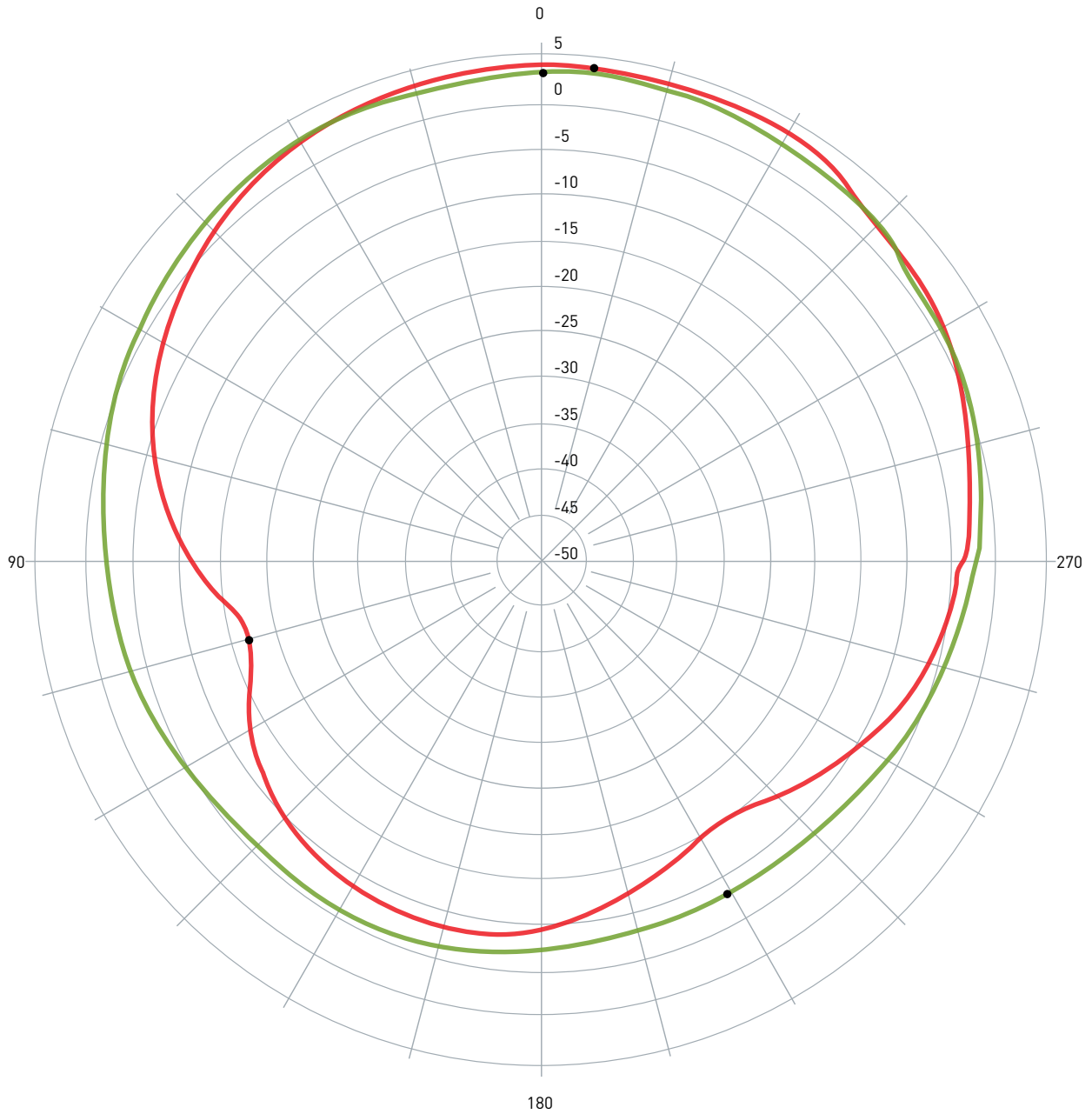

Pattern	Model No.	Test Mode	Freq (MHz)	Max Gain(dBi)	Min Gain(dBi)	Avg. Gain(dBi)	Source Polar.
1 	SGP.25.C	XZ	1575.42	3.70 / 354.00	-17.00 / 105.00	-1.61	RHCP
2 	SGP.25.C	YZ	1575.42	2.92 / 0.00	-8.76 / 2099.00	-0.96	RHCP



Date: 2009 / 9 / 4

4. Mechanical Specifications

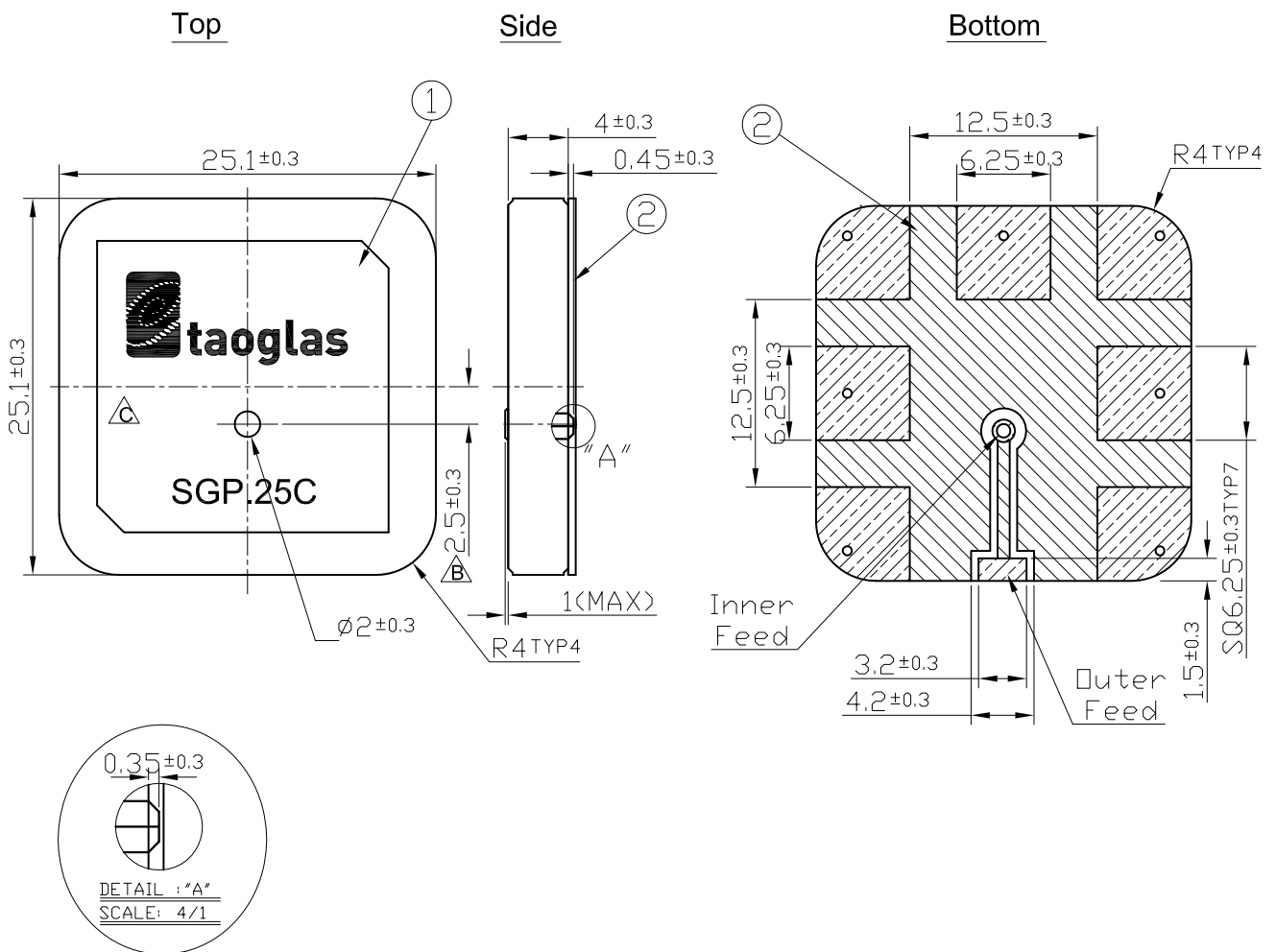
4.1 Antenna Dimensions and Drawing



NOTE:

1. Solder mask. 
2. Area to be soldered. 
3. Dimension of 50 Ohm CPW dependent on individual board.
4. Matching circuit-capacitor and inductor values dependent on individual environment
5. Must be soldered to complete antenna feed connection

	Name	Part No.	Material	Finish	Quantity
1	SGP.25 Patch 25x25x4	SGP.25C	Ceramic	Clear	1
2	SGP.25 PCB		FR 0.5t	Green	1

4.2 Antenna Footprint

4.2.1 Top Copper

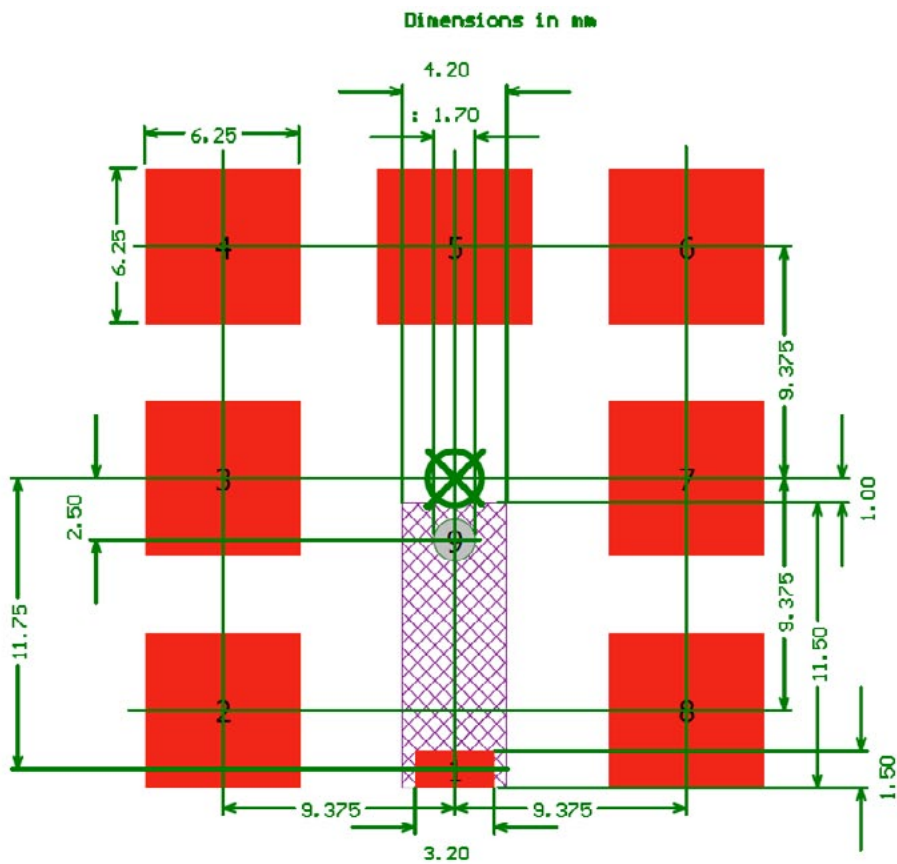

 **Copper Keepout Region**

Pads 2, 3, 4, 5, 6, 7, 8 are the same size and should be connected to GND.
 Pad 9 is a 1.70mm dia. non-plated thru-hole.
 Connect 50 ohm transmission line to Pad 1.
 Copper Keepout Region should extend at least 2mm down into PCB.

4.2 Antenna Footprint

4.2.2 Top Paste

Dimensions in mm

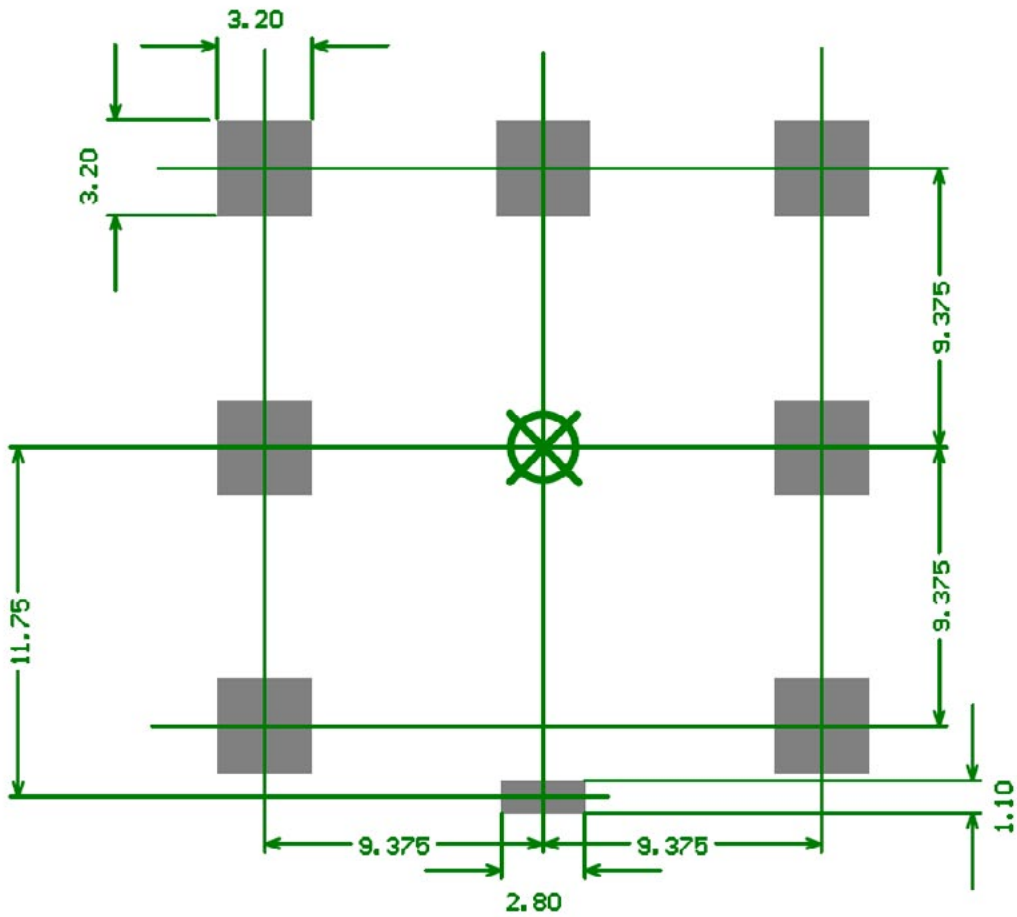

4.2 Antenna Footprint

4.2.3 Top Mask

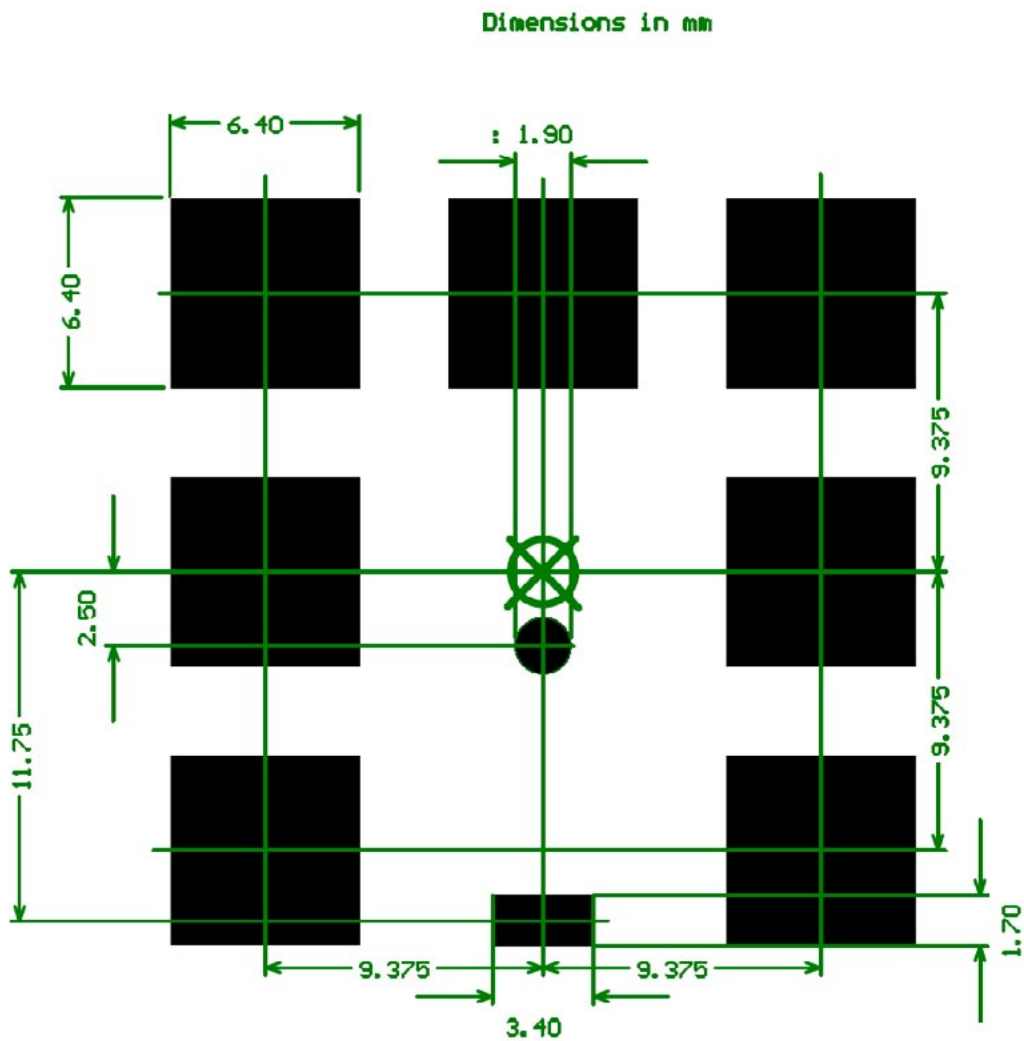

4.2 Antenna Footprint

4.2.4 Composite

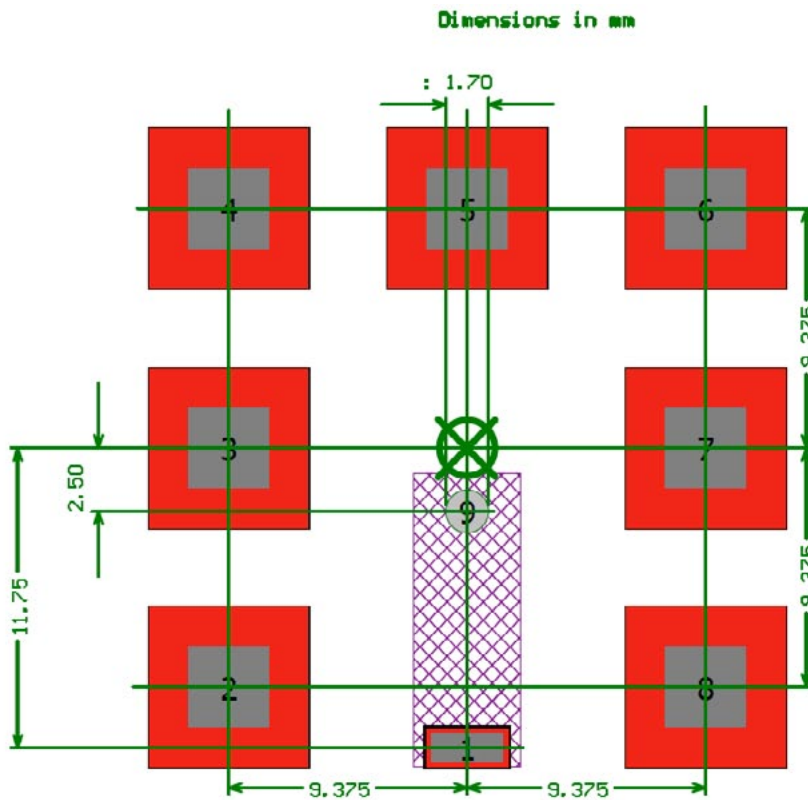

 Copper Keepout Region

Pads 2, 3, 4, 5, 6, 7, 8 are the same size and should be connected to GND.

Pad 9 is a 1.70mm dia. non-plated thru-hole.



Connect 50 ohm transmission line to Pad 1.

Copper Keepout Region should extend at least 2 mm down into PCB.

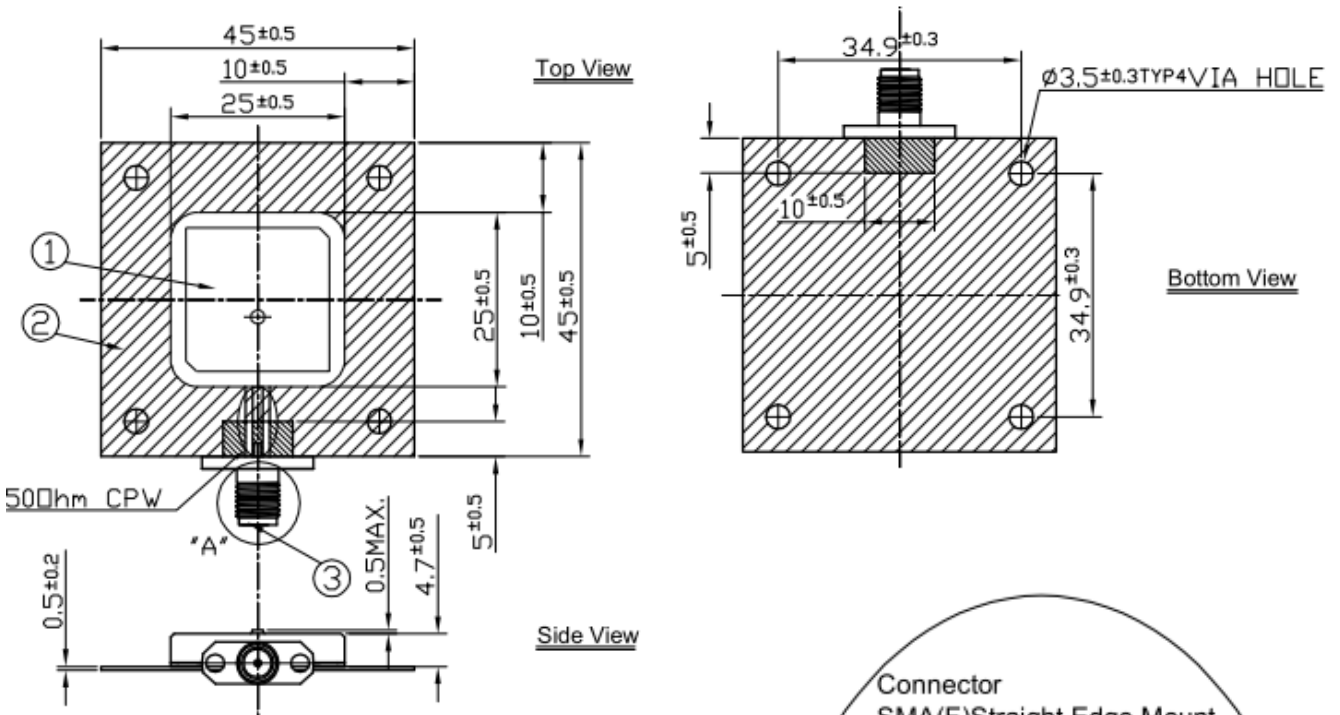
4.3 Test Jig and Dimension



NOTE:

- 1. Solder Mask (Black) 
- 2. Solder Area 

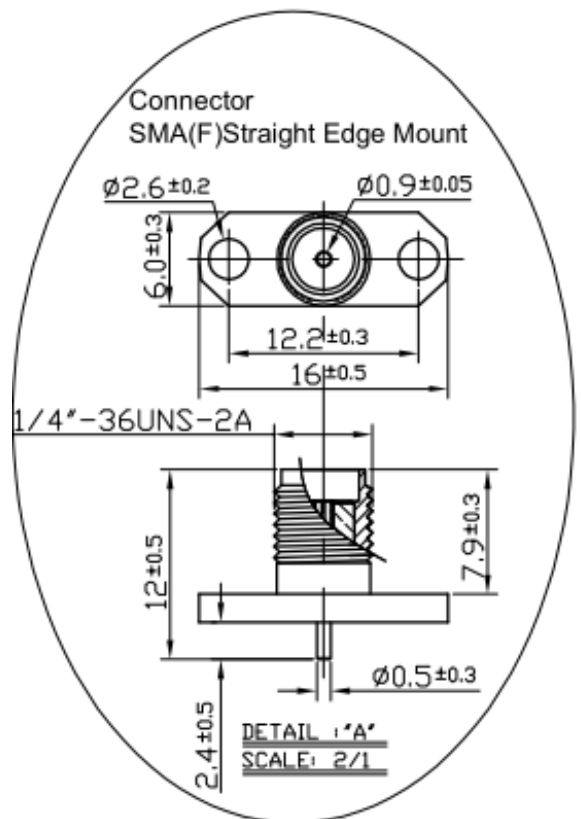

4.4 Test Fixture set up and measurements

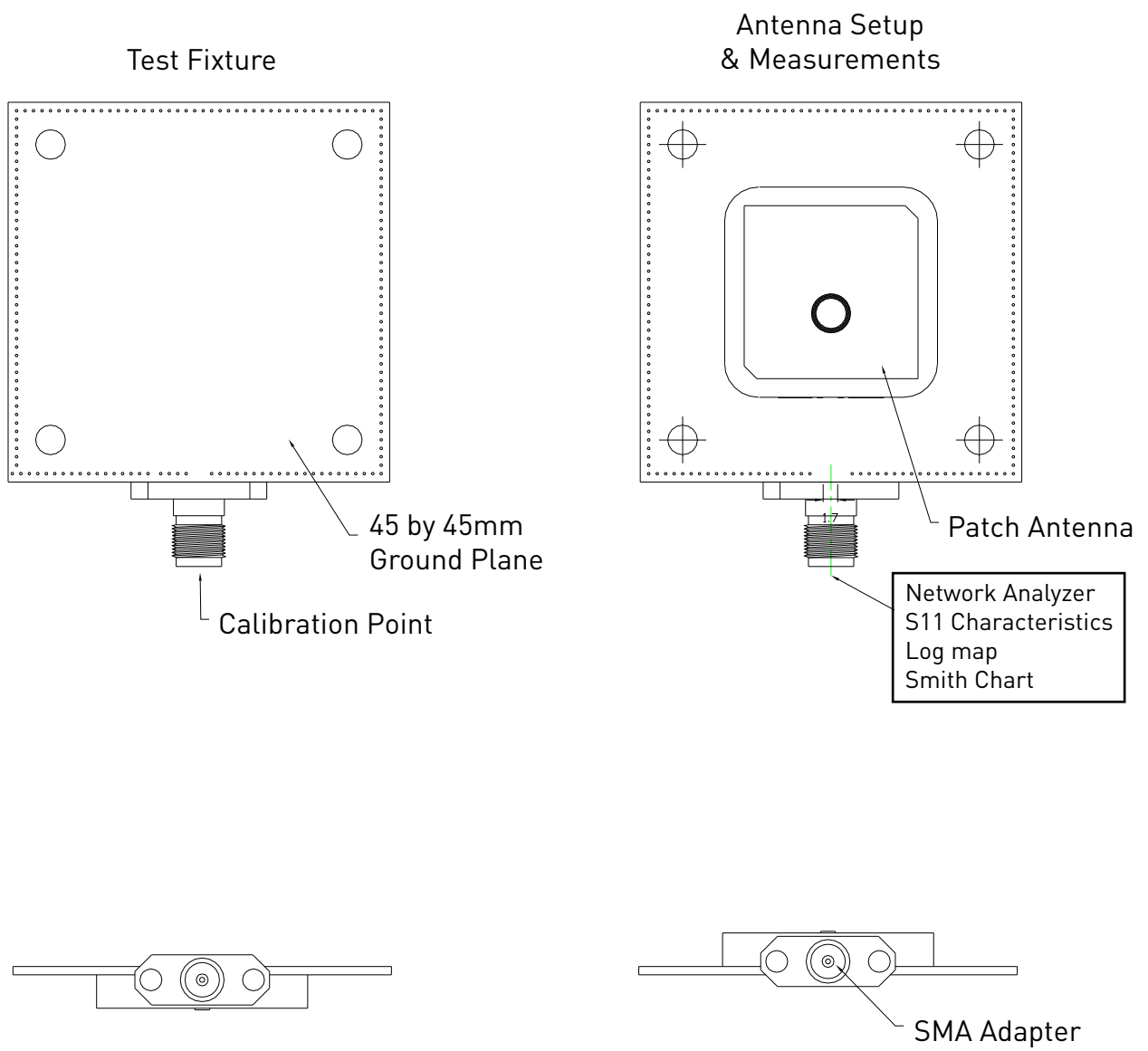

5. Recommended Reflow Soldering Profile

SGP.25.C can be assembled following Pb-free assembly. According to the Standard IPC/JEDEC J-STD-020C, the temperature profile suggested is as follow:

PHASE	PROFILE FEATURES	Pb-Free Assembly (SnAgCu)
PREHEAT	Temperature Min(T_{smin})	150°C
	Temperature Max(T_{smax})	200°C
	Time(t_s) from (T_{smin} to T_{smax})	60-120 seconds
RAMP-UP	Avg. Ramp-up Rate (T_{smax} to TP)	3°C/second(max)
REFLOW	Temperature(T_L)	217°C
	Total Time above T_L (t_L)	30-100 seconds
PEAK	Temperature(T_P)	260°C
	Time(t_p)	2-5 seconds
RAMP-DOWN	Rate	3°C/second(max)
Time from 25°C to Peak Temperature		8 minutes max.
Composition of solder paste		96.5Sn/3Ag/0.5Cu
Solder Paste Model		SHENMAO PF606-P26

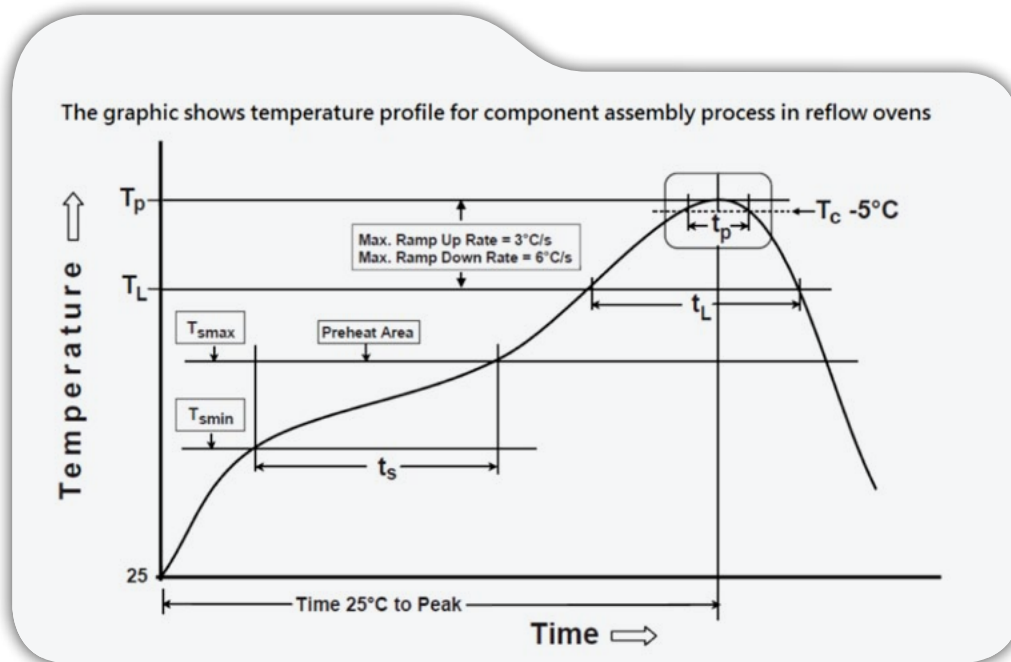

Soldering Iron condition: Soldering iron temperature $270^\circ\text{C} \pm 10^\circ\text{C}$.

Apply preheating at 120°C for 2-3 minutes. Finish soldering for each terminal within 3 seconds, if soldering iron temperature over $270^\circ\text{C} \pm 10^\circ\text{C}$ or 3 seconds, it will make cause component surface peeling or damage.

6. Packaging

200 pcs per reel / inner carton
4 reels per outer carton - 800 pcs

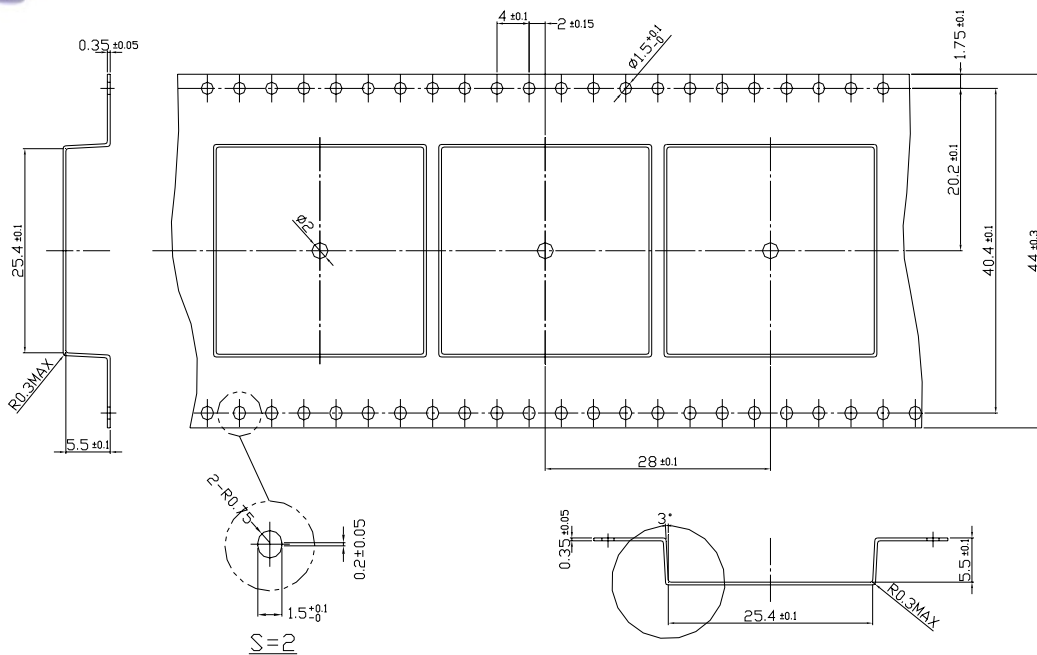
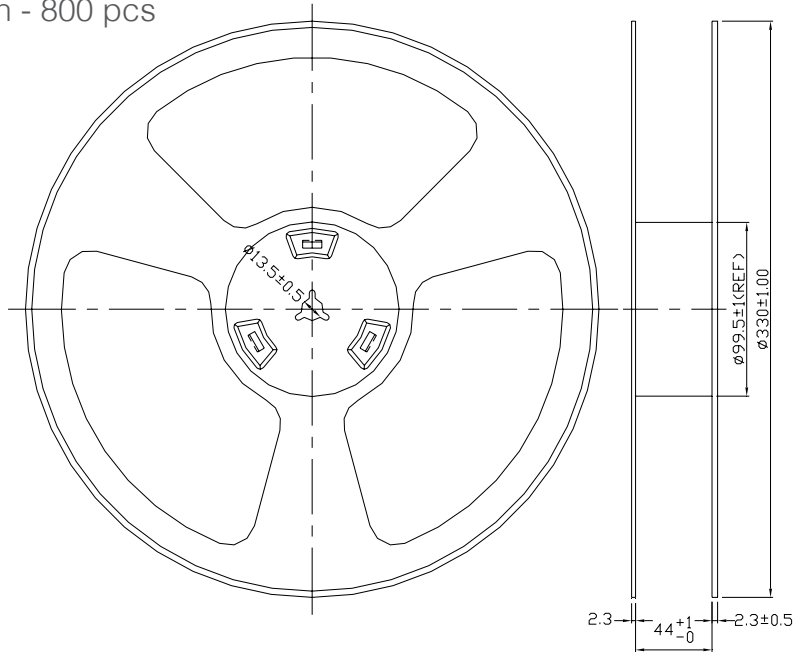

Unit: mm

Taoglas makes no warranties based on the accuracy or completeness of the contents of this document and reserves the right to make changes to specifications and product descriptions at any time without

notice. Taoglas reserves all rights to this document and the information contained herein.

Reproduction, use or disclosure to third parties without express permission is strictly prohibited.

Copyright © Taoglas Ltd.

X-ON Electronics

Largest Supplier of Electrical and Electronic Components

Click to view similar products for [Antennas](#) category:

Click to view products by [Taoglas](#) manufacturer:

Other Similar products are found below :

[GAN30084EU](#) [930-033-R](#) [GW17.07.0250E](#) [1513563-1](#) [EXE902SM](#) [APAMPG-117](#) [MAF94383](#) [W3908B0100](#) [W6102B0100](#) [YE572113-30RSMM](#) [108-00014-50](#) [66089-2406](#) [SPDA17RP918](#) [A09-F8NF-M](#) [A09-F5NF-M](#) [RGFRA1903041A1T](#) [W3593B0100](#) [W3921B0100](#) [SIMNA-868](#) [SIMNA-915](#) [SIMNA-433](#) [W1044](#) [W1049B090](#) [A75-001](#) [WTL2449CQ1-FRSMM](#) [CPL9C](#) [EXB148BN](#) [0600-00060](#) [TRA9020S3PBN-001](#) [Y4503](#) [GD5W-28P-NF](#) [MA9-7N](#) [GD53-25](#) [GD5W-21P-NF](#) [C37](#) [MAF94051](#) [MA9-5N](#) [EXD420PL](#) [B1322NR](#) [QWFTB120](#) [MAF94271](#) [MAF94300](#) [GPSMB301](#) [FG4403](#) [AO-AGSM-OM54](#) [5200232](#) [MIKROE-2349](#) [WCM.01.0111](#) [MIKROE-2393](#) [MIKROE-2352](#)