

SPECIFICATION

Part No.	:	SWLP.2450.12.4.B.02
Product Name	:	12*12*4mm 2.4GHz SMD Patch Antenna
Features	:	2.4 - 2.5GHz Patch Antenna For Wi-Fi/WLAN/ISM/Zigbee Industrial Applications High Gain 2dBi Linearly Polarized ROHS Compliant

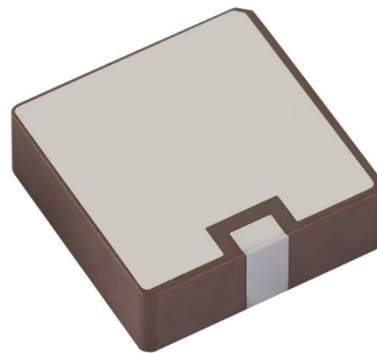

Top



Bottom

1. Introduction

This 12*12*4mm high gain 2.4GHz patch antenna is ideally suited for high performance industrial applications in the 2.4GHz Wi-Fi, ISM, and Zigbee bands. This product has highest gain in the XZ (azimuth) plane direction, most suitable for fixed wireless applications where transmission and reception is focused to one hemisphere of the device, for example a wireless meter on a reinforced concrete wall. It can also be placed anywhere on the device ground-plane, unlike most chip or loop antennas which need to be edge mounted.

Many module manufacturers specify peak gain limits for any antennas that are to be connected to that module. Those peak gain limits are based on free-space conditions. In practice, the peak gain of an antenna tested in free-space can degrade by at least 1 or 2dBi when put inside a device. So ideally you should go for a slightly higher peak gain antenna than mentioned on the module specification to compensate for this effect, giving you better performance.

Upon testing of any of our antennas with your device and a selection of appropriate layout, integration technique, or cable, Taoglas can make sure any of our antennas' peak gain will be below the peak gain limits. Taoglas can then issue a specification and/or report for the selected antenna in your device that will clearly show it complying with the peak gain limits, so you can be assured you are meeting regulatory requirements for that module.

For example, a module manufacturer may state that the antenna must have less than 2dBi peak gain, but you don't need to select an embedded antenna that has a peak gain of less than 2dBi in free-space. This will give you a less optimized solution. It is better to go for a slightly higher free-space peak gain of 3dBi or more if available. Once that antenna gets integrated into your device, performance will degrade below this 2dBi peak gain due to the effects of GND plane, surrounding components, and device housing. If you want to be absolutely sure, contact Taoglas and we will test. Choosing a Taoglas antenna with a higher peak gain than what is specified by the module manufacturer and enlisting our help will ensure you are getting the best performance possible without exceeding the peak gain limits.

It is better not to select an embedded antenna with very low free-space peak gain (<2dBi) directly, as this antenna would have worse performance in your device, and lead to compromised performance compared to using a Taoglas antenna.

2. Key Antenna Performance Indicators*

ELECTRICAL	
Frequency Range	2400 MHz to 2500 MHz
Bandwidth	100 MHz @ -7dB
Efficiency	80.12% @ 2450 MHz
Polarization	Linear
VSWR	3.0 max @ Center Frequency
Peak Gain	+2 dBi typ.
Impedance	50 Ohms
MECHANICAL	
Dimensions	12mm x 12mm x 4mm
Weight	4g
ENVIRONMENTAL	
Operating Temperature	-40°C to +85°C
Storage Temperature	-40°C to +85°C
Termination	Ag (Environmentally Friendly Pb Free)

Original Patch Specification measured on EVB 50*50mm. Actual value depends on ground-plane and housing

3. Electrical Specifications

3.1 Return Loss

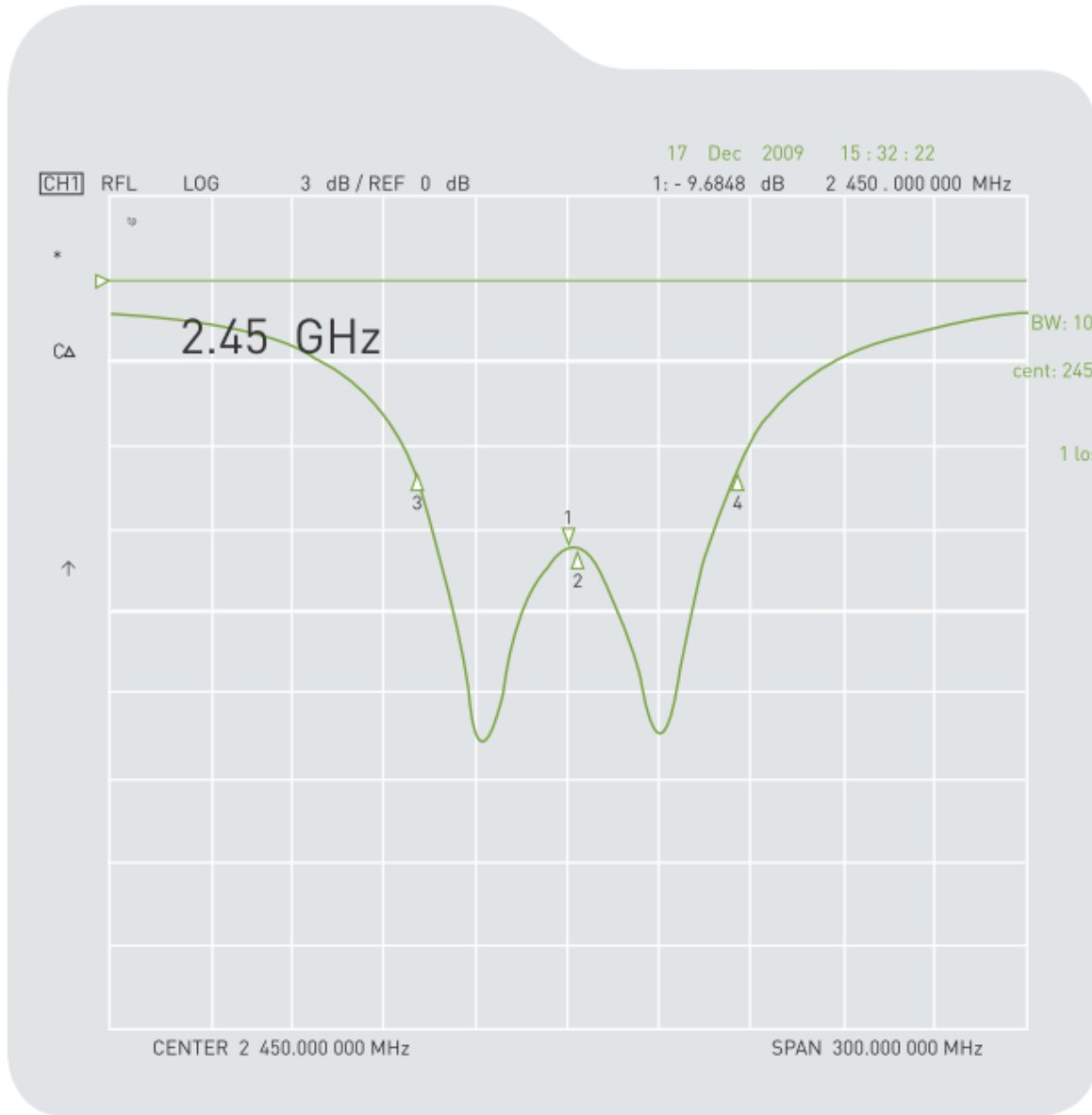

With 50x50mm² Evaluation board

3.2 Definition of X-Y-Z Plane

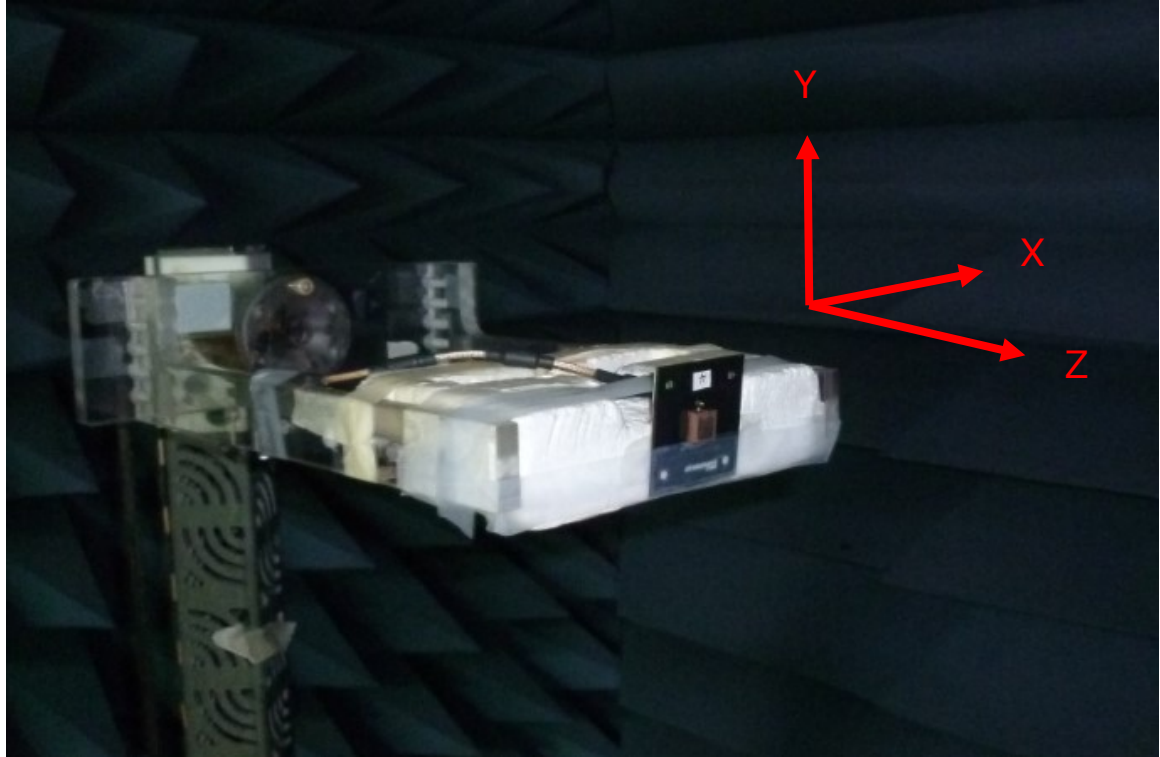

3.3 Radiation Patterns

XY Plane

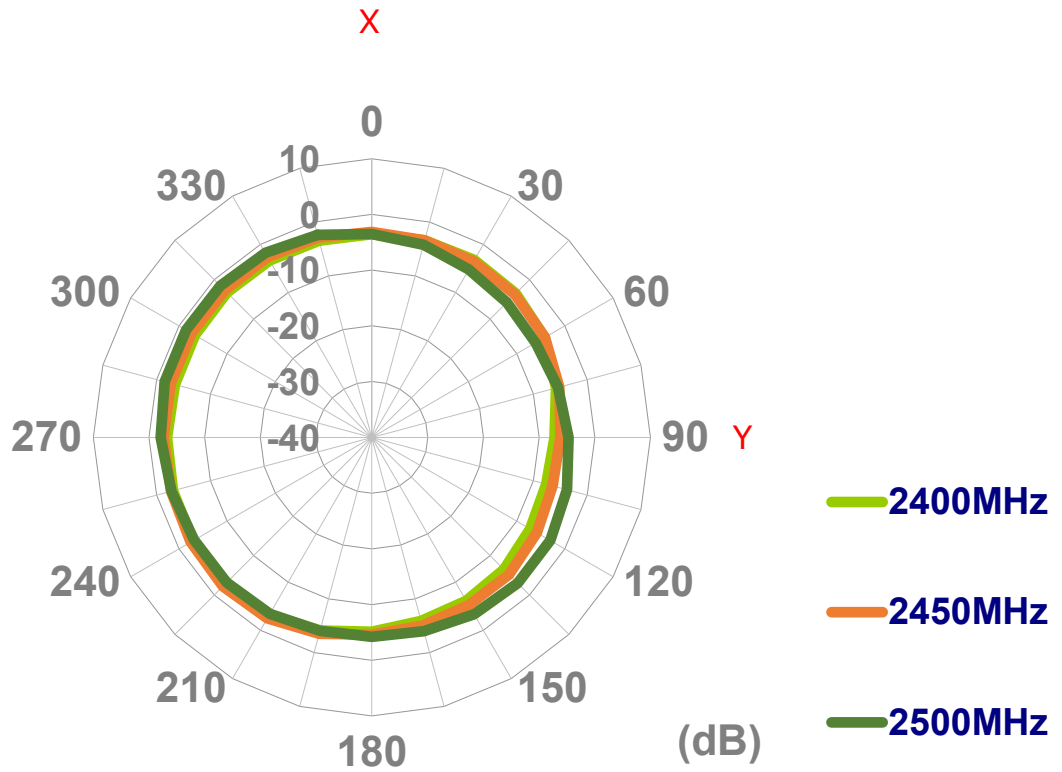

XZ Plane

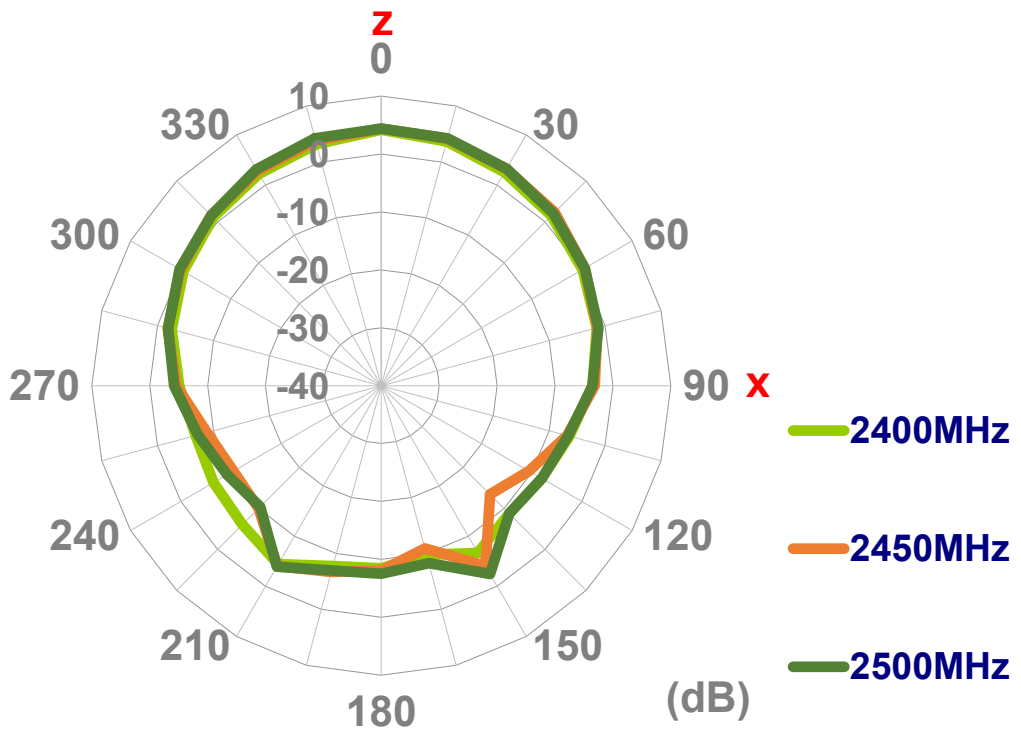

YZ Plane

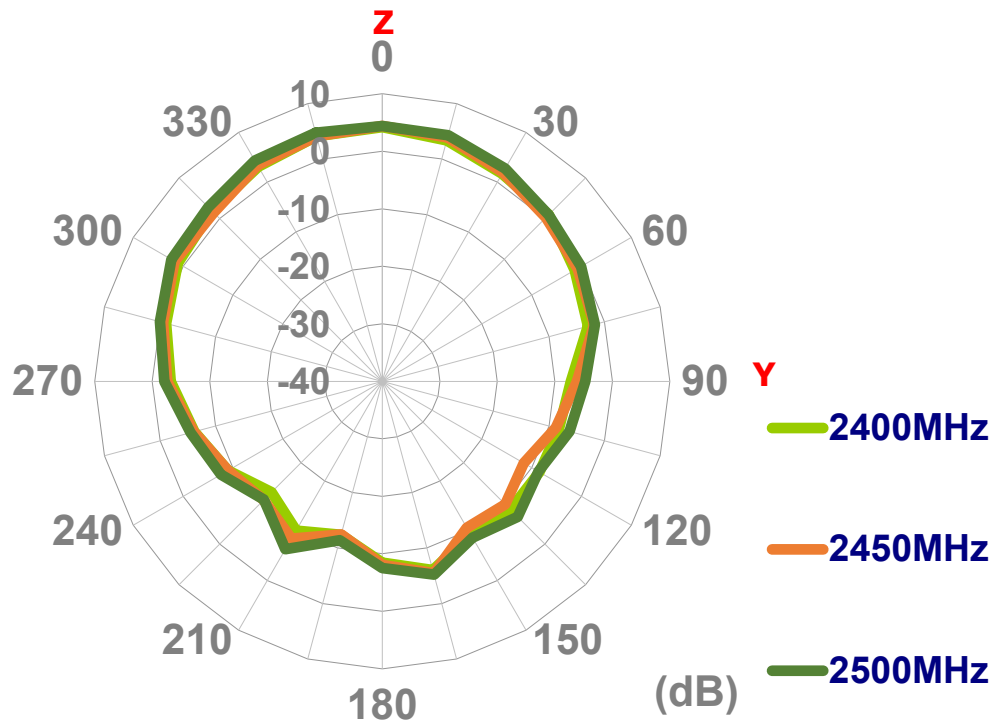

3.4 Efficiency

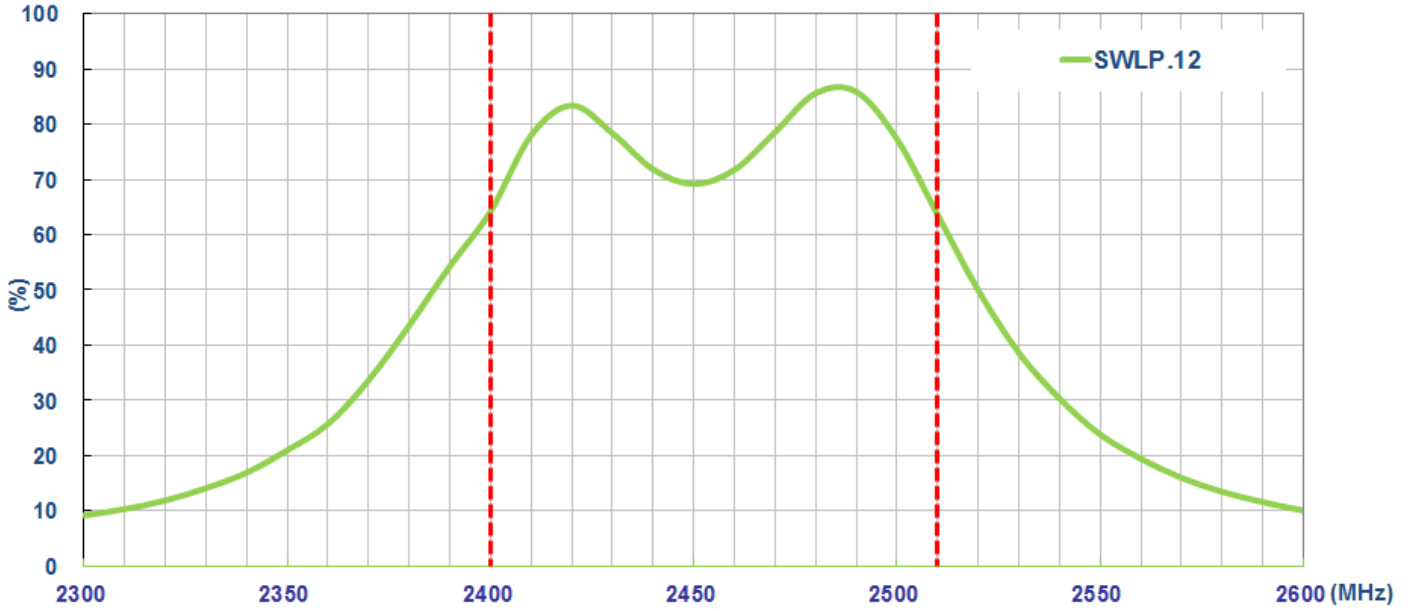

3.5 Average Gain

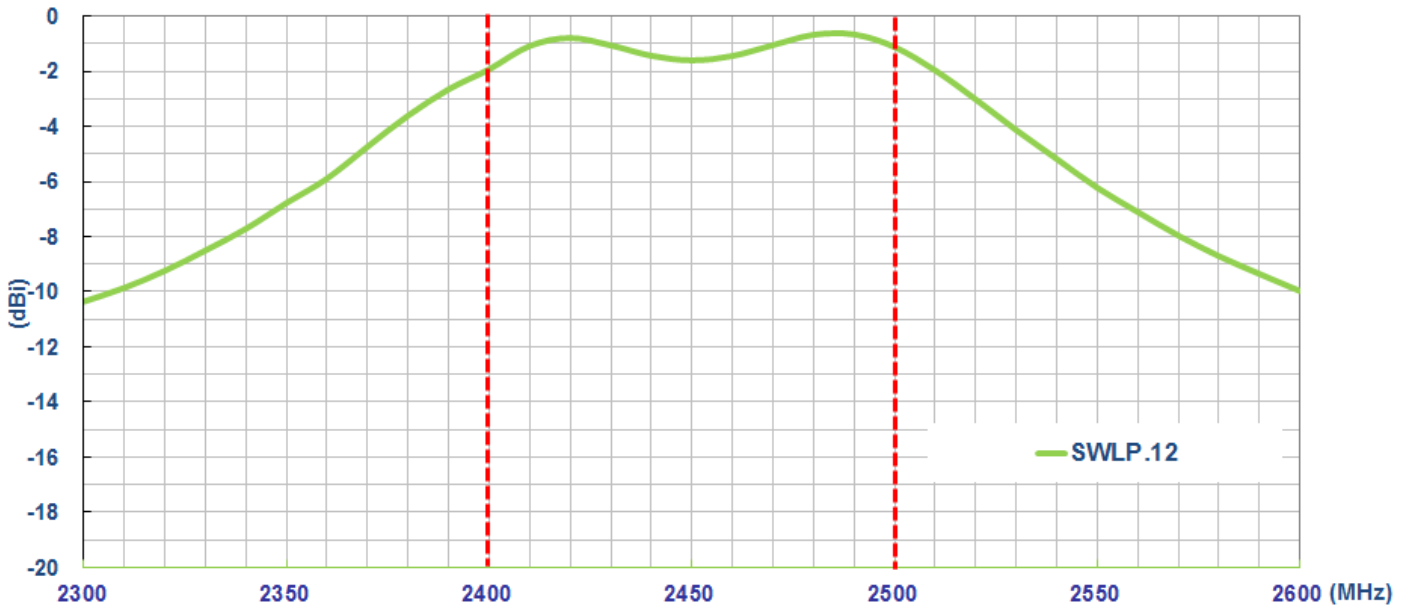

3.6 Peak Gain

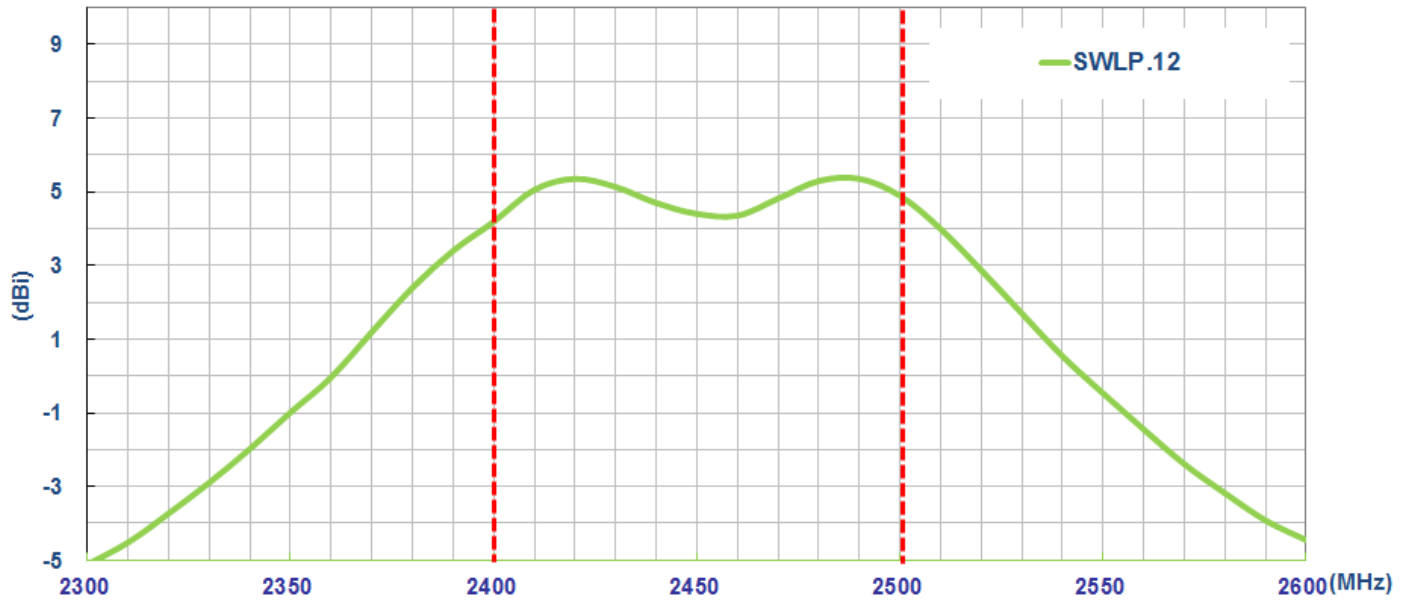

3.7 3D Radiation Pattern

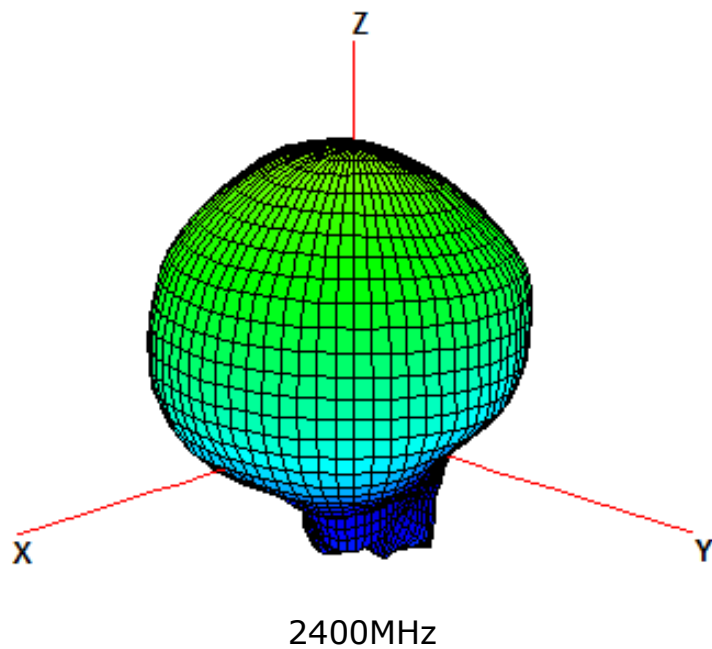

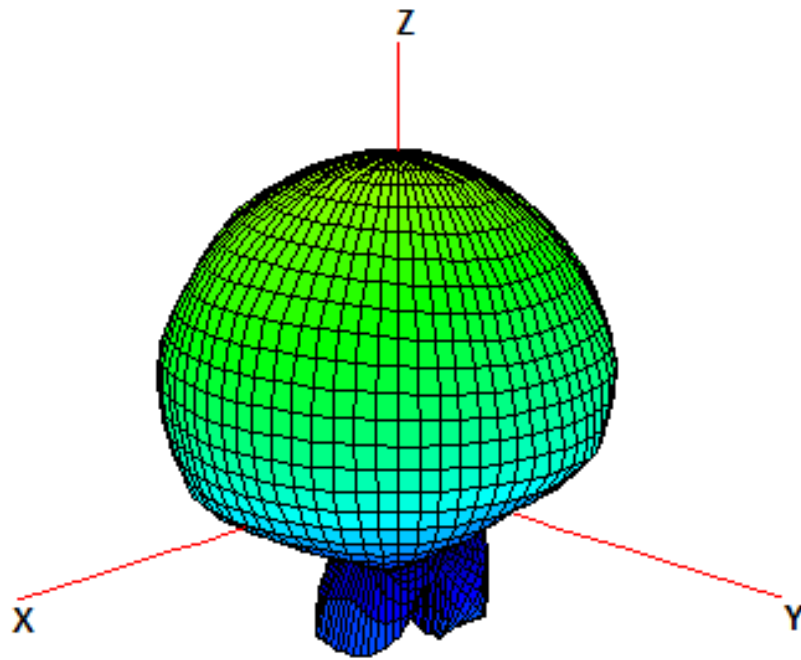

2450MHz

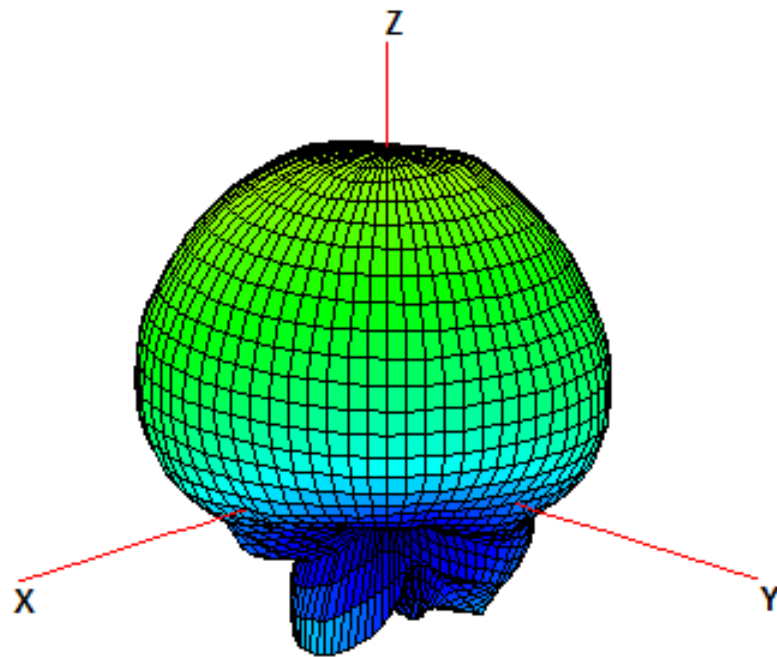

2500MHz

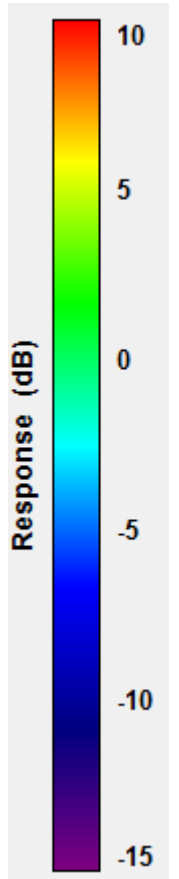

4. Dimensions

Top View

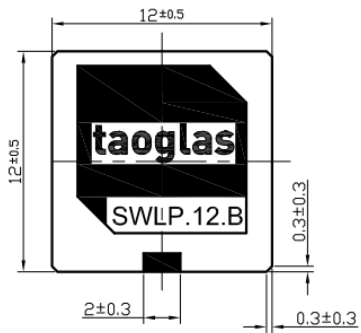

Side View

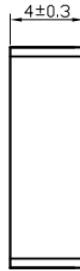

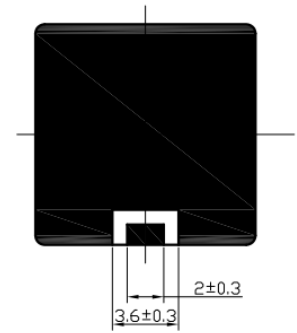

Bottom View

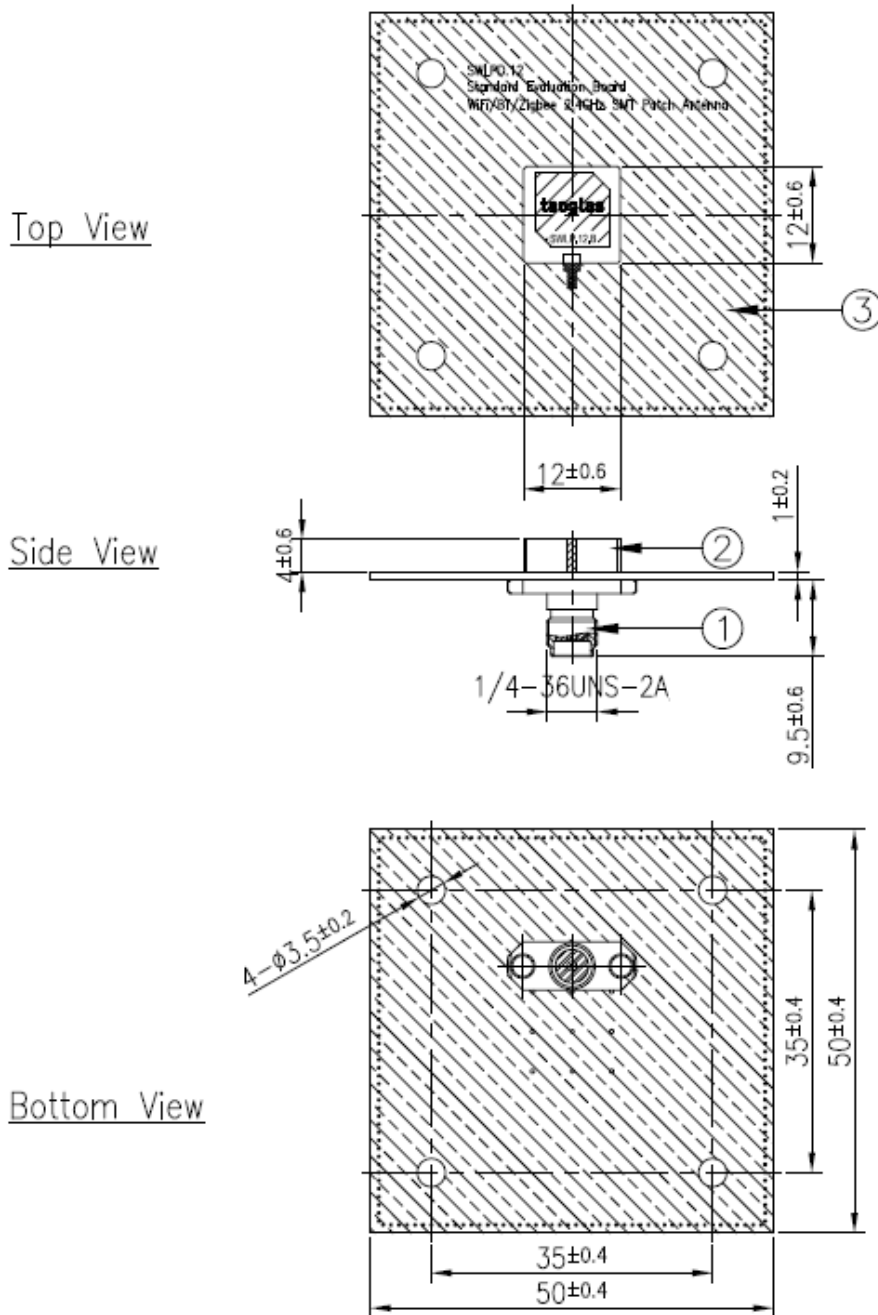

4.1 Evaluation Board Dimensions



Notes

- 1. Silver area 
- 2. Copper area 
- 3. Solder mask 

	Name	P/N	Material	Finish	QTY
1	PCB SMA(F) ST	200417B000000A	Brass	Au Plated	1
2	SWLP.12 Patch (12x12x4mm)	001517B030000A	Ceramic	Clear	1
3	SWLPD.12 PCB (50x50x1mm)	100217B010000A	Composite 1.0t	N/A	1

5. Footprint

5.1 Top Copper

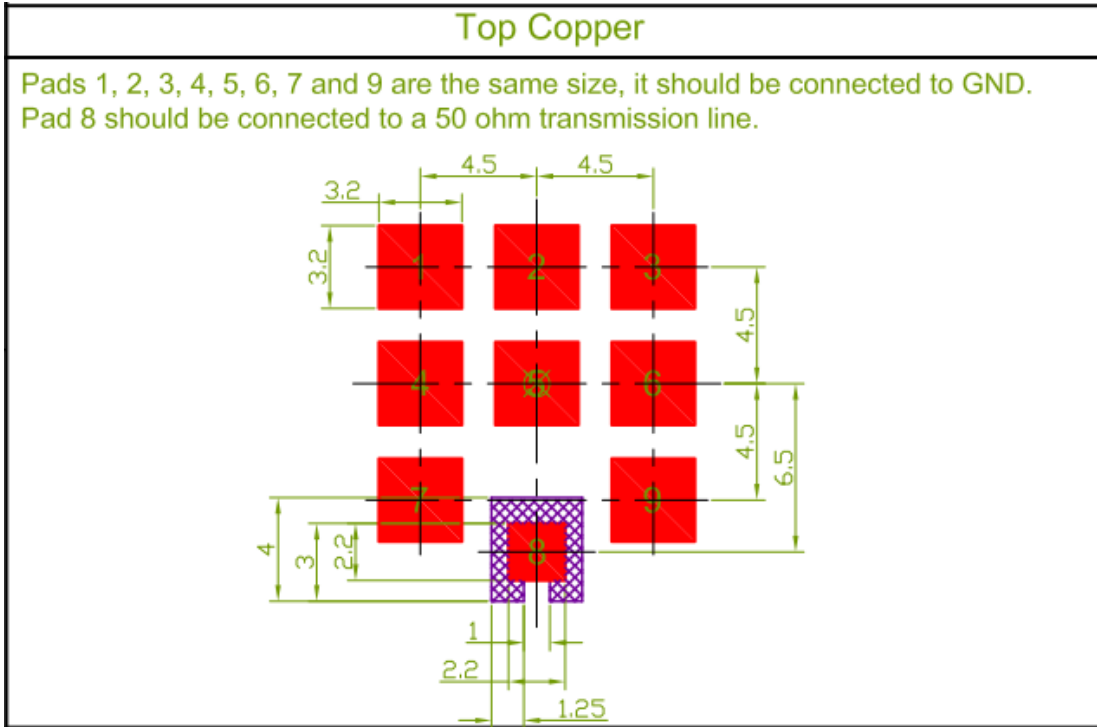

5.2 Top Solder paste

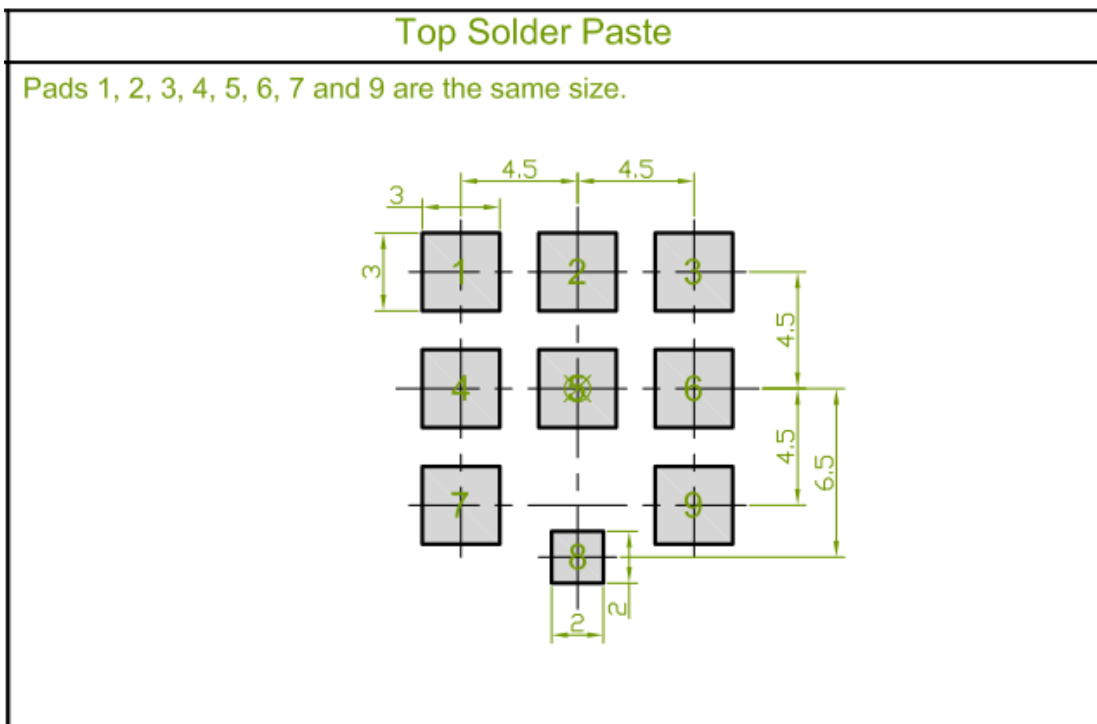

5.3 Top Solder Mask

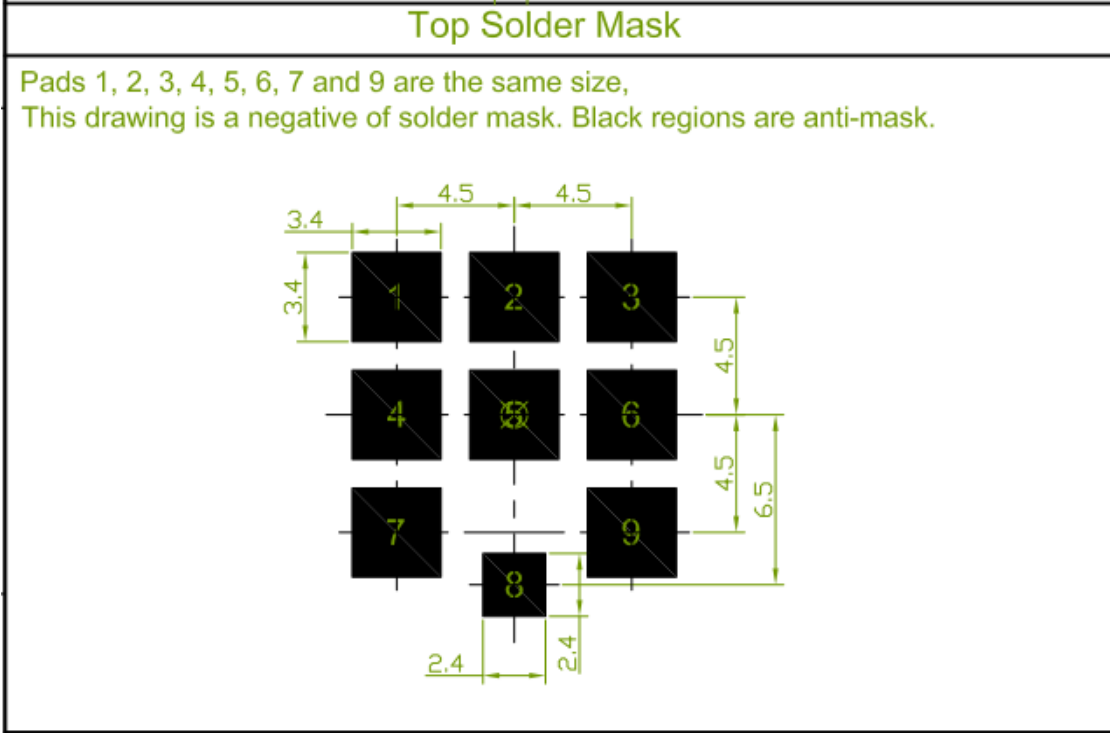

5.4 Composite Diagram

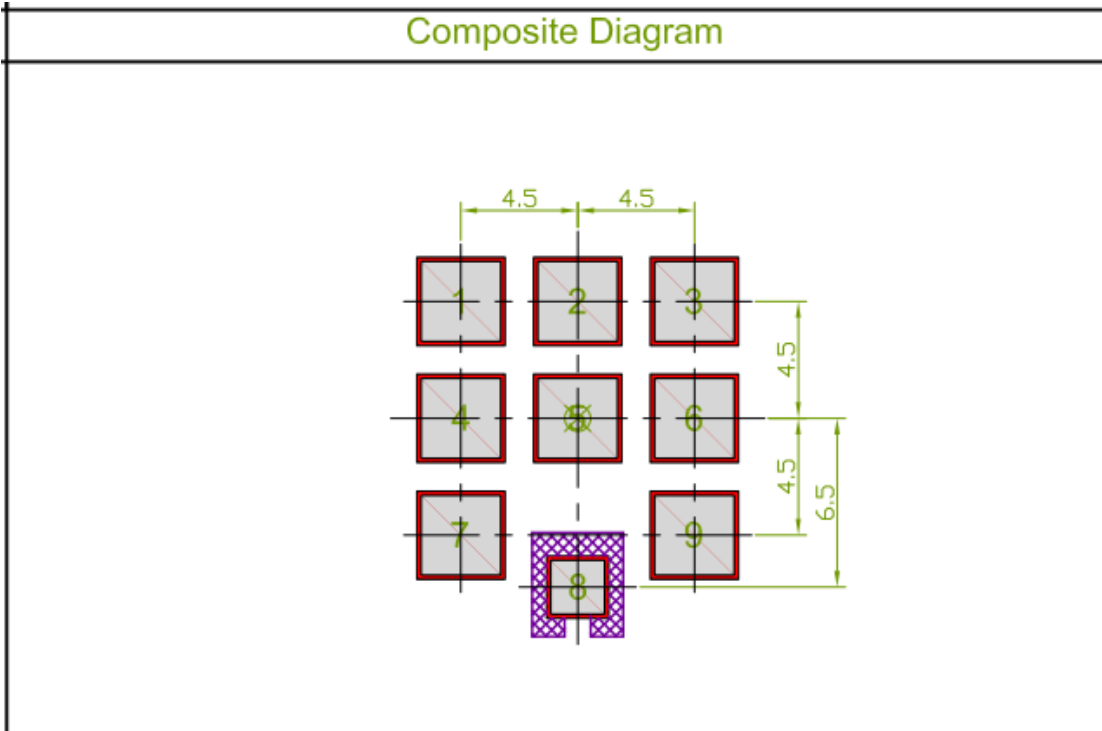

6. Packaging

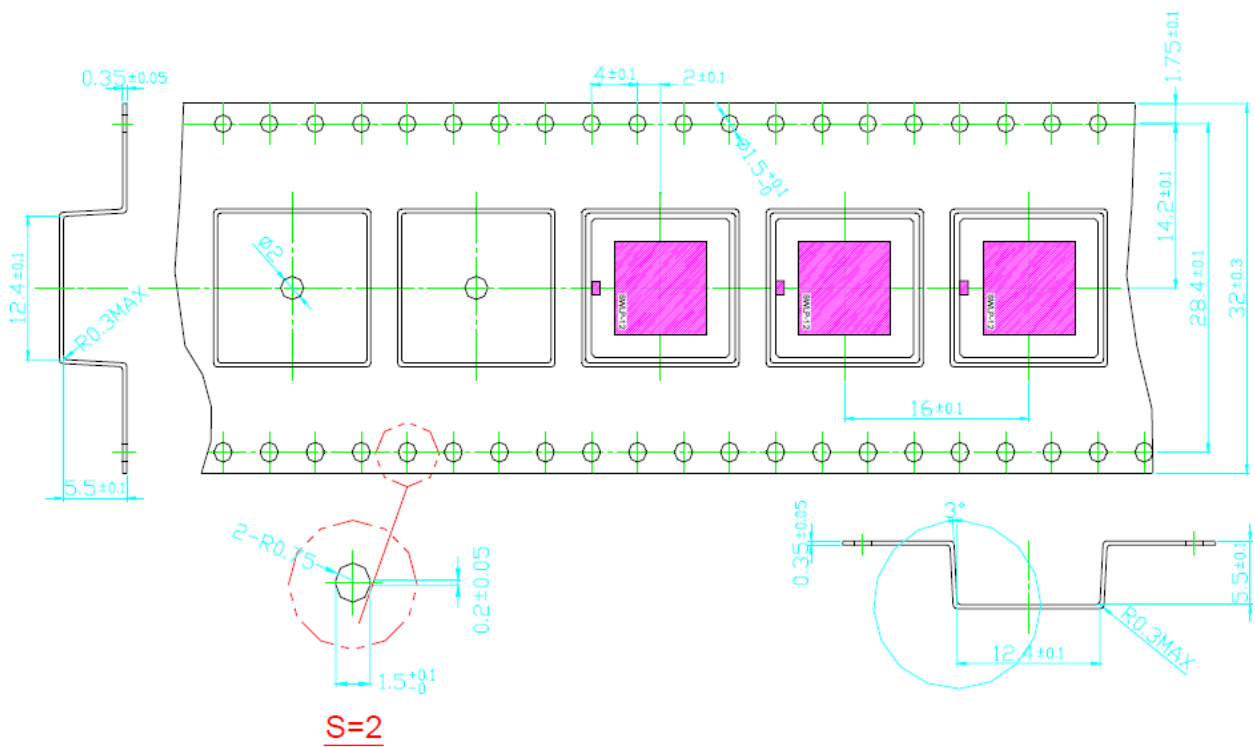
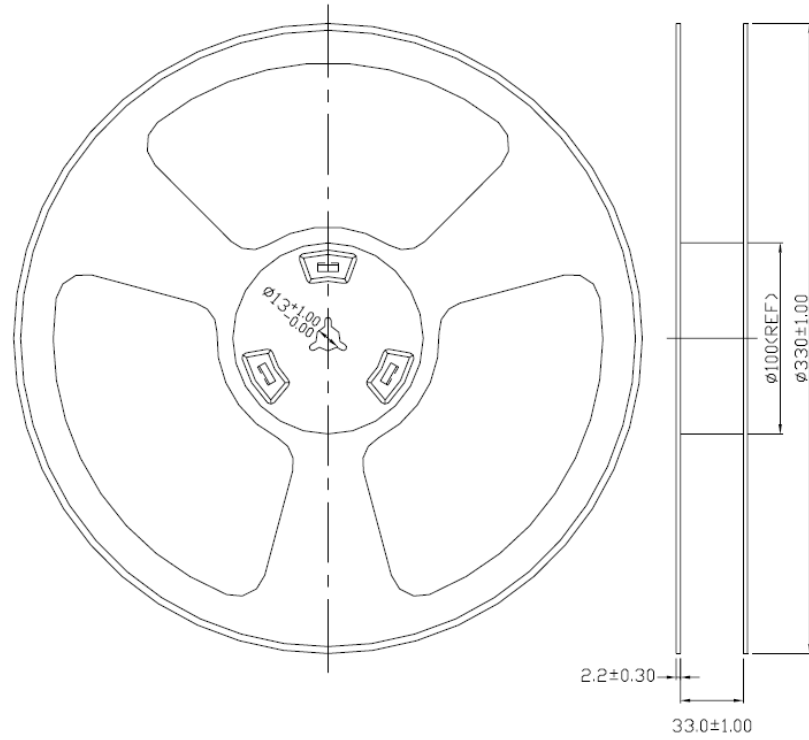

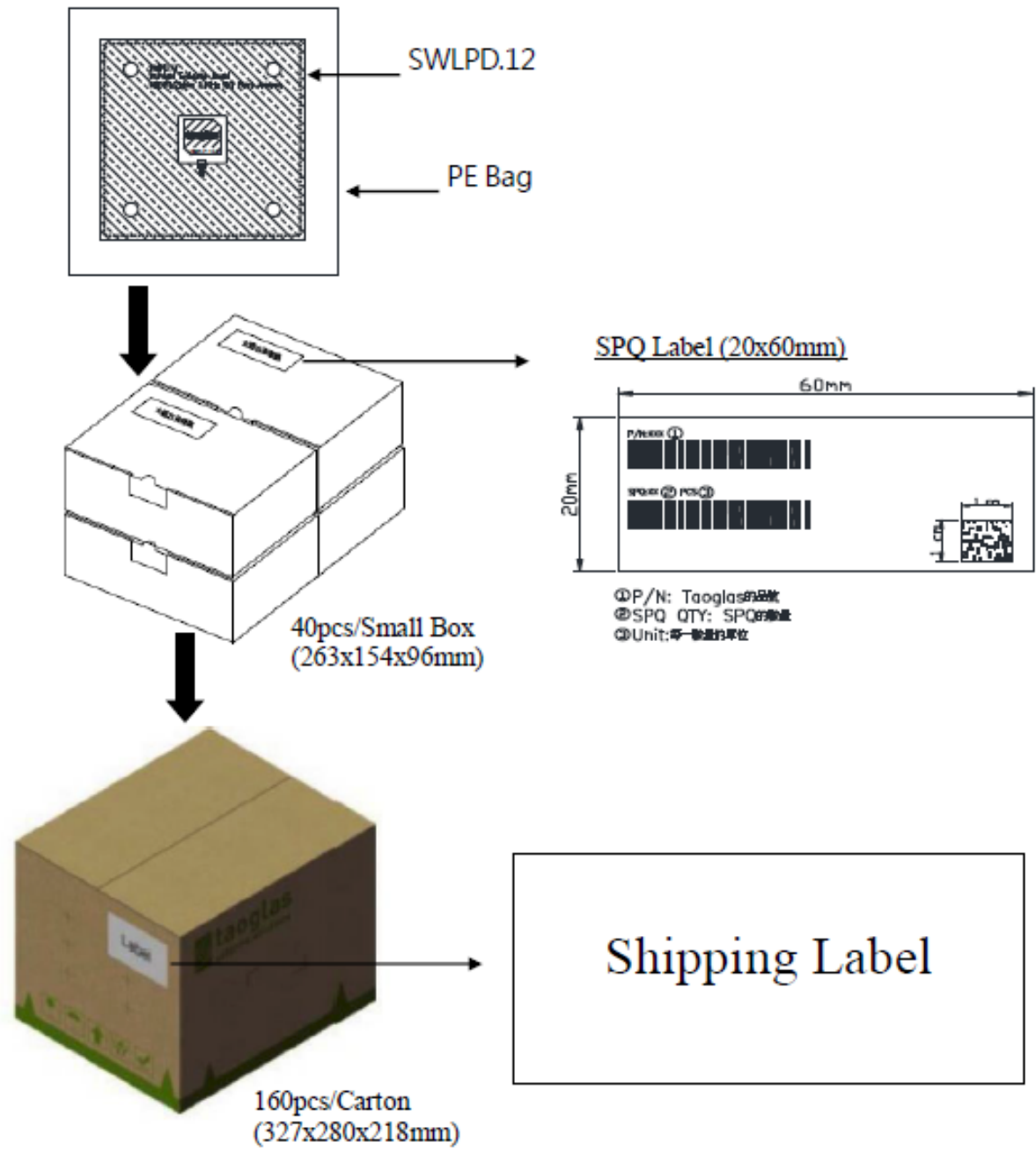

7. Recommended Reflow Temperature Profile

SWLP.12B can be assembled following Pb-free assembly. According to the Standard IPC/JEDEC J-STD-020C, the temperature profile suggested is as follow:

Phase	Profile Features	Pb-Free Assembly (SnAgCu)
PREHEAT	Temperature Min(T_{smin})	150°C
	Temperature Max(T_{smax})	200°C
	Time(t_s) from (T_{smin} to T_{smax})	60-120 seconds
RAMP-UP	Avg. Ramp-up Rate (T_{smax} to TP)	3°C/second(max)
REFLOW	Temperature(T_L)	217°C
	Total Time above T_L (t_L)	30-100 seconds
PEAK	Temperature(T_P)	260°C
	Time(t_p)	2-5 seconds
RAMP-DOWN	Rate	3°C/second(max)
Time from 25°C to Peak Temperature		8 minutes max.
Composition of solder paste		96.5Sn/3Ag/0.5Cu
Solder Paste Model		SHENMAO PF606-P26

The graphic shows temperature profile for component assembly process in reflow ovens

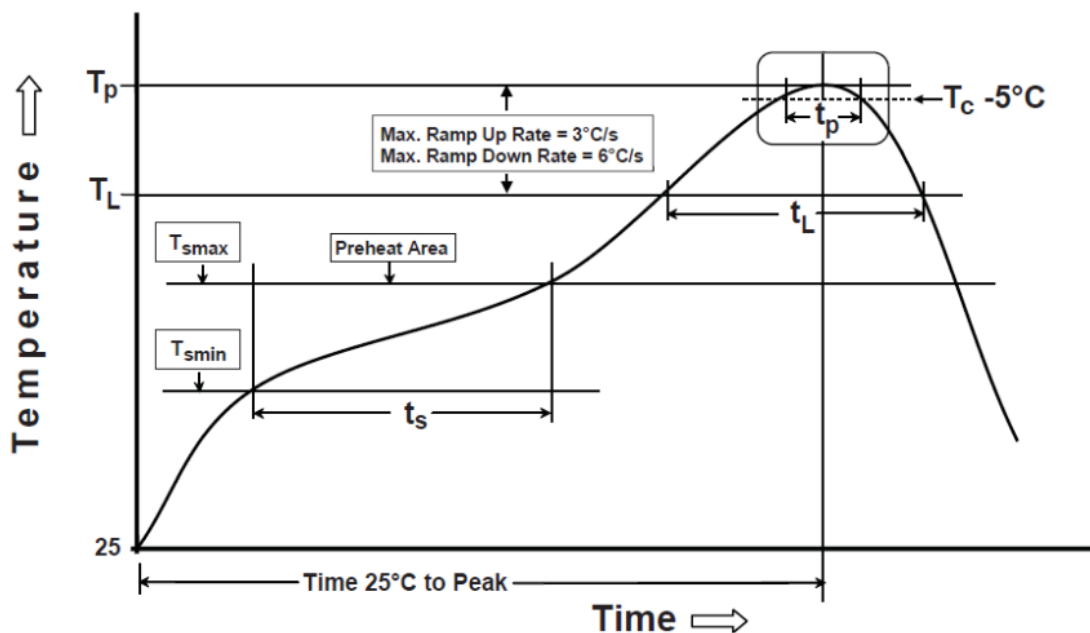

Soldering Iron condition: Soldering iron temperature 270°C±10°C.

Apply preheating at 120°C for 2-3 minutes. Finish soldering for each terminal within 3 seconds, if soldering iron temperature over 270°C±10°C or 3 seconds, it will make cause component surface peeling or damage.

Taoglas makes no warranties based on the accuracy or completeness of the contents of this document and reserves the right to make changes to specifications and product descriptions at any time without notice.

Taoglas reserves all rights to this document and the information contained herein.

Reproduction, use or disclosure to third parties without express permission is strictly prohibited.

Copyright © Taoglas Ltd.

X-ON Electronics

Largest Supplier of Electrical and Electronic Components

Click to view similar products for [Antennas](#) category:

Click to view products by [Taoglas](#) manufacturer:

Other Similar products are found below :

[GAN30084EU](#) [930-033-R](#) [GW17.07.0250E](#) [1513563-1](#) [EXE902SM](#) [APAMPG-117](#) [MAF94383](#) [W3908B0100](#) [W6102B0100](#) [YE572113-30RSMM](#) [108-00014-50](#) [66089-2406](#) [SPDA17RP918](#) [A09-F8NF-M](#) [A09-F5NF-M](#) [RGFRA1903041A1T](#) [W3593B0100](#) [W3921B0100](#) [SIMNA-868](#) [SIMNA-915](#) [SIMNA-433](#) [W1044](#) [W1049B090](#) [A75-001](#) [WTL2449CQ1-FRSMM](#) [CPL9C](#) [EXB148BN](#) [0600-00060](#) [TRA9020S3PBN-001](#) [GD5W-28P-NF](#) [MA9-7N](#) [GD53-25](#) [GD5W-21P-NF](#) [C37](#) [MAF94051](#) [MA9-5N](#) [EXD420PL](#) [B1322NR](#) [QWFTB120](#) [MAF94271](#) [MAF94300](#) [GPSMB301](#) [FG4403](#) [AO-AGSM-OM54](#) [5200232](#) [MIKROE-2349](#) [WCM.01.0111](#) [MIKROE-2393](#) [MIKROE-2352](#) [MIKROE-2350](#)