

# Specification

## Patent Pending

**Part No.** : **Accura UWCCP.01**

**Description** : 6~7 GHz Ultra-Wideband (UWB)  
Embedded Circular Polarized  
SMT Chip Antenna

**Features** : SMD UWB Chip Antenna  
For European and USA UWB Applications  
In Channels 5

### Uses

- Centimeter Level Positioning
- Indoor Positioning
- Follow Me Autonomous Positioning
- Time of Arrival (TOA) Applications
- Angle of Arrival (AOA) Applications
- Remote Keyless Entry (RKE) Security

Frequency: 6.0 – 7.0 GHz

Dims: 14.3mm\*8.35mm\*2mm

RoHS compliant



Actual Size



## 1. Introduction

The UWCCP.01 chip antenna, at 14.3\*8.35\*2 mm, is a small form factor embedded Ultra-Wideband (UWB) antenna with high efficiencies across the pulsed UWB communications operational channel 5 (6.25 GHz – 6.75 GHz). It is circularly polarized and hence very suitable for use in mobile tags in standard Time of Arrival (ToA) and advanced Angle of Arrival (AoA) localization systems. It is mounted to a PCB via standard SMT reflow process.

The UWCCP.01 antenna is a durable ceramic antenna that has a peak gain of 6.5dBi, an efficiency of more than 70% across the channel 5 and is designed to be mounted directly onto a PCB. It is an ideal choice for any device maker that needs to keep manufacturing costs down over the lifetime of a product. Like all such antennas, care should be taken to mount the antenna at least 3mm from metal components or surfaces, and ideally 5mm for best radiation efficiency.

Ultra-Wideband (also known as UWB) is a low power digital wireless technology for transmitting large amounts of digital data over a wide spectrum of frequency bands typically spanning more than 500MHz with very low power for short distances. The low power requirements of UWB mean increased battery life of sensors and tags leading to reduction in overall operational costs.

Besides the chip antenna line, Taoglas has also developed innovative and new-to-market flexible embedded UWB antennas designed for seamless integration on plastics and using highly flexible micro-coaxial cable mounting while achieving high performance where space is limited. Taoglas UWB antennas have been designed for use with the recently launched Decawave ScenSor DW1000 module and are also compatible with any other UWB sensor modules on the market.

## 1.1. Applications of Pulsed UWB antenna Technology

- **Radar** - These short-pulsed antennas provide very fine range resolution and precision distance and positioning measurement capabilities. UWB signals enable inexpensive high definition radar antennas which find use in automotive sensors, smart airbags and precision surveying applications amongst many others.
- **Home Network Connectivity** - Smart home and entertainment systems can take advantage of high data rates for streaming high quality audio and video contents in real time for consumer electronics and computing within a home environment.
- **Position location & Tracking** - UWB antennas also find use in Position Location and Tracking applications such as locating patients in case of critical condition, hikers injured in remote areas, tracking cars, and managing a variety of goods in a big shopping mall. UWB offers better noise immunity and better accuracy to within a few cm compared to current localization technologies such as Assisted GPS for Indoors, Wi-Fi and cellular which are at best able to offer meter level precision. Tethered Indoor Positioning UWB systems that measure the angles of arrival of ultra-wideband (UWB) radio signals perform triangulation by using multiple sensors to communicate with a tag device.

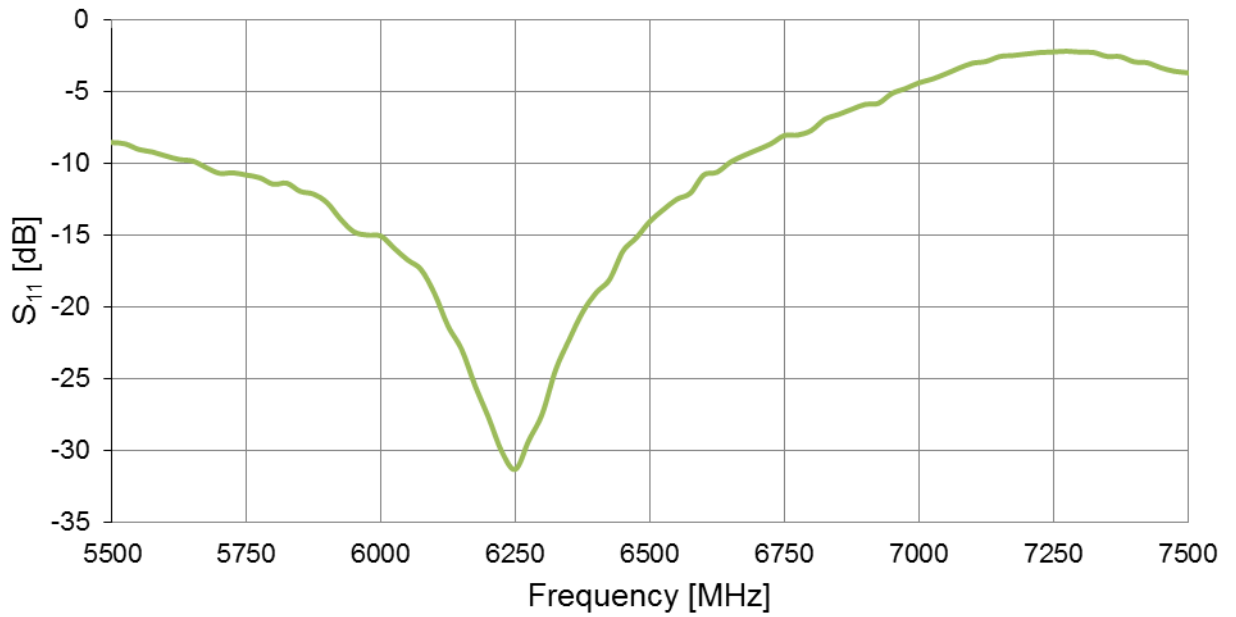
## 2. Specification

Electrical	
STANDARD	EU UWB
	USA UWB Channel 5
Operation Frequency (GHz)	6.24-6.74
Return Loss (dB)	< -8
Efficiency (%)	80
Peak Gain (dBi)	6.5
Max Axial Ratio (dB)	6
Radiation Properties	Omnidirectional
Polarization	Circular
Impedance (Ohms)	50
Max input Power (Watts)	10
Mechanical	
Dimension	14.8*8.4*2mm
Material	Ceramic
Environmental	
Operation Temperature	-40°C to 85°C
Storage Temperature	-40°C to 85°C
Humidity	40% to 90%

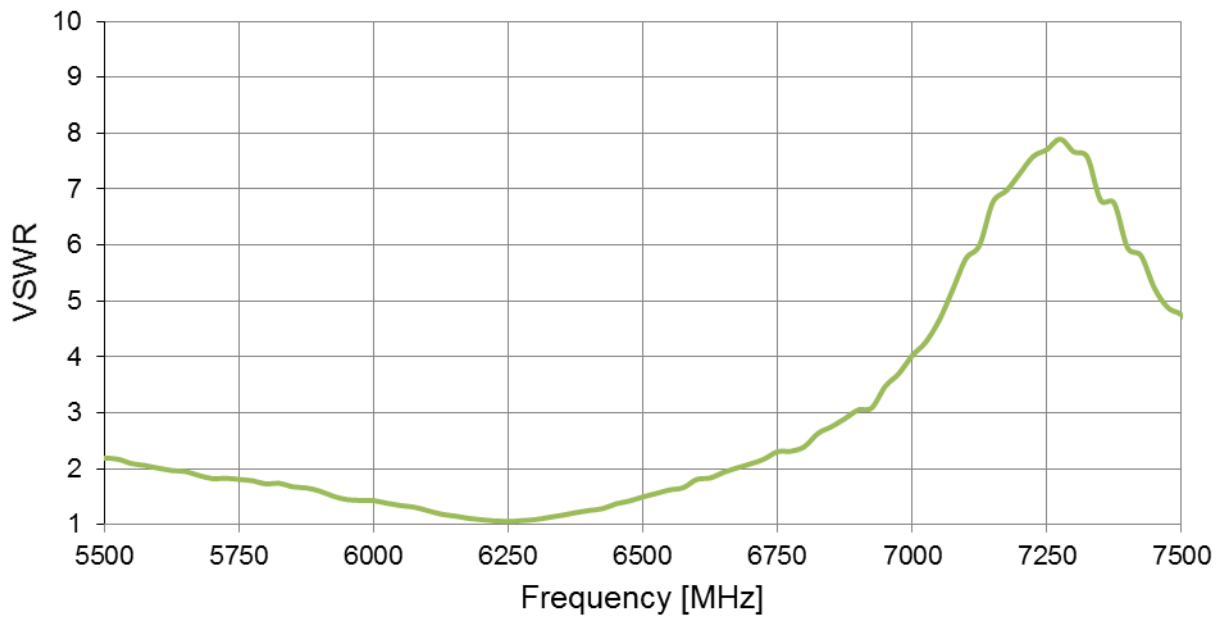
\* Results obtained for antenna on Standard Evaluation Board size 16 mm x 12 mm, with 16 mm x 4.2 mm ground plane.

### 3. Antenna Characteristics

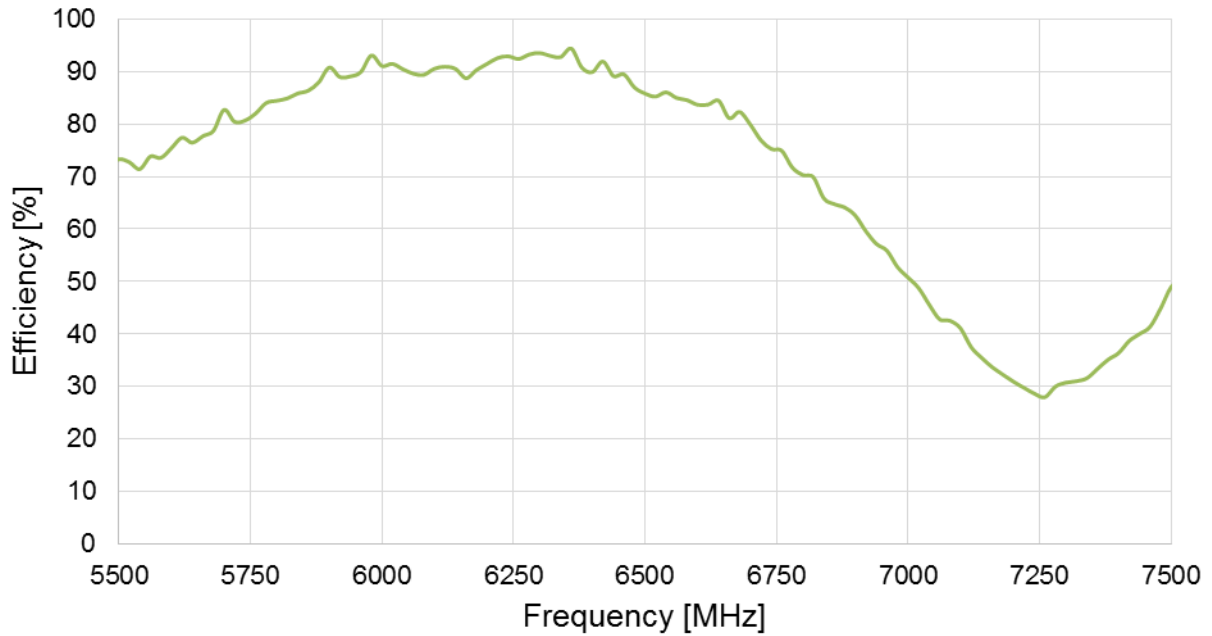
#### 2.1 Return Loss



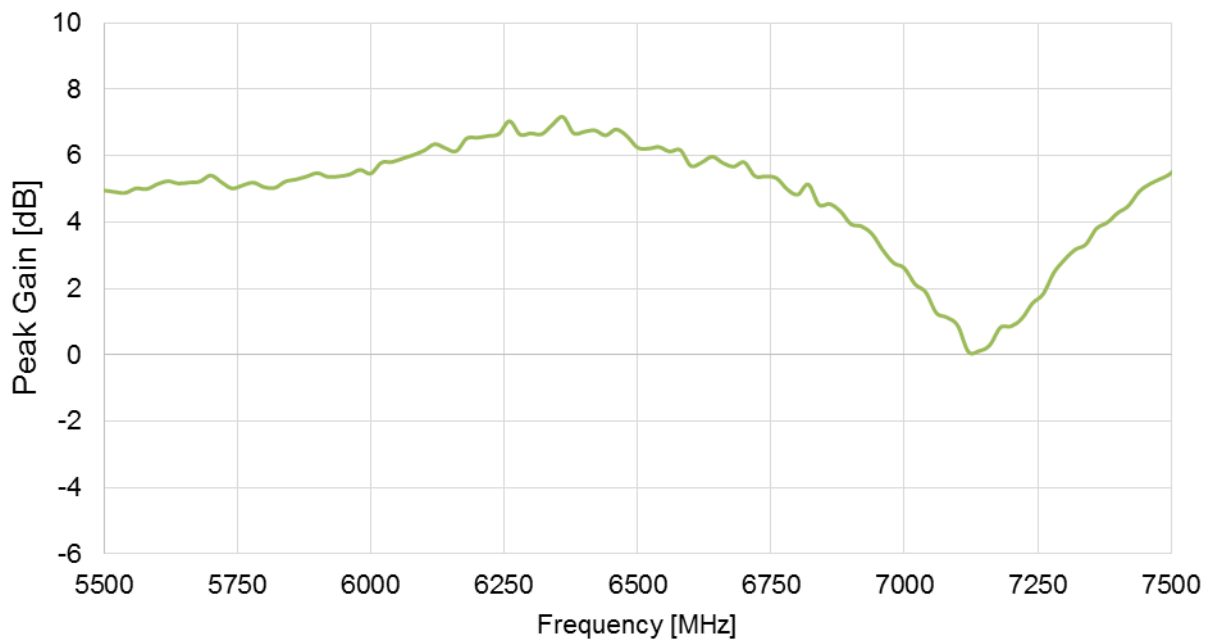
#### 2.2 VSWR



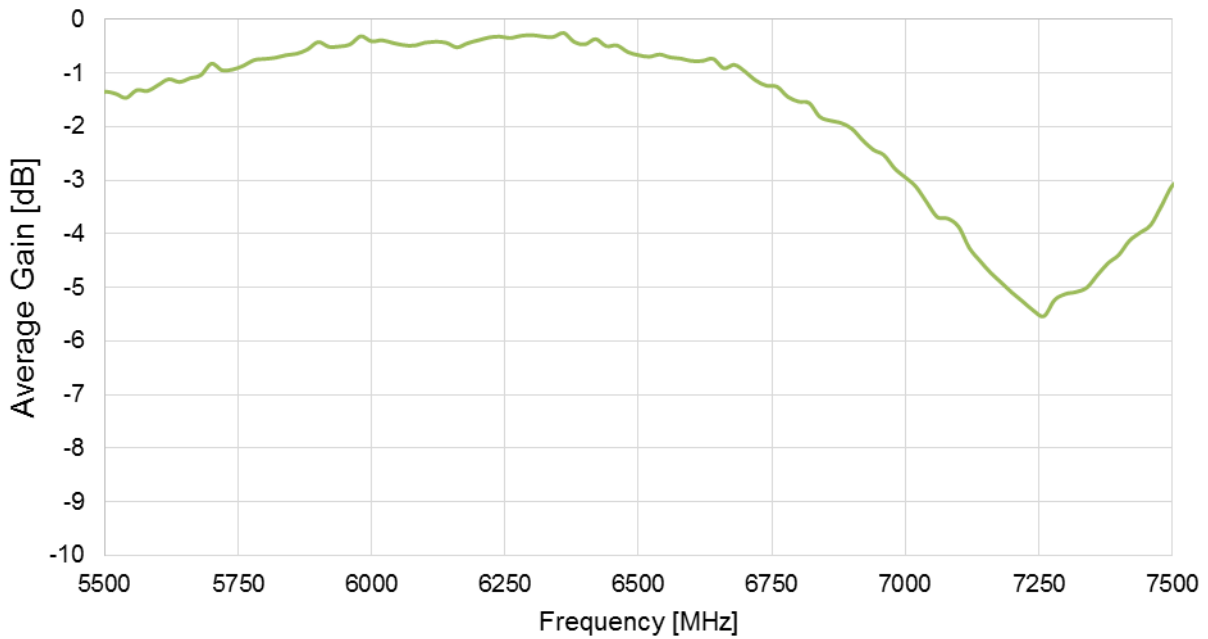
### 2.3 Efficiency



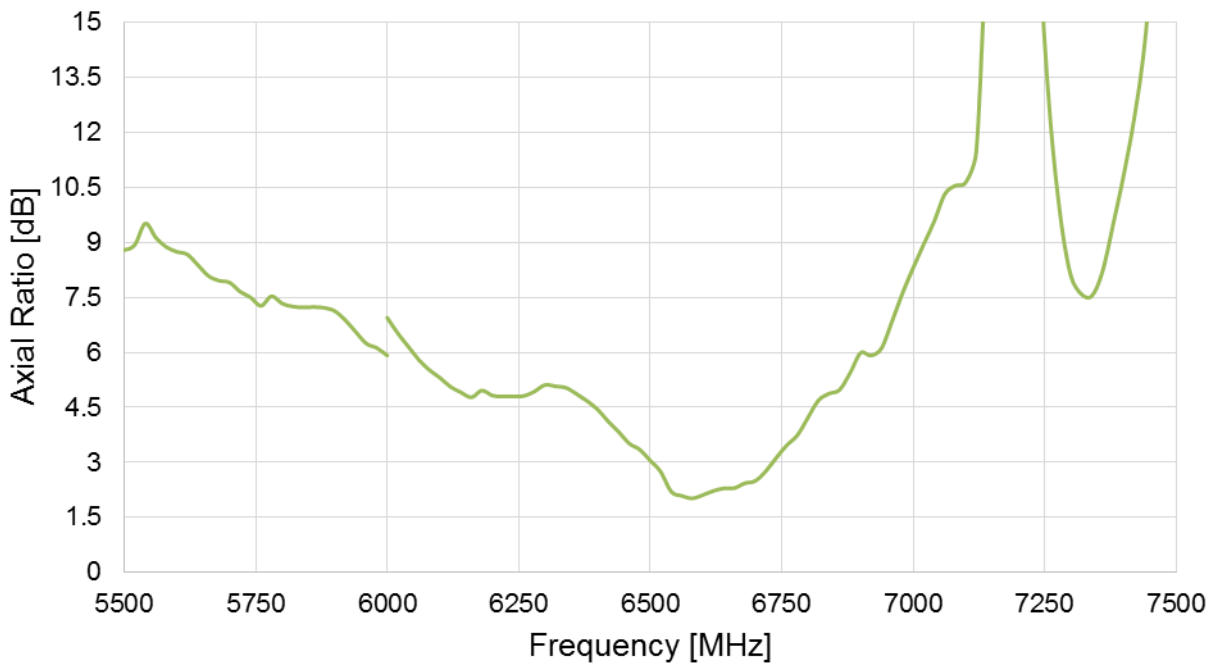
### 2.4 Peak Gain



## 2.5 Average Gain



## 2.6 Axial Ratio\*



\*Note:

Axial ratio measurements are done with 2 different physical systems (< 6 GHz and > 6 GHz) therefore a discontinuity appears at 6 GHz

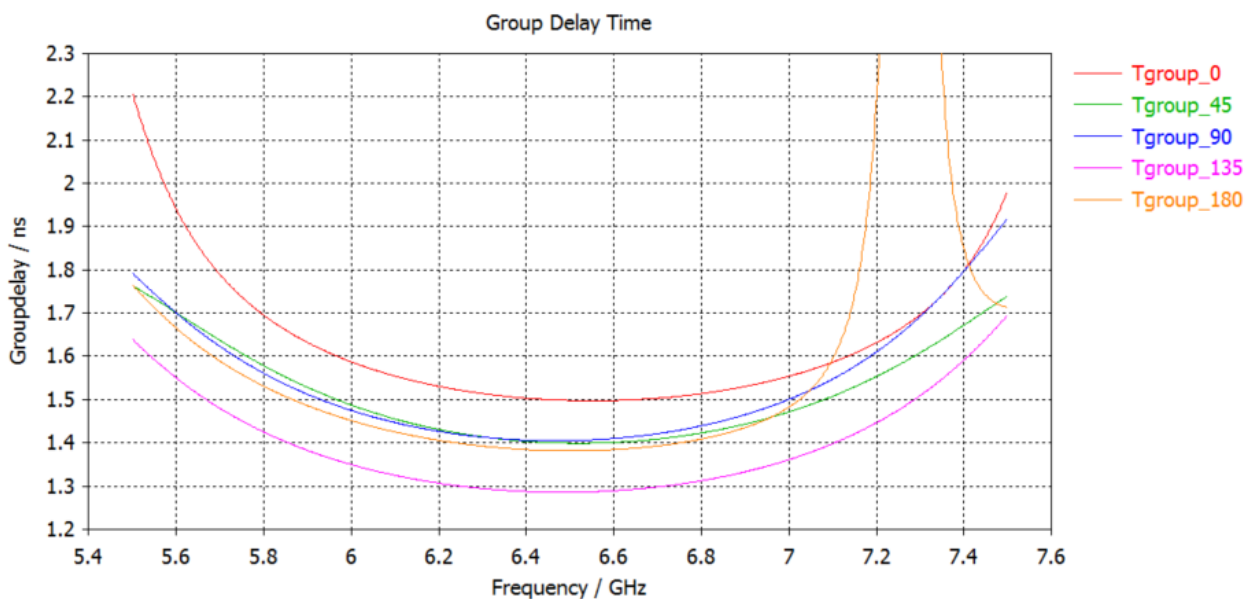
## 2.7 Group Delay (XY Plane) at 6.5GHz

The Total System Group Delay (in seconds) is the total time delay or transmit time of the amplitude envelopes of the various sinusoidal components of UWB signals through a device or link budget system. Effectively it is the propagation delay in transmitting antenna (Tx), propagation channel (Ch), and in receiving antenna (Rx) summed together.

An even more important parameter is the Group Delay Variation over Theta Angle from an average constant group delay. The group delay ripple is used to quantify this deviation. Ultimately, deviations from a maximally flat or constant group delay represent distortions in the output signal which is undesirable. A group delay variation of 100-150ps or less is considered very good for UWB system implementation.

### 2.7.1 Group Delay Vs Frequency

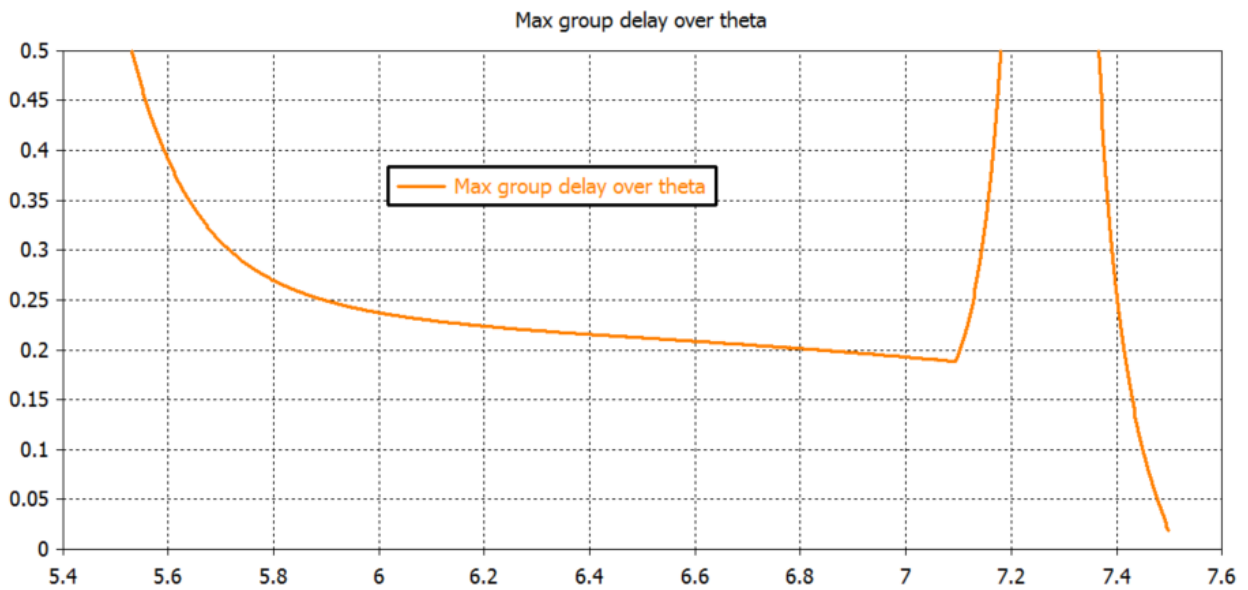
The group delay was simulated for two antennas placed at a far-field distance of 1m distance. One of the antennas was kept stationary, while the other was rotated in 45° intervals.





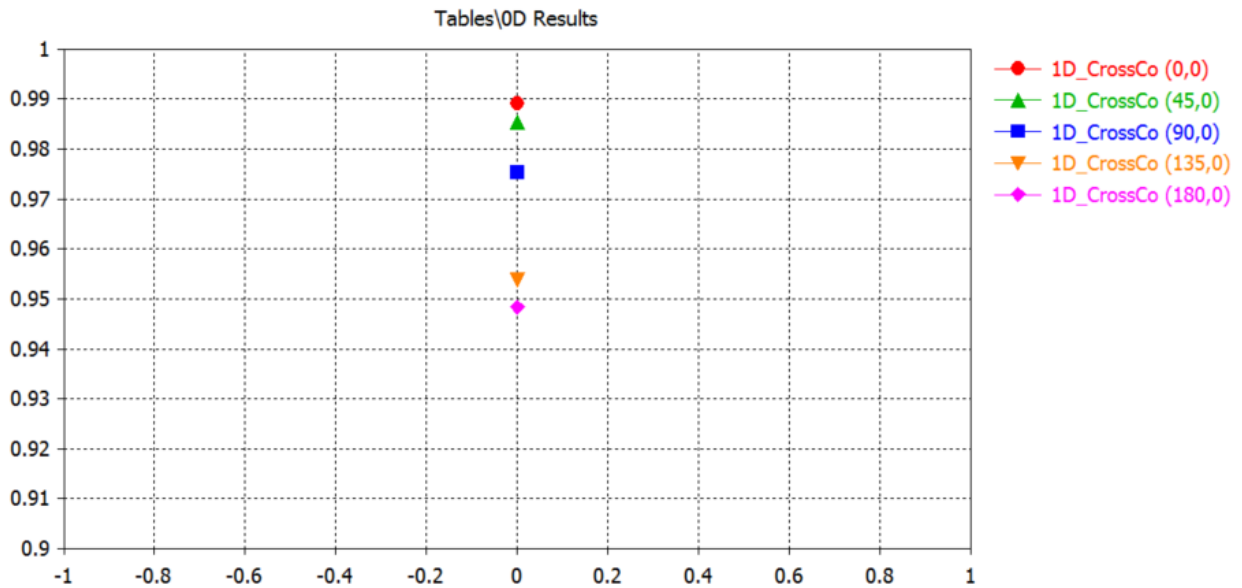
### 2.7.2 Group Delay Vs Theta at 6.5 GHz

The calculated Maximum difference between the highest value and the lowest Group Delay value is presented below. The UWCCP.01 antenna presents Group Delay variation smaller than 250 ps (slightly above benchmark but flat) from 6 GHz up to 7.1 GHz spanning UWB channels 5-7.



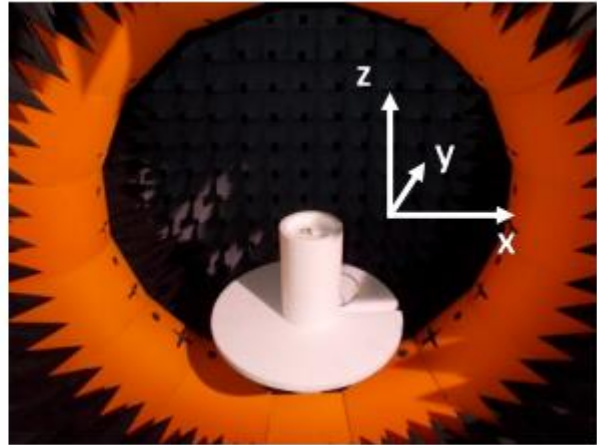
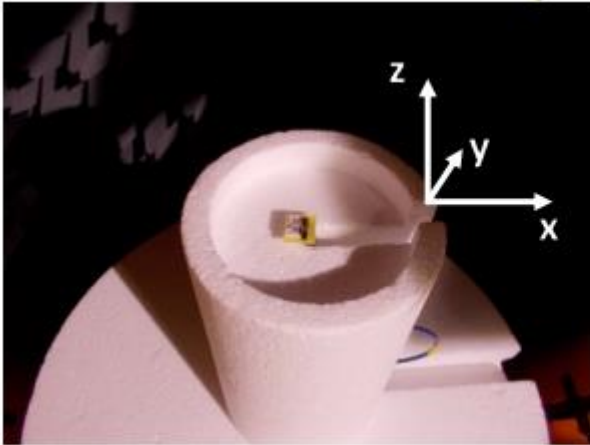
## 2.8 Fidelity Factor vs. Theta Angle

The fidelity is above 0.9 (benchmark value) for all Theta angles, therefore UWCCP.01 shows very good performance.



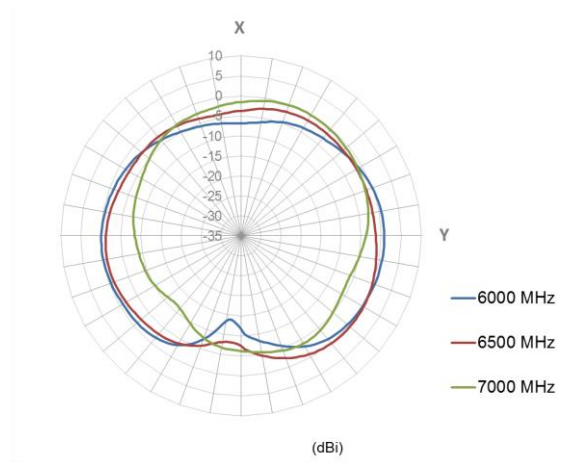
## 3. Antenna Radiation Pattern

### 3.1 Measurement Setup

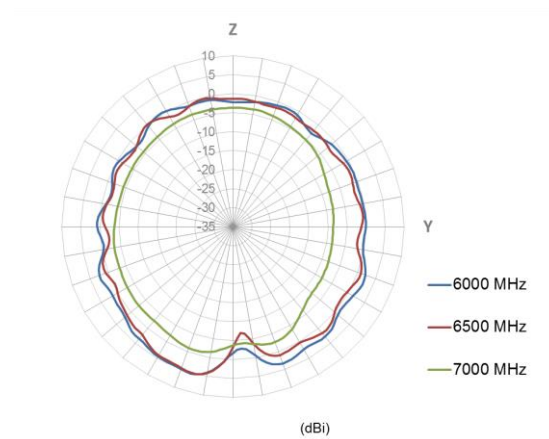


## 3.2 2D Radiation Pattern (dBi)

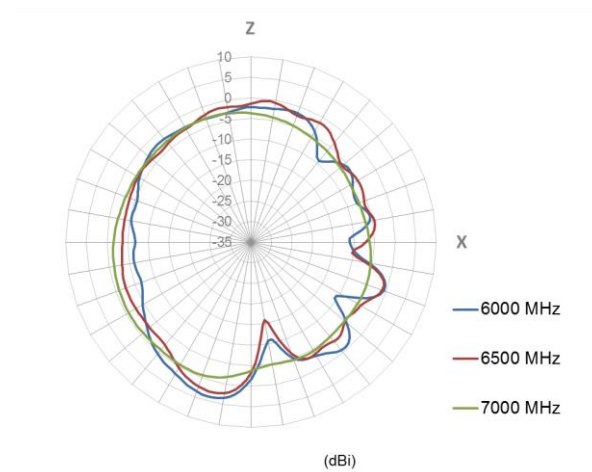
### 3.2.1 XY Plane



### 3.2.2 YZ Plane

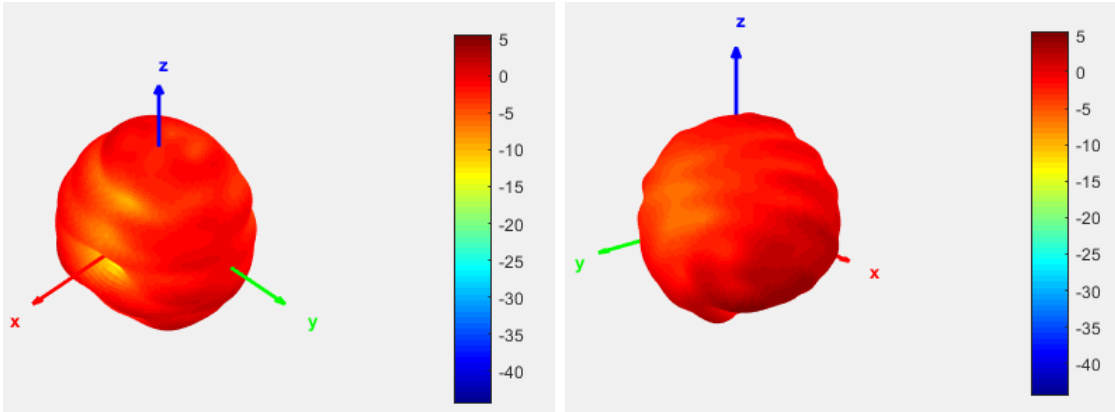


### 3.2.3 XZ Plane

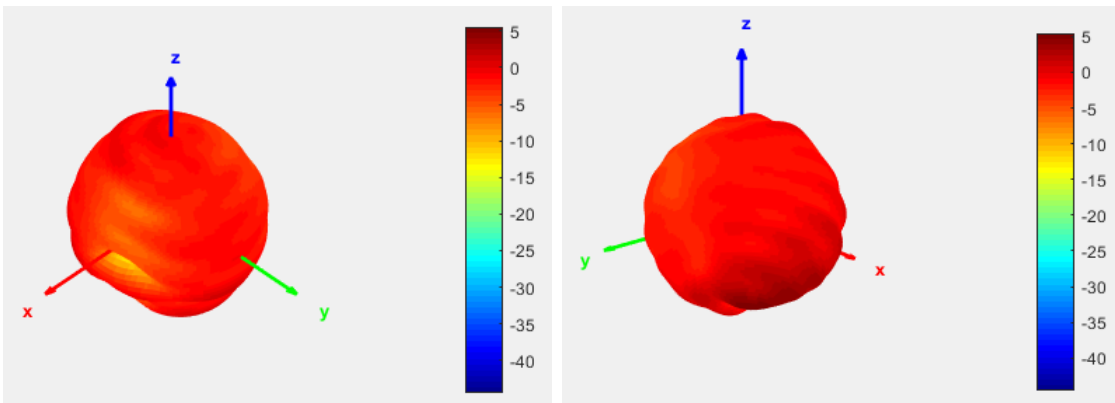


### 3.3 3D Radiation Pattern (dBi)

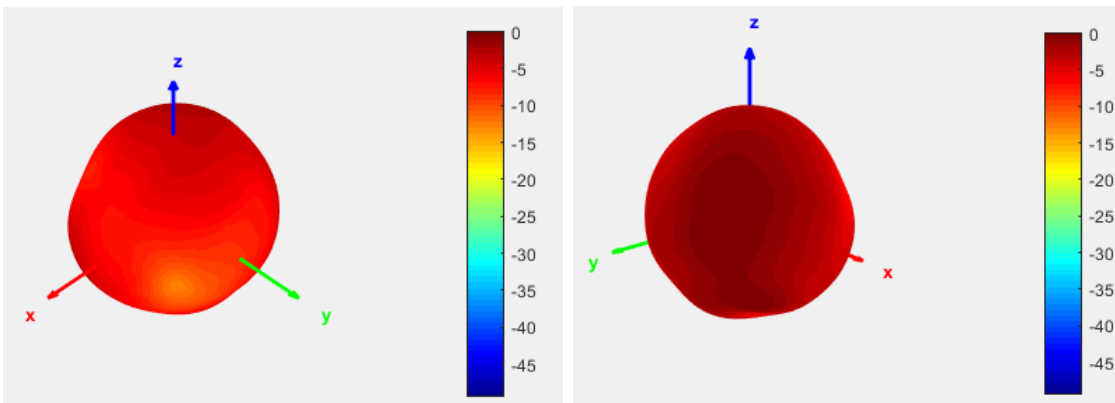
#### 3.3.1 6GHz



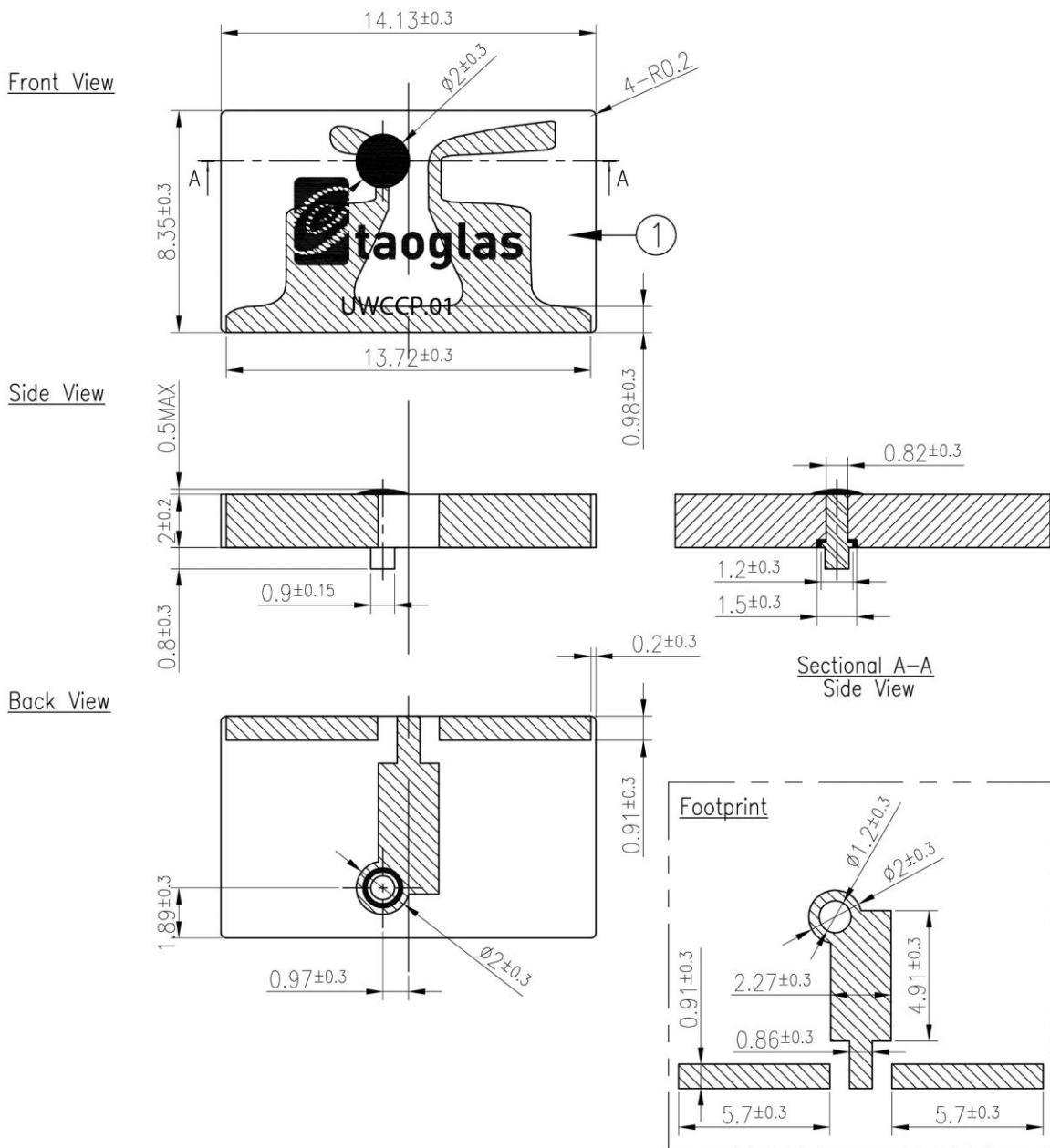
#### 3.3.2 6.5GHz



#### 3.3.2 7GHz



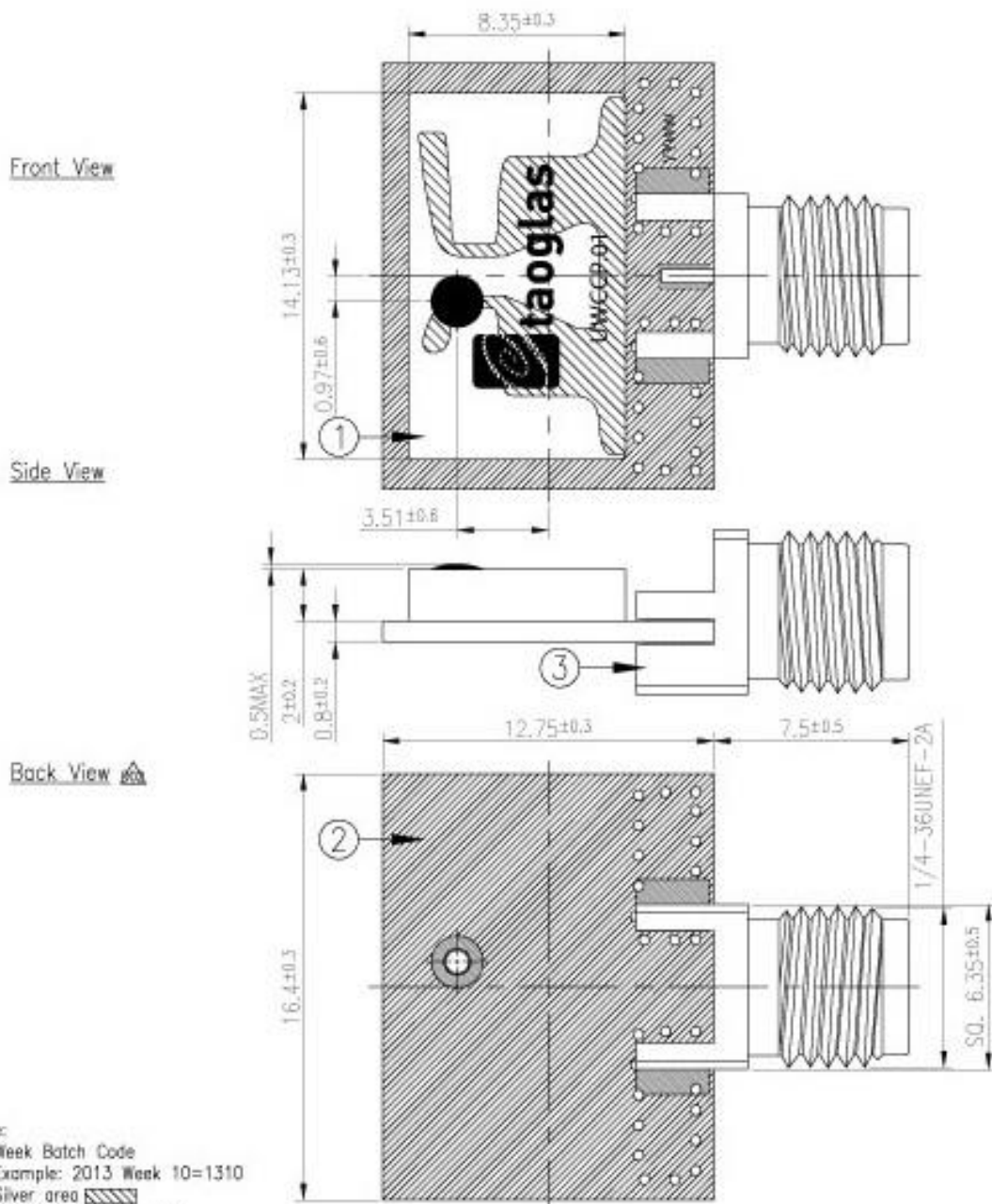
## 4. Mechanical Drawing (Unit - mm)



NOTES:  
 1. Silver Area. 

	Name	Material	Finish	QTY
1	Patch	Ceramic	Clear	1

## 4.1 Evaluation Board



**Note:**

1. Week Batch Code  
Example: 2013 Week 10=1310
2. Silver area 
3. Soldered area 
4. Soldermask area(Black) 
5. Logo & Text Ink Printing  
Patch: Black  
EVB PCB: White

Name	Material	Finish	QTY
1 UWCCP.01 Patch Antenna	Ceramic	Clear	1
2 UWCCPD.01 EVB PCB	Composite 0.8t	Black	1
3 SMA(F)ST	Brass	Au Plated	1

## 7. Application Note

### 7.1. Recommended Placement and Ground Plane Size

The recommended ground plane dimensions and antenna landing pattern are shown below. The antenna should be placed in the middle of the ground plane. The top plated footprint around the pin should be covered in solder mask so that the antenna pin is soldered to the PCB. No pin soldering is needed on the bottom side of the PCB.

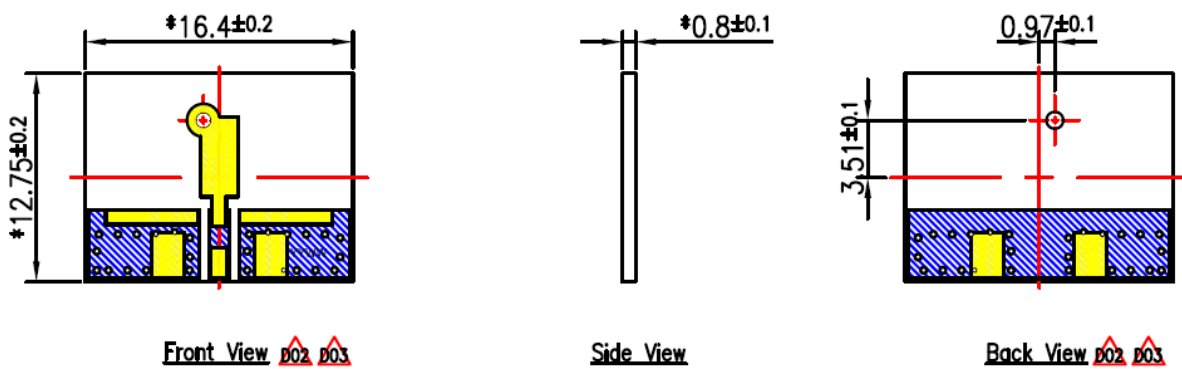


Figure 1 Evaluation Board

Copper Lay  Plated Lay 

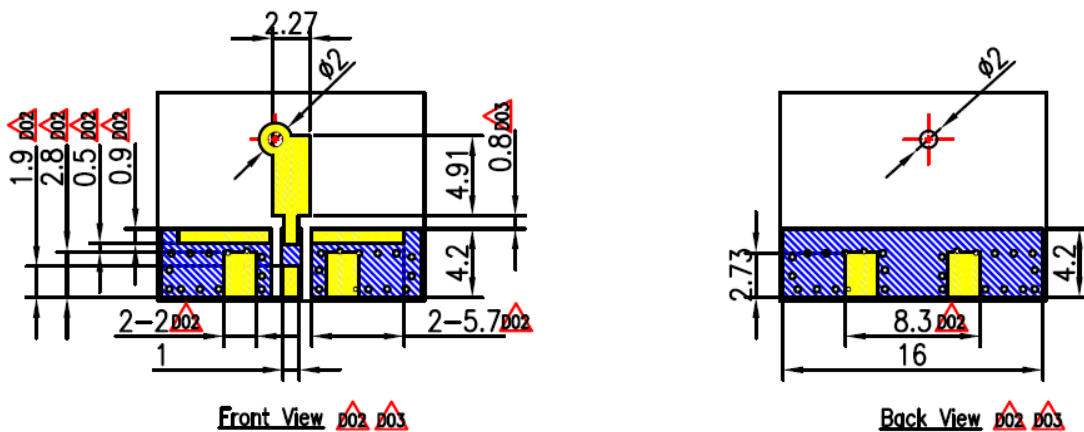


Figure 2 Detailed dimensions EVB front and back



## 7.2. Ground Plane Size Influence

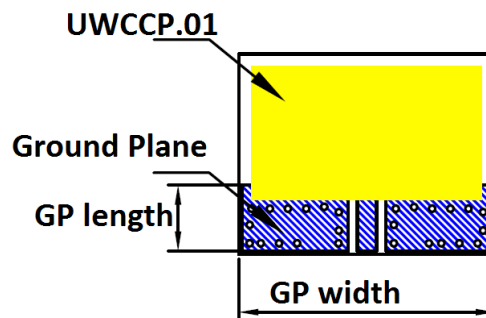
Influence of ground plane length and width is tested.

### Length

Graphs below show that there is only slight influence on S11 and on Efficiency when the ground plane length is increased. However the ground plane length has strong influence on the achieved axial ratio as seen in Figure 7. Those results show that length up to 10 mm maintains the antenna performance. Length of 15 mm is not recommended (square ground plane), lengths above 20 mm can be used but with precaution. Taoglas recommends making a small isolated RF ground for the UWCCP.01, in case large ground plane is needed for the device, connected with inductors to the main PCB ground.

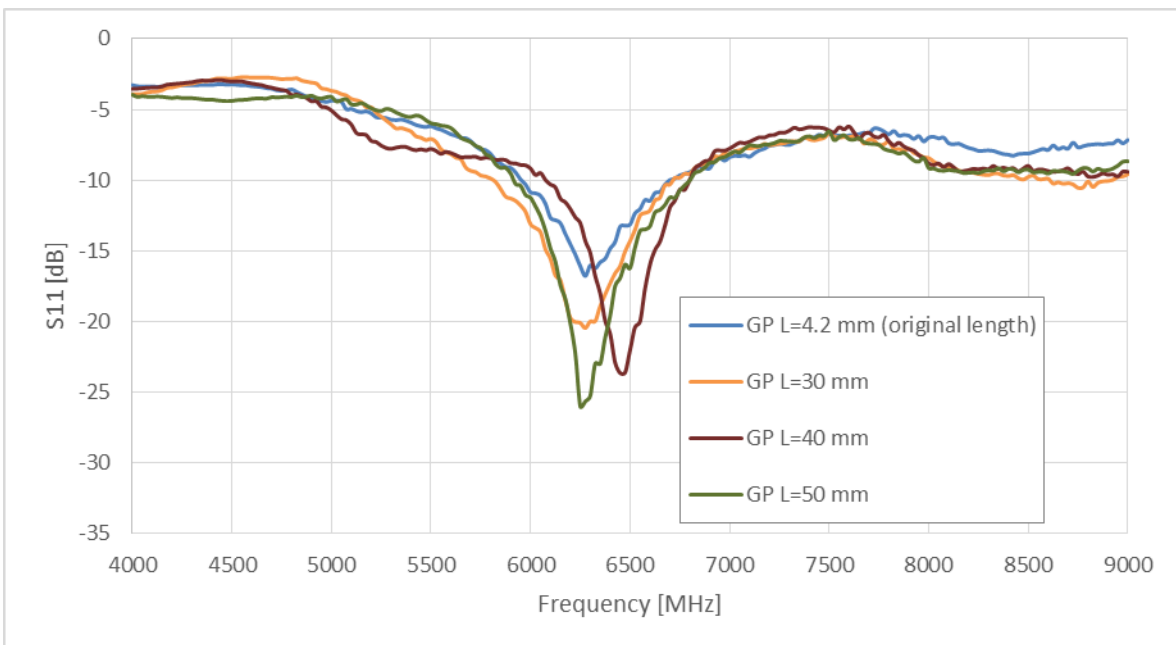
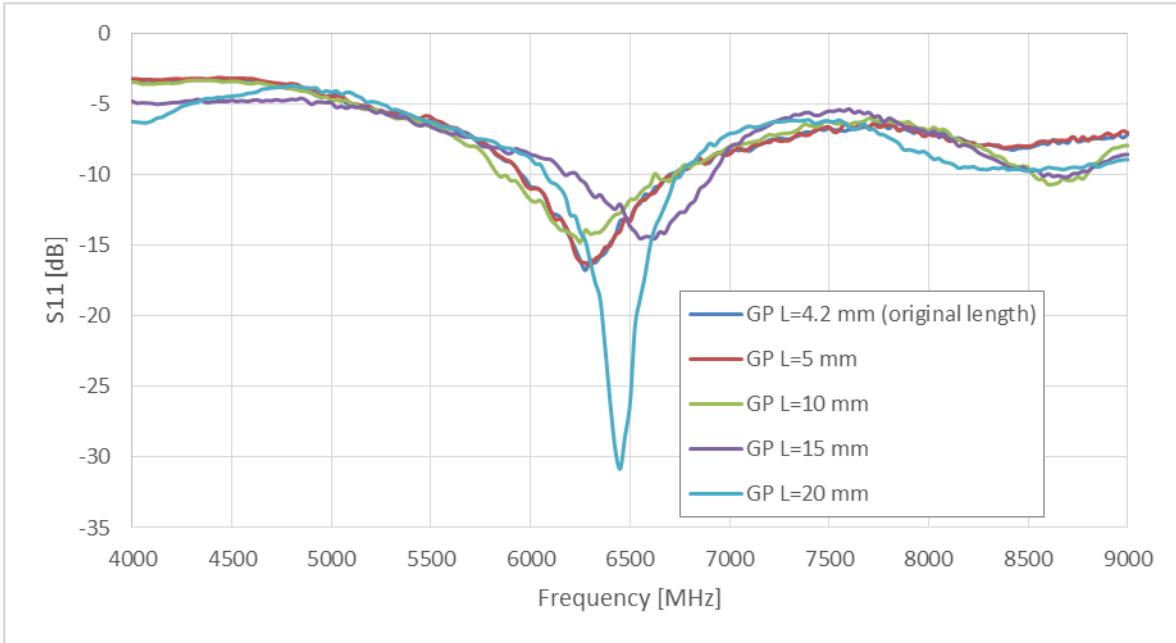
### Width

When the ground plane width is increased the antenna becomes detuned as evident on both S11 and efficiency. Axial Ratio, S11, and efficiency show that widths of 30 mm and 40 mm are not advisable.

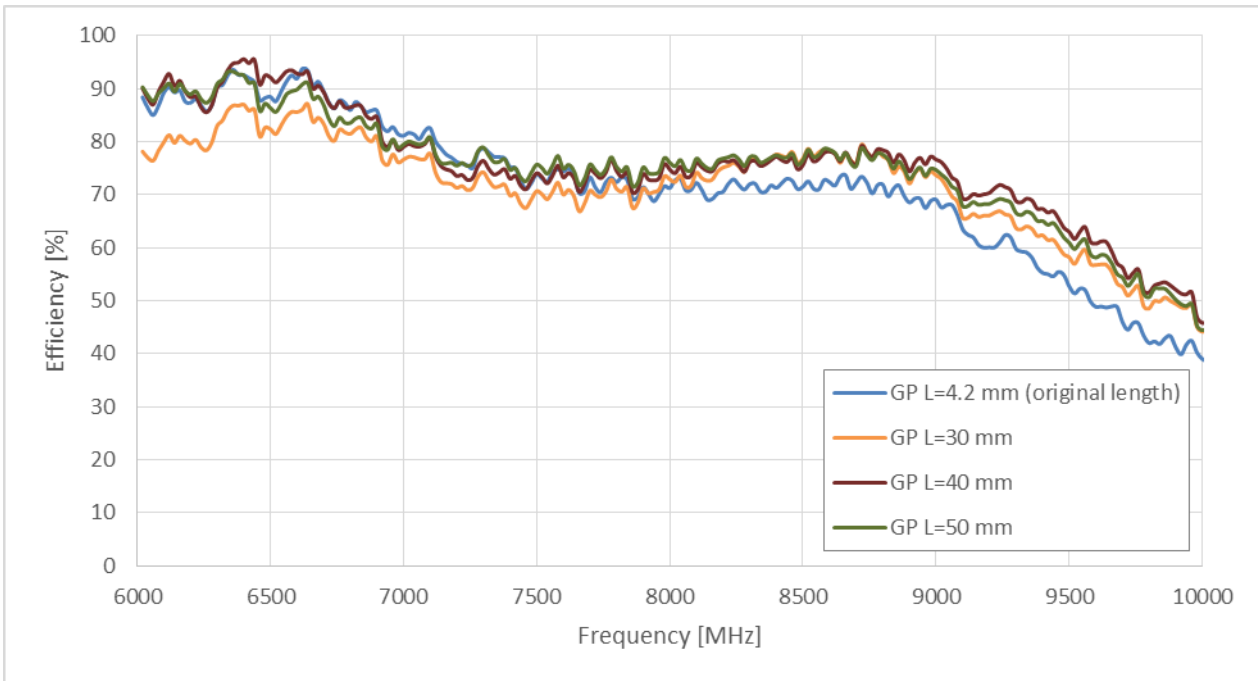
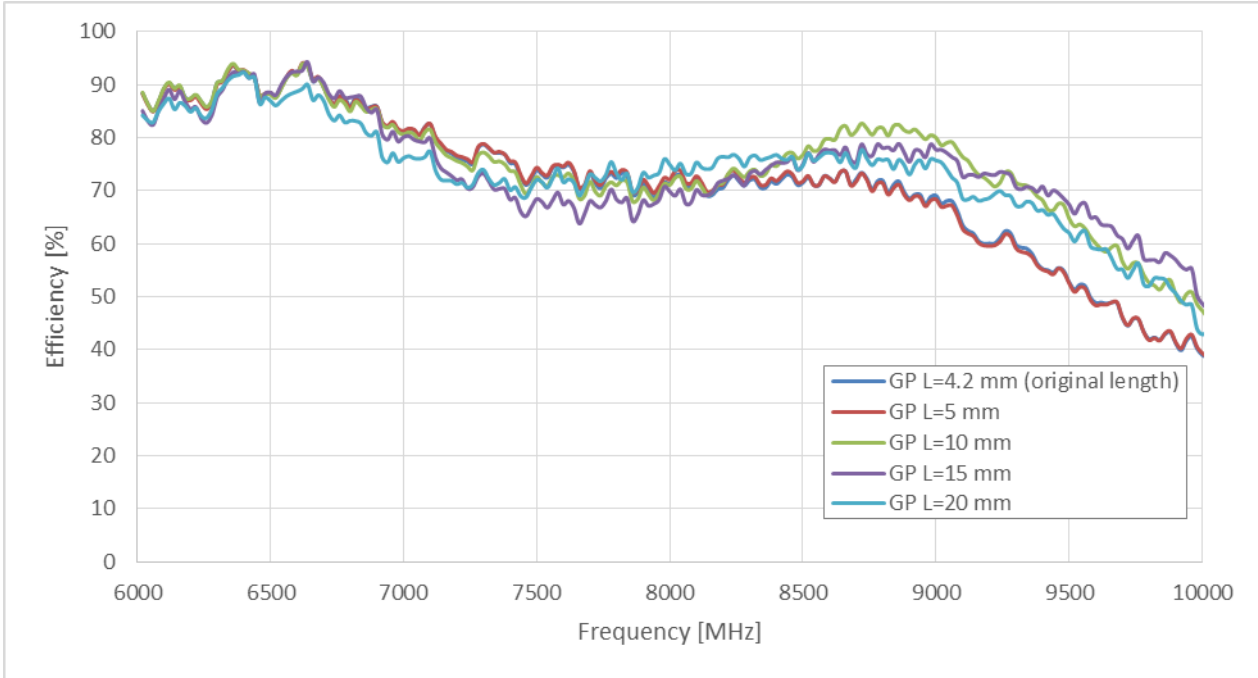


**Figure 3 Evaluation Board**

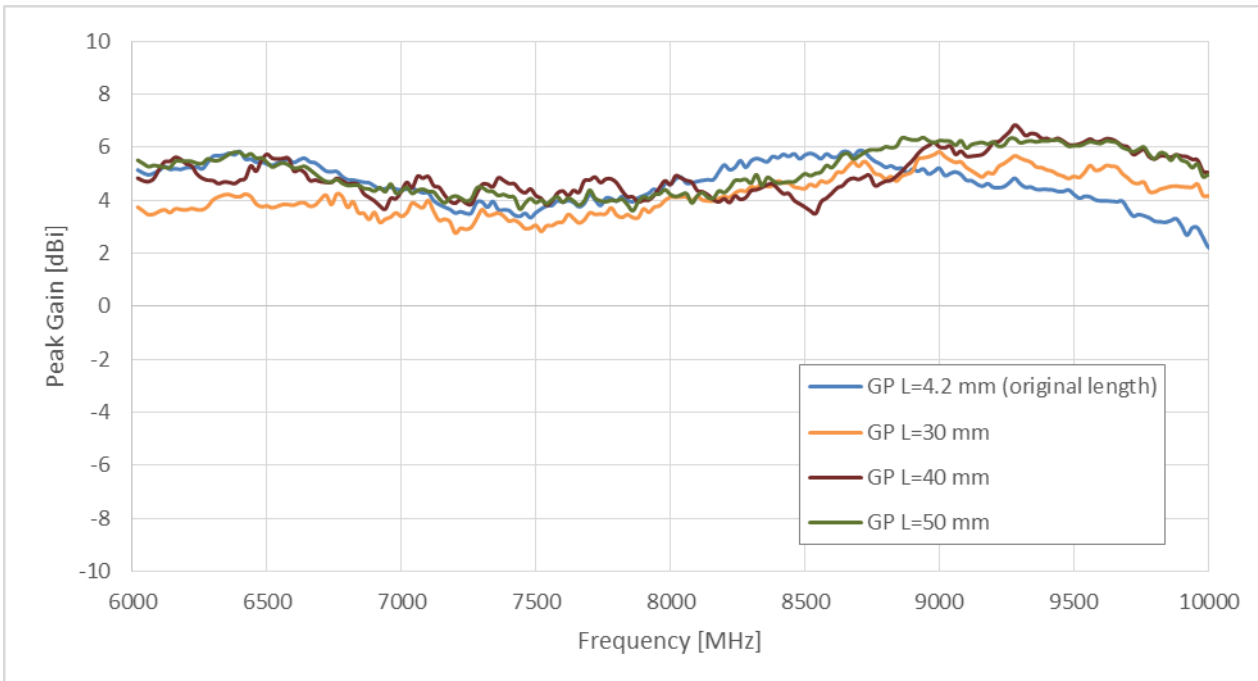
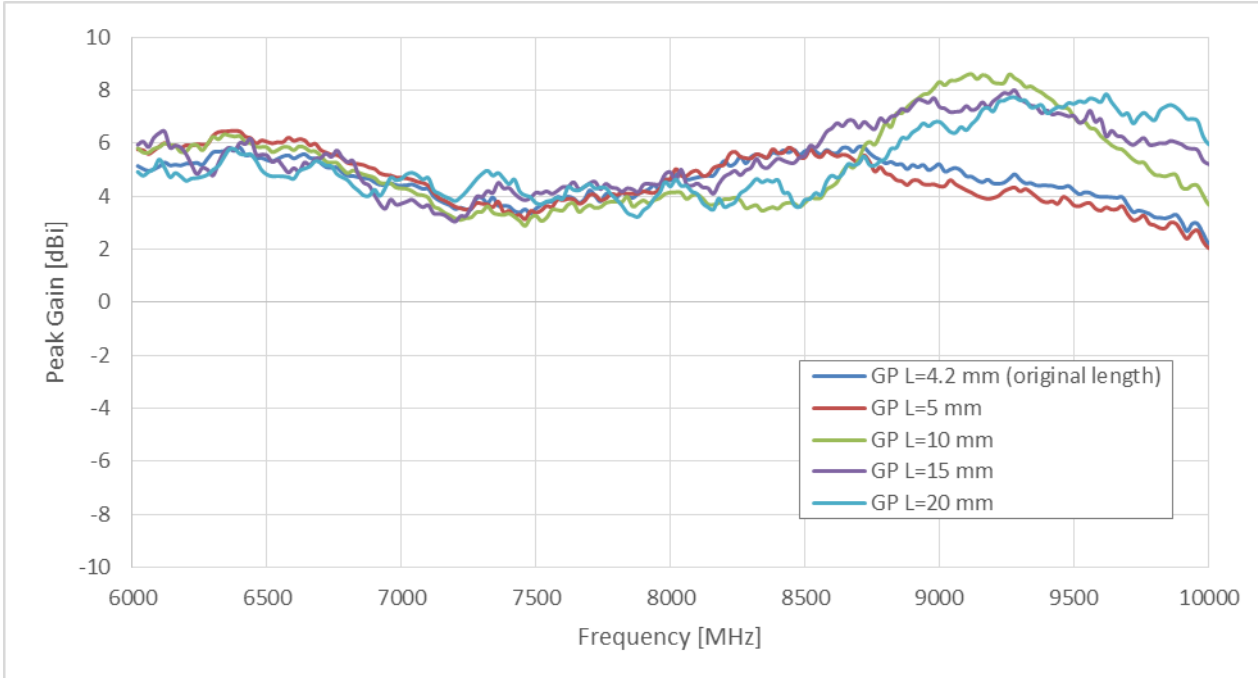
### 7.2.1. Ground Plane Length



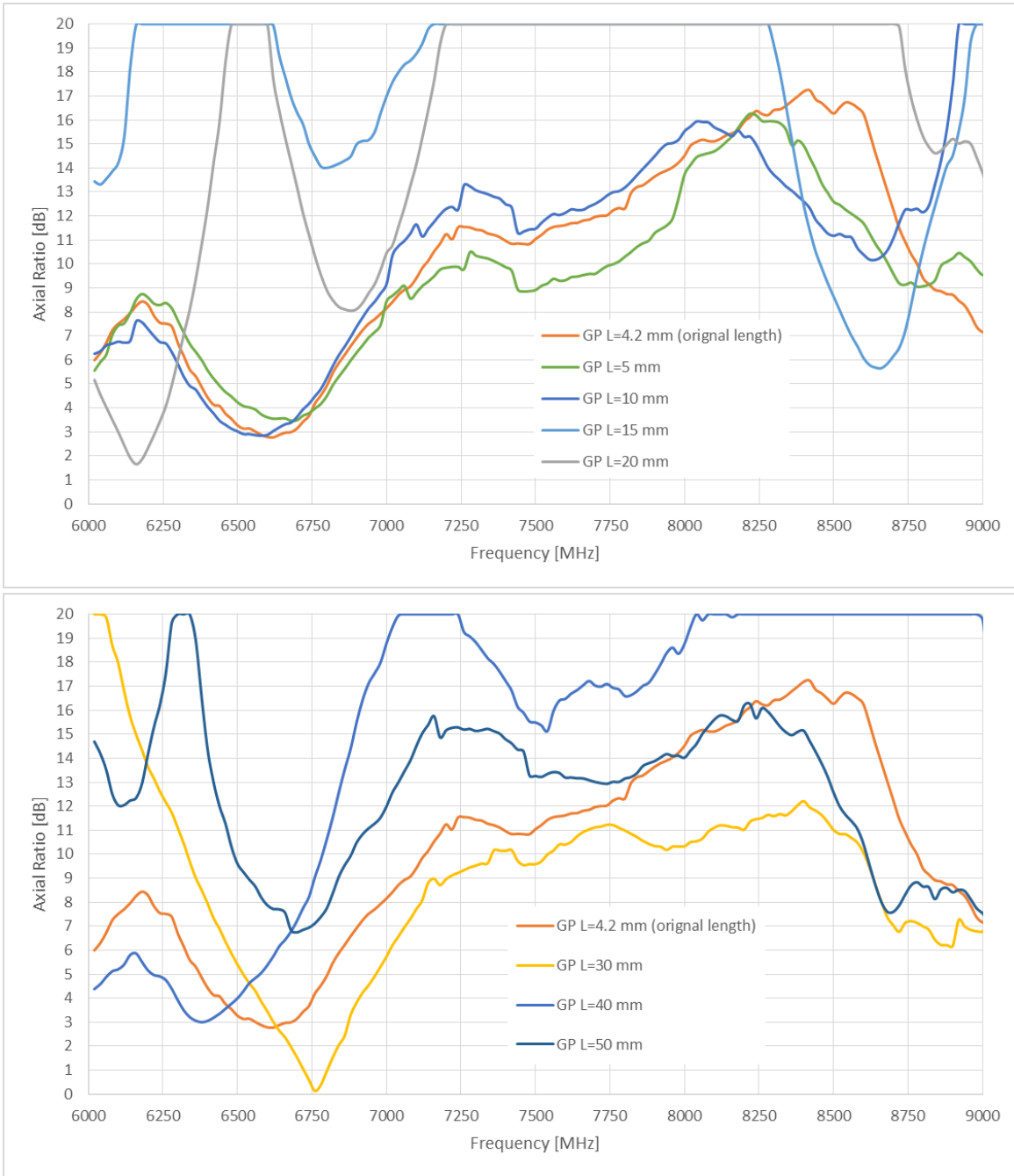
**Figure 4 Return loss for ground plane length variation**



**Figure 5 Efficiency for ground plane length variation**

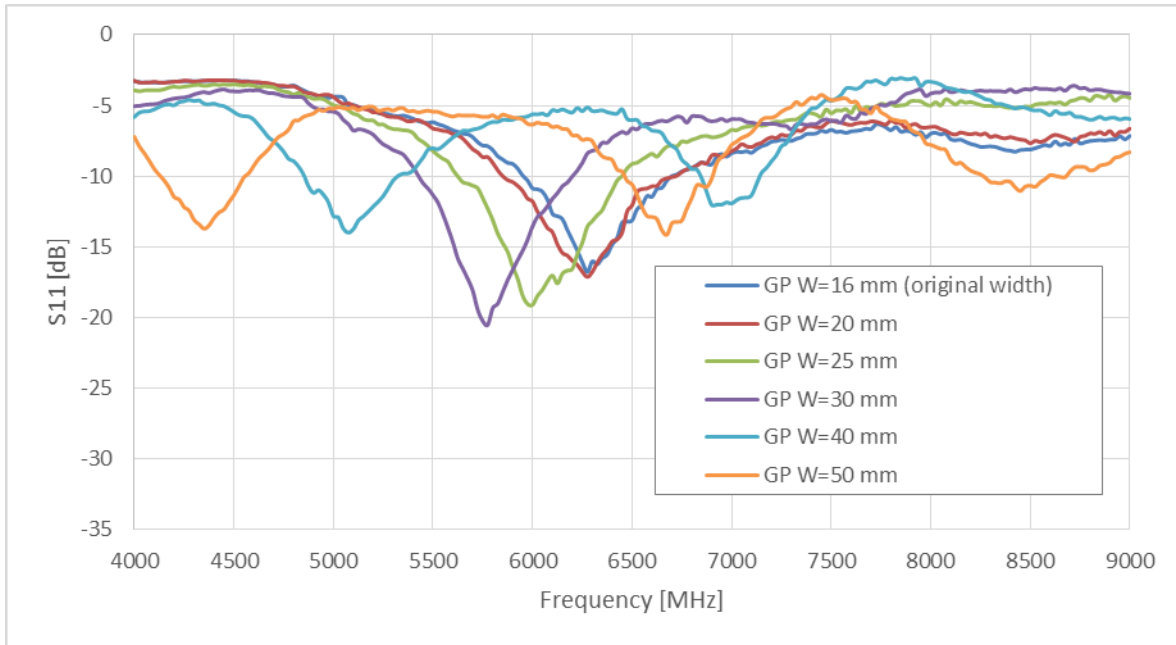


**Figure 6 Peak gain for ground plane length variation**

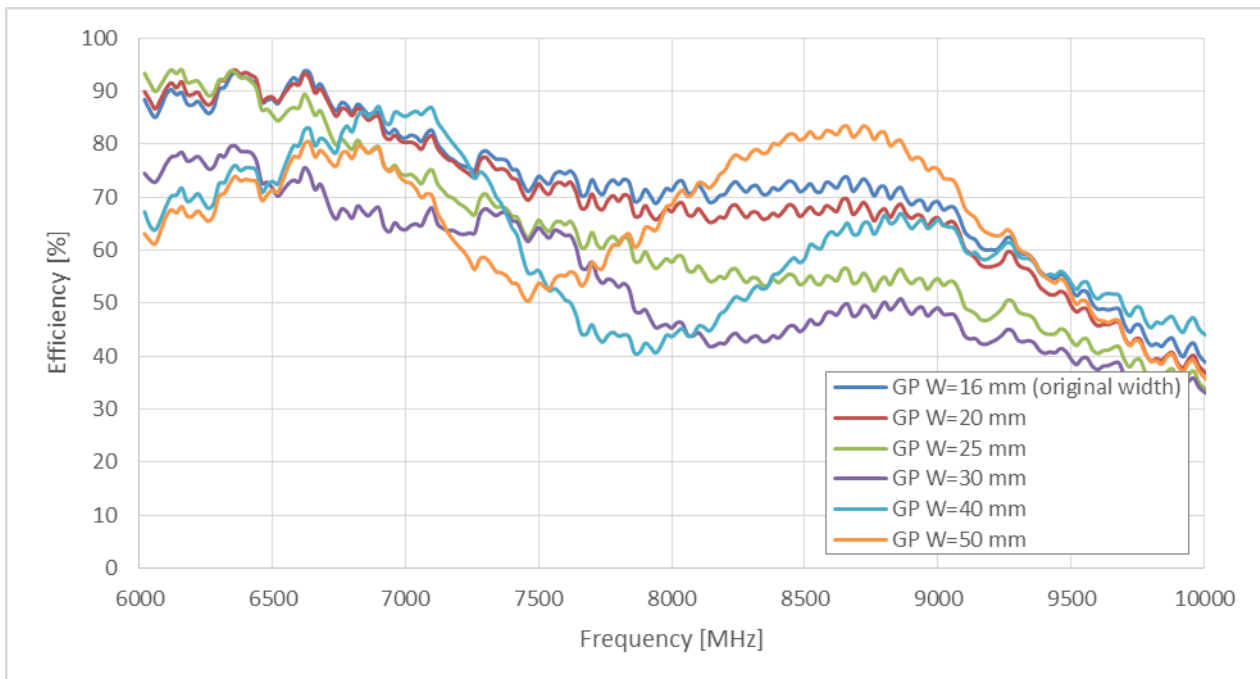


**Figure 7 Axial Ratio for ground plane length variation**

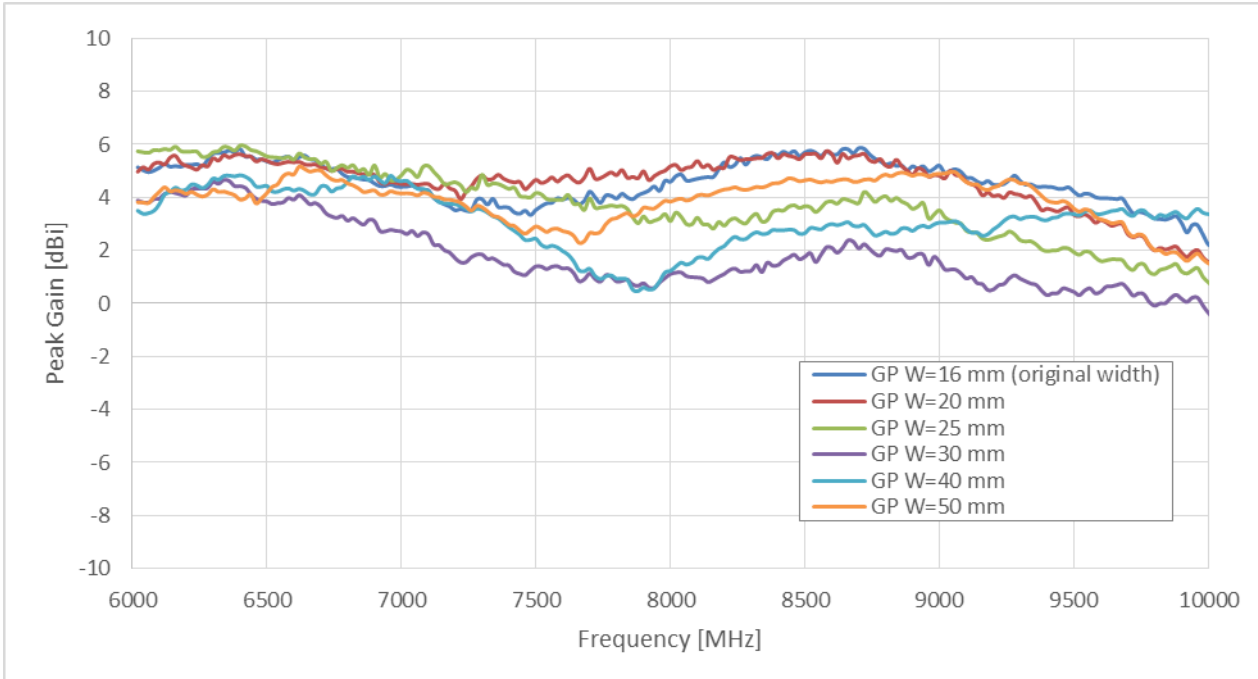
### 7.2.2. Ground plane width



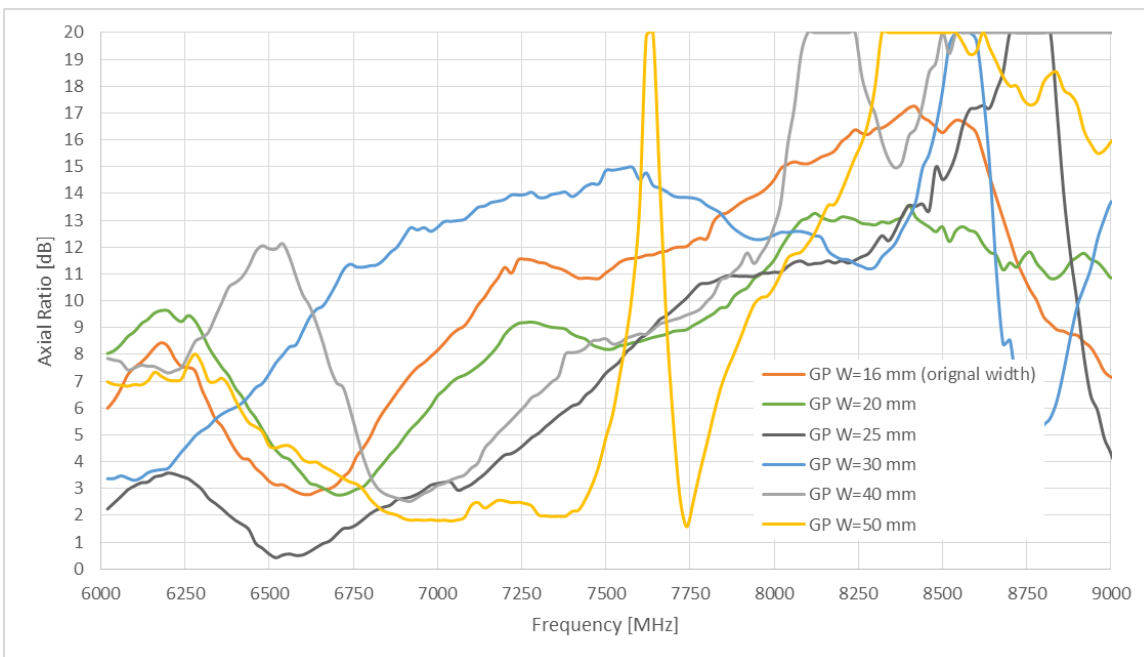
**Figure 8 Return loss for ground plane width variation**



**Figure 9 Efficiency for ground plane width variation**



**Figure 10 Peak gain for ground plane width variation**

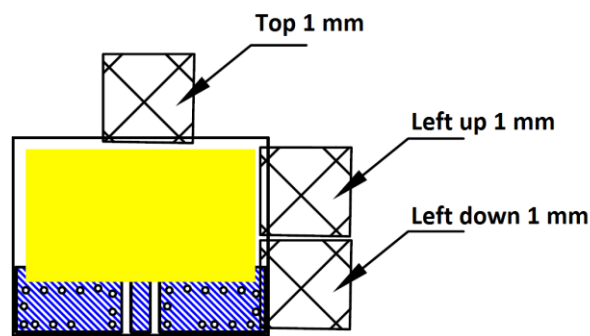


**Figure 11 Axial ratio for ground plane width variation**

### 7.3. Clearance Study

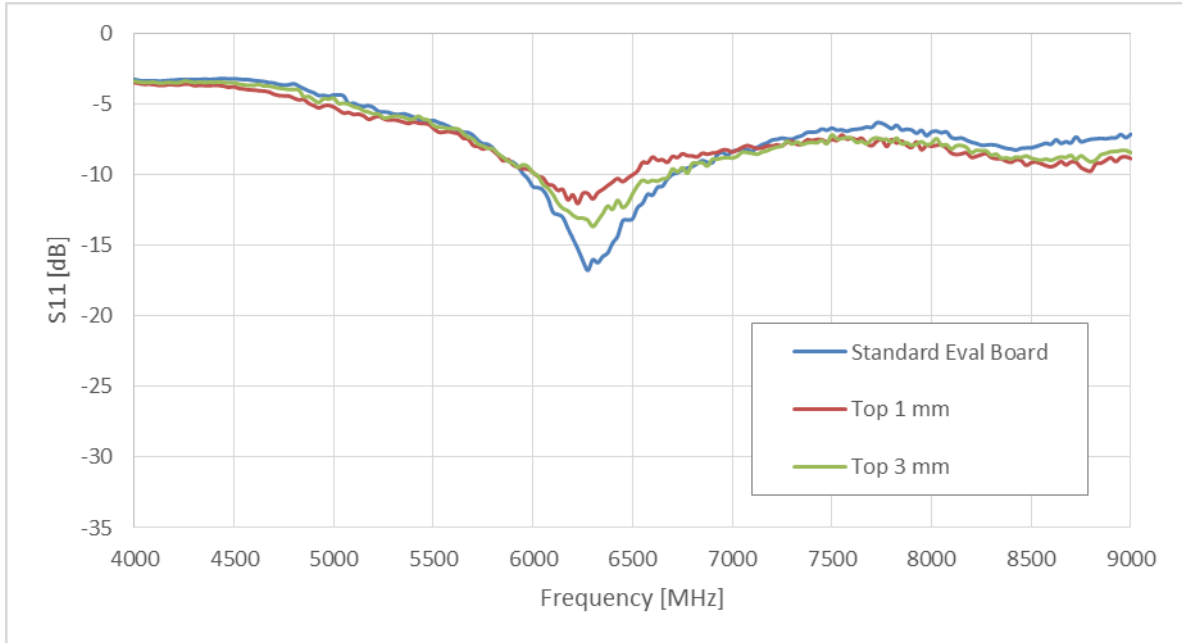
A metal clearance study is also performed. A 5\*5\*2mm metal component is placed on different locations around the UWCCP.01 antenna as shown in Figure 12. The component is either placed at 1mm or 3mm distance to the antenna.

The results show that components placed as close as 1 mm from the left, right, or top edge of the antenna will not significantly decrease performance. It is advised not to place components closer than 1 mm from the antenna.

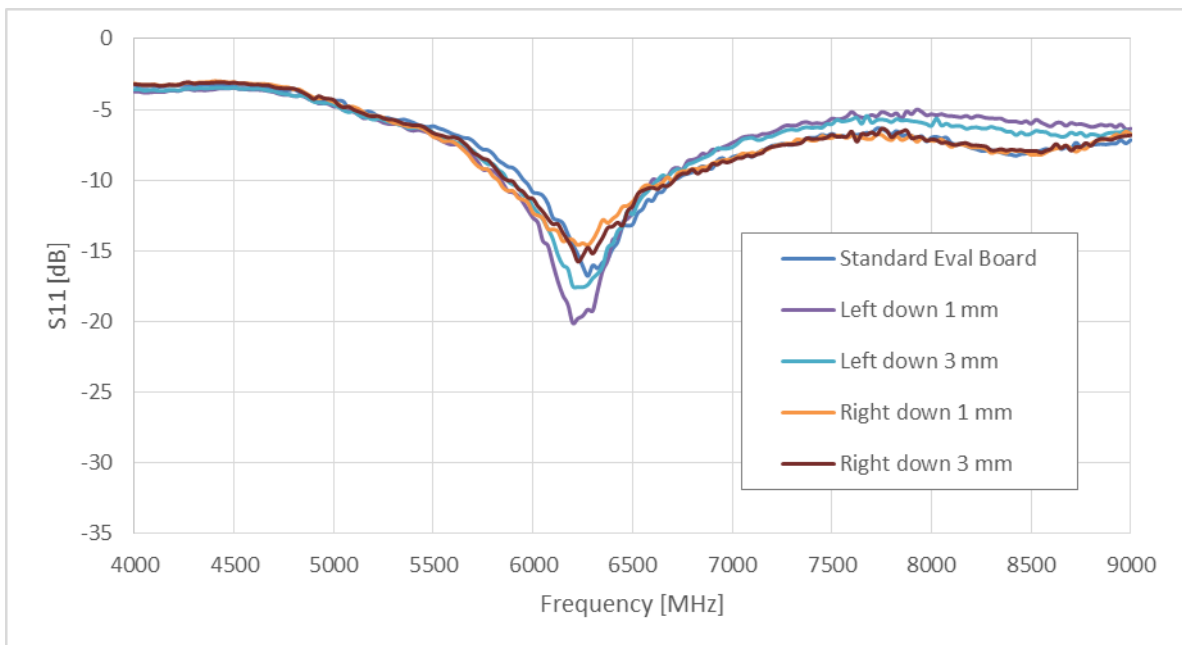


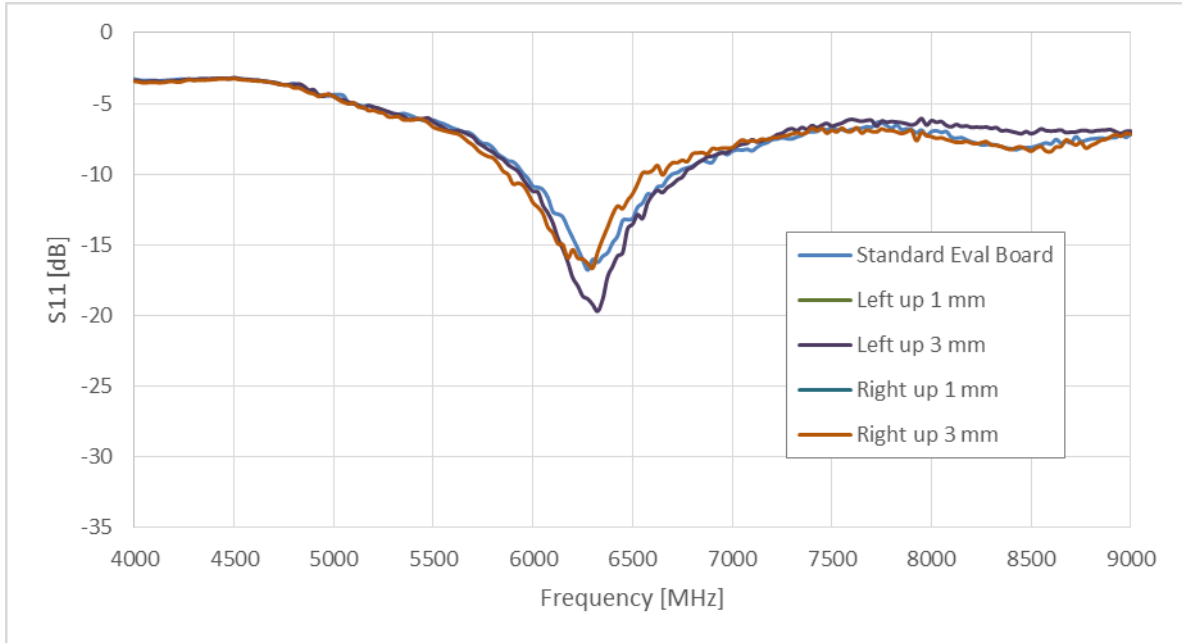
**Figure 12 Clearance study – metal component locations**



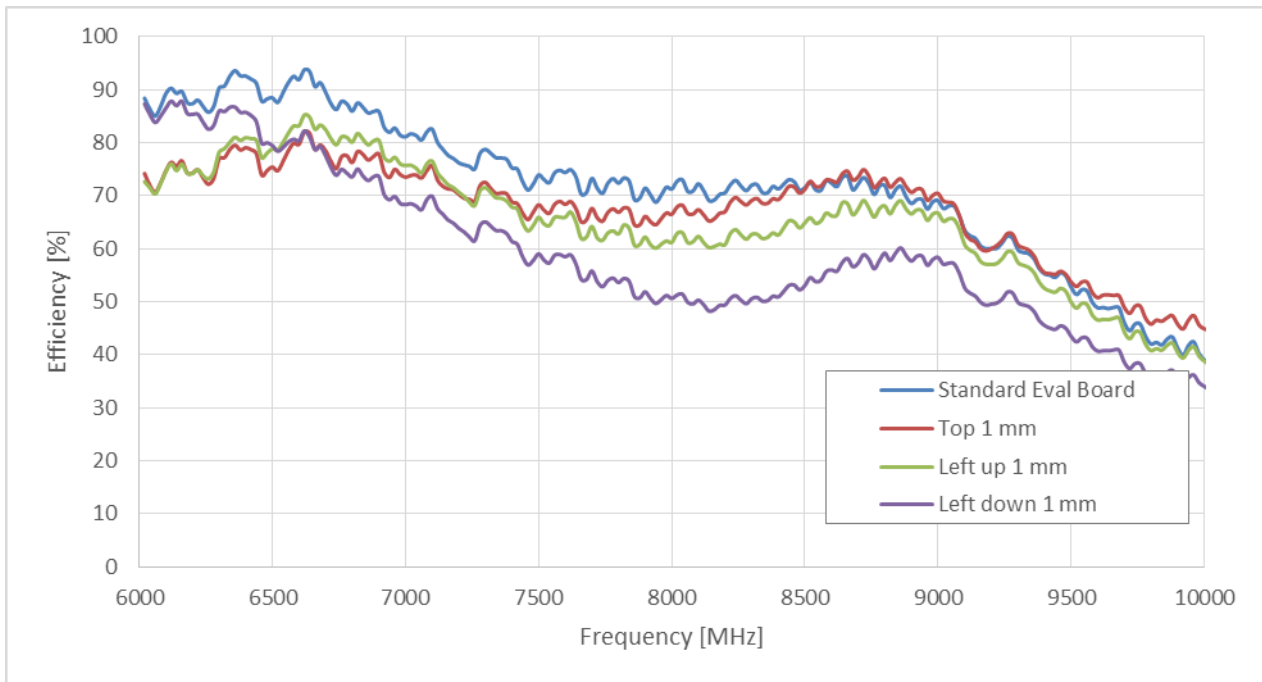


**Figure 13 Return loss for clearance study (top positions)**

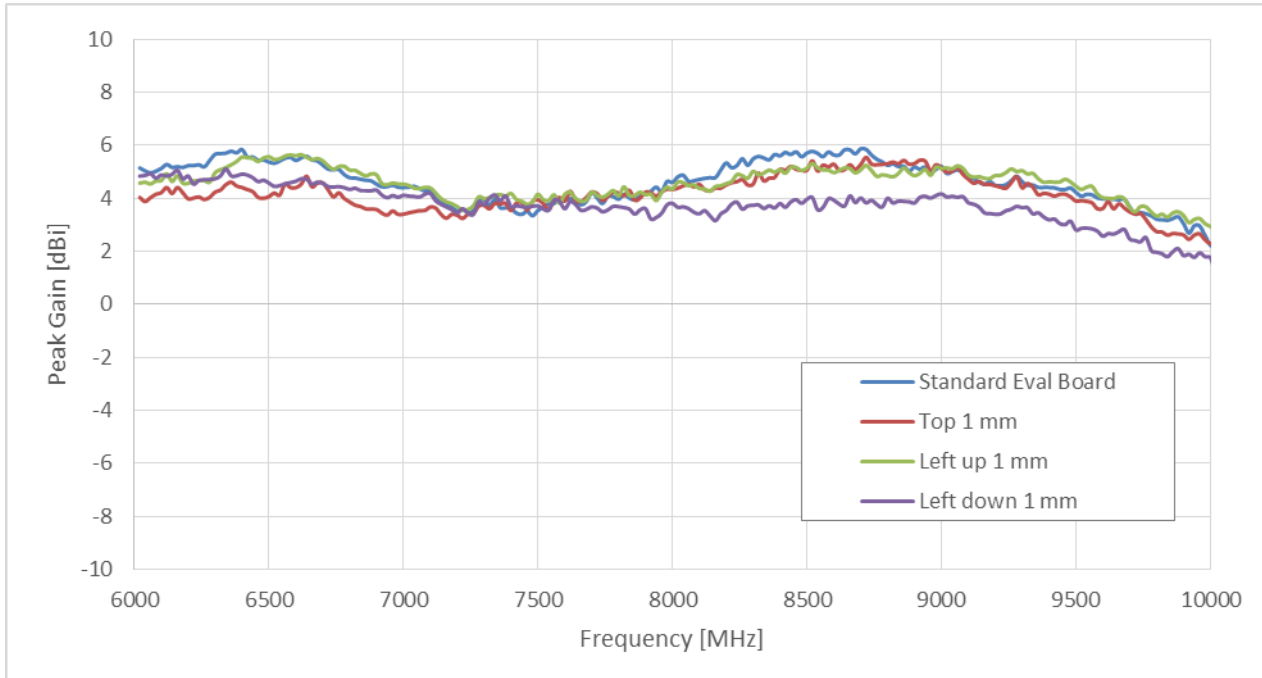




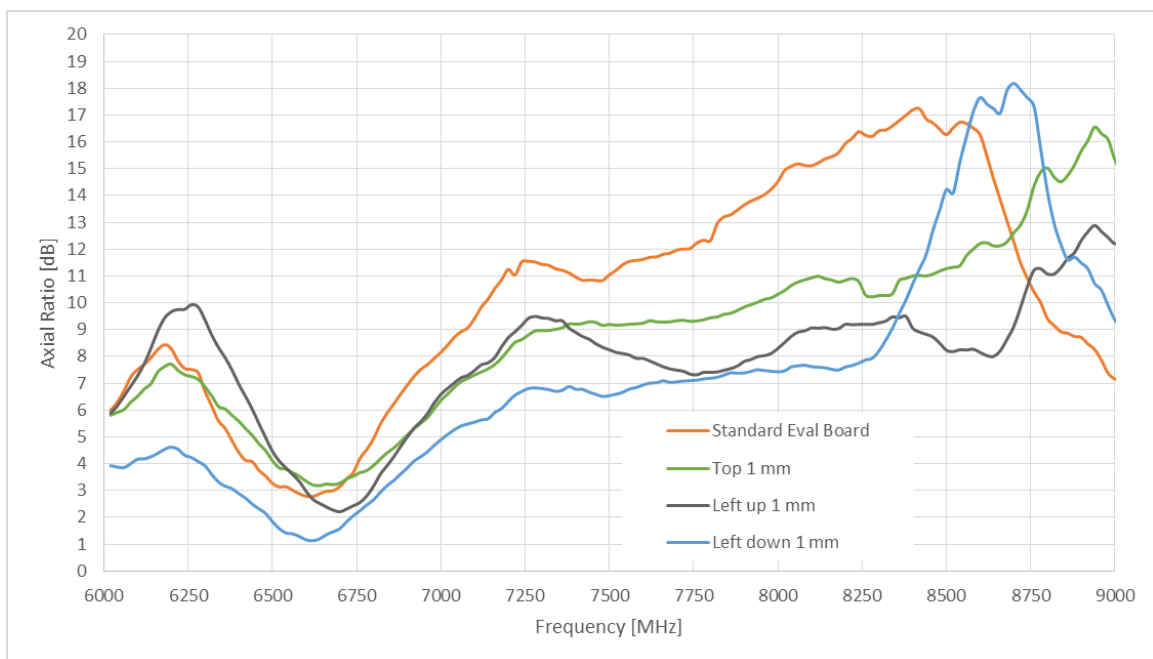
**Figure 14 Return loss for clearance study (side positions)**



**Figure 15 Efficiency for clearance study**



**Figure 16 Peak gain for clearance study**



**Figure 17 Axial ratio for clearance study**

Taoglas makes no warranties based on the accuracy or completeness of the contents of this document and reserves the right to make changes to specifications and product descriptions at any time without notice. Taoglas reserves all rights to this document and the information contained herein.

Reproduction, use or disclosure to third parties without express permission is strictly prohibited.

Copyright © Taoglas Ltd. 2017

## X-ON Electronics

Largest Supplier of Electrical and Electronic Components

*Click to view similar products for [Antennas](#) category:*

*Click to view products by [Taoglas](#) manufacturer:*

Other Similar products are found below :

[GAN30084EU](#) [930-033-R](#) [GW17.07.0250E](#) [1513563-1](#) [EXE902SM](#) [APAMPG-117](#) [MAF94383](#) [W3908B0100](#) [W6102B0100](#) [YE572113-30RSMM](#) [108-00014-50](#) [66089-2406](#) [SPDA17RP918](#) [A09-F8NF-M](#) [A09-F5NF-M](#) [RGFRA1903041A1T](#) [W3593B0100](#) [W3921B0100](#) [SIMNA-868](#) [SIMNA-915](#) [SIMNA-433](#) [W1044](#) [W1049B090](#) [A75-001](#) [WTL2449CQ1-FRSMM](#) [CPL9C](#) [EXB148BN](#) [0600-00060](#) [TRA9020S3PBN-001](#) [Y4503](#) [GD5W-28P-NF](#) [MA9-7N](#) [GD53-25](#) [GD5W-21P-NF](#) [C37](#) [MAF94051](#) [MA9-5N](#) [EXD420PL](#) [B1322NR](#) [QWFTB120](#) [MAF94271](#) [MAF94300](#) [GPSMB301](#) [FG4403](#) [AO-AGSM-OM54](#) [5200232](#) [MIKROE-2349](#) [WCM.01.0111](#) [MIKROE-2393](#) [MIKROE-2352](#)