

Tappex® MULTISERT®

BN 37885 - Press-in threaded Inserts without head, for thermoplastics

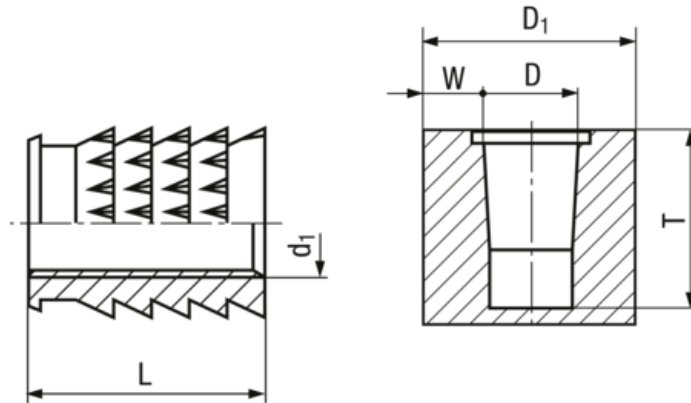

Manufacturer



Product description

- Patented external form
- Special plain location spigot
- Installation options: press-fitting, ultrasonic insertion, heat insertion

Additional information

Installation data hole location: The quoted dimensions represent standard values and may vary depending on the material of the molded part. It is advisable to run trials prior to series production.

Headform

Unheaded

Brand

Tappex®

Brandtype

MULTISERT®

Material

Brass

Surface

plain

Illustration assembly

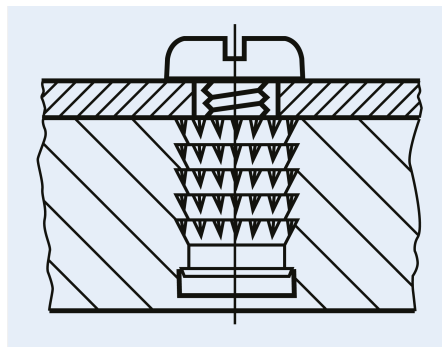

Article no	Code	Thread size d1	L +0/-0,25	D	W min	D1 min	T min
3795118	001-M2	M2	4,2	3-3,3	1,35	6	4,3
3795100	001-M2,5	M2,5	5,2	3,7-4	1,7	7,4	5,3
3794915	002-M2,5	M2,5	4,1	3,7-4	1,7	7,4	4,2
3794588	001-M3	M3	5,2	3,7-4	1,7	7,4	5,3

Article no	Code	Thread size d1	L +0/-0,25	D	W min	D1 min	T min
3794796	002-M3	M3	4,1	3,7-4	1,7	7,4	4,2
3794709	001-M4	M4	8,5	5,4-5,9	2,5	10,9	8,6
3794950	002-M4	M4	5,6	5,4-5,9	2,5	10,9	5,8
3794745	001-M5	M5	10,1	6-6,5	2,85	12,2	10,2
3795185	002-M5	M5	6,6	6-6,5	2,85	12,2	6,8
3795174	001-M6	M6	12,3	7,7-8,2	3,2	14,6	12,5
3794586	002-M6	M6	7,7	7,7-8,2	3,2	14,6	7,9
3795036	001-M8	M8	13,8	10,2-10,6	4,25	19,1	14
3794751	002-M8	M8	8,3	10,2-10,6	4,25	19,1	8,9
3795021	001-M10	M10	16,1	12,5-13	5,1	23,2	16,3

X-ON Electronics

Largest Supplier of Electrical and Electronic Components

Click to view similar products for [Tappex](#) manufacturer:

Other Similar products are found below :

[002M2](#) [002M4](#) [002M6](#) [002M8](#) [003M4](#) [004M3](#)