

Tappex® MULTISERT®

BN 37896 - Press-in threaded Inserts with large head, for thermoplastics

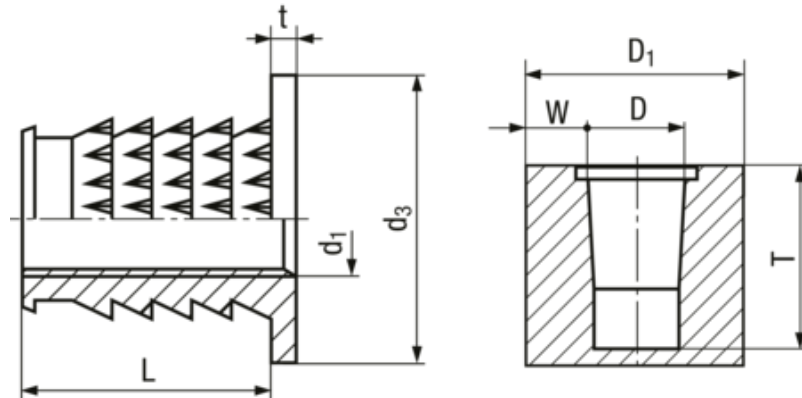

Manufacturer



Product description

- Patented external form
- Special plain location spigot
- Installation options: press-fitting, heat insertion

Additional information

Installation data hole location: The quoted dimensions represent standard values and may vary depending on the material of the molded part. It is advisable to run trials prior to series production.

Headform

Large

Brand

Tappex®

Brandtype

MULTISERT®

Material

Brass

Surface

plain

Illustration assembly

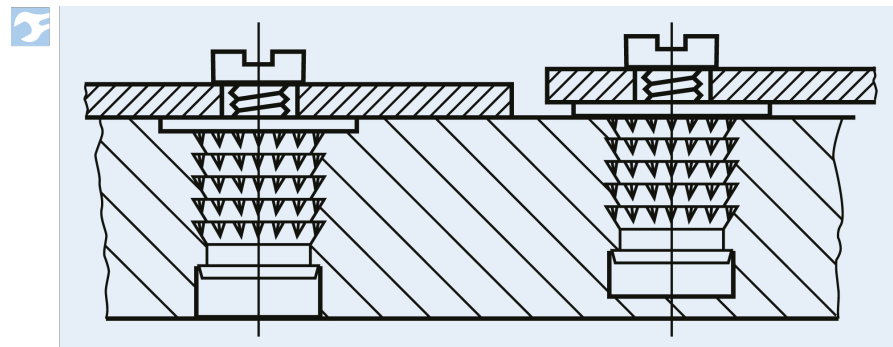

Article no	Code	Thread size d1	L +0/-0,25	d3 nom	D min	D1 min	t ±0,15	W min	T
3794712	003-M2,5	M2,5	5,2	7,1	3,7-4	7,4	0,75	1,7	5,3
3794697	004-M2,5	M2,5	4,1	7,1	3,7-4	7,4	0,75	1,7	4,2
3794979	003-M3	M3	5,2	7,1	3,7-4	7,4	0,75	1,7	5,3
3795177	004-M3	M3	4,1	7,1	3,7-4	7,4	0,75	1,7	4,2

Article no	Code	Thread size d1	L +0/-0,25	d3 nom	D min	D1 min	t ±0,15	W min	T
3795109	003-M4	M4	8,5	8,7	5,4-5,9	10,9	0,75	2,5	8,6
3794534	004-M4	M4	5,6	8,7	5,4-5,9	10,9	0,75	2,5	5,8
3794939	003-M5	M5	10,1	11,1	6-6,5	12,2	0,9	2,85	10,2
3795292	004-M5	M5	6,6	11,1	6-6,5	12,2	0,9	2,85	6,8
3794933	003-M6	M6	12,3	12,7	7,7-8,2	14,6	1	3,2	12,5
3794517	004-M6	M6	7,7	12,7	7,7-8,2	14,6	1	3,2	7,9
3795242	004-M8	M8	10,1	14,3	10,2-10,6	19,1	1,25	4,25	10,3

X-ON Electronics

Largest Supplier of Electrical and Electronic Components

Click to view similar products for [Tappex](#) manufacturer:

Other Similar products are found below :

[002M2](#) [002M4](#) [002M6](#) [002M8](#) [003M4](#) [004M3](#)