



Ferrites and accessories

Toroids (ring cores)
General information and overview

Date: May 2017

© EPCOS AG 2017. Reproduction, publication and dissemination of this publication, enclosures hereto and the information contained therein without EPCOS' prior express consent is prohibited.

EPCOS AG is a TDK Group Company.

Toroids (ring cores)

General information

Our product line includes a wide range of toroids with finely graded diameters ranging from 2.5 to 202 mm.

Other core heights can be supplied on request. All cores are available in the usual materials.

1 Applications

- Toroids are primarily used as EMC chokes for suppressing RF interference in the MHz region and in signal transformers.

Typical applications for toroids of NiZn ferrites are LAN chokes. One of the materials available for this purpose is K10; other materials on request.

The following high-permeability MnZn materials are available for interference suppression:

- R 2.5 through R 12.5 for telecommunications (N30, T38, T46)
 - R 13.3 through R 26 for power line chokes (N30, T65, T35, T37, T38)
 - >R 34 for chokes and filters in industrial use (T65)
- Toroids are also increasingly used for power applications. Here, the typical values for amplitude permeability and power loss, as summarized in the section on “*SIFERRIT Materials*” (page 36), are applicable to the special power materials.

2 Coating

Toroids are available in different coating versions, thus offering the appropriate solution for every application. The coating not only offers protection for the edges but also provides an insulation function.

For small ring cores, we have introduced a parylene coating which features a low coating thickness and high dielectric strength.

A coating of the core will cause μ_i to drop, depending on the core size. A similar effect might occur when the core is subjected to high winding forces, especially cores made of the high permeability materials, T38 and T46.

Toroids (ring cores)

General information

Coatings of ring cores

Version	Epoxy (blue)	Parylene (transparent)
Main application	Medium/big sizes ($\geq R 9.53$)	Small sizes ($< R 9.53$)
Layer thickness	< 0.4 mm	0.012 or 0.025 mm
Breakdown voltage (minimum values)	> 1.0 kV (for R 9.53; R 10) > 1.5 kV (for R 12.5 thru R 20) > 2.0 kV (for $> R 20$)	> 1 kV (standard value)
Mechanical quality	High firmness	Smooth surface
Maximum temperature (short-time)	approx. 180 °C	approx. 130 °C
Maximum temperature (long-time)	approx. 130 °C	approx. 130 °C
Advantage	Low influence on A_L value	Very low thickness
UL rating	UL 94 V-0	UL 94 V-0
UL file number	E194412/E257941	E194412
Ordering code	B64290L...	B64290P...

3 Dielectric strength test

The following test setup is used to test the dielectric strength of the insulating coating: A copper ring is pressed to the top edge of the ring. It touches the ferrite ring at the edges (see diagram).

The test duration is 2 seconds.

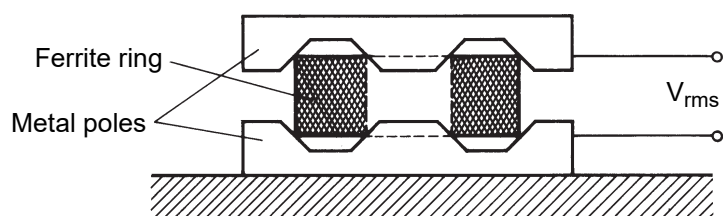

FUS0021-H

Toroids (ring cores)

General information

4 Chamfer

Large toroidal cores use thick wires that are partially subjected to high mechanical stress during winding. This can damage the wire insulation as well as the coating of the cores, thus reducing the breakdown voltage. To avoid this, EPCOS toroids have a chamfer. This prevents any insulation damage, and produces uniform coating thickness at the same time.

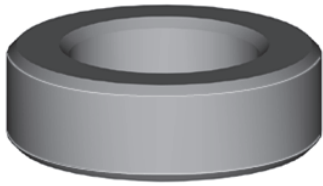

FUS0127-3

Core size	Design
Small	Edges rounded by tumbling
Medium	Chamfer on edges and/or radius on the surface
Medium/big	Chamfer on edges

5 Cutting

Middle size and large toroids are available with gap:

1.) Cut into 2 halves with typical cutting wheel thickness 1.2 mm.

2.) Cut gap in required thickness.

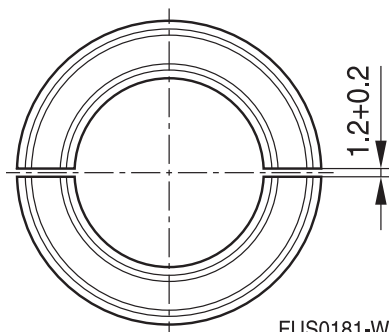

FUS0181-W

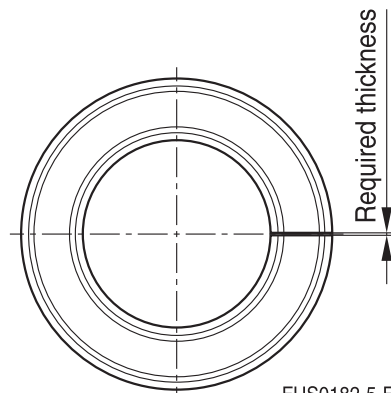

FUS0182-5-E

Three basic questions have to be answered during order:

- toroid cuts into 2 halves/only gap (picture 1 or 2)
- cutting before/after coating
 - before: air gap is coated
 - after: air gap is not coated, a measurement fixture can be placed into the air gap
- required thickness of the gap

Toroids (ring cores)

General information

6 Structure of the ordering code (part number)

Compilation of the ordering code

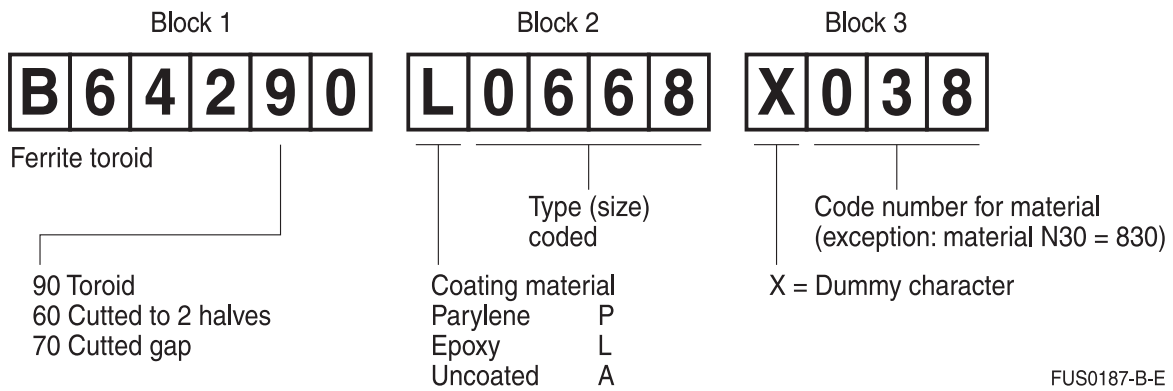

FUS0187-B-E

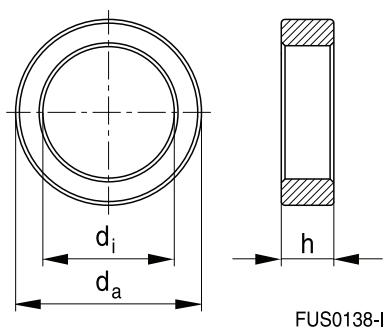
Toroids (ring cores)
Overview
B64290

Overview of available sizes

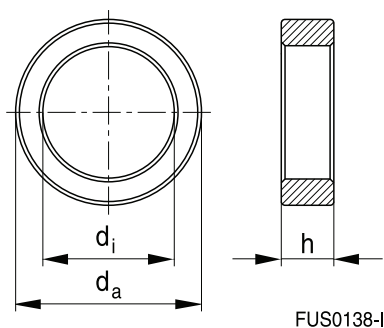
Type	Type code	Page
Toroid size ($d_a \times d_i \times h$)	(ordering code, block 2)	(Data book)
mm	inch	
R 2.50 × 1.50 × 1.00	R 0.098 × 0.059 × 0.039	P0035 624
R 2.50 × 1.50 × 1.30	R 0.098 × 0.059 × 0.051	P0072 624
R 2.54 × 1.27 × 1.27	R 0.100 × 0.050 × 0.050	P0734 625
R 3.05 × 1.27 × 1.27	R 0.120 × 0.050 × 0.050	P0683 625
R 3.05 × 1.27 × 2.54	R 0.120 × 0.050 × 0.100	P0739 626
R 3.05 × 1.78 × 2.03	R 0.120 × 0.070 × 0.080	P0733 626
R 3.43 × 1.78 × 1.78	R 0.135 × 0.070 × 0.070	P0731 627
R 3.43 × 1.78 × 2.03	R 0.135 × 0.070 × 0.080	P0745 627
R 3.94 × 1.78 × 1.78	R 0.155 × 0.070 × 0.070	P0732 628
R 3.94 × 2.24 × 1.30	R 0.155 × 0.088 × 0.051	P0061 628
R 3.94 × 2.24 × 2.30	R 0.155 × 0.088 × 0.090	P0723 629
R 4.00 × 2.40 × 1.60	R 0.157 × 0.094 × 0.063	P0036 629
R 4.00 × 2.40 × 1.80	R 0.157 × 0.094 × 0.071	P0692 630
R 5.84 × 3.05 × 1.52	R 0.230 × 0.120 × 0.060	P0056 630
R 5.84 × 3.05 × 3.00	R 0.230 × 0.120 × 0.118	P0687 631
R 6.30 × 3.80 × 2.50	R 0.248 × 0.150 × 0.098	P0037 631
R 8.00 × 4.00 × 4.00	R 0.315 × 0.158 × 0.158	P0751 632
R 9.53 × 4.75 × 3.17	R 0.375 × 0.187 × 0.125	L0062 632
R 10.0 × 6.00 × 4.00	R 0.394 × 0.236 × 0.157	L0038 633
R 10.0 × 6.00 × 7.00	R 0.394 × 0.236 × 0.318	L0783 633
R 12.5 × 7.50 × 5.00	R 0.492 × 0.295 × 0.197	L0044 634
R 12.7 × 7.90 × 6.35	R 0.500 × 0.311 × 0.250	L0742 634
R 13.3 × 8.30 × 5.00	R 0.524 × 0.327 × 0.197	L0644 635
R 14.0 × 9.00 × 5.00	R 0.551 × 0.354 × 0.197	L0658 635
R 15.0 × 10.4 × 5.30	R 0.591 × 0.409 × 0.209	L0623 636
R 15.8 × 8.90 × 4.70	R 0.622 × 0.350 × 0.185	L0743 636
R 16.0 × 9.60 × 6.30	R 0.630 × 0.378 × 0.248	L0045 637

Toroids (ring cores)
Overview
B64290

Overview of available sizes (continued)

Type	Type code	Page
Toroid size ($d_a \times d_i \times h$)	(ordering code,	(Data
mm	block 2)	book)
inch		
R 17.0 × 10.7 × 6.80	R 0.669 × 0.421 × 0.268	L0652 638
R 18.4 × 5.90 × 5.90	R 0.724 × 0.232 × 0.232	L0697 638
R 20.0 × 10.0 × 7.00	R 0.787 × 0.394 × 0.276	L0632 639
R 20.0 × 10.0 × 10.0	R 0.787 × 0.394 × 0.394	L0631 639
R 20.0 × 10.0 × 15.0	R 0.787 × 0.394 × 0.591	L0710 640
R 22.1 × 13.7 × 6.35	R 0.870 × 0.539 × 0.250	L0638 640
R 22.1 × 13.7 × 7.90	R 0.870 × 0.539 × 0.311	L0719 641
R 22.1 × 13.7 × 12.5	R 0.870 × 0.539 × 0.492	L0651 641
R 22.6 × 14.7 × 9.20	R 0.890 × 0.579 × 0.362	L0626 642
R 25.3 × 14.8 × 10.0	R 0.996 × 0.583 × 0.394	L0618 642
R 25.3 × 14.8 × 15.0	R 0.996 × 0.583 × 0.590	L0615 643
R 25.3 × 14.8 × 20.0	R 0.996 × 0.583 × 0.787	L0616 643
R 29.5 × 19.0 × 14.9	R 1.142 × 0.748 × 0.587	L0647 644
R 30.5 × 20.0 × 12.5	R 1.201 × 0.787 × 0.492	L0657 644
R 34.0 × 20.5 × 10.0	R 1.339 × 0.807 × 0.394	L0058 645
R 34.0 × 20.5 × 12.5	R 1.339 × 0.807 × 0.492	L0048 645
R 36.0 × 23.0 × 15.0	R 1.417 × 0.906 × 0.591	L0674 646
R 38.1 × 19.05 × 12.7	R 1.500 × 0.750 × 0.500	L0668 646
R 40.0 × 24.0 × 16.0	R 1.575 × 0.945 × 0.630	L0659 647
R 41.8 × 26.2 × 12.5	R 1.646 × 1.031 × 0.492	L0022 647
R 50.0 × 30.0 × 20.0	R 1.969 × 1.181 × 0.787	L0082 648
R 58.3 × 32.0 × 18.0	R 2.295 × 1.260 × 0.709	L0043 649
R 58.3 × 40.8 × 17.6	R 2.295 × 1.606 × 0.693	L0040 650
R 58.3 × 40.8 × 20.2	R 2.295 × 1.606 × 0.795	L0042 651
R 63.0 × 38.0 × 25.0	R 2.480 × 1.496 × 0.984	L0699 652
R 68.0 × 48.0 × 13.0	R 2.677 × 1.890 × 0.512	L0696 653
R 87.0 × 54.3 × 13.5	R 3.425 × 2.138 × 0.531	L0730 654
R 102 × 65.8 × 15.0	R 4.016 × 2.591 × 0.591	L0084 655

Toroids (ring cores)

Overview

Type	Type code	Page
Toroid size ($d_a \times d_i \times h$)	(ordering code, block 2)	(Data book)
mm	inch	
R 140 × 103 × 25.0	R 5.512 × 4.055 × 0.984	A0705
R 202 × 153 × 25.0	R 7.953 × 6.024 × 0.984	A0711

Ferrites and accessories

Cautions and warnings

Mechanical stress and mounting

Ferrite cores have to meet mechanical requirements during assembling and for a growing number of applications. Since ferrites are ceramic materials one has to be aware of the special behavior under mechanical load.

As valid for any ceramic material, ferrite cores are brittle and sensitive to any shock, fast temperature changing or tensile load. Especially high cooling rates under ultrasonic cleaning and high static or cyclic loads can cause cracks or failure of the ferrite cores.

For detailed information see data book, chapter “*General - Definitions, 8.1*”.

Effects of core combination on A_L value

Stresses in the core affect not only the mechanical but also the magnetic properties. It is apparent that the initial permeability is dependent on the stress state of the core. The higher the stresses are in the core, the lower is the value for the initial permeability. Thus the embedding medium should have the greatest possible elasticity.

For detailed information see data book, chapter “*General - Definitions, 8.1*”.

Heating up

Ferrites can run hot during operation at higher flux densities and higher frequencies.

NiZn-materials

The magnetic properties of NiZn-materials can change irreversible in high magnetic fields.

Ferrite Accessories

EPCOS ferrite accessories have been designed and evaluated only in combination with EPCOS ferrite cores. EPCOS explicitly points out that EPCOS ferrite accessories or EPCOS ferrite cores may not be compatible with those of other manufacturers. Any such combination requires prior testing by the customer and will be at the customer’s own risk.

EPCOS assumes no warranty or reliability for the combination of EPCOS ferrite accessories with cores and other accessories from any other manufacturer.

Processing remarks

The start of the winding process should be soft. Else the flanges may be destroyed.

- Too strong winding forces may blast the flanges or squeeze the tube that the cores can not be mounted any more.
- Too long soldering time at high temperature (>300 °C) may effect coplanarity or pin arrangement.
- Not following the processing notes for soldering of the J-leg terminals may cause solderability problems at the transformer because of pollution with Sn oxyde of the tin bath or burned insulation of the wire. For detailed information see chapter “*Processing notes*”, section 2.2.
- The dimensions of the hole arrangement have fixed values and should be understood as a recommendation for drilling the printed circuit board. For dimensioning the pins, the group of holes can only be seen under certain conditions, as they fit into the given hole arrangement. To avoid problems when mounting the transformer, the manufacturing tolerances for positioning the customers’ drilling process must be considered by increasing the hole diameter.

Display of ordering codes for EPCOS products

The ordering code for one and the same product can be represented differently in data sheets, data books, other publications and the website of EPCOS, or in order-related documents such as shipping notes, order confirmations and product labels. **The varying representations of the ordering codes are due to different processes employed and do not affect the specifications of the respective products.** Detailed information can be found on the Internet under www.epcos.com/orderingcodes.

Ferrites and accessories
Symbols and terms

Symbol	Meaning	Unit
A	Cross section of coil	mm ²
A _e	Effective magnetic cross section	mm ²
A _L	Inductance factor; $A_L = L/N^2$	nH
A _{L1}	Minimum inductance at defined high saturation ($\hat{=} \mu_a$)	nH
A _{min}	Minimum core cross section	mm ²
A _N	Winding cross section	mm ²
A _R	Resistance factor; $A_R = R_{Cu}/N^2$	$\mu\Omega = 10^{-6} \Omega$
B	RMS value of magnetic flux density	Vs/m ² , mT
ΔB	Flux density deviation	Vs/m ² , mT
\hat{B}	Peak value of magnetic flux density	Vs/m ² , mT
$\Delta \hat{B}$	Peak value of flux density deviation	Vs/m ² , mT
B _{DC}	DC magnetic flux density	Vs/m ² , mT
B _R	Remanent flux density	Vs/m ² , mT
B _S	Saturation magnetization	Vs/m ² , mT
C ₀	Winding capacitance	F = As/V
CDF	Core distortion factor	mm ^{-4.5}
DF	Relative disaccommodation coefficient $DF = d/\mu_i$	
d	Disaccommodation coefficient	
E _a	Activation energy	J
f	Frequency	s ⁻¹ , Hz
f _{cutoff}	Cut-off frequency	s ⁻¹ , Hz
f _{max}	Upper frequency limit	s ⁻¹ , Hz
f _{min}	Lower frequency limit	s ⁻¹ , Hz
f _r	Resonance frequency	s ⁻¹ , Hz
f _{Cu}	Copper filling factor	
g	Air gap	mm
H	RMS value of magnetic field strength	A/m
\hat{H}	Peak value of magnetic field strength	A/m
H _{DC}	DC field strength	A/m
H _c	Coercive field strength	A/m
h	Hysteresis coefficient of material	10 ⁻⁶ cm/A
h/ μ_i^2	Relative hysteresis coefficient	10 ⁻⁶ cm/A
I	RMS value of current	A
I _{DC}	Direct current	A
\hat{I}	Peak value of current	A
J	Polarization	Vs/m ²
k	Boltzmann constant	J/K
k ₃	Third harmonic distortion	
k _{3c}	Circuit third harmonic distortion	
L	Inductance	H = Vs/A

Ferrites and accessories
Symbols and terms

Symbol	Meaning	Unit
$\Delta L/L$	Relative inductance change	H
L_0	Inductance of coil without core	H
L_H	Main inductance	H
L_p	Parallel inductance	H
L_{rev}	Reversible inductance	H
L_s	Series inductance	H
l_e	Effective magnetic path length	mm
l_N	Average length of turn	mm
N	Number of turns	
P_{Cu}	Copper (winding) losses	W
P_{trans}	Transferrable power	W
P_V	Relative core losses	mW/g
PF	Performance factor	
Q	Quality factor ($Q = \omega L/R_s = 1/\tan \delta_L$)	
R	Resistance	Ω
R_{Cu}	Copper (winding) resistance ($f = 0$)	Ω
R_h	Hysteresis loss resistance of a core	Ω
ΔR_h	R_h change	Ω
R_i	Internal resistance	Ω
R_p	Parallel loss resistance of a core	Ω
R_s	Series loss resistance of a core	Ω
R_{th}	Thermal resistance	K/W
R_V	Effective loss resistance of a core	Ω
s	Total air gap	mm
T	Temperature	$^{\circ}\text{C}$
ΔT	Temperature difference	K
T_C	Curie temperature	$^{\circ}\text{C}$
t	Time	s
t_v	Pulse duty factor	
$\tan \delta$	Loss factor	
$\tan \delta_L$	Loss factor of coil	
$\tan \delta_r$	(Residual) loss factor at $H \rightarrow 0$	
$\tan \delta_e$	Relative loss factor	
$\tan \delta_h$	Hysteresis loss factor	
$\tan \delta/\mu_i$	Relative loss factor of material at $H \rightarrow 0$	
U	RMS value of voltage	V
\hat{U}	Peak value of voltage	V
V_e	Effective magnetic volume	mm^3
Z	Complex impedance	Ω
Z_n	Normalized impedance $ Z _n = Z /N^2 \times \epsilon (l_e/A_e)$	Ω/mm

Ferrites and accessories
Symbols and terms

Symbol	Meaning	Unit
α	Temperature coefficient (TK)	1/K
α_F	Relative temperature coefficient of material	1/K
α_e	Temperature coefficient of effective permeability	1/K
ϵ_r	Relative permittivity	
Φ	Magnetic flux	Vs
η	Efficiency of a transformer	
η_B	Hysteresis material constant	mT ⁻¹
η_i	Hysteresis core constant	A ⁻¹ H ^{-1/2}
λ_s	Magnetostriction at saturation magnetization	
μ	Relative complex permeability	
μ_0	Magnetic field constant	Vs/Am
μ_a	Relative amplitude permeability	
μ_{app}	Relative apparent permeability	
μ_e	Relative effective permeability	
μ_i	Relative initial permeability	
μ_p'	Relative real (inductive) component of $\bar{\mu}$ (for parallel components)	
μ_p''	Relative imaginary (loss) component of $\bar{\mu}$ (for parallel components)	
μ_r	Relative permeability	
μ_{rev}	Relative reversible permeability	
μ_s'	Relative real (inductive) component of $\bar{\mu}$ (for series components)	
μ_s''	Relative imaginary (loss) component of $\bar{\mu}$ (for series components)	
μ_{tot}	Relative total permeability derived from the static magnetization curve	
ρ	Resistivity	Ωm^{-1}
Σ/A	Magnetic form factor	mm ⁻¹
τ_{Cu}	DC time constant $\tau_{Cu} = L/R_{Cu} = A_L/A_R$	s
ω	Angular frequency; $\omega = 2 \Pi f$	s ⁻¹

All dimensions are given in mm.

SMD Surface-mount device

Important notes

The following applies to all products named in this publication:

1. Some parts of this publication contain **statements about the suitability of our products for certain areas of application**. These statements are based on our knowledge of typical requirements that are often placed on our products in the areas of application concerned. We nevertheless expressly point out **that such statements cannot be regarded as binding statements about the suitability of our products for a particular customer application**. As a rule, EPCOS is either unfamiliar with individual customer applications or less familiar with them than the customers themselves. For these reasons, it is always ultimately incumbent on the customer to check and decide whether an EPCOS product with the properties described in the product specification is suitable for use in a particular customer application.
2. We also point out that **in individual cases, a malfunction of electronic components or failure before the end of their usual service life cannot be completely ruled out in the current state of the art, even if they are operated as specified**. In customer applications requiring a very high level of operational safety and especially in customer applications in which the malfunction or failure of an electronic component could endanger human life or health (e.g. in accident prevention or life-saving systems), it must therefore be ensured by means of suitable design of the customer application or other action taken by the customer (e.g. installation of protective circuitry or redundancy) that no injury or damage is sustained by third parties in the event of malfunction or failure of an electronic component.
3. **The warnings, cautions and product-specific notes must be observed.**
4. In order to satisfy certain technical requirements, **some of the products described in this publication may contain substances subject to restrictions in certain jurisdictions (e.g. because they are classed as hazardous)**. Useful information on this will be found in our Material Data Sheets on the Internet (www.epcos.com/material). Should you have any more detailed questions, please contact our sales offices.
5. We constantly strive to improve our products. Consequently, **the products described in this publication may change from time to time**. The same is true of the corresponding product specifications. Please check therefore to what extent product descriptions and specifications contained in this publication are still applicable before or when you place an order.

We also **reserve the right to discontinue production and delivery of products**. Consequently, we cannot guarantee that all products named in this publication will always be available. The aforementioned does not apply in the case of individual agreements deviating from the foregoing for customer-specific products.

6. Unless otherwise agreed in individual contracts, **all orders are subject to the current version of the “General Terms of Delivery for Products and Services in the Electrical Industry” published by the German Electrical and Electronics Industry Association (ZVEI)**.
7. The trade names EPCOS, CeraCharge, CeraDiode, CeraLink, CeraPad, CeraPlas, CSMP, CTVS, DeltaCap, DigiSiMic, ExoCore, FilterCap, FormFit, LeaXield, MiniBlue, MiniCell, MKD, MKK, MotorCap, PCC, PhaseCap, PhaseCube, PhaseMod, PhiCap, PowerHap, PQSine, PQvar, SIFERRIT, SIFI, SIKOREL, SilverCap, SIMDAD, SiMic, SIMID, SineFormer, SIOV, ThermoFuse, WindCap are **trademarks registered or pending** in Europe and in other countries. Further information will be found on the Internet at www.epcos.com/trademarks.

X-ON Electronics

Largest Supplier of Electrical and Electronic Components

Click to view similar products for [Ferrite Cores & Accessories](#) category:

Click to view products by [TDK](#) manufacturer:

Other Similar products are found below :

[B65512C0000T001](#) [B65522B0000T001](#) [B65549E4X23](#) [B65659F0003X023](#) [B65659F4X23](#) [B65665C0004X000](#) [B65679E3X22](#)

[B65705B0003X000](#) [B65804C2005X000](#) [B65812B3003X22](#) [B65814B2005X000](#) [B65840B1006D001](#) [B65840B1006D002](#)

[B65878E0012D001](#) [B66206A2001X000](#) [B66206J1106T1](#) [B66252BM1](#) [B66288F2204X000](#) [B66306C1010T2](#) [B66341G0000X127](#)

[B66390A1016T001](#) [B67348A1X27](#) [B62152P0007X030](#) [B65518D2001X000](#) [B65535B0003X000](#) [B65539C1003X1](#) [B65542A5000X](#)

[B65655B0009X000](#) [B65687A1000T001](#) [B65714K1020T001](#) [B65734B1000T001](#) [B65734B1000T1](#) [B65804B6010T1](#) [B65814N1008D002](#)

[B65816N1011D1](#) [B65844W1010D001](#) [B65848D1010D1](#) [B65848S2000X](#) [B65884E0012D001](#) [B66202A2010X000](#) [B66202B1106T001](#)

[B66206B1110T001](#) [B66208K1009T001](#) [B66208X1010T001](#) [B66291P0000X187](#) [B66387G1200X187](#) [B66461P0000X187](#) [B67410A72X27](#)

[UECESDFPL20150](#) [UECESDR14C2000](#)