

Disc type capacitors with leads  
High voltage ceramic capacitors, commercial grade, safety standard approved



# CD45 series



## FEATURES

- Compliant with IEC and the safety standards of various countries.
- CD45 series meets reinforced insulation's safety standards. Since the withstand voltage is 4,000V AC, single-unit configuration is available for European class II devices.
- Flame-resistant reinforced outer insulation prevents fires, electrical shock, and other potential hazards.
- Conform to RoHS directive due to lead(Pb) free of lead-wire and internal solder material.
- Compatible with halogen-free external resin coating.

## APPLICATION

Y capacitor for AC adapter, charger, power supplies

## PART NUMBER CONSTRUCTION

CD45	-E	2GA	102	M	-	□	K	A			
Series name*	Temperature characteristics	Rated voltage		Nominal capacitance		Capacitance tolerance		Lead-wire type	Application classification	Internal code	
SL	+350 to -1,000ppm/°C	2GA	X1: 440V AC Y1: 400V AC	100	10pF	J	±5%	G	Long lead	K	Safety standard approved
-B	±10%			102	1,000pF	K	±10%	N	Short lead		
-E	+20, -55%			222	2,200pF	M	±20%	V	Taping		
										A	Halogen-free

\* Please refer to P-3 about the product dimensions.

## OPERATING TEMPERATURE RANGE

Temperature characteristics	Operating temperature (°C)	Storage temperature (°C)*
SL	-40 to 125	-40 to 125
B	-40 to 125	-40 to 125
E	-40 to 125	-40 to 125

The maximum operating temperature of +125°C includes capacitor self-generated heat of up to 20°C.

\* After capacitor is mounted on board, the storage temperature range is applied.

## STANDARD LEAD-WIRE SHAPES

Dimensions in mm

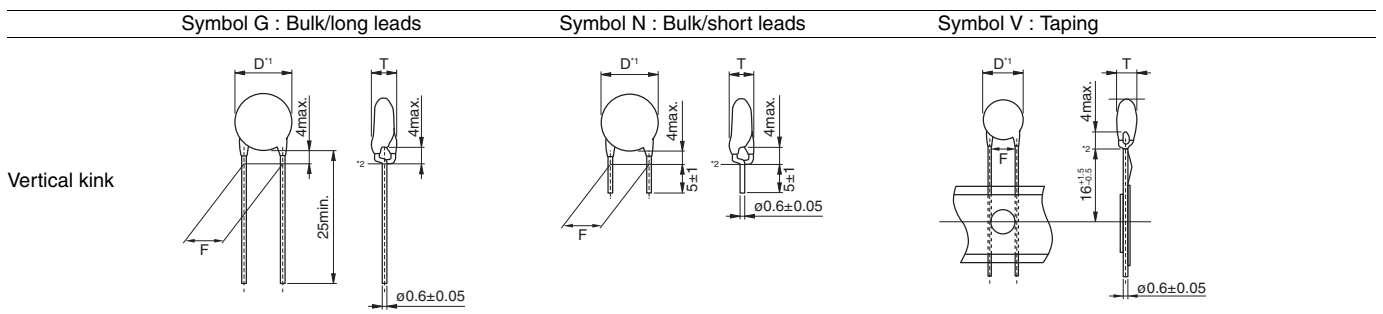

TDK's standard product is vertical kink. TDK recommends short leads for bulk products.

\*1 Body diameter (D) is reference value if D is smaller than maximum dimension of lead to lead distance (F).

\*2 Coating on leads shall not extend beyond the bottom of vertical kink.

- RoHS Directive Compliant Product: See the following for more details. <http://product.tdk.com/en/environment/rohs/>
- Halogen-free: Indicate that Cl content is less than 900ppm, Br content is less than 900ppm, and that the total Cl and Br content is less than 1500ppm.

# Overview of CD45 series

## CERTIFIED STATUS OF VARIOUS COUNTRIES

Safety standard	IEC standard No.	Standard No.	Temperature characteristics	Sub-class	Rated voltage	Approval report No.*	
						Taiwan	Xiamen
ENEC		EN 60384-14				ENEC-01048	
UL		UL60384-14				E37861	
cUL/CSA		AS3250		X1, Y1	X1:440V AC Y1:400V AC	CS6268	
SAA	IEC 60384-14	IEC 60384-14	SL,B,E			CQC14001112767	CQC14001112447
CQC		IEC 60384-14				SZ03001-12002	SU03047-12002
KTL		K60384-14		X1 Y1	440V AC 400V AC	SZ03001-12004	SU03047-12004

\* Certificate numbers shall be changed owing to the revisions of the related standards and renewal of certificate.

## RECOMMENDED FLOW PROFILE

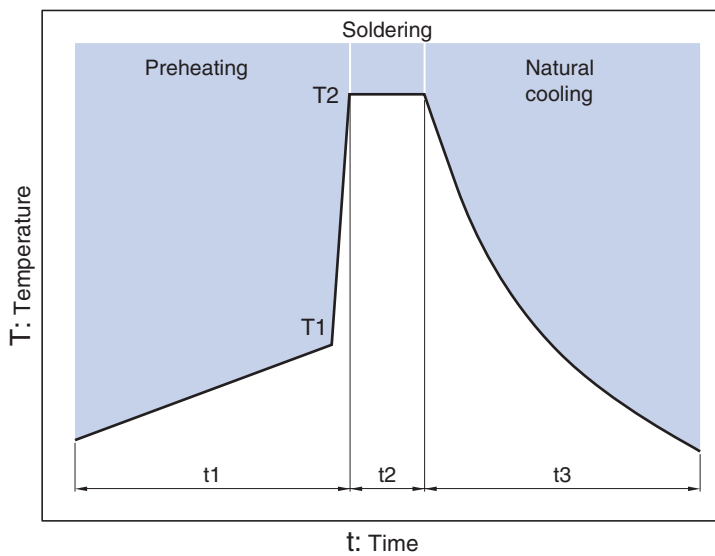

Preheating		Peak		Natural cooling
Temp.	Time	Temp.	Time	Time
T1	t1	T2	t2	t3
110°C min.	30 to 60s.	260°C	Within 10s.	Over 60s.

## CD45 type

## MARKINGS

Item	Markings	Description	Marking examples
1. Series	CD	CD45 series	<p>(Marking position is reference.)</p>
2. Nominal capacitance	10	10pF	
3. Capacitance tolerance	J	±5%	
4. Rated voltage Eac	440~X1 400~Y1	X1:440V AC Y1:400V AC	
5. TDK's trademark		Production base code	
6. Date code	04	2020.4*	

\* Year and month of production: last digit of year + month denoted by 1, 2, 3, 4, 5, 6, 7, 8, 9, O (October), N (November), or D (December).

\*The expression has become simplified due to a revision in the standards.

## RATED VOLTAGE Eac: X1=440V, Y1=400V

## CAPACITANCE AND DIMENSIONS

Temperature characteristics	Capacitance	Capacitance tolerance	Dimensions (mm)				Part numbers		
			Dmax. *	Tmax.	F (applied to bulk)	F (applied to taping)	Bulk/long leads (Symbol: G)	Bulk/short leads (Symbol: N)	Taping (Symbol: V)
SL	10pF	±5%	(7.0)	6.0	10+2,-1	10±1	<a href="#">CD45SL2GA100J-GKA</a>	<a href="#">CD45SL2GA100J-NKA</a>	<a href="#">CD45SL2GA100J-VKA</a>
SL	15pF	±5%	(7.0)	6.0	10+2,-1	10±1	<a href="#">CD45SL2GA150J-GKA</a>	<a href="#">CD45SL2GA150J-NKA</a>	<a href="#">CD45SL2GA150J-VKA</a>
SL	22pF	±5%	(7.0)	6.0	10+2,-1	10±1	<a href="#">CD45SL2GA220J-GKA</a>	<a href="#">CD45SL2GA220J-NKA</a>	<a href="#">CD45SL2GA220J-VKA</a>
SL	33pF	±5%	(7.0)	6.0	10+2,-1	10±1	<a href="#">CD45SL2GA330J-GKA</a>	<a href="#">CD45SL2GA330J-NKA</a>	<a href="#">CD45SL2GA330J-VKA</a>
SL	47pF	±5%	(8.0)	6.0	10+2,-1	10±1	<a href="#">CD45SL2GA470J-GKA</a>	<a href="#">CD45SL2GA470J-NKA</a>	<a href="#">CD45SL2GA470J-VKA</a>
SL	68pF	±5%	(9.0)	6.0	10+2,-1	10±1	<a href="#">CD45SL2GA680J-GKA</a>	<a href="#">CD45SL2GA680J-NKA</a>	<a href="#">CD45SL2GA680J-VKA</a>
B	100pF	±10%	(6.5)	6.0	10+2,-1	10±1	<a href="#">CD45-B2GA101K-GKA</a>	<a href="#">CD45-B2GA101K-NKA</a>	<a href="#">CD45-B2GA101K-VKA</a>
B	150pF	±10%	(6.5)	6.0	10+2,-1	10±1	<a href="#">CD45-B2GA151K-GKA</a>	<a href="#">CD45-B2GA151K-NKA</a>	<a href="#">CD45-B2GA151K-VKA</a>
B	220pF	±10%	(6.5)	6.0	10+2,-1	10±1	<a href="#">CD45-B2GA221K-GKA</a>	<a href="#">CD45-B2GA221K-NKA</a>	<a href="#">CD45-B2GA221K-VKA</a>
B	330pF	±10%	(7.0)	6.0	10+2,-1	10±1	<a href="#">CD45-B2GA331K-GKA</a>	<a href="#">CD45-B2GA331K-NKA</a>	<a href="#">CD45-B2GA331K-VKA</a>
B	470pF	±10%	(8.0)	6.0	10+2,-1	10±1	<a href="#">CD45-B2GA471K-GKA</a>	<a href="#">CD45-B2GA471K-NKA</a>	<a href="#">CD45-B2GA471K-VKA</a>
E	680pF	±20%	(6.5)	6.0	10+2,-1	10±1	<a href="#">CD45-E2GA681M-GKA</a>	<a href="#">CD45-E2GA681M-NKA</a>	<a href="#">CD45-E2GA681M-VKA</a>
E	1,000pF	±20%	(7.0)	6.0	10+2,-1	10±1	<a href="#">CD45-E2GA102M-GKA</a>	<a href="#">CD45-E2GA102M-NKA</a>	<a href="#">CD45-E2GA102M-VKA</a>
E	1,500pF	±20%	(8.0)	6.0	10+2,-1	10±1	<a href="#">CD45-E2GA152M-GKA</a>	<a href="#">CD45-E2GA152M-NKA</a>	<a href="#">CD45-E2GA152M-VKA</a>
E	2,200pF	±20%	(9.0)	6.0	10+2,-1	10±1	<a href="#">CD45-E2GA222M-GKA</a>	<a href="#">CD45-E2GA222M-NKA</a>	<a href="#">CD45-E2GA222M-VKA</a>
E	3,300pF	±20%	(11.0)	6.0	10+2,-1	10±1	<a href="#">CD45-E2GA332M-GKA</a>	<a href="#">CD45-E2GA332M-NKA</a>	<a href="#">CD45-E2GA332M-VKA</a>
E	4,700pF	±20%	13.0	6.0	10+2,-1	10±1	<a href="#">CD45-E2GA472M-GKA</a>	<a href="#">CD45-E2GA472M-NKA</a>	<a href="#">CD45-E2GA472M-VKA</a>

\* The values in parentheses "( )" are reference values.

Click the part number for details.

• Please refer to p-4 about the taping dimensions.

• For more information about products with other capacitance or other data, please contact us.

Please be sure to request delivery specifications that provide further details on the features and specifications of the products for proper and safe use. (3/5)  
Please note that the contents may change without any prior notice due to reasons such as upgrading.

20200909

leaddisc\_commercial\_cd45\_en

## CD45 type

## TAPING DIMENSIONS

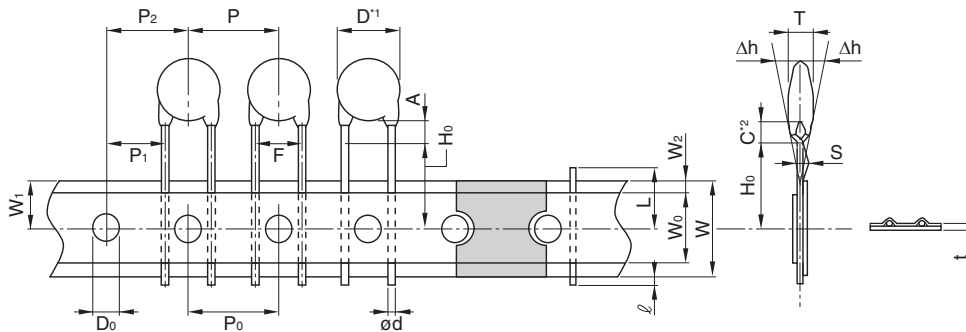

Item	Symbols	Dimensions (mm)	Remarks
Body diameter	D	Refer to P-3	*1 Body diameter (D) is reference value if D is smaller than maximum dimension of lead to lead distance (F).
Body thickness	T	Refer to P-3	
Lead-wire diameter	ød	0.6±0.05	
Pitch of component	P	15.0±1.0	Including the slant of body
Feed hole pitch	P <sub>0</sub>	15.0±0.3	Excepting the tape splicing part
Feed hole center to lead-wire	P <sub>1</sub>	10.0±0.7	
Feed hole center to component center	P <sub>2</sub>	15.0±1.3	Including the slanting body due to bending lead-wire
Lead-to lead distance	F	10.0 ±1.0	Measuring point is bottom kink
Component alignment	Δh	0 ±2.0	Including the slanting body due to bending lead-wire
Carrier tape width	W	18.0+1.0,-0.5	
Adhesive tape width	W <sub>0</sub>	10.0 Min.	
Hole position	W <sub>1</sub>	9.0±0.5	
Adhesive tape position	W <sub>2</sub>	4.0 Max.	Adhesive tape do not stick out the tape
Bottom of kink from tape center	H <sub>0</sub>	16.0+1.5,-0.5	
Lead-wire protrusion	ℓ	1.0 Max.	
Feed hole diameter	D <sub>0</sub>	4.0±0.2	
Carrier tape thickness (Including adhesive tape)	t	0.6±0.3	Including adhesive tape
Length of snapped lead-wire	L	11.0 Max.	
Coating on lead-wire	C	4.0 Max.	*2 Coating on leads shall not extend beyond the bottom of vertical kink.
Height of kink	A	4.0 Max.	Measuring point is bottom kink
Spring action	S	2.0 Max.	

## AMMO PACK INNER BOX SIZE

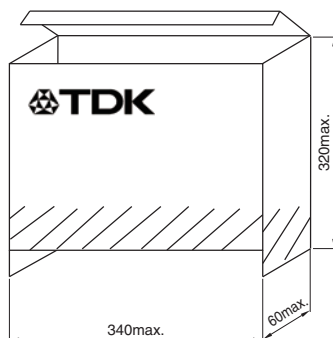

Dimensions in mm

## PACKAGE QUANTITY

Type	Package quantity	
	Bulk (pieces / bag)	Taping (pieces / box)
CD45	1000	1000

## REMINDERS FOR USING THESE PRODUCTS

Before using these products, be sure to request the delivery specifications.

### SAFETY REMINDERS

Please pay sufficient attention to the warnings for safe designing when using this products.

#### REMINDERS

- Do not use or store in locations where there are conditions such as gas corrosion (salt, acid, alkali, etc.).
- Before soldering, be sure to preheat components.  
The preheating temperature should be set so that the temperature difference between the solder temperature and product temperature does not exceed 150°C.
- Soldering corrections after mounting should be within the range of the conditions determined in the specifications.  
If overheated, a short circuit, performance deterioration, or lifespan shortening may occur.
- Self heating (temperature increase) occurs when the power is turned ON, so the tolerance should be sufficient for the set thermal design.
- Do not use for a purpose outside of the contents regulated in the delivery specifications.
- The products listed on this catalog are intended for use in general electronic equipment (AV equipment, telecommunications equipment, home appliances, amusement equipment, computer equipment, personal equipment, office equipment, measurement equipment, industrial robots) under a normal operation and use condition.  
The products are not designed or warranted to meet the requirements of the applications listed below, whose performance and/or quality require a more stringent level of safety or reliability, or whose failure, malfunction or trouble could cause serious damage to society, person or property.  
If you intend to use the products in the applications listed below or if you have special requirements exceeding the range or conditions set forth in the each catalog, please contact us.

- |   |  |
|---|--|
| (1) Aerospace/aviation equipment                                  | (8) Public information-processing equipment                                  |
| (2) Transportation equipment (cars, electric trains, ships, etc.) | (9) Military equipment   |
| (3) Medical equipment   | (10) Electric heating apparatus, burning equipment                           |
| (4) Power-generation control equipment                            | (11) Disaster prevention/crime prevention equipment                          |
| (5) Atomic energy-related equipment                               | (12) Safety equipment  |
| (6) Seabed equipment  | (13) Other applications that are not considered general-purpose applications |
| (7) Transportation control equipment                              |  |

- Please refer to the guideline of notabilia for fixed ceramic capacitors issued by JEITA(Japan Electronics and Information Technology Association, EIAJ RCR-2335).

This guideline describes general precautions\* for using fixed ceramic capacitors. Please carefully confirm it and use capacitors safely.

\* Items for check, explanation/reason/concrete example and failure examples, etc.

When designing your equipment even for general-purpose applications, you are kindly requested to take into consideration securing protection circuit/device or providing backup circuits in your equipment.

## X-ON Electronics

Largest Supplier of Electrical and Electronic Components

*Click to view similar products for [Safety Capacitors](#) category:*

*Click to view products by [TDK](#) manufacturer:*

Other Similar products are found below :

[B32022B3223K026](#) [B32912A3104K026](#) [B81123C1102M003](#) [MKPY2-.02230020P15](#) [46KN333000M1M](#) [46KN422000P0M](#)

[F1778433K2FBB0](#) [46KR422000M1K](#) [MP1125KRE6RLC](#) [MP2683KGC2XLC](#) [MP2124KGC3XLC](#) [MP2684KGD4XLC](#) [MP2474KGE1XLC](#)

[46KF268000M1M](#) [46KI3150NDM2M](#) [PHE840MD6220MD13R30](#) [PHE840MY6470MD14R06](#) [PHE845VD5470MR06](#) [R463N4100ZAM1K](#)

[MKPX2R-1/400/10P27](#) [YP500101K040B20C2P](#) [YU0AH222M090DAMD0B](#) [LS1808N102K302NX080TM](#) [VY2103M59Y5VS63V7](#)

[CY1471KE1IEB46X2A2](#) [CY1222ME5IEE48O2A2](#) [MPX474K31DTEV158G0](#) [Y2560K-D1I-B4-AC250V](#) [HMF222MG3BW](#)

[CY1471ME19EE45W2A2](#) [MPX104K31D2KN158HF](#) [MPX224K31D2KN158G0](#) [PX104K2W1502](#) [C47S1472K60C000](#) [MP2224K32C5J6LC](#)

[H102M050FQ55250L750A](#) [MP2474K32D6R8LC](#) [MP2224K32C3J6LC](#) [MP2104K32C3J6LC](#) [PX334K2C1006](#) [YU0AC222M080L20C7B](#)

[MP2473K27B2X6LC](#) [MP2224K32D4J8LC](#) [MP2684K32D6T8LC](#) [ST3Y1Y5U332M500VAC](#) [ST3Y1Y5V472M500VAC](#)

[MP2474K32D4X8LC](#) [MP2474K32D4J8LC](#) [YU0AH332M110L4EB0B](#) [CY1681ME1IEE45S2A2](#)