

SPECIFICATION

SPEC NO. TFA3NAA00557

DATE : Apr.24th,2020

To

Foxtar

CUSTOMER'S PRODUCT NAME

TDK'S PRODUCT NAME

DEA203600BT-2265B3-H

RECEIPT CONFIRMATION

DATE : YEAR MONTH DAY

TDK Corporation

Sales

Electronic Components Sales &
Marketing Group

Engineering

Electronic Components Business Company
Communication Devices Business Group

APPROVED	PERSON IN CHARGE

APPROVED	CHECKED	PERSON IN CHARGE
<i>H. Matsubara</i>	<i>S. Mochizuka</i>	<i>H. Ashida</i>

Band Pass Filter Specification

(TDK Part Number : DEA203600BT-2265B3-H)

1. Marking

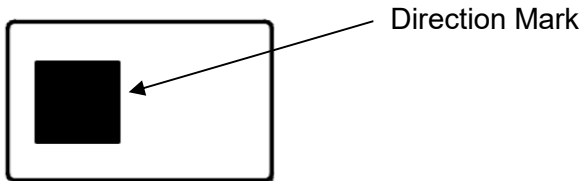

2. Mechanical Outline

2-1 Package

Package:	Surface mount package
Delivery Medium:	Tape on reel
Soldering Method:	IR-reflow
Size:	2.00 x 1.25 mm typ.
Height:	0.65 mm max.

Mechanical Dimensions

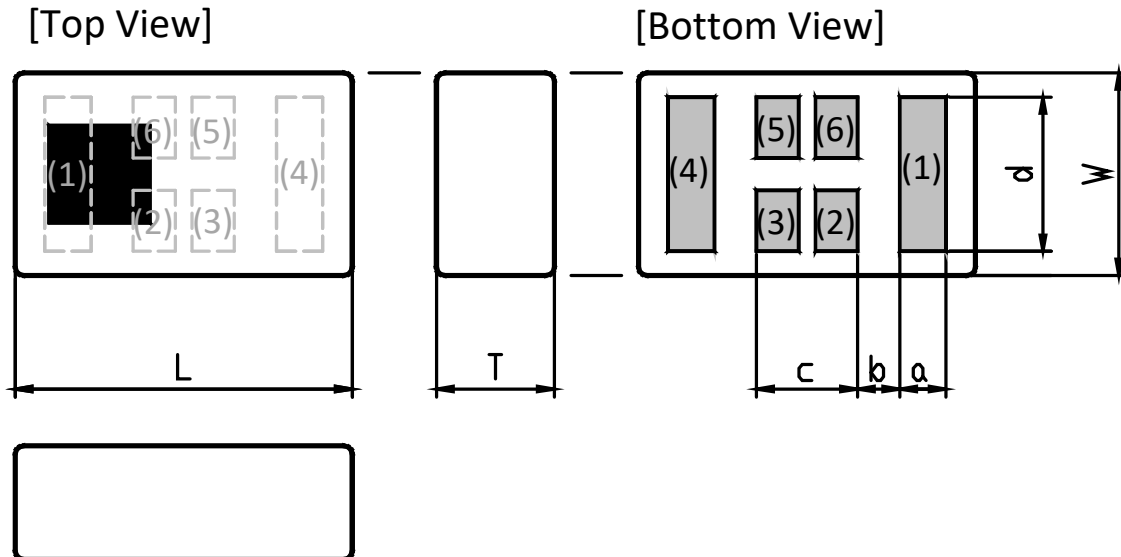

Dimensions (mm)

L	W	T	a	b	c	d
2.00	1.25	0.65	0.28	0.25	0.60	0.95
+/-0.15	+/-0.10	Max	+/-0.10	+/-0.10	+/-0.10	+/-0.15

Terminal functions

(1)	Input Port
(2)	GND
(3)	GND

(4)	Output Port
(5)	GND
(6)	GND

2-2 Coplanarity

0.05 mm max. difference in Z-direction as follows

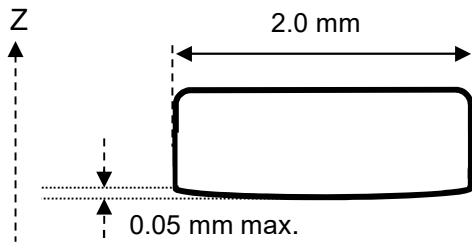

Coplanarity measurement method

Coplanarity = T1-T2

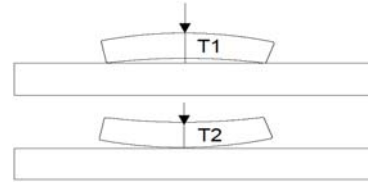

Each terminal extends the full of the product. Hence any coplanarity deviation between terminals is due to curvature in the substrate. TDK guarantees that the edge of each terminal is within 0.05 mm of the horizontal plane.

3. Environment (Temperature & Humidity)

3-1 Operating & Storage Condition

Storage Temperature Range : -40 ~ +90 °C
 Operating Temperature Range : -40 ~ +90 °C
 Humidity : 0 ~ 90 %RH (Max. wet bulb temperature 38 °C)

3-2 Storage Condition before Soldering

Temperature : +5 ~ +30 °C
 Humidity : 20 ~ 70 %RH
 Term of Storage : Within 12 months (After the delivery) *
 Baking : Unnecessary

* After peeling off cover tape, do not keep exposing the products to the open air.

For the products stored longer than 12 months, confirm their terminals and solderability before use.

3-3 Moisture Sensitivity Level

Equal to Level 1

4. Electrical Specification

4-1 Electrical Characteristics

Parameter	Frequency (MHz)	TDK Spec		
		Min.	Typ.	Max.
Insertion Loss (dB)	3300 to 3400	-	1.05	1.50
	3400 to 3800	-	0.79	0.90
	3800 to 4100	-	1.23	2.00
Insertion Loss (dB) (-40 to +90 °C)	3300 to 3400	-	-	1.80
	3400 to 3800	-	-	1.10
	3800 to 4100	-	-	2.30
Return Loss (dB)	3300 to 3400	12	20.6	-
	3400 to 3800	12	18.9	-
	3800 to 4100	8	13.5	-
Attenuation (dB)	500 to 960	38	39.5	-
	1427 to 1511	39	41.0	-
	1695 to 2170	40	44.9	-
	2300 to 2400	38	40.3	-
	2400 to 2500	36	39.1	-
	2500 to 2690	36	39.1	-
	2700 to 3150	0.5	3.6	-
	4400 to 4700	5	10.3	-
	4700 to 4800	30	41.0	-
	4800 to 4900	35	39.2	-
	4900 to 5150	32	39.2	-
	5150 to 5925	37	42.7	-
	6250 to 6550	38	41.8	-
	6800 to 7200	35	39.3	-
	7200 to 9000	35	38.5	-
10200 to 10800	32	37.9	-	
13600 to 15200	26	30.3	-	
Characteristic Impedance (ohm)		50 (Nominal)		

Ta = +25+/-5°C

4-2 Maximum Ratings

Parameter	TDK Spec		Conditions
	Min.	Max.	
Power Handling (W) ^{*1}		2	CW
Human Body Model : HBM @Each Port (V)	-1000	1000	100pF / 1500ohm
Machine Model : MM @Each Port (V)	-150	150	200pF / 0ohm
Charged Device Model : CDM @Each Port (V)	-500	500	Relative humidity : 60%RH max

*1 : Refer to 3GPP TS 38.101-1 V15.2.0

5. Typical Electrical Characteristics

Insertion Loss

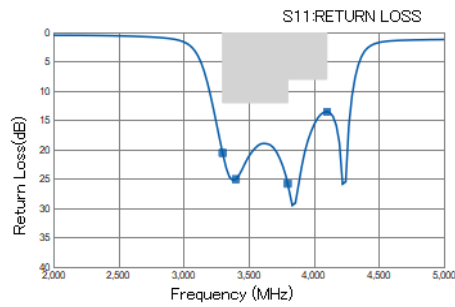

P/N	DEA203600BT- 2265E3- H_Ver1_ON20180511
3300	20.55
3400	25.04
3800	25.78
4100	13.50

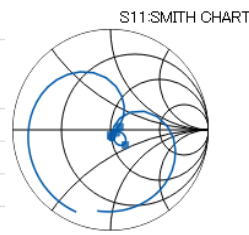

P/N	DEA203600BT- 2265E3- H_Ver1_ON20180511
3300	59.32 / 4.31
3400	55.51 / -2.11
3800	48.92 / -4.98
4100	63.88 / -20.12

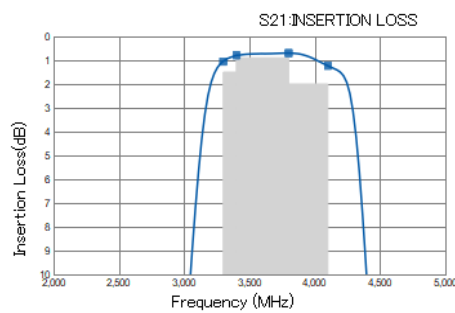

P/N	DEA203600BT- 2265E3- H_Ver1_ON20180511
3300	1.06
3400	0.79
3800	0.70
4100	1.23

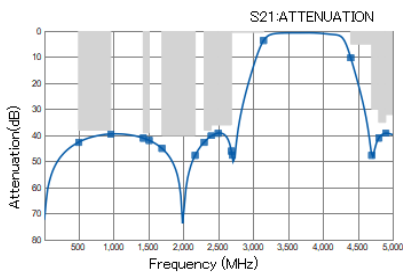

P/N	DEA203600BT- 2265E3- H_Ver1_ON20180511
500	42.62
960	39.47
1427	41.06
1511	41.92
1695	44.97
2170	47.64
2300	42.61
2400	40.26
2500	39.13
2690	46.03
2700	47.52
3150	3.62
4400	10.31
4700	47.62
4800	41.01
4900	39.19

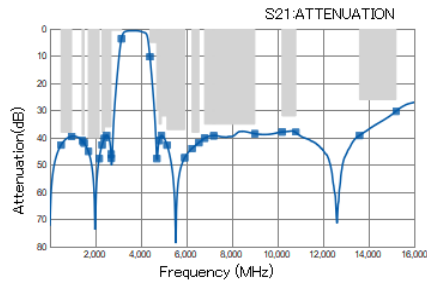

5150	42.66
5925	47.34
6250	43.90
6550	41.76
6800	40.14
7200	39.27
9000	38.52
10200	37.86
10800	38.01
13600	39.11
15200	30.25

6. Test Circuit

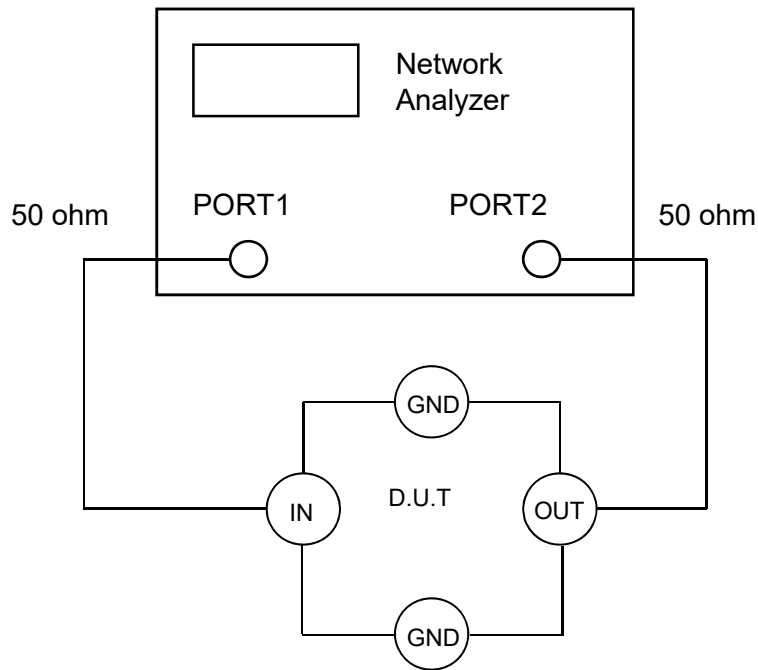

Note 1: The Port Extension function on the Network Analyzer is used to extend the calibration plane to the DUT terminals.

Note 2: Loss in the PCB traces is compensated for by measurement data taken on a PCB Thru' line.

7. Evaluation PCB and Land Pattern

RECOMMENDED LAND PATTERN

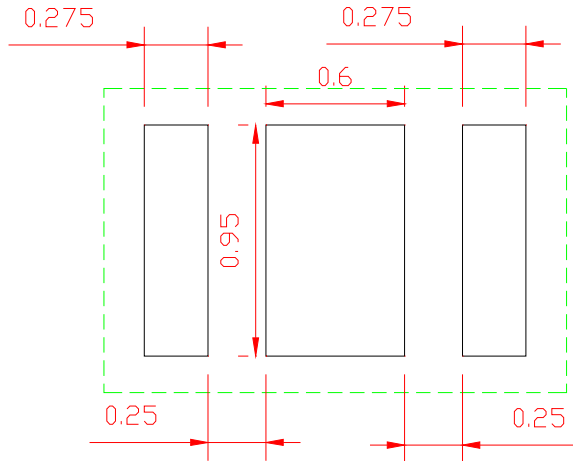

Unit : mm

EVALUATION BOARD

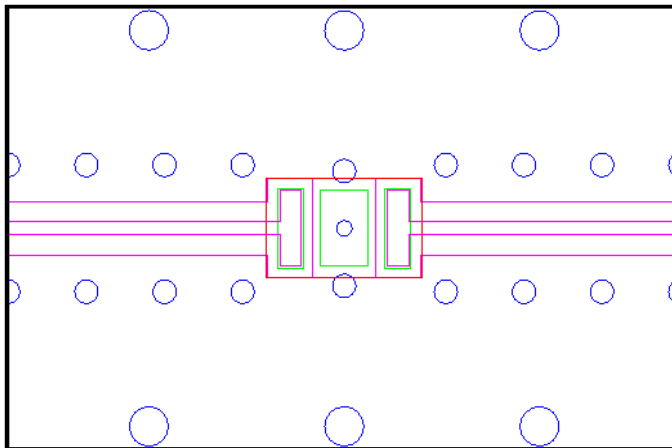

- Thru hole
- Resist
- Surface Pattern
- DUT (BPF)

Material, Layer	Thickness
Top Resist	Resist
Copper Surface Pattern	0.035mm
FR-4	0.10mm
Copper Inner GND	0.018mm
FR-4	0.30mm
Copper Bottom GND	0.035mm

8. Environmental and Quality Proposal

This product satisfies the electrical specification after the following tests.
(When measured after two hours in normal conditions)

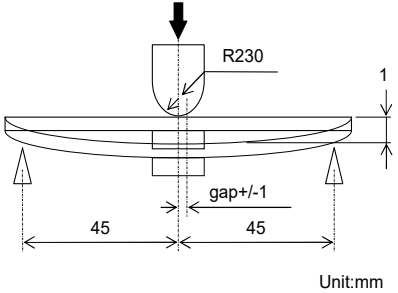
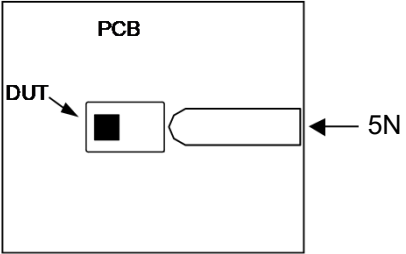
Temperature Characteristics	All data initially taken at +25°C, then repeated at -40°C and again at +90 °C
Heat Proof	+90 +/- 2 °C for 1000 hours
Cold Proof	-40 +/- 2 °C for 500 hours
Moisture Proof	+60 +/- 2 °C, 90~95%RH for 1000 hours
Heat Shock	-40 ~ +90 °C for 320 cycles, each cycle being 30 min
Vibration	10-500Hz vibration frequency (10G Max.) with 1.52mmp-p amplitude for two hours in x,y,z directions
Mechanical Shock	1.Acceleration 1000m/s ² 2.Direction X, Y, Z ,X',Y',Z',axes 3.Time 6ms duration and 3 times in each direction
Solderability	The dipped surface of the terminal shall be at least 75% covered with solder after dipped in solder bath of 245+/- 3 °C for 3 +/- 0.5 sec. Remark solder: Sn-3.0Ag-0.5Cu Remark flux: Rosin 25%, Alcohol 75%
Solder Heat Shock	It shall be possible to hot air reflow the components three times with a temperature profile shown below.
Drop Shock	Dropped onto steel plate or concrete from 100cm height three times.
Bending	<p>Solder specimen components on the test printed circuit board (L:100 x W:40 x T:0.8mm) in appended recommended PCB pattern. Apply the load in direction of the arrow until bending reaches 1mm for 5+/-1 sec.</p> 
Board Adhesion (Push Test)	<p>Solder specimen components on the test printed circuit board (L:100 x W:40 x T:0.8mm) in appended recommended PCB pattern. Apply the load in direction of the arrow until 5N for 5+/-1 sec.</p> 

9. Recommended Reflowing Temperature Profile

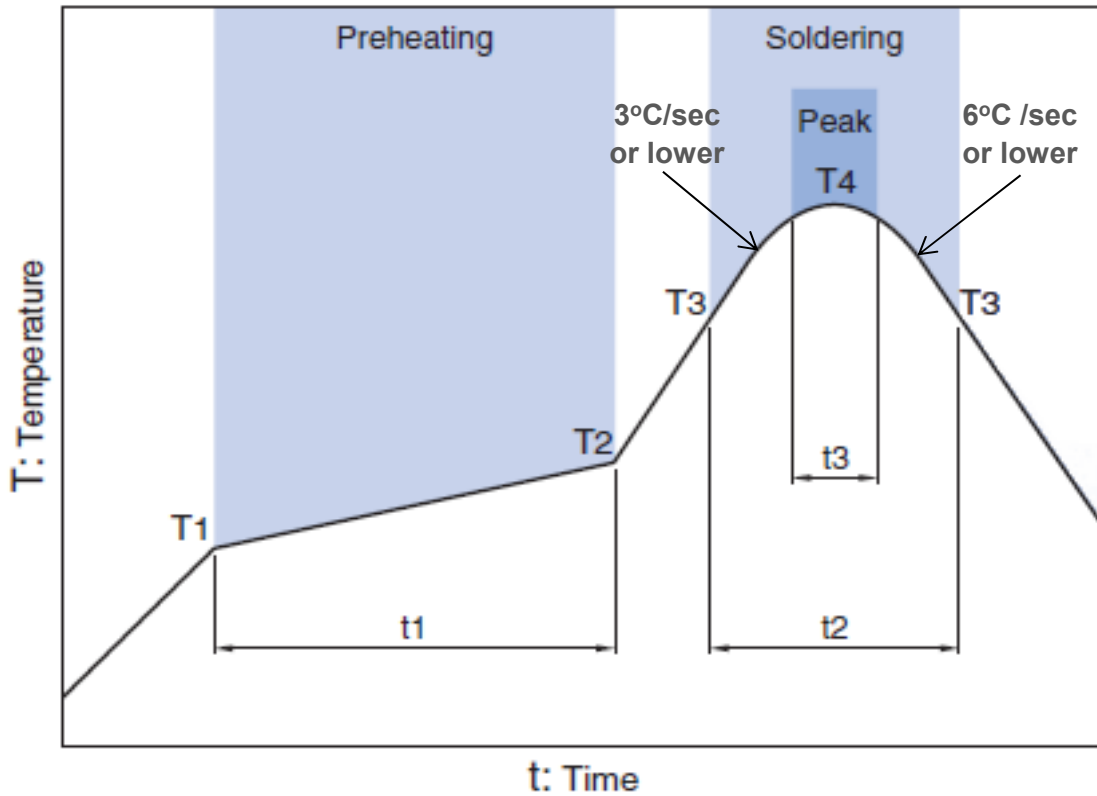

Preheating			Soldering			
			Critical zone (T3 to T4)		Peak	
Temp.		Time	Temp.	Time	Temp.	Time
T1	T2	t1	T3	t2	T4	t3 *
150°C	200°C	60 to 120sec	217°C	60 to 120sec	240 to 260°C	30 sec Max

* t3 : Time within 5°C of actual peak temperature.

The maximum number of reflow is 3.

Note: Lead free solder is recommended.

Recommended solder is Sn-3.0Ag-0.5Cu. (M705 by Senju Metal Industry)

10. Packing

10-1 Carrier Tape

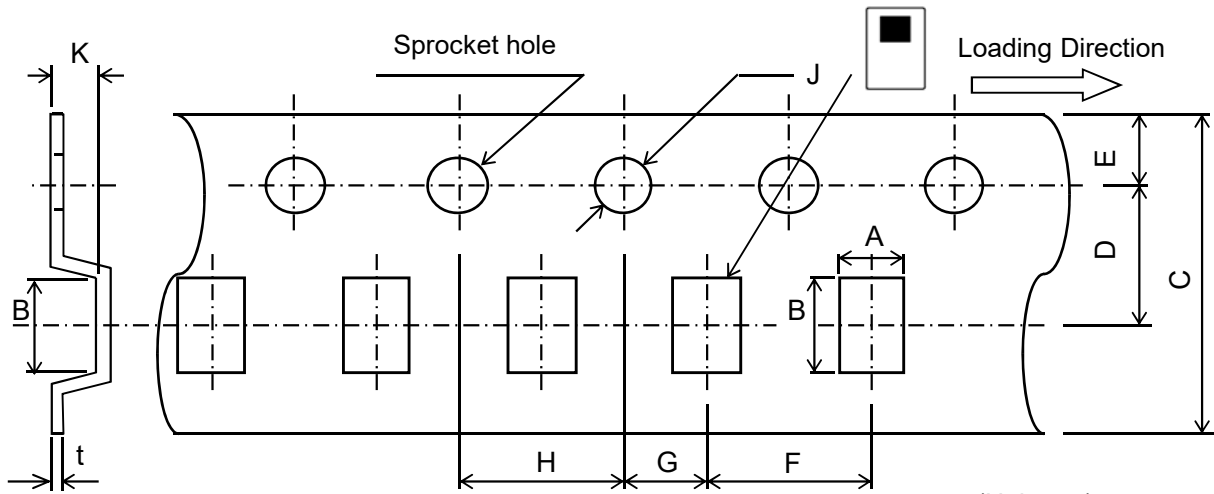

(Unit:mm)

A	B	C	D	E	F	G	H	J	K	t
1.45	2.2	8.0	3.5	1.75	4.0	2.0	4.0	1.5	0.8	0.25
+/-0.05	+/-0.05	+0.3/-0.1	+/-0.05	+/-0.1	+/-0.1	+/-0.05	+/-0.1	+0.1/-0	MAX	+/-0.05

10-2 Reel Dimensions

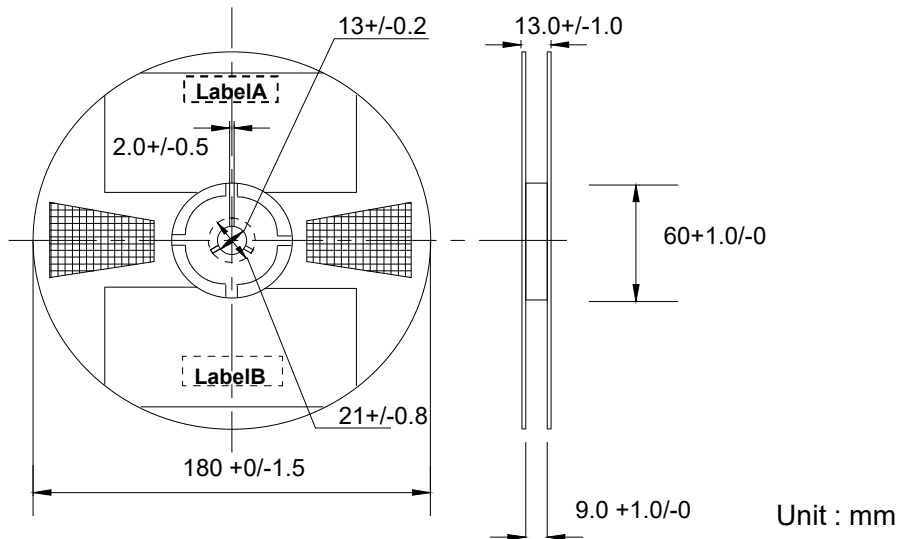

10-3 Standard Reel Packaging Quantities

2000pcs./reel

11. Other

11-1 Caution

The products listed on this specification sheet are intended for use in general electronic equipment (AV equipment, telecommunications equipment, home appliances, amusement equipment, computer equipment, personal equipment, office equipment, measurement equipment, industrial robots) under a normal operation and use condition.

The products are not designed or warranted to meet the requirements of the applications listed below, whose performance and/or quality require a more stringent level of safety or reliability, or whose failure, malfunction or trouble could cause serious damage to society, person or property. Please understand that we are not responsible for any damage or liability caused by use of the products in any of the applications below or for any other use exceeding the range or conditions set forth in this specification sheet.

- Aerospace/Aviation equipment
- Transportation equipment (cars, electric trains, ships, etc.)
- Medical equipment
- Power-generation control equipment
- Atomic energy-related equipment
- Seabed equipment
- Transportation control equipment
- Public information-processing equipment
- Military equipment
- Electric heating apparatus, burning equipment
- Disaster prevention/crime prevention equipment
- Safety equipment
- Other applications that are not considered general-purpose applications

When designing your equipment even for general-purpose applications, you are kindly requested to take into consideration securing protection circuit/device or providing backup circuits in your equipment.

11-2 Storage Conditions

Do not store the product in following conditions, performance may deteriorate.

- Exposure to atmosphere containing corrosive gas, such as Cl₂, NH₃, SO_x and NO_x
- Exposure to volatile or combustible gases
- Exposure to excessive dust
- Exposure to direct sunlight
- Exposure to direct water splashing
- Exposure to freezing temperature
- Exposure to dew condensation due to high humidity

11-3 Product Origin

1. TDK Akita Corporation, Akita, Japan
2. TDK Dalian Corporation, Dalian, China

X-ON Electronics

Largest Supplier of Electrical and Electronic Components

Click to view similar products for [tdk manufacturer:](#)

Other Similar products are found below :

[VLF5012ST-1R0N2R5](#) [R14493](#) [SWS1000L-24/BL](#) [CXA-2115](#) [MCZ1210AH301L2T](#) [78P7200-IH/F](#) [MLP2012S1R5TT](#) [ACH3218-682-TD01](#) [ACT45B-KIT](#) [NL565050T-822J-PF](#) [C1005JB1H471K050BA](#) [C1608CH1H151J080AA](#) [C2012JB1H105K125AB](#)
[C4532NP01H154J250KA](#) [CD75-B2GA331KYGKA](#) [CLF10040T-221M](#) [CLF12555T-220M](#) [R22095*REPAIRED](#) [MLF1005LR12K](#)
[VLS252015T-3R3M1R0](#) [VLS4012T-150MR65](#) [ZCAT-KIT](#) [MPZ2012-KIT](#) [NLV32T-R27J-EFD](#) [CGA3EANP02A682J080AC](#)
[CKCM25C0G2A101K060AK](#) [CLF10040T-4R7N](#) [WTM505090-10K2-5V-G1](#) [VLS252010HBX-R24M-1](#) [CGJ2B2X7R1C222K](#)
[CGA9M1X7T2J334K](#) [CGA8P3X7T2E105M/SOFT](#) [CGA6J4C0G2J392J](#) [CGA6M3X7R2E154K](#) [CGA3E3C0G2E181J](#) [CGA2B2C0G1H331J](#)
[C-WPTX01-E6-KIT](#) [CEU-AC01-E6-KIT](#) [CERB3UX5R0G105M](#) [RLF12545T-100M5R1-PF](#) [PFE500F28/T](#) [CCT406393-600-36-02](#)
[PFC3819QM-181K09B-00](#) [VLF3010AT-100MR49](#) [MMZ0603D330C](#) [MPZ2012S102ATD25](#) [MLG0603P-2-KIT](#) [MLG1608B18NJ](#) [UHV-251A](#) [FHV-11AN](#)