

SPECIFICATION

SPEC. No. U227NAA00380

DATE: July 5, 2016

To

XIANGGAO/MIDEA

CUSTOMER'S PRODUCT NAME

TDK'S PRODUCT NAME

MLG0603W series

RECEIPT CONFIRMATION

DATE: YEAR MONTH DAY

TDK Corporation

Sales

Electronic Components
Sales & Marketing Group

Engineering

Electronic Components Business Company
Magnetics Business Group
Multilayer Products Business Unit

APPROVED	PERSON IN CHARGE

APPROVED	CHECKED	PERSON IN CHARGE
Y.Abe	K.Sasaki	S.Abe

TDK Confidential

CAUTION WHEN HANDLING

Before use the products, please read this specification.

CAUTION FOR SAFETY USING

When use the products, be careful to the mentioned below for safety using.



CAUTION

- * Do not use and store the product in condition of gas corrosion (Salt, Acid, Alkaline).
- * The product must be preheated before soldering. Difference between preheat and soldering temperature must be within 150°C.
- * Rework by soldering iron ; Please keep the mentioned conditions in this specification.
- * When the product is coated with resin, please verify the quality influence on the product.
- * Please verify carefully that there is no harmful decomposing or reaction gas emission from resin during curing process or under natural condition, which may generate an adverse impact on the product.
- * In case of insert P.C. Board on chassis, do not add mechanical stress to the product.
- * The product has self heat (temperature rise) by current, so keep margin for heat design.
- * Please pay attention to arrangement of non-magnetic type inductors in board design. Errors may be caused by magnetic field coupling.
- * To handle the products, please use wrist strap for ground static discharge on human body.
- * Please keep the product away from magnet or magnetized things.
- * Do not use the product beyond the mentioned conditions in this specification.
- * About an application

The products listed on this specification sheet are intended for use in general electronic equipment (AV equipment, telecommunications equipment, home appliances, amusement equipment, computer equipment, personal equipment, office equipment, measurement equipment, industrial robots) under a normal operation and use condition. The products are not designed or warranted to meet the requirements of the applications listed below, whose performance and/or quality require a more stringent level of safety or reliability, or whose failure, malfunction or trouble could cause serious damage to society, person or property. Please understand that we are not responsible for any damage or liability caused by use of the products in any of the applications below or for any other use exceeding the range or conditions set forth in this specification sheet.

- 1) Aerospace/Aviation equipment
- 2) Medical equipment which directly endanger human life
- 3) Power-generation control equipment
- 4) Atomic energy-related equipment
- 5) Seabed equipment
- 6) Transportation control equipment
- 7) Military equipment
- 8) Safety equipment
- 9) Other applications that are not considered general-purpose applications

If you intend to use the products in the following applications, please contact our sales office.

- + Transportation equipment (cars, electric trains, ships, etc.),
- + Public information-processing equipment,
- + Electric heating apparatus / burning equipment,
- + Disaster prevention/crime prevention equipment

When using this product in general-purpose applications, you are kindly requested to take into consideration securing protection circuit/equipment or providing backup circuits, etc., to ensure higher safety.

1. SCOPE

This specification applies to the MULTILAYER CERAMIC COIL (MLG0603W series).
It is delivered to XIANGGAO/MIDEA.

2. PRODUCT NAME

Product name decided in this specification is due to Table3 on page3 to 6.

3. CONTENT MENTIONED

Item	Attached drawings and tables	Page
1. OUTLINE DRAWING AND DIMENSION	Table 1 to Table 2, Figure 1	2
2. ELECTRICAL CHARACTERISTICS	Table 3	3 to 6
3. RELIABILITY SPECIFICATION	Table 4	7 to 8
4. MEASUREMENT METHOD	—————	9
5. RELIABILITY TEST	Table 5, Figure 2 to Figure 4	10 to 11
6. PACKAGING	Table 6 to Table 7 Figure 5 to Figure 9	12 to 14
7. OTHERS	Figure 10 to Figure 11	15 to 16

Measurement condition:

Unless otherwise specified, the standard measurement conditions are as follow;

Ambient temperature : 5°C to 35°C
Relative humidity : 35 % to 85 %
Air pressure : 86 to 106kPa

If there is any doubt about the results, measurements shall be made within the following conditions;

Ambient temperature : 20 ± 2°C
Relative humidity : 60 % to 70 %
Air pressure : 86 to 106kPa

Revision Records

Rev.	Date	Revised By	Change Description
			Initial Date
			Spec. No.
			July 5, 2016
			U227NAA00380

1-1) Outline drawing and Dimension

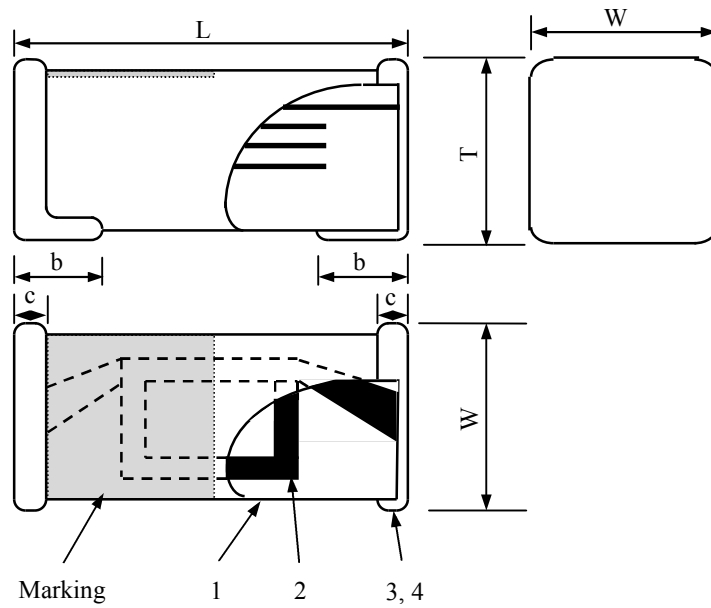

[Figure 1]

*) Take care of direction of marking to prevent inductance unevenness.
 (There is no polarity, however unevenness of inductance could occur)

[Table 1]

Dimension and Tolerance (mm)				
L	W	T	b	c
0.60±0.03	0.30±0.03	0.30±0.03	0.15±0.05	0.09±0.04

1-2) Making of material

[Table 2]

No.	Item	Material
1	Core	Dielectric ceramics
2	Internal electrode	Ag
3	Terminal electrode (Inside)	Ag
4	Terminal electrode (Outside)	Electro plating (Ni-Sn)

[Table 3]

Customer's Product Name	TDK's Product Name	Inductance L[nH] and Tolerance		L,Q test freq. [MHz]	Q Min.	S.R.F. [GHz] Min.	R.D.C. [ohm] Max.	I.D.C. [mA] Max.
	MLG0603W0N2BT***	*1)	B:±0.1nH C:±0.2nH	100	-	10.0	0.06	1000
	MLG0603W0N2CT***	0.20						
	MLG0603W0N3BT***	0.30						
	MLG0603W0N3CT***							
	MLG0603W0N4BT***	0.40						
	MLG0603W0N4CT***							
	MLG0603W0N5BT***	0.50						
	MLG0603W0N5CT***							
	MLG0603W0N6BT***	0.60						
	MLG0603W0N6CT***							
	MLG0603W0N7BT***	0.70						
	MLG0603W0N7CT***							
	MLG0603W0N8BT***	0.80						
	MLG0603W0N8CT***							
	MLG0603W0N9BT***	0.90						
	MLG0603W0N9CT***							
	MLG0603W1N0BT***	1.00	B:±0.1nH C:±0.2nH S:±0.3nH		5	10.0	0.09	800
	MLG0603W1N0CT***							
	MLG0603W1N0ST***							
	MLG0603W1N1BT***	1.10						
	MLG0603W1N1CT***							
	MLG0603W1N1ST***							
	MLG0603W1N2BT***	1.20						
	MLG0603W1N2CT***							
	MLG0603W1N2ST***							
	MLG0603W1N3BT***	1.30						
	MLG0603W1N3CT***							
	MLG0603W1N3ST***							
	MLG0603W1N4BT***	1.40						
	MLG0603W1N4CT***							
	MLG0603W1N4ST***							
	MLG0603W1N5BT***	1.50						
	MLG0603W1N5CT***							
	MLG0603W1N5ST***							
	MLG0603W1N6BT***	1.60						
	MLG0603W1N6CT***							
	MLG0603W1N6ST***							
	MLG0603W1N7BT***	1.70						
	MLG0603W1N7CT***							
	MLG0603W1N7ST***							
	MLG0603W1N8BT***	1.80						
	MLG0603W1N8CT***							
	MLG0603W1N8ST***							
	MLG0603W1N9BT***	1.90						
	MLG0603W1N9CT***							
	MLG0603W1N9ST***							
	MLG0603W2N0BT***	2.00						
	MLG0603W2N0CT***							
	MLG0603W2N0ST***							
	MLG0603W2N1BT***	2.10						
	MLG0603W2N1CT***							
	MLG0603W2N1ST***							

*1) 0N2C tolerance is -0.1nH/+0.2nH

[Table 3]

Customer's Product Name	TDK's Product Name	Inductance L[nH] and Tolerance	L,Q test freq. [MHz]	Q Min.	S.R.F. [GHz] Min.	R.D.C. [ohm] Max.	I.D.C. [mA] Max.
	MLG0603W2N2BT***	2.20	B:±0.1nH C:±0.2nH S:±0.3nH	100	5	0.20	500
	MLG0603W2N2CT***						
	MLG0603W2N2ST***	2.30					
	MLG0603W2N3BT***						
	MLG0603W2N3CT***	2.40					
	MLG0603W2N3ST***						
	MLG0603W2N4BT***	2.50					
	MLG0603W2N4CT***						
	MLG0603W2N4ST***	2.60					
	MLG0603W2N5BT***						
	MLG0603W2N5CT***	2.70					
	MLG0603W2N5ST***						
	MLG0603W2N6BT***	2.80					
	MLG0603W2N6CT***						
	MLG0603W2N6ST***	2.90					
	MLG0603W2N7BT***						
	MLG0603W2N7CT***	3.00					
	MLG0603W2N7ST***						
	MLG0603W2N8BT***	3.10					
	MLG0603W2N8CT***						
	MLG0603W2N8ST***	3.20					
	MLG0603W2N9BT***						
	MLG0603W2N9CT***	3.30					
	MLG0603W2N9ST***						
	MLG0603W3N0BT***	3.40					
	MLG0603W3N0CT***						
	MLG0603W3N0ST***	3.50					
	MLG0603W3N1BT***						
	MLG0603W3N1CT***	3.60					
	MLG0603W3N1ST***						
	MLG0603W3N2BT***	3.70					
	MLG0603W3N2CT***						
	MLG0603W3N2ST***	3.80					
	MLG0603W3N3BT***						
	MLG0603W3N3CT***	3.90					
	MLG0603W3N3ST***						
	MLG0603W3N4BT***	3.90					
	MLG0603W3N4CT***						
	MLG0603W3N4ST***	3.90					
	MLG0603W3N5BT***						
	MLG0603W3N5CT***	3.90					
	MLG0603W3N5ST***						
	MLG0603W3N6BT***	3.90					
	MLG0603W3N6CT***						
	MLG0603W3N6ST***	3.90					
	MLG0603W3N7BT***						
	MLG0603W3N7CT***	3.90					
	MLG0603W3N7ST***						
	MLG0603W3N8BT***	3.90					
	MLG0603W3N8CT***						
	MLG0603W3N8ST***	3.90					
	MLG0603W3N9BT***						
	MLG0603W3N9CT***	3.90					
	MLG0603W3N9ST***						

[Table 3]

Customer's Product Name	TDK's Product Name	Inductance L[nH] and Tolerance		L,Q test freq. [MHz]	Q Min.	S.R.F. [GHz] Min.	R.D.C. [ohm] Max.	I.D.C. [mA] Max.								
	MLG0603W4N0BT***	4.00	B:±0.1nH C:±0.2nH S:±0.3nH	100	5	5.8	0.40	350								
	MLG0603W4N0CT***															
	MLG0603W4N0ST***															
	MLG0603W4N1BT***	4.10	S:±0.3nH H:±3% J:±5%			5.8	0.40	350								
	MLG0603W4N1CT***															
	MLG0603W4N1ST***	4.30				S:±0.3nH H:±3% J:±5%	5.5	0.40	350							
	MLG0603W4N3HT***															
	MLG0603W4N3JT***															
	MLG0603W4N5ST***	4.50					S:±0.3nH H:±3% J:±5%	5.5	0.40	350						
	MLG0603W4N5HT***															
	MLG0603W4N5JT***	4.70						S:±0.3nH H:±3% J:±5%	5.5	0.40	350					
	MLG0603W4N7ST***															
	MLG0603W4N7HT***	4.90							S:±0.3nH H:±3% J:±5%	5.5	0.40	350				
	MLG0603W4N7JT***															
	MLG0603W4N9ST***	5.10								S:±0.3nH H:±3% J:±5%	4.0	0.40	350			
	MLG0603W4N9HT***															
	MLG0603W4N9JT***															
	MLG0603W5N1ST***	5.40									S:±0.3nH H:±3% J:±5%	4.0	0.40	350		
	MLG0603W5N1HT***															
	MLG0603W5N1JT***	5.60										S:±0.3nH H:±3% J:±5%	4.0	0.70	300	
	MLG0603W5N4ST***															
	MLG0603W5N4HT***															
	MLG0603W5N4JT***	6.00											S:±0.3nH H:±3% J:±5%	4.0	0.70	300
	MLG0603W5N6ST***															
	MLG0603W5N6HT***	6.20		S:±0.3nH H:±3% J:±5%	4.0									0.75	300	
	MLG0603W5N6JT***															
	MLG0603W6N0ST***	6.60			S:±0.3nH H:±3% J:±5%									4.0	0.75	300
	MLG0603W6N0HT***															
	MLG0603W6N0JT***															
	MLG0603W6N2ST***	6.80	S:±0.3nH H:±3% J:±5%			4.0								0.80	300	
	MLG0603W6N2HT***															
	MLG0603W6N2JT***	7.30				S:±0.3nH H:±3% J:±5%								4.0	0.80	300
	MLG0603W6N6HT***															
	MLG0603W6N6JT***															
	MLG0603W6N8HT***	7.50					S:±0.3nH H:±3% J:±5%	4.0						0.85	250	
	MLG0603W6N8JT***															
	MLG0603W7N3HT***	8.00						S:±0.3nH H:±3% J:±5%	4.0					0.85	250	
	MLG0603W7N3JT***															
	MLG0603W7N5HT***	8.20							S:±0.3nH H:±3% J:±5%	4.0				0.90	250	
	MLG0603W7N5JT***															
	MLG0603W8N0HT***															
	MLG0603W8N0JT***	8.90								S:±0.3nH H:±3% J:±5%	4.0			0.90	250	
	MLG0603W8N2HT***															
	MLG0603W8N2JT***	9.10									S:±0.3nH H:±3% J:±5%	4.0		0.95	250	
	MLG0603W8N9HT***															
	MLG0603W8N9JT***															
	MLG0603W9N1HT***	10.0										S:±0.3nH H:±3% J:±5%	4.0	0.95	250	
	MLG0603W9N1JT***															
	MLG0603W10NHT***	11.0		S:±0.3nH H:±3% J:±5%									6	3.5	1.00	250
	MLG0603W10NJT***															
	MLG0603W11NHT***															
	MLG0603W11NJT***															

[Table 3]

Customer's Product Name	TDK's Product Name	Inductance L[nH] and Tolerance	L,Q test freq. [MHz]	Q Min.	S.R.F. [GHz] Min.	R.D.C. [ohm] Max.	I.D.C. [mA] Max.	
	MLG0603W12NHT***	12.0	H:±3% J:±5%	100	6	3.5	1.10	250
	MLG0603W12NJT***							
	MLG0603W13NHT***	13.0				1.10	250	
	MLG0603W13NJT***							
	MLG0603W15NHT***	15.0				1.20	250	
	MLG0603W15NJT***							
	MLG0603W16NHT***	16.0				1.20	200	
	MLG0603W16NJT***							
	MLG0603W18NHT***	18.0				1.40	200	
	MLG0603W18NJT***							
	MLG0603W20NHT***	20.0				1.90	150	
	MLG0603W20NJT***							
	MLG0603W22NHT***	22.0				1.90	150	
	MLG0603W22NJT***							
	MLG0603W24NHT***	24.0				2.10	140	
	MLG0603W24NJT***							
	MLG0603W27NHT***	27.0				2.10	140	
	MLG0603W27NJT***							
	MLG0603W30NHT***	30.0				2.20	130	
	MLG0603W30NJT***							
	MLG0603W33NHT***	33.0				2.20	130	
	MLG0603W33NJT***							
	MLG0603W36NHT***	36.0				2.40	120	
	MLG0603W36NJT***							
	MLG0603W39NHT***	39.0	2.40	120				
	MLG0603W39NJT***							
	MLG0603W43NHT***	43.0	2.90	110				
	MLG0603W43NJT***							
	MLG0603W47NHT***	47.0	2.90	110				
	MLG0603W47NJT***							
	MLG0603W51NHT***	51.0	3.50	100				
	MLG0603W51NJT***							
	MLG0603W56NHT***	56.0	3.50	100				
	MLG0603W56NJT***							
	MLG0603W62NHT***	62.0	3.50	100				
	MLG0603W62NJT***							
	MLG0603W68NHT***	68.0	3.50	100				
	MLG0603W68NJT***							
	MLG0603W75NHT***	75.0	4.00	80				
	MLG0603W75NJT***							
	MLG0603W82NHT***	82.0	4.00	80				
	MLG0603W82NJT***							
	MLG0603W91NHT***	91.0	4.50	80				
	MLG0603W91NJT***							
	MLG0603WR10HT***	100	4.50	80				
	MLG0603WR10JT***							
	MLG0603WR11HT***	110	5.00	80				
	MLG0603WR11JT***							
	MLG0603WR12HT***	120	5.00	80				
	MLG0603WR12JT***							

[Table 4]

TDK's Product Name	Reliability Spec.		L,Q Test freq. [MHz]
	Inductance L[nH]	Q	
MLG0603W0N2	-	-	100
MLG0603W0N3			
MLG0603W0N4			
MLG0603W0N5			
MLG0603W0N6			
MLG0603W0N7			
MLG0603W0N8			
MLG0603W0N9			
MLG0603W1N0			
MLG0603W1N1			
MLG0603W1N2			
MLG0603W1N3			
MLG0603W1N4			
MLG0603W1N5			
MLG0603W1N6			
MLG0603W1N7			
MLG0603W1N8			
MLG0603W1N9			
MLG0603W2N0			
MLG0603W2N1			
MLG0603W2N2			
MLG0603W2N3			
MLG0603W2N4			
MLG0603W2N5			
MLG0603W2N6			
MLG0603W2N7			
MLG0603W2N8			
MLG0603W2N9			
MLG0603W3N0			
MLG0603W3N1			
MLG0603W3N2			
MLG0603W3N3			
MLG0603W3N4			
MLG0603W3N5			
MLG0603W3N6			
MLG0603W3N7			
MLG0603W3N8			
MLG0603W3N9			
MLG0603W4N0			
MLG0603W4N1			
MLG0603W4N3			
MLG0603W4N5			
MLG0603W4N7			
MLG0603W4N9			
MLG0603W5N1			
MLG0603W5N4			
MLG0603W5N6			
MLG0603W6N0			
MLG0603W6N2			

[Table 4]

TDK's Product Name	Reliability Spec.		L,Q Test freq. [MHz]
	Inductance L[nH]	Q	
MLG0603W6N6	Initial Value±5%	Initial Value±30%	100
MLG0603W6N8			
MLG0603W7N3			
MLG0603W7N5			
MLG0603W8N0			
MLG0603W8N2			
MLG0603W8N9			
MLG0603W9N1			
MLG0603W10N			
MLG0603W11N			
MLG0603W12N			
MLG0603W13N			
MLG0603W15N			
MLG0603W16N			
MLG0603W18N			
MLG0603W20N			
MLG0603W22N			
MLG0603W24N			
MLG0603W27N			
MLG0603W30N			
MLG0603W33N			
MLG0603W36N			
MLG0603W39N			
MLG0603W43N			
MLG0603W47N			
MLG0603W51N			
MLG0603W56N			
MLG0603W62N			
MLG0603W68N			
MLG0603W75N			
MLG0603W82N			
MLG0603W91N			
MLG0603WR10			
MLG0603WR11			
MLG0603WR12			

4-1) Inductance and Q values

4-1-1) Test equipment and test fixture

Test equipment: IMPEDANCE ANALYZER 4291A HP (or equivalent)

Test fixture: 16197A Agilent (or equivalent) *Residual inductance of short bar = 0nH

4-1-2) Test method

Set the chip on test fixture. Test frequency is due to Table 3.

4-2) Direct Current Resistance (R.D.C.)

4-2-1) Test equipment

Test equipment: DIGITAL MILLIOHM METER Type7561 YOKOGAWA

(or equivalent)

4-3) Self Resonance Frequency (S.R.F.)

4-3-1) Test equipment

Test equipment: 8720C HP (or equivalent)

4-3-2) Test method

Self resonance frequency is “Frequency that phase becomes 0 degree”

that means switching frequency between inductive reactance and capacitive

reactance when measure attenuation with transmission characteristic measurement.

4-4) RATED CURRENT

4-4-1) Temperature Rise

Rated current is the current which causes a temperature rise within 20°C.

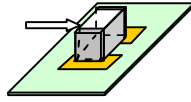
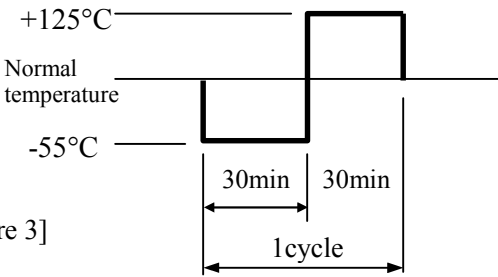
[Table 5]			
No.	Item	Specification	Test method
5-1	Adhesive test	2N min.	<p>Add the force to solder specimen inductor on the test printed circuit board.</p> <p style="text-align: center;">Pressure </p> <p style="text-align: center;">[Figure 2]</p>
5-2	Vibration test	Appearance : No mechanical damage. To satisfy reliability spec.(Table 4)	<p>Solder specimen inductor on the test printed circuit board. Apply vibrations in each of the x, y and z directions for 2 hours (total of 6 hours). REF : JIS-C-0040</p> <p style="text-align: center;">Frequency : 10 - 500 - 10Hz Total amplitude: 1.5mm</p>
5-3	Shock test	Appearance : No mechanical damage. To satisfy reliability spec.(Table 4)	<p>Solder specimen inductor on the test printed circuit board.</p> <p>Acceleration 1000m/s^2, action time 6ms, half wave sine 6×3.</p>
5-4	Cold test	Appearance : No mechanical damage. To satisfy reliability spec.(Table 4)	<p>Solder specimen inductor on the test printed circuit board, then leave it at temperature for $-55\pm 2^\circ\text{C}$ for 500 ± 12 hours.</p> <p>Measure the test items after leaving the inductors at room temperature and humidity for 1 to 2 hours.</p>
5-5	Heat shock test	Appearance : No mechanical damage. To satisfy reliability spec.(Table 4)	<p>Solder specimen inductor on the test printed circuit board, then go through 100 cycles under the following conditions.</p> <p style="text-align: center;">  </p> <p style="text-align: center;">[Figure 3]</p> <p>Measure the test items after leaving the inductors at room temperature and humidity for 1 to 2 hours.</p>

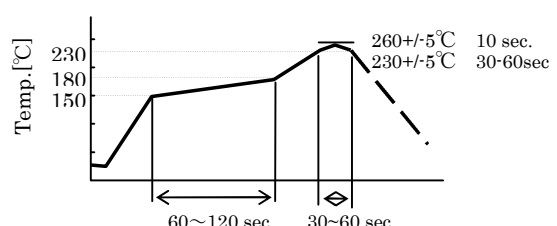
[Table 5]			
No.	Item	Specification	Test method
5-6	Humidity with load test	Appearance : No mechanical damage. To satisfy reliability spec.(Table 4)	Solder specimen inductor on the test printed circuit board, then leave it at temperature for $60\pm 2^{\circ}\text{C}$ for 500 ± 12 hours, and relative humidity of 90% to 95% with the rated electric current applied. Measure the test items after leaving the inductors at room temperature and humidity for 1 to 2 hours.
5-7	High temperature with load test	Appearance : No mechanical damage. To satisfy reliability spec.(Table 4)	Solder specimen inductor on the test printed circuit board, then leave it at temperature for $125\pm 2^{\circ}\text{C}$ for 500 ± 12 hours with the rated electric current applied. Measure the test items after leaving the inductors at room temperature and humidity for 1 to 2 hours.
5-8	Resistance to soldering heat test	Appearance : No mechanical damage.	Solder specimen inductor on the test printed circuit board, then pass it 2 times under conditions. Measure the test items after leaving the inductors at room temperature and humidity for 1 to 2 hours. Solder : Sn-3Ag-0.5Cu.  [Figure4]
5-9	Solderability test	Terminal electrodes should be covered by new solder to a minimum of 95%	Apply flux application and preheat for 1 to 2 minutes at 150°C to 180°C , then dip in solder at $250\sim 260^{\circ}\text{C}$ for 4.0 ± 0.5 seconds. Flux: Rosin (JIS-K-5902) dissolved in Isopropyl alcohol (JIS-K-8839) at 25 wt %. Solder: Sn-3Ag-0.5Cu.

6-1) Reel dimension

*) Shaded portion is hole

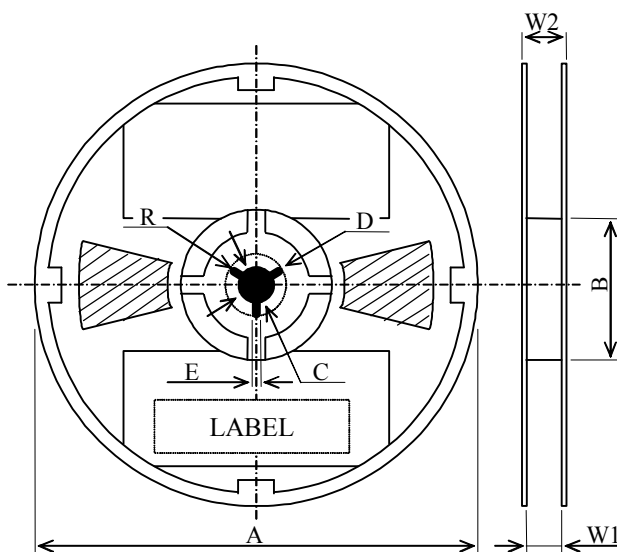

Material of reel: Polystyrene

[Figure 5]

[Table 6]

(Unit: mm)

Mark	A	B	C	D	E
Dimension	$\Phi 180.0 \pm 2.0$	$\Phi 60.0$ Min.	$\Phi 13.0 \pm 0.2$	$\Phi 21.0 \pm 0.8$	2.0 ± 0.5
Mark	W1	W2	R		
Dimension	$8.4 + 2.0/0$	14.4 Max.	1.0		

6-2) Marking

The marking shall be seen from the top cover tape side.

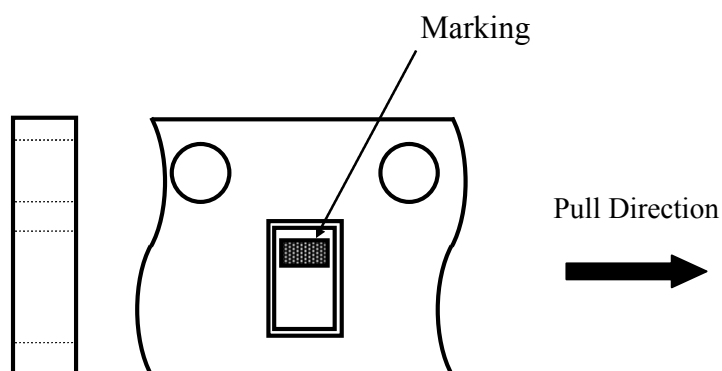

[Figure 6]

6-3) Tape dimension

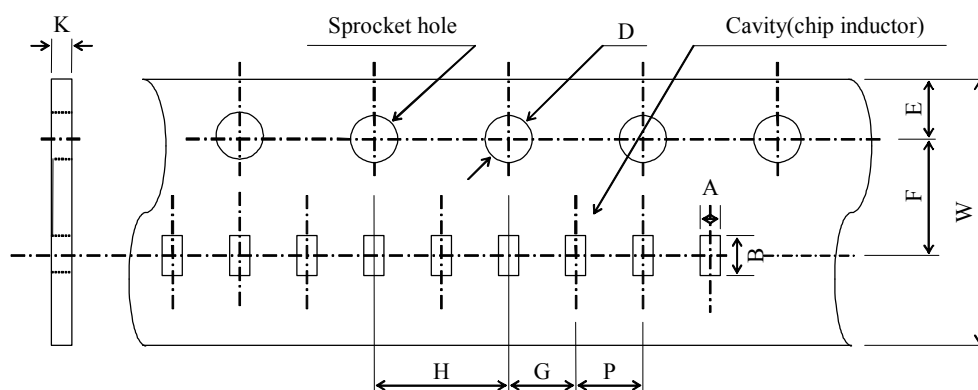

Material of carrier tape : paper
 Material of cover tape : polyester

[Figure 7]

[Table 7] (unit: mm)

Mark	A	B	D	E	F
Dimension	0.38±0.05	0.68±0.05	Φ1.50+0.10/0	1.75±0.10	3.50±0.05
Mark	G	H	K	P	W
Dimension	2.00±0.05	4.00±0.10	0.50 MAX	2.00±0.05	8.00±0.30

6-4) Shape of packing

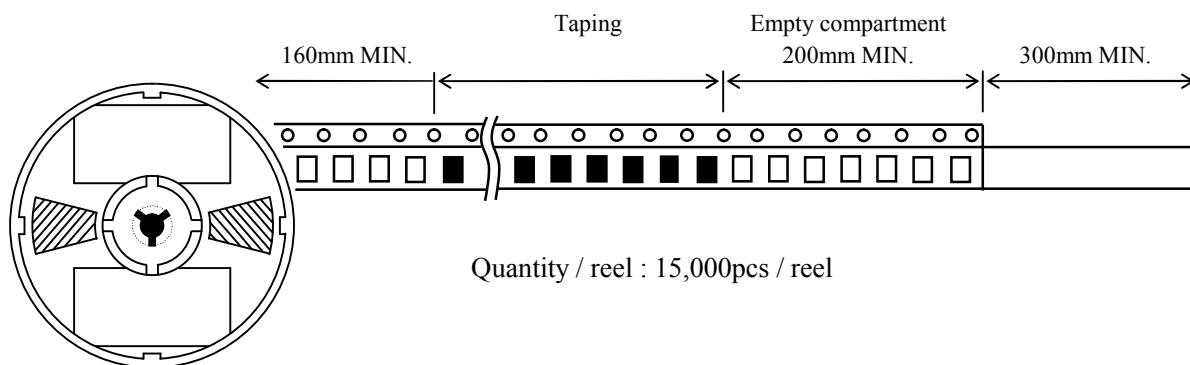

Quantity / reel : 15,000pcs / reel

[Figure 8]

6-5) Packing form and indication contents

(For example)

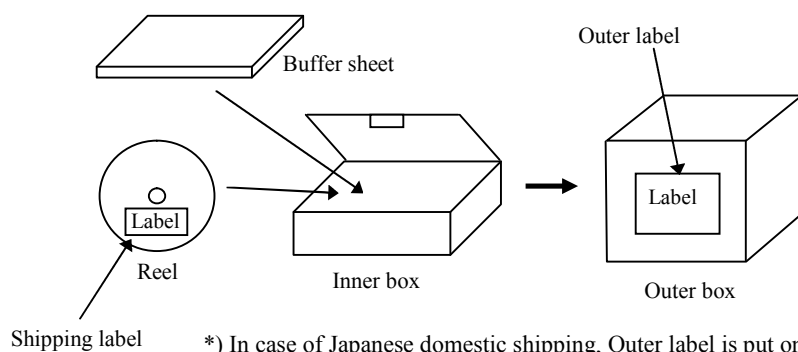

Indication contents of a label

1. ITEM CODE
2. Shipping No
3. ITEM
4. SHIPING DATE
5. QTY.
6. Origin country
7. Customer's Product Name

*) In case of Japanese domestic shipping, Outer label is put on the Inner box.
Because Outer box isn't used.

[Figure 9]

6-6) Peel back force

Peel back force is 0.1N to 1.0N in accordance with JIS C 0806.

6-7) Storage conditions

After delivered, use the products within 12 months under the conditions 5 to 40 °C and 10 to 75%RH.
Solderability should be confirmed in case of exceeding 12 months

7-1) Operating / Storage temperature range
-55 to +125°C

7-2) Humidity range
0 to 90%RH (The least upper wet-bulb temperature is 38°C)

7-3) Product identification

<u>MLG</u>	<u>0603</u>	<u>W</u>	<u>27N</u>	<u>J</u>	<u>#</u>	<u>***</u>
(1)	(2)	(3)	(4)	(5)	(6)	(7)

- (1) Product symbol
- (2) Dimensions (0.6×0.3mm)
- (3) Series name
- (4) Inductance (27N: 27nH)
- (5) Inductance Tolerance (B: ±0.1nH, C: ±0.2nH, S: ±0.3nH, G: ±2%, H: ±3%, J: ±5%)
- (6) Packing style (T: taping)
- (7) Control number

7-4) Precautions

7-4-1) Recommended reflow soldering conditions.

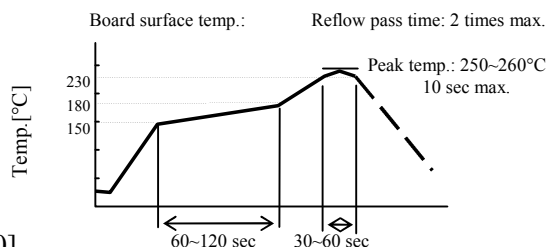

[Figure 10]

7-4-2) Reworking condition

By using spot heater, in a temperature 350 °C max, more than a distance 3mm from the product within 5 seconds.

7-4-3) Recommended land pattern

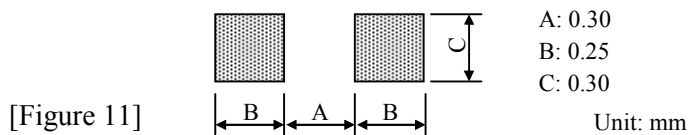

[Figure 11]

7-4-4) Recommended cleaning conditions after soldering.

Recommended rinse agent is IPA (Isopropyl alcohol).

If use other agent, confirm soldering conditions in person.

Ultrasonic cleaning shall be in the normal temperature 20W/1 max., 28kHz ~ 40kHz, 5 minute max.

- 7-5) This product contains no lead and also support lead-free soldering.
- 7-6) This product corresponds to ROHS.
It contains neither Cd, Pb, Hg, Cr6+, PBB nor PBDE.
- 7-7) MSL
MSL is in accordance with Level-1
- 7-8) Halogen-free
This product corresponds to Halogen-free as below.
Cl content is less than 900ppm
Br content is less than 900ppm
Total Cl and Br content is less than 1,500ppm
- 7-9) Origin country
Japan
China
- 7-10) Appearance
(1)Applied standard/Sampling inspection
JIS Z 9015
Single normal sampling / LV-II
(2)Shipment standard
Major defect (*1) : AQL 0.1
Minor defect (*2) : AQL 0.4
*1:Its appearance condition makes an effect on electrical characteristics that we assure.
*2:Its appearance condition does not make an effect on electrical characteristics that we assure.

X-ON Electronics

Largest Supplier of Electrical and Electronic Components

Click to view similar products for [Fixed Inductors](#) category:

Click to view products by [TDK](#) manufacturer:

Other Similar products are found below :

[MLZ1608M6R8WTD25](#) [MLZ1608N6R8LT000](#) [MLZ1608N3R3LTD25](#) [MLZ1608N3R3LT000](#) [MLZ1608N150LT000](#)

[MLZ1608M150WTD25](#) [MLZ1608M3R3WTD25](#) [MLZ1608M3R3WT000](#) [MLZ1608M150WT000](#) [MLZ1608A1R5WT000](#)

[MLZ1608N1R5LT000](#) [B82432C1333K000](#) [PCMB053T-1R0MS](#) [PCMB053T-1R5MS](#) [PCMB104T-1R5MS](#) [CR32NP-100KC](#) [CR32NP-](#)

[151KC](#) [CR32NP-180KC](#) [CR32NP-181KC](#) [CR32NP-1R5MC](#) [CR32NP-390KC](#) [CR32NP-3R9MC](#) [CR32NP-680KC](#) [CR32NP-820KC](#)

[CR32NP-8R2MC](#) [CR43NP-390KC](#) [CR43NP-560KC](#) [CR43NP-680KC](#) [CR54NP-181KC](#) [CR54NP-470LC](#) [CR54NP-820KC](#) [CR54NP-8R5MC](#)

[MGDQ4-00004-P](#) [MGDU1-00016-P](#) [MHL1ECTTP18NJ](#) [MHL1JCTTD12NJ](#) [PE-51506NL](#) [PE-53601NL](#) [PE-53630NL](#) [PE-53824SNLT](#) [PE-](#)

[62892NL](#) [PE-92100NL](#) [PG0434.801NLT](#) [PG0936.113NLT](#) [PM06-2N7](#) [PM06-39NJ](#) [HC2LP-R47-R](#) [HC2-R47-R](#) [HC3-2R2-R](#) [HC8-1R2-R](#)