

SPECIFICATION

SPEC. No. C519NAA00003

DATE June. 12. 2018

To

Xiaomi

CUSTOMER'S PRODUCT NAME

TDK'S PRODUCT NAME

THIN FILM INDUCTOR
TFM201208ALD-TCA Series

RECEIPT CONFIRMATION

DATE: _____ YEAR _____ MONTH _____ DAY _____

TDK Corporation
Sales
Electronic Components Sales &
Marketing Group

Engineering
TDK Corporation
Magnetics Business Group

APPROVED	Person in charge

APPROVED	CHECKED	Person in charge
<i>H. P. Khulbe</i>	<i>M. Orata</i>	<i>Z. Eda</i>

Scope

This specifications applies to THIN FILM INDUCTOR
TFM201208ALD-TCA Series to be delivered to Xiaomi.

Product identification

TFM 2012 08 ALD - R47 M T CA
(1) (2) (3) (4) (5) (6) (7) (8)

- | | |
|---|---------------------------------|
| (1) Part Number | (5) Inductance value |
| (2) Product dimensions (Length x Width) | (6) Inductance tolerance |
| (3) Product height | (7) Packaging style designation |
| (4) Product identification number | (8) Control mark |

Mentioned item

1. Shapes and dimension and an equivalent circuit
2. Electrical characteristics
3. Storage temperature range
4. Operating temperature range
5. Structure and used material
6. Reliability test
7. Recommended footprint
8. Recommended reflow pattern
9. Packaging
10. Attention in case of using
11. Packaging form

Others

In case any matter other than stated in this specification should take place,
it shall be decided upon on a case by case basis.

Please return a copy of this specification document with your signature to us within 2 months
after this document is issued.

If a copy of this document with your signature is not received within the above mentioned period
after its issue date, the product specification will be deemed to have been accepted by you.

Change history

No.	DATE	DRAWN	CHANGE ITEM
MAGNETICS BUSINESS GROUP TDK Corporation			DATE ISSUED June. 12. 2018
			REF. No. C519NAA00003
			PAGE. 1 / 7

1. Shapes and dimension and an equivalent circuit

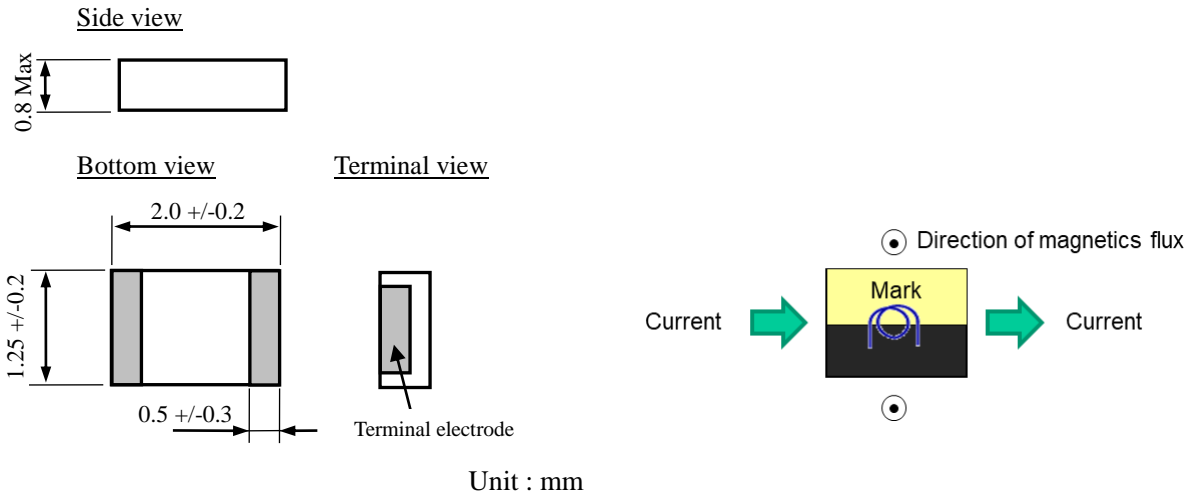

2. Electrical characteristics

2-1. Electrical spec. (Tentative SPEC)

Part No.	TDK Item name	Inductance [μ H] @ 1MHz	Rdc [m Ω]		Isat [A]		Itemp [A]	
			Max	Typ	Max	Typ	Max	Typ
	TFM201208ALD-R47MTCA	0.47 \pm 20%	28	26	4.5	5.0	4.1	4.3

Isat : Current flows and the initial value of inductance has fallen by 30%

Itemp : Current flows and the temperature has risen to 40°C

Rated Current: The less value which is Isat Max or Itemp Max.

Rated Voltage of these items: 20V Max.

2-2. Test Equipment

Inductance : Agilent 4294A Impedance analyzer or suitable. (OSC=0.5V / Frequency=1MHz)

Rdc : Digital Milliohm Meter

2-3. Measuring condition

Unless otherwise specified, measurement should be performed at 5 to 35°C and 35 to 85%RH.

However, for referee purpose at 25+/-5 °C and 40 to 70%RH.

2-4. MSL

MSL Level 1

3. Storage temperature range

3-1. Condition for storage before mounting.

Store this product under the condition of 5 to 40°C ,20 to 75%RH and use within 6 months from the delivery date.

3-2. Condition for storage after mounting.

-40°C to +85°C

4. Operating temperature range

-40°C to +85°C

Self temperature rise : 40°C max. (Room temperature measure)

It's less than 125 degrees, and please use product temperature by ambient temperature + self temperature-rise.

5. Product structure and used material

Appearance

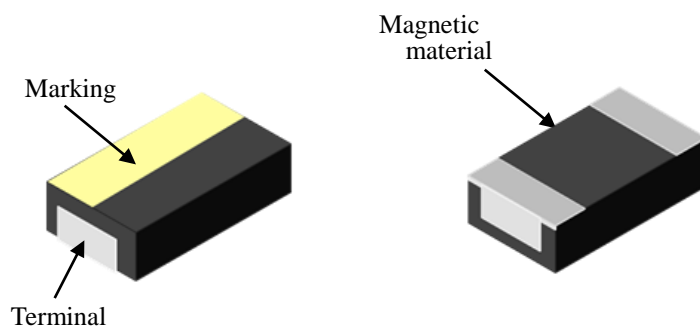

Item	Material
Magnetic material	Metal alloy
Terminal	Base : Conductive resin Plating : Ni-Sn
Marking	TiO ₂

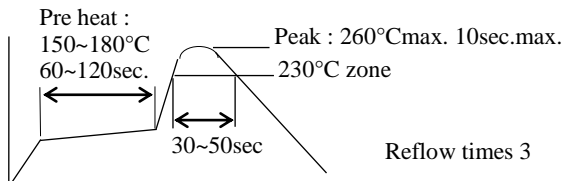
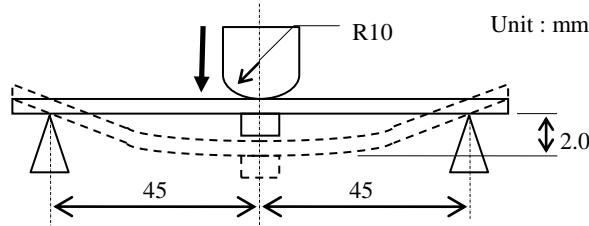
6. Reliability test		
Item	Specifications	Test conditions
Solder ability	The terminal electrodes should be covered by new solder over than 95%.	Apply cream solder to the printed PC board. Refer to clause 8 for Reflow profile.
Soldering heat resistance	Inductance variation to be within $\pm 10\%$ of the initial value. There shall be no mechanical damages.	Reflow of the following profile is performed four times. 
Strength on PCB board bending	There shall be no mechanical damages.	After the samples shall be soldered on PCB, the test shall be done. Apply the load in direction of the arrow until the bending reaches 2.0mm. (PCB thickness = 1.6mm) 
High temperature resistance with load	Inductance variation to be within $\pm 10\%$ of the initial value. There shall be no mechanical damages.	After the samples shall be soldered on PCB, the test shall be done. Temperature : $85 \pm 2^\circ\text{C}$ Applied bias : Rated current Testing time : 500 ± 12 hours
Humidity resistance with load	Inductance variation to be within $\pm 10\%$ of the initial value. There shall be no mechanical damages.	After the samples shall be soldered on PCB, the test shall be done. Temperature : $60 \pm 2^\circ\text{C}$, Humidity : 90~95%RH Applied bias : Rated current : 1hr. on / 3hr. off Testing time : 500 ± 12 hours
Thermal shock	Inductance variation to be within $\pm 10\%$ of the initial value. There shall be no mechanical damages.	After the samples shall be soldered on PCB, the test shall be done. Temperature : $-40 \pm 2^\circ\text{C} / +85 \pm 2^\circ\text{C}$ Stable time : 30min for each temperature. Test cycle : 100 Cycle
Low temperature storage	Inductance variation to be within $\pm 10\%$ of the initial value. There shall be no mechanical damages.	After the samples shall be soldered on PCB, the test shall be done. Temperature : $-40 \pm 2^\circ\text{C}$ Testing time : 500 ± 12 hours
Vibration	Inductance variation to be within $\pm 10\%$ of the initial value. There shall be no mechanical damages.	After the samples shall be soldered on PCB, the test shall be done. Frequency : 10~500Hz Amplitude : 1.5mm Dimension and times : X, Y and Z directions for 2 hours each.
Share force	There shall be no mechanical damages.	After the samples shall be soldered on PCB, the test shall be done. Share force : 10 N
Drop	There shall be no remove to PC board.	After the samples shall be soldered on PCB and attach to the weight JIG, the test shall be done. Weight : 150g Drop height : 1.5m Direction : 6 directions / 1 cycle n of drop cycles : 15 cycles

Mounting Condition :

PCB Thickness : 1.6mm

Reflow Profile, Land Pattern and Screen thickness

: Refer to the 7. Recommended footprint and 8. Recommended reflow pattern on P5

Solder : Sn-3Ag-0.5Cu (M705)

TDK Corporation	REF. No. C519NAA00003	PAGE. 4 / 7
-----------------	--------------------------	----------------

7.Recommended footprint

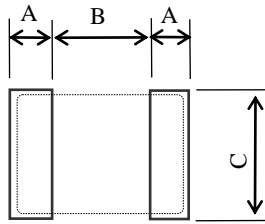

Unit : mm

Mark	A	B	C
TDK Reference	0.6	1.2	1.2
Possible to replace	0.8	0.5	1.3

Screen thickness : 0.08 mm

8.Recommended reflow pattern (Please use this product by reflow soldering)

8-1. Profile for Pb-free solder

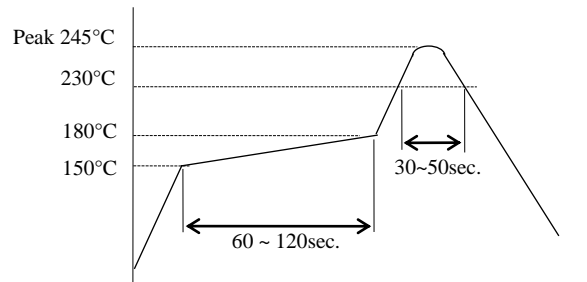

9.Packaging

The packaging must be done not to receive any damage transporting and storing.

The following matters are mentioned on bar code label.

- 1) Your product part number
- 2) Our product identification
- 3) Shipment number*
- 4) Quantity
- 5) Shipment day

*Shipment number[e.g.]

OO OO O OOOOO OO
 (1) (2) (3) (4) (5)

- (1)Our control number
- (2)Last digit of A.D
- (3)Shipment month (A ~ H : Jan. ~ Aug. , J ~ M : Sep. ~ Dec.)
- (4)Sequence number
- (5)Control mark

10.Attention in case of using

- 1) In case of using this product, please avoid following matters.

Splashing water or salt water

Dew condenses

Toxic gas (Hydrogen sulfide, Sulfurous acid, Chlorine, Ammonia, etc.)

Vibrations or shocks which exceed the specified condition

- 2) Please be careful for the stress to this product by board flexure or something after the mounting.
- 3) This product is only for reflow soldering. (is not available for flow soldering)
- 4) Please do enough packaging test in case of using.

11.Packaging form
11-1.Tape dimensions

Carrier tape material : Polystyrene

Cover tape material : Polystyrene

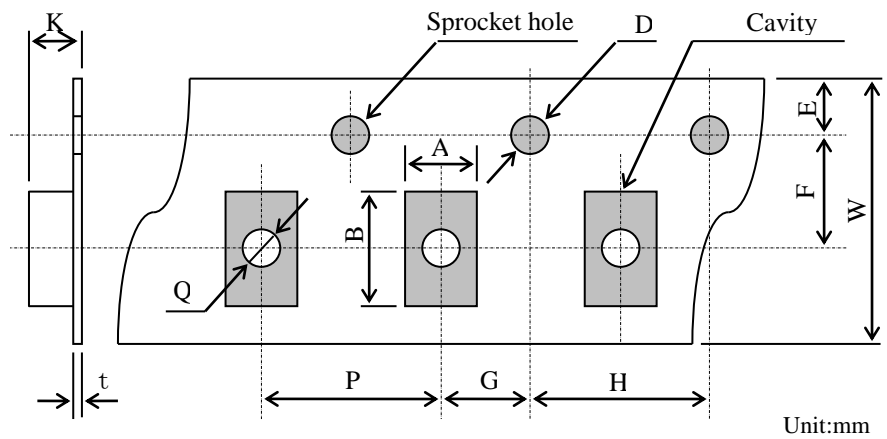

Unit:mm

Mark	A	B	D	E	F	G	H
Dim.	1.55+/-0.10	2.35+/-0.10	1.50+0.10/0	1.75+/-0.10	3.50+/-0.05	2.00+/-0.05	4.00+/-0.10
Mark	K	P	Q	t	W		
Dim.	1.10+/-0.05	4.00+/-0.10	1.00 min	0.25+/-0.05	8.00+/-0.20		

11-2.Reel dimensions

Unit:mm

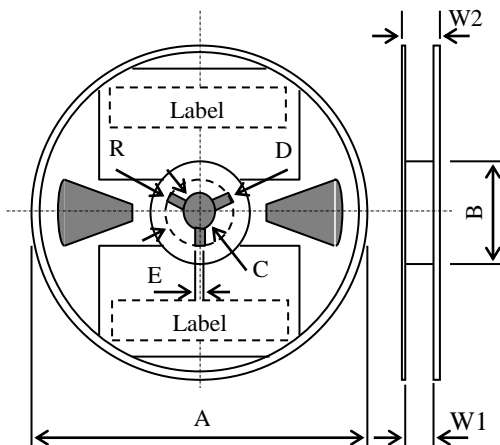

Mark	A	B	C	D
Dim.	φ180.0+/-2.0	φ60.0min.	φ13.0+/-0.2	φ21.0+/-0.8
Mark	E	W1	W2	R
Dim.	2.0+/-0.5	8.4+2.0/0	14.4max.	1.0

* Shaded portion is hole

* Reel material : Polystyrene

11-3. Shape of packing

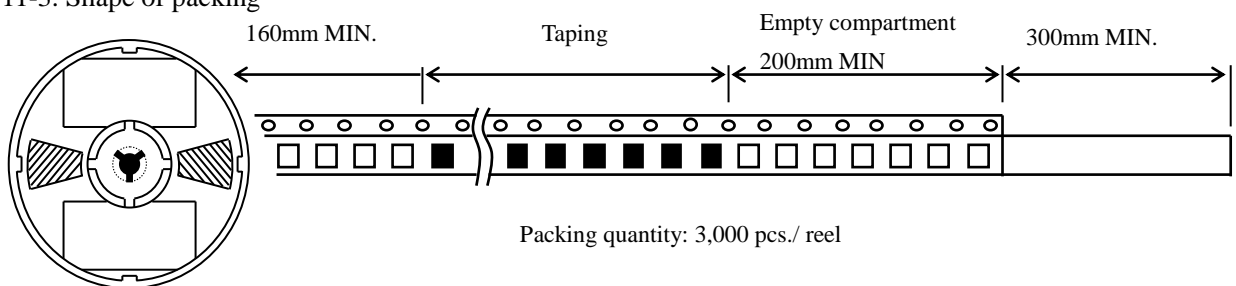

11-4.Cover tape peel strength

The force for tearing off cover tape is 0.1~0.7(N) in the arrow direction at the following conditions.

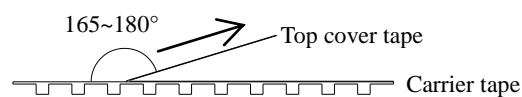

INSTRUCTIONS IN USING THIS PRODUCT

Please read the instructions here before you use this product.

INSTRUCTIONS ON SAFETY

When use the products, be careful to mention below for safety using.



CAUTION!

STORAGE

- * Store this product under the conditions which are defined in the catalogue or the instruction book.
Confirm the soldering property before using if you have stored the product over the conditions which are defined in the catalogue or the instruction book.
- * Don't store this product under the influence of the poisonous gases (such as hydrogen sulfide, sulfuric acid, chlorine and ammonia gas).
- * Avoid the direct rays of the sun and dew condensation.

USING CONDITIONS

- * Use this product under the conditions which are defined in the catalogue or the instruction book.
Temperature range and soldering property are especially to be noticed.
- * This product is designed for public welfare. If you are to use it for other purposes and if it is beyond the conditions in the instruction book, you should make a good examination beforehand.
- * Don't use this product in the place.
 - Exposed to water or seawater.
 - With dew condensation.
 - Under the influence of the poisonous gases (such as hydrogen sulfide, Sulfuric acid, chlorine and ammonia gas).
 - With vibrations and impulses which are not defined in the instruction book.
- * When soldering is modified after it is located on a base plate, you should confirm the conditions which are defined in the catalogue or the instruction book.
If it is heated excessively, the product may have troubles such as short circuit, rough contact, lowering of a property and shortening of its tenure.
- * Do the good washing after soldering and make sure there are no fluxes left.
- * Dry up after washing
- * Don't use the product if it is mechanically impacted by dropping and so on.
- * Pay attention to stresses to the product by flexions after it is located on a base plate.

APPLICATION

The products listed on this specification sheet are intended for use in general electronic equipment (AV equipment, telecommunications equipment, home appliances, amusement equipment, computer equipment, personal equipment, office equipment, measurement equipment, industrial robots) under a normal operation and use condition.

The products are not designed or warranted to meet the requirements of the applications listed below, whose performance and/or quality require a more stringent level of safety or reliability, or whose failure, malfunction or trouble could cause serious damage to society, person or property. Please understand that we are not responsible for any damage or liability caused by use of the products in any of the applications below or for any other use exceeding the range or conditions set forth in this specification sheet.

- | | |
|---|--|
| 1) Aerospace/Aviation equipment | 6) Transportation control equipment |
| 2) Medical equipment which directly endanger human life | 7) Military equipment |
| 3) Power-generation control equipment | 8) Power-generation control equipment |
| 4) Atomic energy-related equipment | 9) Other applications that are not considered general-purpose applications |
| 5) Seabed equipment | |

If you intend to use the products in the following applications, please contact our sales office.

Transportation equipment (cars, electric trains, ships, etc.), Public information-processing equipment, Electric heating apparatus / burning equipment, Disaster prevention/crime prevention equipment

When using this product in general-purpose applications, you are kindly requested to take into consideration securing protection circuit/equipment or providing backup circuits, etc., to ensure higher safety.

X-ON Electronics

Largest Supplier of Electrical and Electronic Components

Click to view similar products for [Fixed Inductors](#) category:

Click to view products by [TDK](#) manufacturer:

Other Similar products are found below :

[MLZ1608M6R8WTD25](#) [MLZ1608N6R8LT000](#) [MLZ1608N3R3LTD25](#) [MLZ1608N3R3LT000](#) [MLZ1608N150LT000](#)
[MLZ1608M150WTD25](#) [MLZ1608M3R3WTD25](#) [MLZ1608M3R3WT000](#) [MLZ1608M150WT000](#) [MLZ1608A1R5WT000](#)
[MLZ1608N1R5LT000](#) [B82432C1333K000](#) [PCMB053T-1R0MS](#) [PCMB053T-1R5MS](#) [PCMB104T-1R5MS](#) [CR32NP-100KC](#) [CR32NP-151KC](#) [CR32NP-180KC](#) [CR32NP-181KC](#) [CR32NP-1R5MC](#) [CR32NP-390KC](#) [CR32NP-3R9MC](#) [CR32NP-680KC](#) [CR32NP-820KC](#)
[CR32NP-8R2MC](#) [CR43NP-390KC](#) [CR43NP-560KC](#) [CR43NP-680KC](#) [CR54NP-181KC](#) [CR54NP-470LC](#) [CR54NP-820KC](#) [CR54NP-8R5MC](#)
[MGDQ4-00004-P](#) [MGDU1-00016-P](#) [MHL1ECTTP18NJ](#) [MHL1JCTTD12NJ](#) [PE-51506NL](#) [PE-53601NL](#) [PE-53630NL](#) [PE-53824SNLT](#) [PE-62892NL](#) [PE-92100NL](#) [PG0434.801NLT](#) [PG0936.113NLT](#) [PM06-2N7](#) [PM06-39NJ](#) [HC2LP-R47-R](#) [HC2-R47-R](#) [HC3-2R2-R](#) [HC8-1R2-R](#)