

20-40A DIN Rail Redundancy Module

Features

- ◆ Compact Size
- ◆ Low 200mV Voltage Drop
- ◆ Current Balance Indicator Option
- ◆ Isolated Alarm Signals
- ◆ 50% Peak Current Rating

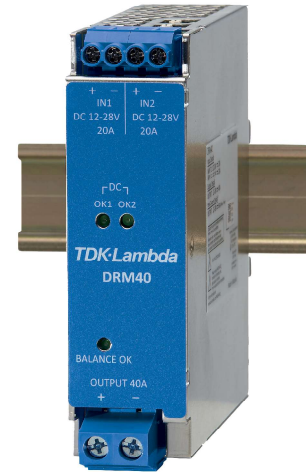

Key Market Segments & Applications



Specifications			
Model		DRM40	DRM40B
Input Voltage Range	VDC	10 - 30VDC	
Number of inputs	-	Two	
Maximum Input Current	A	2 x 20A, total 60A peak	
Peak Input Current	A	2 x 30A for 4s maximum, 0.35 duty cycle	
Maximum Output Current	A	40A	
Peak Output Current	A	60A for 4s maximum, 0.35 duty cycle	
Internal Power Loss (typ)	W	8W at 40A	
Input to Output Voltage Drop	VDC	0.2V at 40A	
Maximum Reverse Voltage	VDC	40VDC	
Overcurrent protection	-	None	
Overvoltage protection	-	None	
Operating Temperature	°C	-40 to +70°C standard mounting orientation	
Storage Temperature	°C	-40 to +85°C	
Humidity	%RH	5 - 95%RH operating and storage (non condensing)	
Cooling	-	Convection	
Output Good Indicators	-	Two green LEDs indicating each input is "good"	None
Current Balance Indicators	-	Green LED indicates balanced current	None
Input Voltage Alarms	-	Opto-isolated relays are off when input is below threshold	None
Withstand Voltage	VDC	Input or Output - Chassis 707VDC for 1 minute	
Isolation Resistance	MΩ	Input or Output - Chassis >100MΩ at 25°C, 70%RH and 500VDC	
Vibration	-	None operating, 10 - 55Hz (sweep for 1min), 19.6m/s ² (2G) Constant, X, Y, Z 1hour each	
Shock	-	<196m/s ² (20G)	
Safety Agency Certifications	-	IEC/UL/CSA/EN60950-1, IEC/UL/CSA/EN62368-1, UL508, CE mark (LVD, EMC and RoHS)	
Size W x D x H)	mm/in	35 x 125 x 124mm, 1.18 x 4.91 x 4.87"	
Weight	g	330	
Warranty	Yrs	Five Years	

Note: See Installation Manual for full details, test methods of parameters and application notes

Block Diagrams

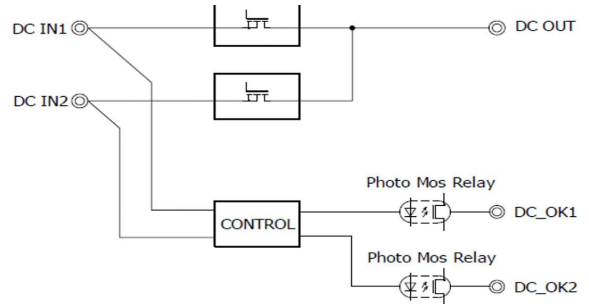
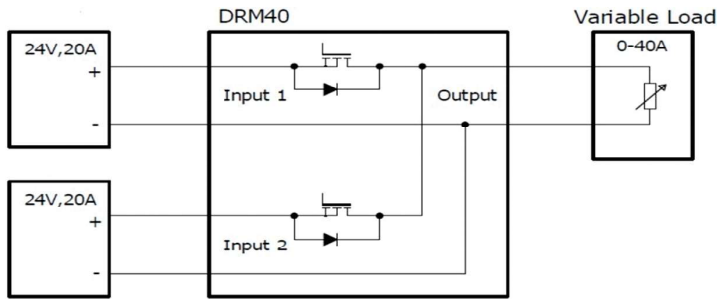

Outline Drawing DRM40

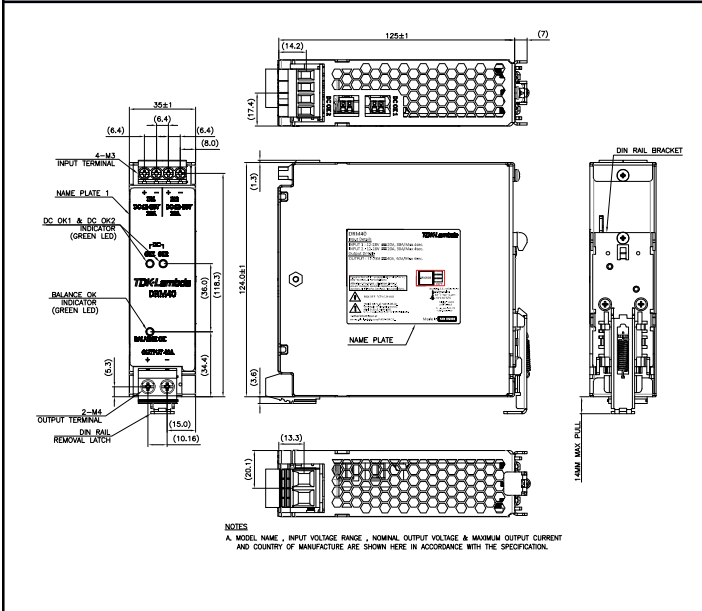

Outline Drawing DRM40B

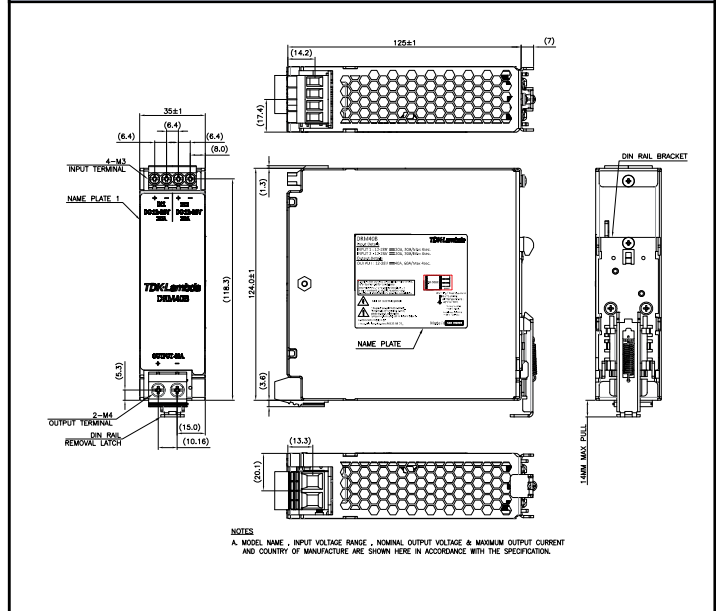

For Additional Information, please visit
<https://product.tdk.com/en/power/>



X-ON Electronics

Largest Supplier of Electrical and Electronic Components

Click to view similar products for [Isolated DC/DC Converters](#) category:

Click to view products by [TDK-Lambda](#) manufacturer:

Other Similar products are found below :

[ESM6D044440C05AAQ](#) [FMD15.24G](#) [PSL486-7LR](#) [Q48T30020-NBB0](#) [18362](#) [JAHW100Y1](#) [SPB05C-12](#) [SQ24S15033-PS0S](#) [19-130041](#)
[CE-1003](#) [GQ2541-7R](#) [RDS180245](#) [MAU228](#) [J80-0041NL](#) [DFC15U48D15](#) [XGS-0512](#) [XGS-1205](#) [XGS-1212](#) [XGS-2412](#) [XGS-2415](#) [XKS-](#)
[1215](#) [06322](#) [NCT1000N040R050B](#) [SPB05B-15](#) [SPB05C-15](#) [L-DA20](#) [DCG40-5G](#) [QME48T40033-PGB0](#) [XKS-2415](#) [XKS-2412](#) [XKS-1212](#)
[XKS-1205](#) [XKS-0515](#) [XKS-0505](#) [XGS-2405](#) [XGS-1215](#) [XGS-0515](#) [73-551-5038I](#) [AK1601-9RT](#) [VI-N61-CM](#) [VI-R5022-EXWW](#) [PSC128-](#)
[7iR](#) [RPS8-350ATX-XE](#) [DAS1004812](#) [PQA30-D24-S24-DH](#) [VI-M5F-CQ](#) [VI-LN2-EW](#) [VI-PJW01-CZY](#) [CK2540-9ERT](#) [AK-1615-7R](#)