

1600W 1U Front End Power Supplies

<https://product.tdk.com/en/power/hfe>
www.emea.lambda.tdk.com/uk/products/hfe



The HFE1600 AC-DC industrial power supplies can be operated in a hot-swap redundant configuration, or used to provide up to 7,600W of bulk power. Up to five power supplies can be fitted in a variety of 19" 1U high racks, for configuration as a single or dual output. The HFE supplies have internal ORing MOSFETs and current share for automatic parallel operation. Communication is possible with the power supplies using the optional isolated PMBus™ (I²C) interface or a plug-in LAN module. AC fail, DC good, remote output adjust, remote on/off and a 12V auxiliary output are fitted as standard.

Features	Benefits
• Internal ORing MOSFET and Current Share	• Suitable For N+1 Redundancy
• Up to 7600W in 1U Rack	• Utilizes Less System Space
• Full Array of Signals Available	• Easy Remote Monitoring
• PMBus™ (I ² C) and LAN options	• Industry Standard Communication Interfaces
• Analog Output Adjustment	• Simple External Resistance or Voltage Connection

Model Selector						
Model	Output Voltage (V)	Adjustment Range (V) ⁽¹⁾	Max Current (A) (Vin>170Vac)	Max Power (W) (Vin>170Vac)	Max Current (A) (100<Vin<170Vac) ⁽²⁾	Max Power (W) (100<Vin<170Vac) ⁽²⁾
HFE1600-12	12	9.6 - 13.2	133	1596	100	1200
HFE1600-24	24	19.2 - 29	67	1608	50	1200
HFE1600-32	32	25.6 - 38.4	47	1500	37.5	1200
HFE1600-48	48	38.4 - 58	33	1584	25	1200

HFE1600-	12	/	S
	Output voltage 12, 24, 32, 48		blank No PMBus™ / I ² C S PMBus™ / I ² C interface

Model Selector (Racks and LAN)		
Model	Description	Maximum Rack Current
HFE1600-S1U	Five slot 19" rack, IEC320-C16 input connectors (5)	266A each side (532A total)
HFE1600-S1U-TB	Five slot 19" rack, terminal block input connectors (5)	266A each side (532A total)
HFE1600/BP	One slot blanking panel, four provided with each rack	-
HFE/C15U	AC Power cord, 2.0m long, one per power supply required	-
HFE1600-D1U	Four slot (two isolated pairs), dual output 19" rack, IEC320 input	266A each side (532A total)
HFE1600-D1U-TB	Four slot (two isolated pairs), dual output 19" rack, terminal block input	266A each side (532A total)
HFE1600-LAN	Plug in LAN module. Takes up one rack slot. For use with /S power supplies only.	-

Specifications					
Model		HFE1600-12	HFE1600-24	HFE1600-32	HFE1600-48
Input					
Input Voltage range (2)	Vac	85 - 265			
Input Frequency	Hz	47 - 63			
Input Current (Max) 115/230Vac	A	14.2 / 8.1			
Inrush Current	A	<35			
Leakage Current	mA	Less than 0.75/1.5mA at 100/230Vac, 60Hz			
Power Factor Correction	-	EN61000-3-2, PF >0.98 at full load			
Harmonic Compliance	-	Meets IEC61000-3-2			
Hold up time	ms	>10ms, 100/230Vac input, 80% loading			
Efficiency (4)	%	87 / 90	88 / 90	88 / 90	89 / 92
Conducted & Radiated EMI	-	EN55022 & FCC part 15; Conducted class B, Radiated class A			
Line Dip	-	Complies with SEMI F47 (200Vac line only)			
Immunity	-	See immunity section			
Safety Agency Certifications	-	IEC/UL/CSA/EN62368-1, 60950-1, CE Mark			

Immunity				
Test	Standard	Test Level	Criteria	Notes
ESD	EN61000-4-2	2,3	B	-
Radiated Susceptibility	EN61000-4-3	2	A	-
Electrical Fast Transient Burst	EN61000-4-4	2	B	-
Surge	EN61000-4-5	3,4	B	-
Conducted Susceptibility	EN61000-4-6	2	A	-
Magnetic Fields	EN61000-4-8	4	A	-
Voltage Dips and Input Interruptions	EN61000-4-11	>95% for 0.5 cycles	B	-
		30% for 25/30 cycles	C	-
		>95% for 250/300 cycles	C	-

Specifications					
Model		HFE1600-12	HFE1600-24	HFE1600-32	HFE1600-48
Output					
Line Regulation	mV	30	60	80	120
Load Regulation	mV	60	120	160	240
External Load Capacitance	uF/A	1000			
Ripple & Noise (1)	mV	240	240	320	480
Temperature Coefficient	%/°C	<0.02			
Minimum Load	-	No minimum load required			
Overcurrent Protection	%	105-120			
Overvoltage Protection (1)	%	110% (Tracking). Cycle AC to reset or utilize Remote On/Off			
Overtemperature Protection (1)	-	Shutdown with automatic reset. Warning signal provided.			
Remote Sense Compensation	V/wire	0.25	0.5	0.75	1.0
Remote On/Off	-	Unit ON: 0-0.6V or short, OFF: 2-15V or open circuit			
Remote Adjust	-	By either external 0-5V signal or 1k ohm potentiometer			
AC Fail Signal	-	Open Collector, ON when AC is within 85-270Vac			
DC Good Signal	-	Open Collector, ON when output is above 85 to 95% of setpoint (tracking)			
Auxiliary Output	-	11.2 - 12.5V, 0.5A, 240mV ripple and noise			
Communication	-	Optional isolated PMBus™ (I ² C) interface (/S suffix) or plug-in LAN module. See model selectors			
Indicators	-	DC OK - Green- >90% ±5% of set output voltage; AC OK - Green - 85 to 270Vac ; Green / Red LED			
Parallel Operation (1)	-	Yes, single wire current share, up to 90% accuracy (load dependant), up to 10 units			
Series Operation (1)	-	Two racks maximum (external diodes required)			

Specifications					
Model		RFE1600-12	RFE1600-24	RFE1600-32	RFE1600-48
Environmental					
Operating Temperature	°C	-10 to +50: 100% load; +50 to +60 derate: 2%/°C of load; +60 to +70 derate: 2.5%/°C of load. For models with reverse air contact factory.			
Storage Temperature	°C	-30 to +85			
Humidity (non condensing)	%RH	Operating: 10 - 90, Storage: 10 - 95			
Cooling	-	Internal variable speed fans. Airflow enters from the front. Contact factory for reverse airflow option.			
Altitude	m	3000 max. Derate output current 2%/100m above 2000m.			
Withstand Voltage	-	I/P to O/P 3kVac, I/P to GND 2kVac. O/P to GND: HFE1600-12, -24V 500Vac, HFE1600-48 2250Vdc 1 min, (POE)			
Isolation Resistance	MΩ	>100 at 25°C, 70%RH & Output to Ground 500Vdc			
Vibration (Non-operating)	-	Meets IEC60068-2-64 (Basic Transportation)			
Shock (Non-operating)	-	Meets IEC60068-2-27 (Basic Transportation)			
Other					
Weight (Typ)	g	Power Supply: 1550, Rack: 4800			
Size (LxWxH)	mm	Power Supply: 300 x 85 x 41; Rack: 365 x 445 x 43.6			
Size (LxWxH)	Inches	Power Supply: 11.8 x 3.35 x 1.61; Rack: 14.4 x 17.5 x 1.72			
PMBus™ / I ² C Interface (1)	-	Isolated from output, Add suffix /S, PMBus™ compatible			
MTBF - Telcordia	Hours	210,143			
Warranty	Years	Three			

Notes

- (1) See installation manual for detailed specifications and test methods
- (2) Derate output power linearly 1%/V from 100Vac to 85Vac input
- (3) Reverse air - contact factory
- (4) At 75% load, 115 / 230Vac input

Outline Drawing HFE1600

FRONT VIEW
 21.4, 85.0 ±0.5, 42.2, 20.4, 2.2 ±0.2, 40.8 ±0.3

REAR VIEW
 12.1, 43.0, IN/OUT CONNECTOR SEE NOTE 1

IN/OUT CONNECTOR REAR VIEW

PIN No	FUNCTION	PIN No	FUNCTION
A1 ~ A5	-V OUT	B12	INHIBIT
A6 ~ A10	+V OUT	B13	SCL (PMBus)
B1	SIGNAL RETURN	B14	A1 (PMBus)
B2	PS EXIST	B15	DC OK
B3	AUX_OUT (+12V)	B16	A0 (PMBus)
B4	-SENSE	B17	SDA (PMBus)
B5	A2 (PMBus)	B18	TEMP_ALARM
B6	CURRENT SHARE	B19	V REFERENCE OUT
B7	ENABLE	B20	SMB_ALERT (PMBus)
B8	VOLTAGE PROGRAMMING	B21	AC FAIL
B9	+SENSE	C1	CHASSIS GROUND
B10	A3 (PMBUS)	C2	AC NEUTRAL
B11	NC	C3	AC LINE

TOLERANCES/#

1-16mm	0.1
16.1-63mm	0.2
63.1-250mm	0.3
250.1-1000mm	0.5
ANGLE	±0.3°

NOTES

- CONNECTOR TYPE: PCIM34W13M400A1/AA, POSITRONIC. FEMALE CONNECTOR TYPE: PCIM34W13F400A1/AA.
- LED INDICATORS. REFER TO INSTRUCTION MANUAL.
- MOUNTING SCREWS MUST NOT PENETRATE MORE THAN 7mm INTO THE UNIT.
- LABEL WITH MODEL NAME, INPUT AND OUTPUT RATING, SAFETY APPROVAL SYMBOLS AND PLACE FOR DATA CODE AND EU REPRESENTATIVE ADDRESS LABEL.
- ALLOW MINIMUM 50 mm OF UNRESTRICTED AIR SPACE AT THE REAR OF UNIT. DO NOT OBSTRUCT AIR FLOW TO THE UNIT FRONT PANEL.
- REFER TO INSTRUCTION MANUAL FOR SETTING DETAILS.
- TO EXTRACT THE POWER SUPPLY, ELEVATE AND HOLD THE RELEASE KNOB AND PULL THE EXTRACTION HANDLE.

Outline Drawing HFE1600-S1U

NOTES

- MOUNTING HOLES FOR RACK 19". USE M6x12 SCREWS TO FIX THE UNIT TO A RACK.
- USE NUT FLAT WASHER AND SPRING WASHER FOR LOAD WIRES FIXING. USE LUG FOR STUD M6 FOR LOAD WIRES. RECOMMENDED TORQUE: 49-56 kgf.cm.
- TO FIX THE MOUNTING BRACKET TO THE CHASSIS USE M5x10 SEMS SCREWS. RECOMMENDED TIGHTENING TORQUE 27-31 kgf.cm. SCREWS MUST NOT PENETRATE THE CHASSIS MORE THAN 6.0 mm.
- REFER TO INSTRUCTION MANUAL FOR SETTING DETAILS.
- MODEL NAME, VOLTAGE AND CURRENT RATING AND SAFETY APPROVAL SYMBOLS WILL BE SHOWN HERE ACCORDING TO THE SPECIFICATION.
- THE HFE-S1U RACK IS SHOWN WITH 5 HFE1600 UNITS INSTALLED.
- EU REPRESENTATIVE ADDRESS LABEL
- IEC 60417-6042 AND IEC 60417-6172
- SAFETY SYMBOLS LABELS

SIGNALS & CONTROL CONNECTOR PINS ASSIGNMENT
 CONNECTOR DESCRIPTION: IPL1-120-01-S-D-RA-K(SAMTEC)
 MATING CONNECTOR: IPD1-20-D-K (SAMTEC)

1	-SENSE	11	TEMP_ALM_A	21	DC_OK_A	31	INHIBIT_E
2	-LS	12	TEMP_ALM_B	22	DC_OK_B	32	PS_EXIST_A
3	+SENSE	13	TEMP_ALM_C	23	DC_OK_C	33	PS_EXIST_B
4	+LS	14	TEMP_ALM_D	24	DC_OK_D	34	PS_EXIST_C
5	V_RPOG	15	TEMP_ALM_E	25	DC_OK_E	35	PS_EXIST_D
6	TRIM	16	AC_FAIL_A	26	SIGNAL RETURN	36	PS_EXIST_E
7	NC	17	AC_FAIL_B	27	INHIBIT_A	37	SIGNAL RETURN
8	+5VIV_REF (*1)	18	AC_FAIL_C	28	INHIBIT_B	38	+12V_AUX
9	+5VIV_REF (*1)	19	AC_FAIL_D	29	INHIBIT_C	39	ENABLE
10	-SENSE	20	AC_FAIL_E	30	INHIBIT_D	40	SIGNAL RETURN

*1. FOR HFE1600-xx/S WITH PMBUS OPTION : V_REF
 FOR HFE1600-xx WITHOUT PMBUS OPTION: 5V

ACCESSORIES LIST IN SHEET 2

Outline Drawing HFE1600-S1U-TB

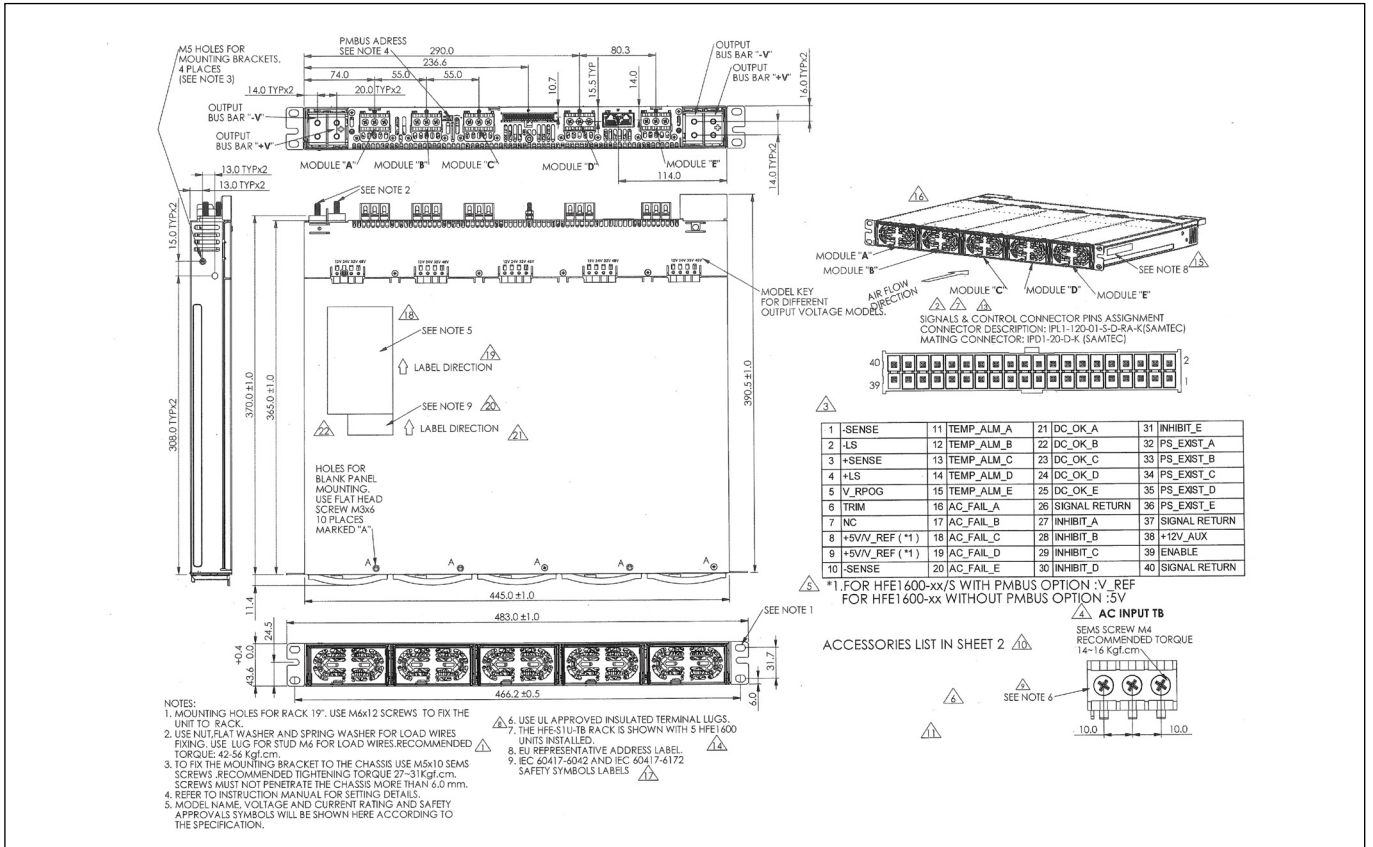

Outline Drawing HFE1600-D1U

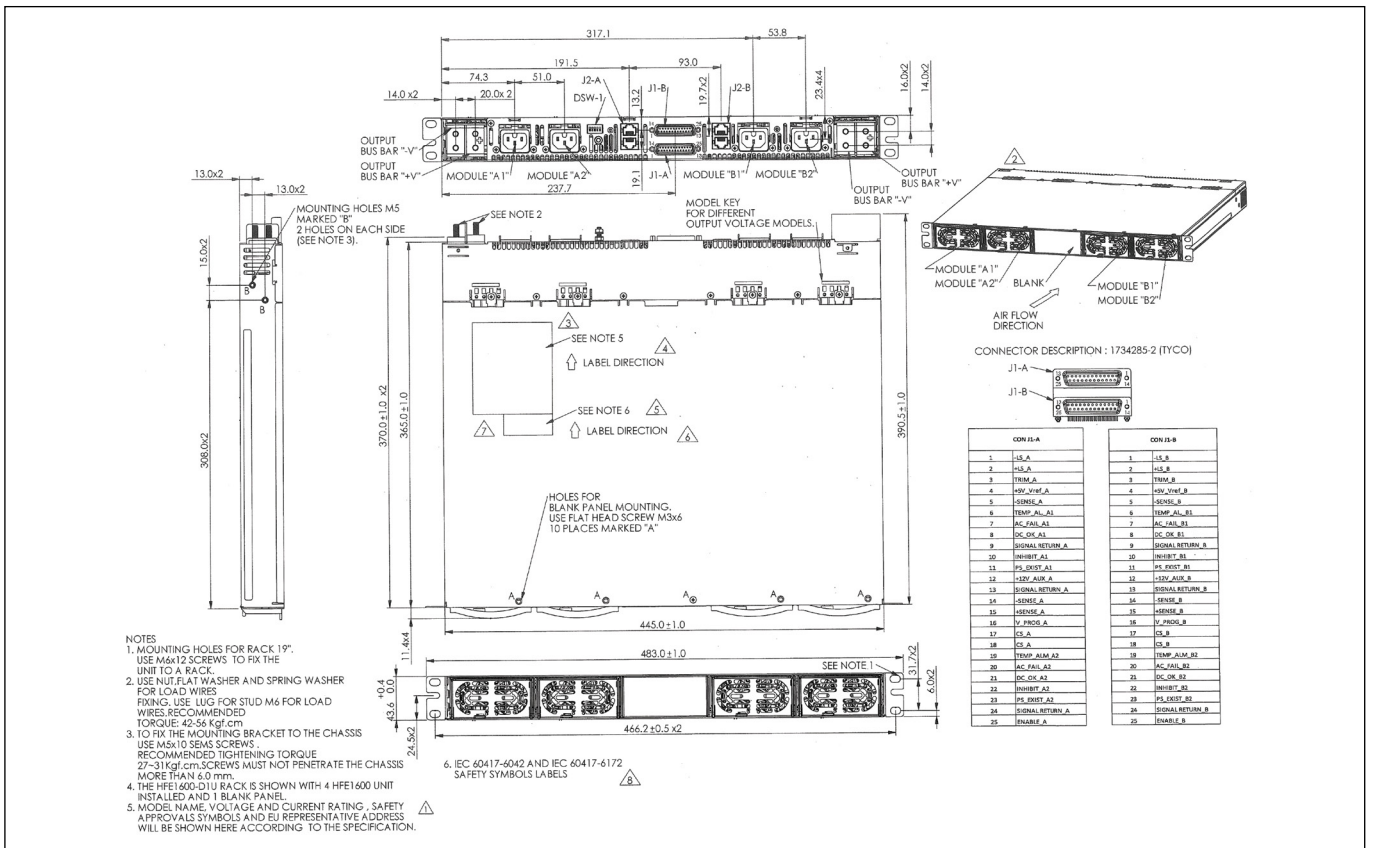

Outline Drawing HFE1600-D1U-TB

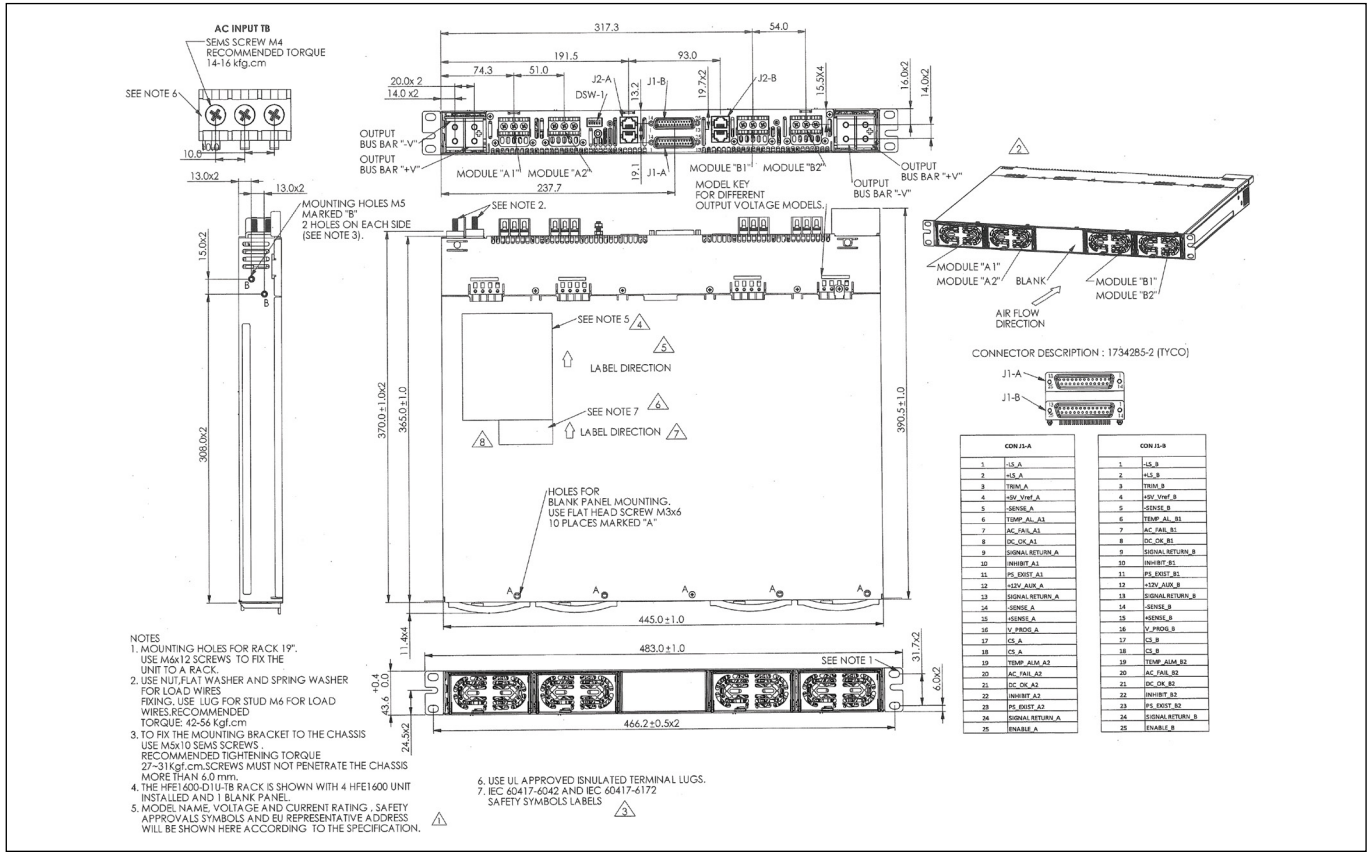

Outline Drawing HFE1600-LAN

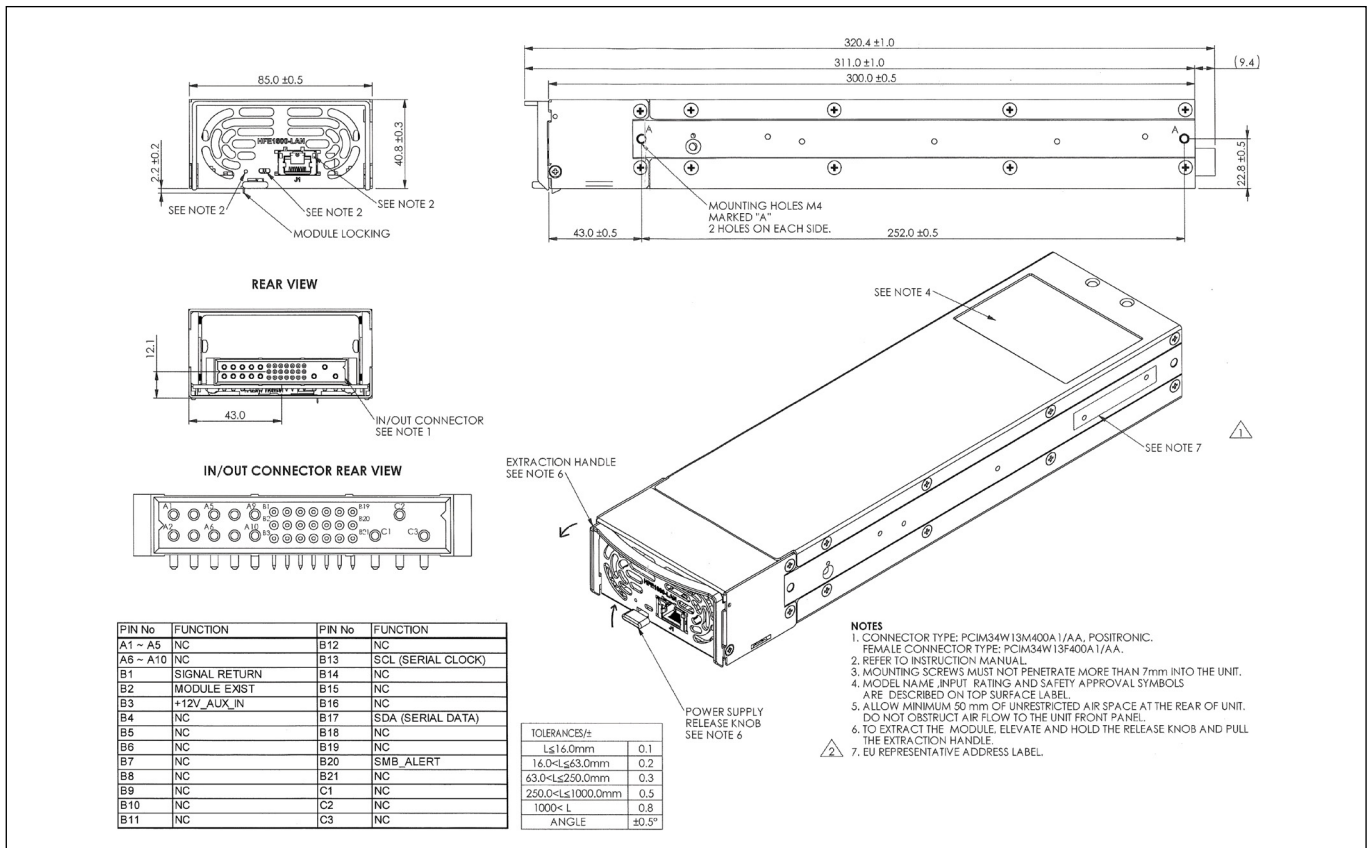



TDK-Lambda France SAS

Tel: +33 1 60 12 71 65
france@fr.tdk-lambda.com
www.emea.lambda.tdk.com/fr



Italy Sales Office

Tel: +39 02 61 29 38 63
info.italia@it.tdk-lambda.com
www.emea.lambda.tdk.com/it



Netherlands

info@nl.tdk-lambda.com
www.emea.lambda.tdk.com/nl



TDK-Lambda Germany GmbH

Tel: +49 7841 666 0
info.germany@de.tdk-lambda.com
www.emea.lambda.tdk.com/de



Austria Sales Office

Tel: +43 2256 655 84
info@at.tdk-lambda.com
www.emea.lambda.tdk.com/at



Switzerland Sales Office

Tel: +41 44 850 53 53
info@ch.tdk-lambda.com
www.emea.lambda.tdk.com/ch



Nordic Sales Office

Tel: +45 8853 8086
info@dk.tdk-lambda.com
www.emea.lambda.tdk.com/dk



TDK-Lambda UK Ltd.

Tel: +44 (0) 12 71 85 66 66
info@uk.tdk-lambda.com
www.emea.lambda.tdk.com/uk



TDK-Lambda Ltd.

Tel: +9 723 902 4333
info@tdk-lambda.co.il
www.emea.lambda.tdk.com/il



C.I.S.

Commercial Support:

Tel: +7 (495) 665 2627

Technical Support:

Tel: +7 (812) 658 0463
info@tdk-lambda.ru
www.emea.lambda.tdk.com/ru



TDK-Lambda Americas

Tel: +1 800-LAMBDA-4 or 1-800-526-2324
powersolutions@us.tdk-lambda.com
www.us.lambda.tdk.com



TDK Electronics do Brasil Ltda

Tel: +55 11 3289-9599
sales.br@tdk-electronics.tdk.com
www.tdk-electronics.tdk.com/en



TDK-Lambda Corporation

Tel: +81-3-6778-1113
www.jp.lambda.tdk.com



TDK-Lambda (China) Electronics Co. Ltd.

Tel: +86 21 6485-0777
powersolutions@cn.tdk-lambda.com
www.lambda.tdk.com.cn



TDK-Lambda Singapore Pte Ltd.

Tel: +65 6251 7211
tts.mkt@sg.tdk-lambda.com
www.sg.lambda.tdk.com



TDK India Private Limited, Power Supply Division

Tel: +91 80 4039-0660
mathew.philip@in.tdk-lambda.com
www.sg.lambda.tdk.com



X-ON Electronics

Largest Supplier of Electrical and Electronic Components

Click to view similar products for [Rack Mount Power Supplies](#) category:

Click to view products by [TDK-Lambda](#) manufacturer:

Other Similar products are found below :

[HFE2500BP](#) [PET1300-12-054NAE](#) [HFE1600BP](#) [73-311-0001](#) [73-317-0148](#) [73-495-0233](#) [750-1016](#) [SFP450-S101G](#) [FUP550SNRPS](#)
[VRA.00335.0](#) [VRA.00334.0](#) [VRA.00333.0](#) [HFE1600-KIT](#) [CP841A_3C3R_S](#) [CC109146503](#) [RKP-1UI](#) [PFE1100-12-054ND](#) [FND300-1012G](#)
[73-951-0001T](#) [73-954-0001C](#) [DS550DC-3](#) [DRP-3200-48](#) [RCP-2000-24](#) [TSR10](#) [TET2000-12-086NA](#) [PET2000-12-074RA](#) [RCP-MU](#) [RCP-](#)
[3K1UI-12](#) [605-10144-2AC](#) [6609006-5](#) [D1U54P-W-1200-12-HC4PC](#) [DS450DC-3](#) [DS650DC-3](#) [LCM300Q-T](#) [LCM300W-T-4](#) [LCM600N-T-](#)
[4-A](#) [FNP600-48G](#) [FNR-3-48G](#) [FNR-5-12G](#) [SPSPFE3-05G](#) [TET3200-12-069RA](#) [IEC-A-1](#) [FXX1600PCRPS 915606](#) [DHP-1UT-A](#) [DRP-](#)
[3200-24](#) [RCP-1000-12](#) [RCP-1000-12-C](#) [RCP-1000-24](#) [RCP-1000-24-C](#) [RCP-1000-48](#)