

RKE SERIES

Single phase input / single output 1500W



■ Features

- Ultra-compact high-capacity front-end power supply
- Meeting the standards for the harmonics current limiter
- Complying with the semiconductor-process device voltage surge immunity specifications in the SEMI regulations
- Equipped with broad-range output voltage adjusting function (36V type: 6.0-55.0V)
- Parallel operation and master/slave operation applicable
- Approved by safety standards (UL, C-UL, TÜV), complying with Electrical Appliance and Material Safety Law, CE marking applicable

■ Model naming method

RKE 24 - 50R

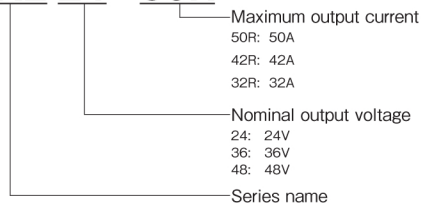

■ Applications

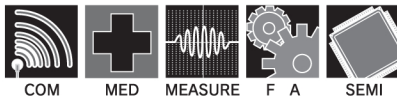

■ Conformity to RoHS Directive

This means that, in conformity with EU Directive 2002/95/EC, lead, cadmium, mercury, hexavalent chromium, and specific bromine-based flame retardants, PBB and PBDE, have not been used, except for exempted applications.

■ Product Line up

	1500W	
Output voltage	Output current	Model name
24V	50A	RKE24-50R
36V	42A	RKE36-42R
48V	32A	RKE48-32R

Last Time Buy November 2019

RKE1500W Specifications

Items/Units	MODEL	RKE24-50R	RKE36-42R	RKE48-32R		
Input	Voltage range (Nominal: 100-240VAC) (*7)	V	AC85-265			
	Frequency (Nominal: 50-60 single phase)	Hz	47-66			
	Power factor (100/240VAC)(typ)		0.95			
	Efficiency (100VAC)(typ)	%	81	83		
	Efficiency (200VAC)(typ)	%	86	88		
	Current (200-240VAC)(max)	A	8	10		
	Surge current (100/200VAC)(typ)(*3)	A	15/30 20 max / 40 max			
	Leakage current (100/200VAC) (max)	mA	0.65/0.75			
Output	Nominal voltage	VDC	24	36	48	
	Maximum current (*1)	A	50	42	32	
	Maximum power (*9)	W	1200	1512	1536	
	Maximum line regulation (Within input voltage range)(max/typ)		0.2%/0.1%			
	Maximum load regulation (0-100% load)(max/typ)		2.0%/1.0%			
	Temperature coefficient (Ambient temperature -10°C - +65°C) (max/typ)	%	1.0/0.5			
	Warm Up Drift (max/typ)(*4)	%	0.5/0.2			
	Total regulation (max/typ)	%	± 3.2/ ± 1.6			
	Ripple (max) (*2)	mVp-p	200	300		
	Ripple noise (max) (*2)	mVp-p	300	400		
	Start-up time (100/240VAC)(typ)	ms	250			
	Hold-up Time (100/240VAC)(typ)	ms	30/20	17/10		
	Voltage adjustable range	VDC	16.8-31.2	25.2-55.0	33.6-55.0	
	Function	Over current protection (85-90VAC) (*6)	A	31-57.5	22.3-36.8	17-36.8
		Over current protection (90-170VAC) (*6)	A	36-57.5	26-48.3	20-36.8
Over current protection (170-265VAC) (*6)		A	52.5-57.5	44.1-48.3	33.6-36.8	
Over voltage protection (*5)		VDC	32-36.4	56-60		
Over temperature protection (*5)			Available			
Remote sensing			None			
Remote On/Off (*8)			Available			
Parallel operation			Applicable (Current balance function and master/slave operation are supported but synchronized operation is not supported.)			
Series operation			Applicable			
Operation indicator			Available (green LED)			
Variable output voltage (*10)			Available			
Monitoring signal			Available (power fail signal)			
Low output voltage detection (*9)			Available			
Environment	Operating temperature	°C	-10 to +65			
	Storage temperature	°C	-30 to +75			
	Operating humidity	%RH	10-95 (in conditions of a maximum 35°C in wet bulb temperature and non condensing should be ensured.)			
	Storage humidity	%RH	10-95 (in conditions of a maximum 35°C in wet bulb temperature and non condensing should be ensured.)			
	Vibration resistance		5-10Hz, 10 minutes sweep, 10mmp-p total amplitude, 3 directions, 1h for each, in non-operation 10-200Hz, 10 minutes sweep, 19.6m/s ² (2G) acceleration, 3 directions, 1h for each, in non-operation			
	Impact resistance		294m/s ² (30G), 11 ± 5ms, 3 directions, 3 times for each, in non-operation			
Insulation	Withstand voltage		For 1 minute at ordinary temperature and humidity Between input terminal and ground terminal: 2.0kVAC, 10mA cutout current Between input terminal and output terminal: 3.0kVAC, 10mA cutout current Between output terminal and ground terminal: 500VAC, 20mA cutout current			
	Insulation resistance		500VDC and 100MΩ or over at ordinary temperature and humidity Between input terminal and ground terminal, between input terminal and output terminal, and between output terminal and ground terminal			
Standards application	Safety standards		Approved by UL60950-1, CSA C22.2 No.60950-1 (C-UL), EN60950-1 (TUV), complying with Electrical Appliance and Materials Safety Law (meeting the regulations of creepage surface and spacial distance in item 8 of the appendix table)			
	Meeting the standard of PFHC		Complying with EN61000-3-2			
	EMI		Complying with FCC-Class B / VCCI-Class B / EN55011-B / EN55022-B			
Physical structure	Immunity		Complying with EN61000-4-2 Level 4, -3 Level 3, -4 Level 3, -5 Level 4, -6 Level 3, -8 Level 4, -11			
	Weight max	g	3,000			
	Dimensions (W x H x D)	mm	120 x 92 x 237			

In nominal input/output voltage, maximum output current, and Ta=25°C, if not specified separately.

(*1) The maximum output current value is that at between -10°C and +50°C. For use in outside this temperature range, derating is needed.

(*2) Twice the value in 100MHz and at between -10°C and 0°C.

(*3) In primary surge current, and 30s or over in input interval.

(*4) 30min to 8h after input voltage starts to be being applied.

(*5) Output voltage shutdown system is activated, and voltage resumes by restarting input or resetting RC.

(*6) Fixed current/voltage reduction system is activated, and voltage automatically resumes when causes are removed (output voltage is shut down if over current condition continues for 30 seconds or over.) Intermittent operation may be caused in 170VAC or lower.)

(*7) Derating is needed when in use with 170VAC or lower input voltage.

(*8) Short-circuit between +RC and -RC when not in use.

(*9) Output is shut down if the output voltage becomes 60% or lower of the set voltage (5V or lower for 36V) and it continues for 30s. Resumes by restarting input or resetting RC.

(*10) Short-circuit between REF and RV when not in use.

Recommended EMC Filter



RSEN-2020

Please refer to "TDK-Lambda EMC Filters" catalog.

Outline Drawing

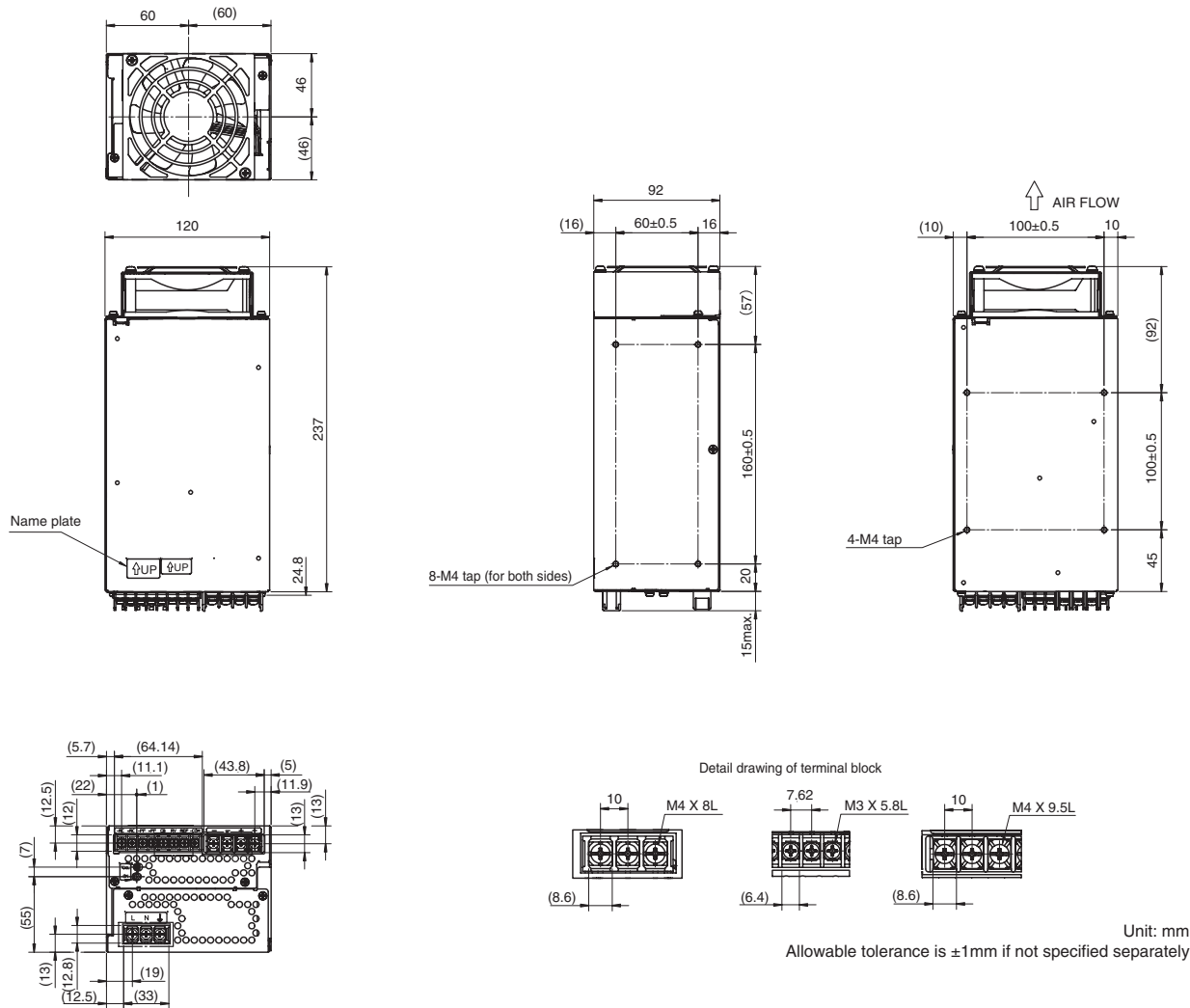

- Insertion depth of screws used in the M4 taps for mounting power supply should be 6mm or less from the surface of the product.

Terminals

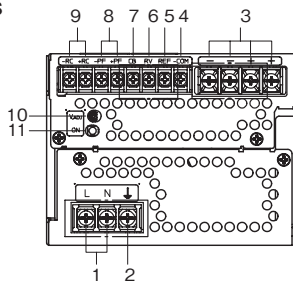

Terminal No.	Name and function	
1	AC input terminal (L, N)	Connects to AC.100-120 or AC.200-240V phases AC line.
2	Ground terminal (G)	Connects to the ground line. This is connected to the case.
3	DC output terminal (+, -)	Connects to the load line.
4	Signal common terminal	
5	Output voltage reference terminal (REF)	This is the terminal of reference voltage for output voltage control, and is used in master/slave operations or in use of output voltage varying function. Usually this terminal is short-circuited to the RV terminal with a short piece.
6	Output voltage adjusting terminal (RV)	Used for controlling output voltage by external signals.
7	Current balance terminal (CB)	Used in parallel operation of power supplies. In this case, mutually connect the (CB) and (-S) terminals of each unit.
8	Power fail terminal (+PF, -PF)	Emits the open mode signal when the output voltage becomes 80% or lower than the set voltage. Signals are also emitted when the output voltage is shut down due to activation of the detection circuit for over voltage protection of output, of the over temperature protection that stops the fans, or of the over current protection.
9	Remote On/Off terminal (+RC, -RC)	Output can be switched On and Off by opening/closing the connection between the RC terminals (output is off in open status). The RC terminal is floated. Usually the ±RC terminals is short-circuited with a short piece.
10	Output voltage trimmer (V _{ADJ})	Output voltage can be varied.
11	LED output indicator (green)	The LED is lit green when output voltage is generated.

Derating Curve

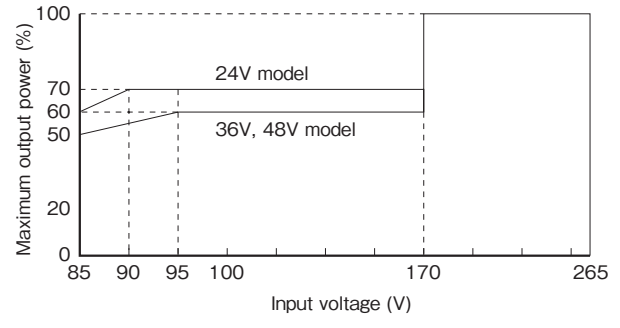
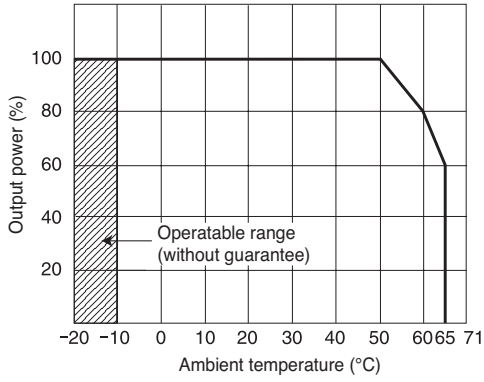

Block Diagram

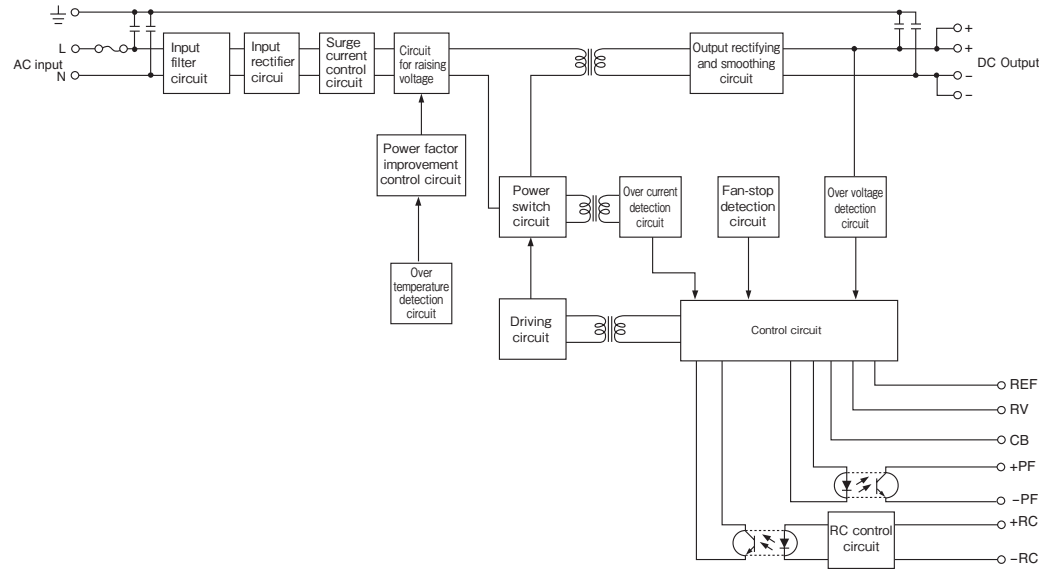

Sequence Time Chart

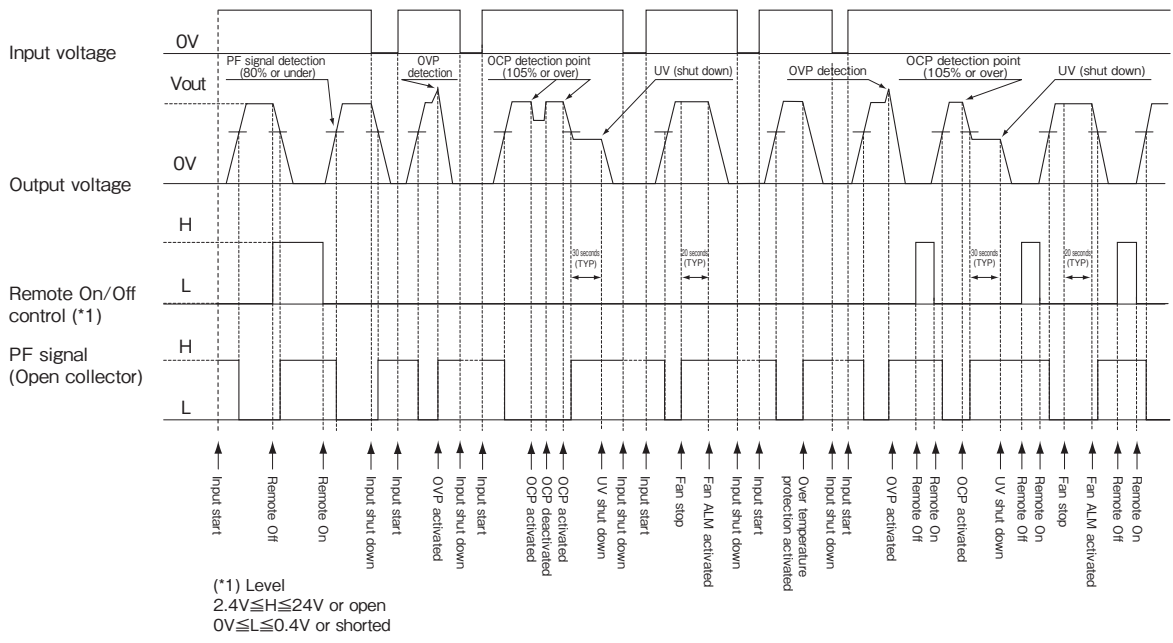

• All specifications are subject to change without notice.

1.Explanation of functions and notes

1 Variable output voltage (RV)

Output voltage can be varied by an external trimmer or external voltage via the RV terminal. When using this function, use twisted wires or shielded wires (-COM should be shielded, recommended length is 2m max.) for wiring from REF/RV/-COM terminals. Be careful about disconnection and mis-wiring.

Model by voltage (V)	RV voltage (V)	Output voltage adjustable range (%)
24	3.5 to 6.5	70 to 130
48	3.5 to 5.75	70 to 115

How to use this function

- Remove the short plate between REF and RV.
- When varying output voltage by using an external trimmer
Turn V.ADJ clockwise until it stops, and connect an external trimmer (5kΩ) to REF, RV, and -COM terminals, as shown in figure (a) below.
- When varying output voltage by external voltage
Connect "+" of the external variable power supply to RV terminal, "-" to -COM terminal.

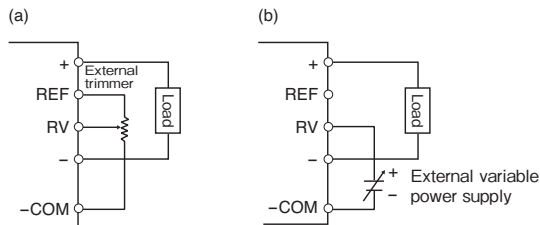

2 Current balance function (CB terminal)

This terminal has the monitoring function. When multiple power supplies are in parallel operation and their CB terminals and -COM terminals are respectively mutually connected, this function controls the output current of the power supplies so that they become equal. Between CB and -COM terminals, voltage approximately proportional to the output current is generated.

(1) Equalization condition

Output voltage fluctuation in each power supply
 $(\text{Maximum voltage} - \text{Minimum voltage}) / \text{Nominal voltage} = 2\% \text{ max.}$

Output current: 20-90% of nominal total output current

(2) Equalization performance (for 2 units)

Output current fluctuation in each power supply under the equalization conditions described above
 $(\text{Maximum current} - \text{Minimum current}) / (\text{Nominal current} \times \text{Number of units in parallel operation}) = 10\% \text{ max.}$

(3) CB terminal connection diagram

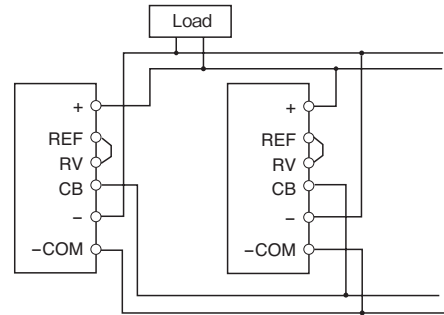

The impedance of load line from each power supply should, if possible, be the same.

Use twisted wires or shielded wires (-COM should be shielded) for wiring from CB and -COM. Parallel operation should be configured with 4 units at maximum.

3 Remote On/Off function

By applying signals described below to the remote On/Off terminals (+RC, -RC), the output voltage can be switched on and off from outside the power supply.

The output voltage is switched off and fans are stopped in the condition of H level (open or 2.4-24V external voltage application: 1.0mA max. inflowing current) between +RC and -RC.

The output voltage is switched on in the condition of L level (shorted or 0-0.4V voltage between terminals: 1.6mA max. outflowing current) between +RC and -RC.

±RC terminals are insulated from the AC input terminal and DC output terminal.

The insulation between the ±RC terminals and the outputs conforms to the common specifications of insulation resistance (between output terminal and case (G)), and the withstand voltage of the AC input terminal and the ±RC terminals also conforms to the common specifications (withstand voltage between input terminal and case (G)).

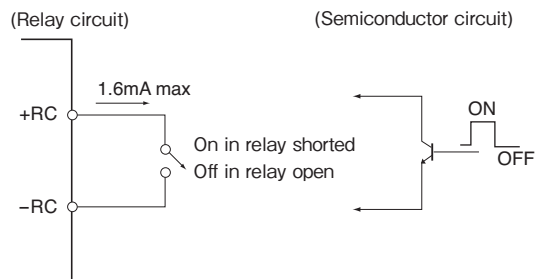

4 Power fail signal

Emits the signal when the output voltage drops to 80% or lower than the set voltage.

Output is shut down and the power fail signal is emitted when power supply protection functions are activated.

Output specifications

Sink current: 50mA max. Voltage between collector and emitter: 40V max. \pm RF terminals are insulated from the AC input terminal and DC output terminal.

The insulation between the \pm RF terminals and the outputs is the same as the insulation resistance between the output and the ground terminal), and the insulation between the AC input terminal and the \pm RF terminals is the same as the insulation resistance between the input terminal and the output terminal.

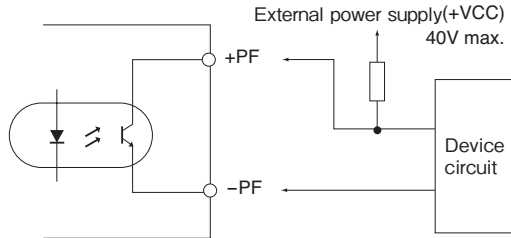

5 Protection functions

Protection functions	Operations
OV Output over voltage protection	When the output voltage rises to level that is too high, this function stops the fans. Operation can be resumed by removing the causes, and then performing the following: Setting the remote on/off terminal to H level once, and again setting it to L level. Or, shutting down input once, and restarting input after 40s or over have passed.
OC Output over current protection	When the over current status continues for over 30s, this function shuts down the output and stops the fans. For cases with this status within 30s, operation resumes automatically. The procedures for manual resumption are the same as in the case of OV above.
FAN Fan stop protection	When the rotation of fans stops, this function shuts down the output. The procedures for resumption are the same as in the case of OV above. Note that resumption is not possible if there is any trouble in the rotation of fans.
TH Over temperature protection	When the temperature inside the power supply unit rises to level that is too high, this function shuts down the output and stops the fans. For resumption, shut down input once, and restart input after 40s or over have passed. Note that resumption is not possible if the temperature inside the power supply unit has not lowered sufficiently.

6 Redundant operation (N+1)

When in redundant operation of power supply, connect a diode to the end of the power supply's output. The impedance of load line from each power supply should, if possible, be the same.

Use twisted wires or shielded wires (-COM should be shielded) for wiring from CB and -COM. The maximum number of the units to be connected is 4 at maximum.

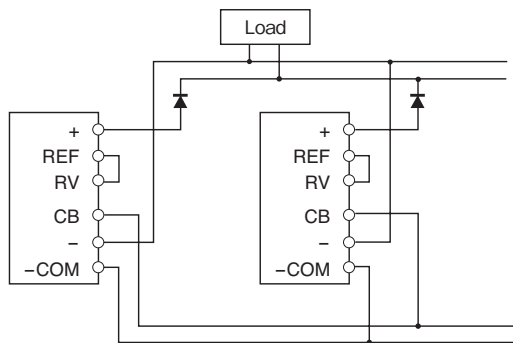

7 Master/slave function

Master/slave operation is applicable by using REF and RV terminals. Connect the REF terminal of the power supply unit to be the master and the RV terminal of the power supply

unit to be the slave, and mutually connect the -COM terminal of each device, as shown in the figure below.

Outputs of all the power supply units can be varied according to V.ADJ of the master power supply unit. The maximum number of the units to be connected is 4.

● In the case of multiple output loads

Use twisted wires or shielded wires (-COM should be shielded) for wiring from RV and -COM.

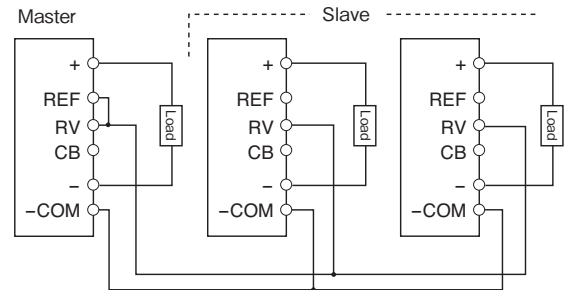

● In the case of one output load

The impedance of load line from each power supply should, if possible, be the same. Use twisted wires or shielded wires (-COM should be shielded) for wiring from RV and -COM.

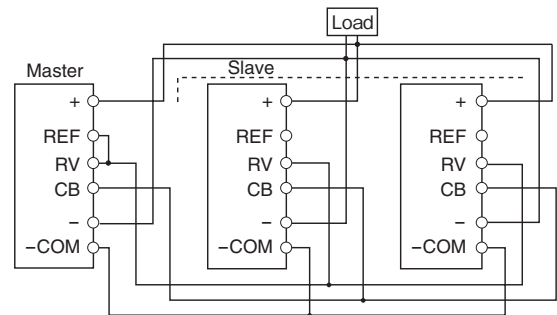

8 Insulation / withstand voltage test

Insulation / withstand voltage test can cause deterioration. Due consideration should be given when implementing a test. It is necessary keep the electric potential equal within inputs, within outputs, and within FGs (frame grounds), respectively. As a testing device, it is the type which starts up gradually when in test on and automatically discharges the charged energy when in test off. If discharging after the test is to be conducted manually, it should be conducted via approximately 100k Ω -1M Ω resistance (Note that discharging via low impedance should be avoided because it can cause deterioration). Due attention should be paid to measures to prevent electric shock in any cases.

● Power supply terminal connections for insulation / withstand voltage test

Short-circuit each terminal of outputs and inputs.

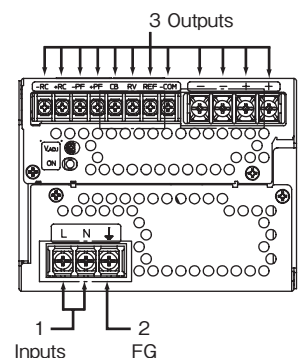

● Connections between testing device and power supply for insulation / withstand voltage test

Make connections between the testing device and power supply unit as shown in the table below. And then conduct a test.

Test conditions	Insulation testing device		Withstand voltage testing device	
	+terminal	-terminal	+terminal	-terminal
Insulation between Input and FG	1	2	—	—
Insulation between Input and Output	1	3	—	—
Insulation between Output and FG	3	2	—	—
Withstand voltage between Input and Output	—	—	1	3
Withstand voltage between Input and FG	—	—	1	2
Withstand voltage between Output and FG	—	—	3	2

2. Mounting

(1) Standard mounting (horizontal)

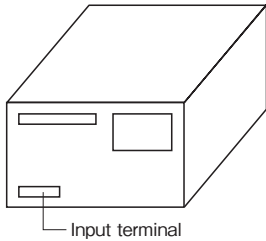

(2) (vertical)

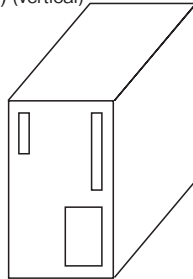

(3) (vertical)

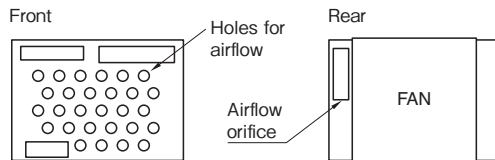
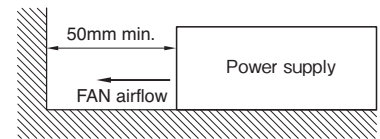
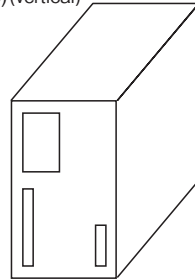

Keep 50mm or more distance between the fan side and adjacent device. Also locate the unit in a position where the thermal exchange between the unit and external air is effective.

Do not block the holes for airflow on the front panel and the airflow orifice on the fan side.

3. Precautions in use

- When using this product, confirm that the power supply's ambient temperature is within the range of operating temperatures. The power supply's ambient temperature means the temperature around the power supply unit, causing a temperature rise inside the device.
- Keep a distance of 10mm or over from adjacent devices, for each side of the unit.
- Select input/output wire materials and noise filters, etc. which have enough allowance in their respective current capacity.
- If the power supply unit is not in use for a long period of time, it is recommended to apply input voltage for approximately 1 hour, every 2 years, to keep the quality of the electrolytic capacitor.
- When the power supply units are used in a series, the nominal current is restricted according to the lowest nominal current value of the units in use. In addition, in order to prevent damage to internal elements and other parts due to reverse voltage applied to the unit, connect a diode (reverse withstand voltage: twice or over the value of total output voltage, forward current: twice or over the value of output current, forward voltage drop: possibly minimum) to prevent reverse voltage, to the output terminal of the unit.
- No materials used in this product do not contain the bromine fire retardant (PBDPEs, PBBs).
- No ODS is not used in production of this product.

4. Troubleshooting

- Is the specified input voltage applied to the input terminal?
- Are the connections of input/output terminals correct?
- Check that the connecting wires are not too thin.
- Check that the output voltage trimmer (V.ADJ) is not turned up too high. If the output voltage trimmer (V.ADJ) is turned up too high, it causes the OVP function to be activated, and the output is shut down.
- Are the logic values of Remote On/Off function and external voltage application set correctly?
- Check that the remote sensing terminal is not open. Applying input voltage in its open status may cause the OVP function to be activated, and the output to be shut down.
- Fan operation in low load
Rotating speed of fans is reduced or fans are stopped when the output power becomes 10W or lower, in order to prolong the fan's life and to improve the power consumption in low load operation. This operation is normal, not a failure.

X-ON Electronics

Largest Supplier of Electrical and Electronic Components

Click to view similar products for [Switching Power Supplies](#) category:

Click to view products by [TDK-Lambda](#) manufacturer:

Other Similar products are found below :

[70841011](#) [73-551-0005](#) [AAD600S-4-OP](#) [R22095](#) [KD0204](#) [9021](#) [S-15F-12](#) [LDIN100150](#) [LPM000-BBAR-01](#) [LPX17S-C](#) [EVS57-10R6/R](#)
[FDC40-24S12](#) [FP80](#) [FRV7000G](#) [22929](#) [CQM1IA121](#) [40370121900](#) [VI-PU22-EXX](#) [40370121910](#) [LDIN5075](#) [432703037161](#) [WRB01X-U](#)
[LPX140-C](#) [08-30466-1040G](#) [09-160CFG](#) [70841004](#) [70841025](#) [VPX3000-CBL-DC](#) [LPM000-BBAR-05](#) [LPM000-BBAR-08](#) [LPM124-](#)
[OUTA1-48](#) [LPM000-BBAR-07](#) [LPM109-OUTA1-10](#) [LPM616-CHAS](#) [08-30466-1055G](#) [08-30466-2175G](#) [DMB-EWG](#) [TVQF-1219-18S](#)
[6504-226-2101](#) [CQM1IPS01](#) [XPFM201A+](#) [MAP80-4000G](#) [LFP300F-24-TY](#) [SMP21-L20-DC24V-5A](#) [VI-MUL-ES](#) [08-30466-0065G](#)
[CME240P-24](#) [VI-RU031-EWWX](#) [08-30466-0028G](#) [S82Y-TS01](#)